

THIS DRAWING IS UNPUBLISHED. RELEASED FOR PUBLICATION
 © COPYRIGHT - By - ALL RIGHTS RESERVED.

LOC	DIST	REVISIONS			
P	LTR	DESCRIPTION	DATE	DWN	APVD
FT	64	AS4	REVISED PER ECO-11-004835	11MAR11	RK HMR

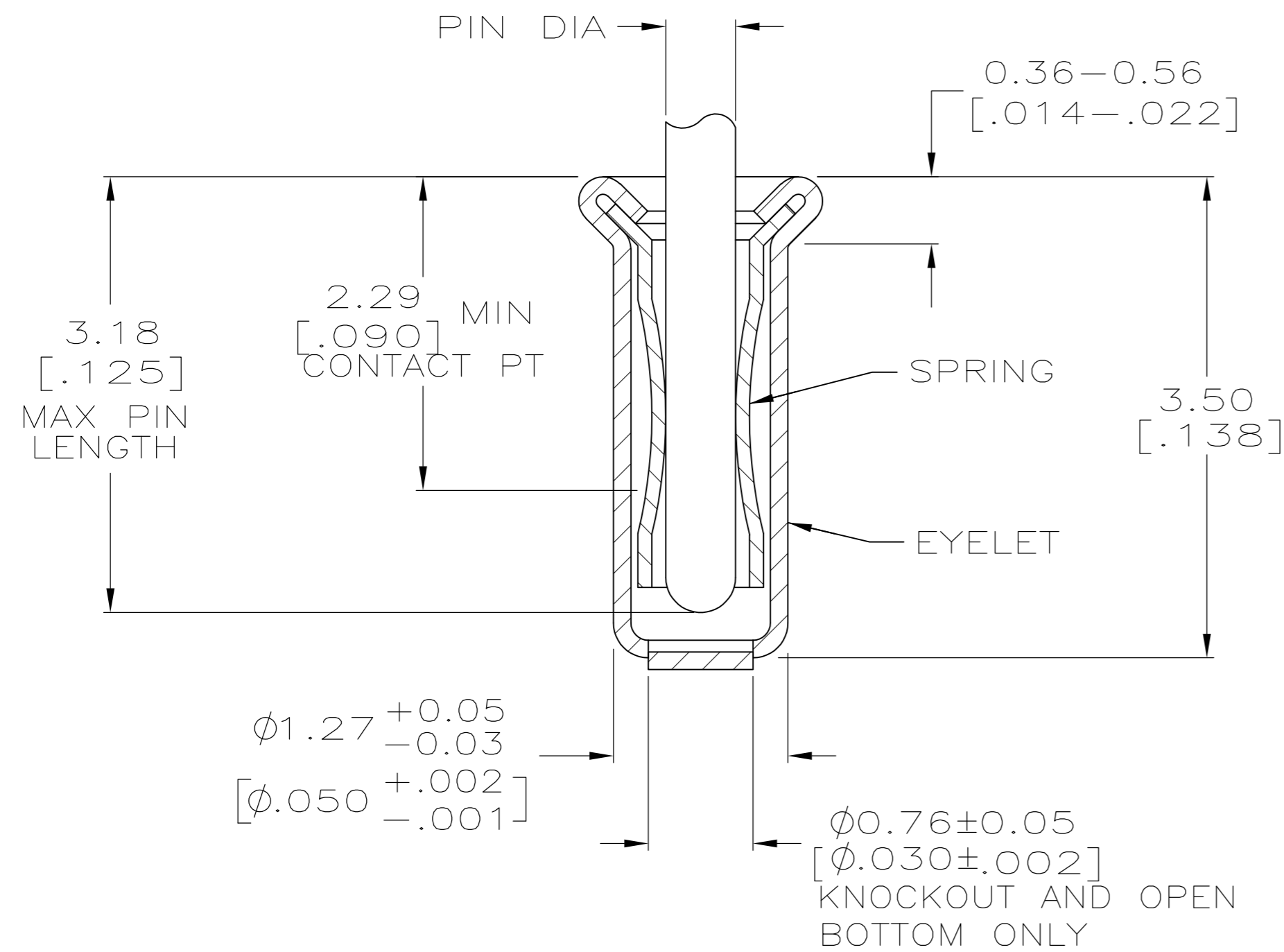
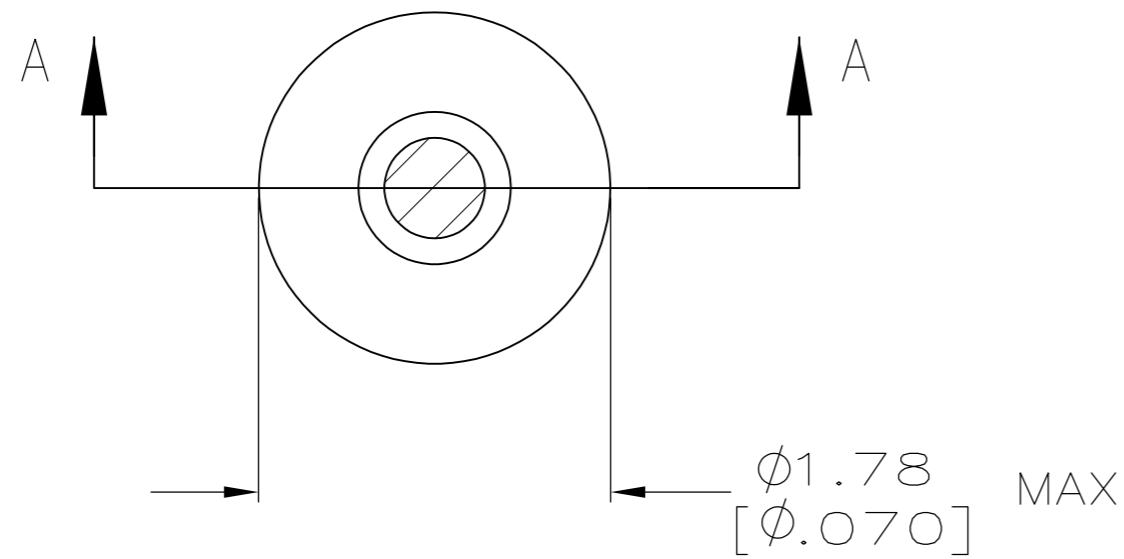

A-A SECTION

- ① TIN PER MIL-T-10727 OR TIN LEAD .000254 [.000100] MIN THK.
- ② GOLD PER MIL-G-45204, TYPE II, 0.00076 [.000030] MIN THK OVER NICKEL PER QQ-N-290 0.00028 [.000011] MIN THK ON CONTACT AREA.
- ③ GOLD FLASH PER MIL-G-45204, TYPE II, 0.13 μ m [.000005] MIN THK. OVER NICKEL PLATE PER QQ-N-290 0.51 μ m-1.52 μ m [.000020-.000060] EXT THK.
- 4. RECOMMENDED HOLE SIZE, PLATED OR UNPLATED:
 MACHINE INSERTION: 1.32 \pm 0.05 [.052 \pm 0.002]
 HAND INSERTION: 1.32 $+0.10$
 -0.00 [.052 $+0.004$
 -0.000]
- 5. APPLICATION TOOL PART NUMBER:
 MACHINE NO. 682127-3
 INSERTION HEAD NO. 682039-2
- ⑥ TO INSURE PROPER SPRING TENSION DO NOT EXCEED A 0.05 [.002] DIFFERENCE IN PIN DIA WHEN CHANGING TO A SMALLER PIN.
- 7. BOTTOM PLUG KNOCKOUT TOOL PART NUMBER 69729 WITH TIP PART NUMBER 69728.
- ⑧ MATERIAL: SPRING: BERYLLIUM COPPER QQ-C-533
 EYELET: COPPER: QQ-C-576
- ⑨ OBSOLETE PARTS: OBSOLETE CIS STREAMLINING PER D.RENAUD/D.SINISI

SUPSD BY	2-331272-7				331272-2
OBSOLETE			TIN ①	GOLD ②	4-331272-3
OBSOLETE		0.56-0.64 [.022-.025]	GOLD ③		4-331272-2
OBSOLETE	OPEN		TIN ①	TIN ①	4-331272-1
OBSOLETE		0.46-0.53 [.018-.021]	GOLD ③	GOLD ②	3-331272-9
OBSOLETE			TIN ①	TIN ①	3-331272-8
OBSOLETE		0.56-0.64 [.022-.025]	GOLD ③	GOLD ②	3-331272-7
⑨ OBSOLETE	KNOCKOUT		TIN ①	TIN ①	3-331272-5
OBSOLETE		0.46-0.53 [.018-.021]	GOLD ③		3-331272-4
OBSOLETE			TIN ①	TIN ①	3-331272-3
OBSOLETE		0.56-0.64 [.022-.025]	GOLD ③	GOLD ②	3-331272-1
OBSOLETE			TIN ①		3-331272-0
OBSOLETE		0.46-0.53 [.018-.021]	GOLD ③		2-331272-7
OBSOLETE			TIN ①	TIN ①	2-331272-6
OBSOLETE	CLOSED		GOLD ③		2-331272-5
SUPERSEDED		0.56-0.64 [.022-.025]	TIN ①	TIN ①	2-331272-3
OBSOLETE		0.46-0.53 [.018-.021]	GOLD ③	GOLD ②	2-331272-2
OBSOLETE			TIN ①	TIN ①	2-331272-1
	BOTTOM TYPE	RECOMMENDED PIN DIA ⑥	EYELET	SPRING	PART NO
			FINISH		

THIS DRAWING IS A CONTROLLED DOCUMENT. DWN R. TALLEY 4-5-91
 CHK -
 APVD -
 PRODUCT SPEC -
 APPLICATION SPEC -
 WEIGHT -
 CUSTOMER DRAWING

TE TE Connectivity

MINIATURE SPRING SOCKET ASSEMBLY, SERIES 2

SIZE A2 CAGE CODE 00779 DRAWING NO C-331272 RESTRICTED TO -
 SCALE 20:1 SHEET 1 OF 1 REV AS4