

THIS DOCUMENT IS SUBJECT TO CHANGE WITHOUT NOTICE. IT IS CONFIDENTIAL AND A PROPERTY OF AMPHENOL LTW. DISCLOSURE TO THIRD PARTY HAS TO BE AUTHORIZED BY AMPHENOL LTW.

REV.	ECN NO.	DATE	SIGN	DESCRIPTION
A		2021/10/09	Xiaofeng	New Initial
B	C220320	2022/03/02	Xiaofeng	△ X60

(L Dimensions refer to table)

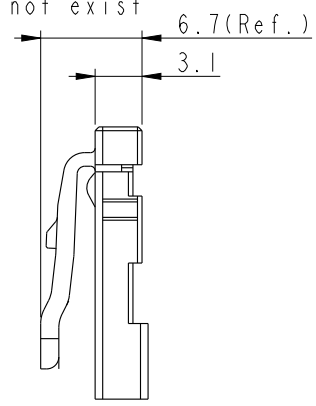
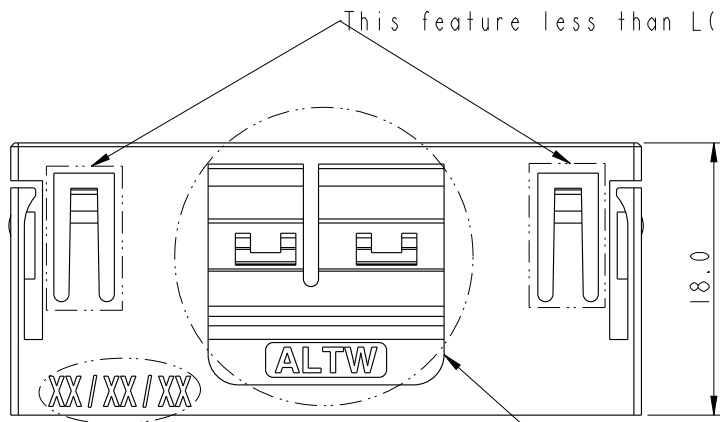
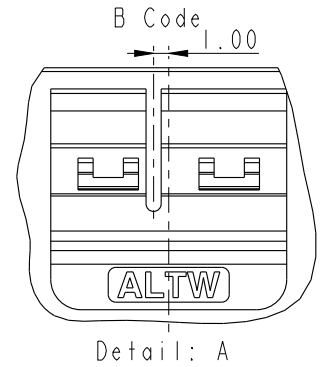
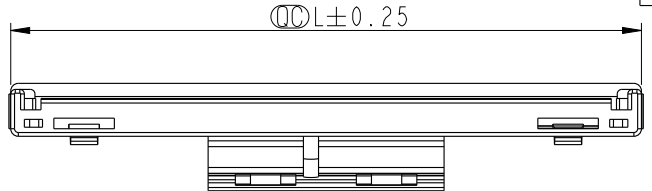

Laser Etching
Corresponding Pin Number

ZB- XX NMAN-BN0001

- XX: Number Of Contacts (Pitch)
- AA: 40(P0.9)/20(P1.8)
- AB: 38(P0.9)/19(P1.8)
- AC: 36(P0.9)/18(P1.8)/12(P2.7)
- AD: 34(P0.9)/17(P1.8)
- AE: 32(P0.9)/16(P1.8)
- AF: 30(P0.9)/15(P1.8)/10(P2.7)
- AG: 28(P0.9)/14(P1.8)
- AH: 26(P0.9)/13(P1.8)
- AI: 24(P0.9)/12(P1.8)/8(P2.7)
- AJ: 22(P0.9)/11(P1.8)

- Note:
- * Ⓞ Important Dimensions To Check.
 - * Material: Thermoplastic, Black.
 - * FFC
 - Recommended Pitch: 1.0mm, 1.5mm, 2.0mm.
 - * WTB
 - Recommended Applicable Wire gauge
22AWG ~ 26AWG
 - * All Parts Are RoHS Compliant.

UNIT: mm	Ⓞ	Ⓞ
TOLERANCE		
.X	±0.25	
.XX	±0.1	
.XXX	±0.05	
ANGLES	±1°	

TITLE Z CONN., N SHLD, B, NONE, M		
SCALE 1:1	SIZE A4	SHEET 1 OF 11
REV. B	WC-REV. .0	Ⓞ : Inspection item

Amphenol LTW
安費諾亮泰企業股份有限公司

ITEM NO.	DRAWN BY Xiaofeng	DATE 2021/10/09
DWG NO. ZB-XXNMAN-BN0001	CHECKED BY Feng-Li	DATE 2021/10/09
CUSTOMER ALTW	APPROVED BY Jerry	DATE 2021/10/09

Flexible Printed Circuit
Pitch 0.9mm

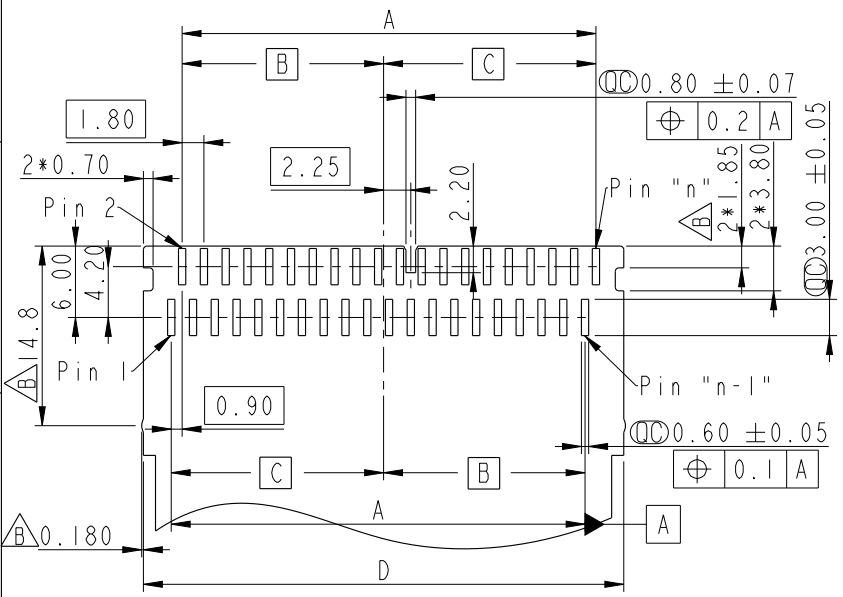

RECOMMENDED FPC LAYOUT

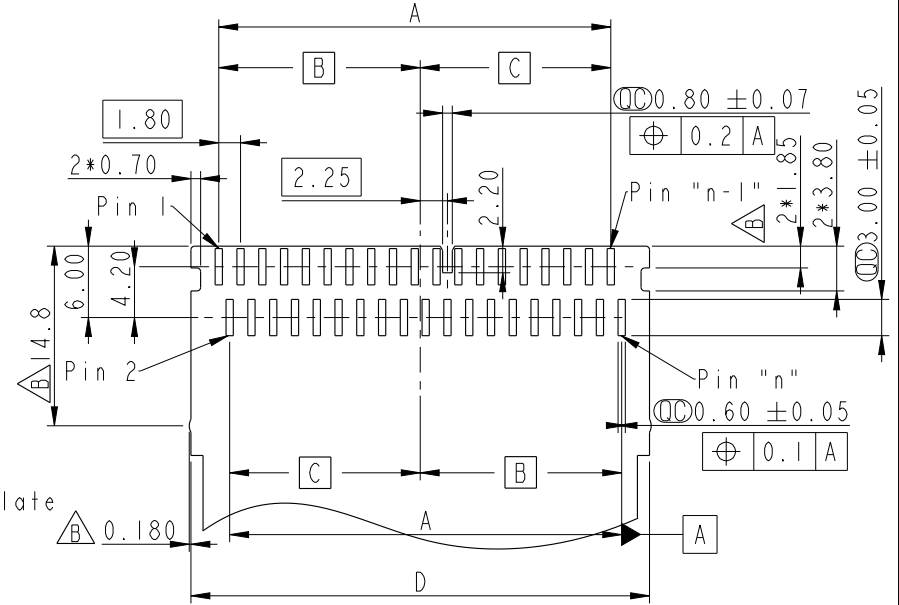

RECOMMENDED FPC LAYOUT

PIN	L (mm)	A (mm)	B (mm)	C (mm)	D (mm)
24	27.3	19.8	9.45	10.35	25.3
28	30.9	23.4	11.25	12.15	28.9
32	34.5	27.0	13.05	13.95	32.5
36	38.1	30.6	14.85	15.75	36.1
40	41.7	34.2	16.65	17.55	39.7

PIN	L (mm)	A (mm)	B (mm)	C (mm)	D (mm)
22	25.5	18.0	9.45	8.55	23.5
26	29.1	21.6	11.25	10.35	27.1
30	32.7	25.2	13.05	12.15	30.7
34	36.3	28.8	14.85	13.95	34.3
38	39.9	32.4	16.65	15.75	37.9

UNIT: mm

TOLERANCE
.X ±0.25
.XX ±0.1
.XXX ±0.05
ANGLES ±1°

TITLE
Z CONN., N SHLD, B, NONE, M

SCALE 1:1 SIZE A4 SHEET 2 OF 11

REV. B WC-REV. .0

QC: Inspection item

Amphenol LTW
安費諾亮泰企業股份有限公司

ITEM NO. ZB-XXNMAN-BN0001

DRAWN BY Xiaofeng DATE 2021/10/09

CHECKED BY Feng-Li DATE 2021/10/09

APPROVED BY Jerry DATE 2021/10/09

CUSTOMER ALTW

Flexible Printed Circuit
Pitch 1.8mm

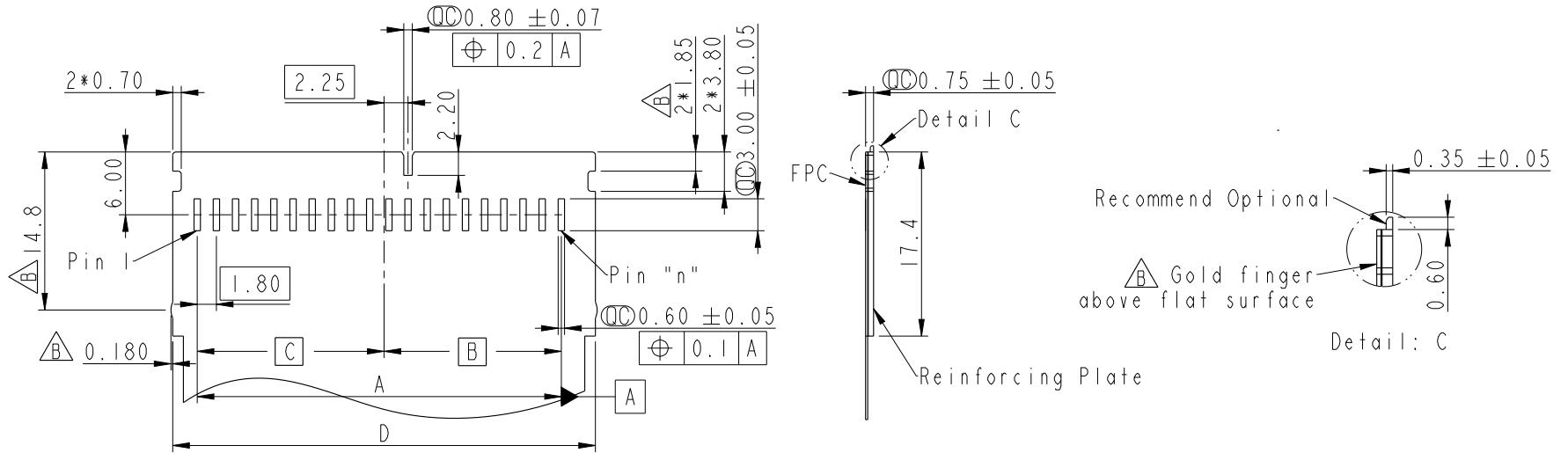

RECOMMENDED FPC LAYOUT

PIN	L (mm)	A (mm)	B (mm)	C (mm)	D (mm)
11	25.5	18.0	9.45	8.55	23.5
12	27.3	19.8	9.45	10.35	25.3
13	29.1	21.6	11.25	10.35	27.1
14	30.9	23.4	11.25	12.15	28.9
15	32.7	25.2	13.05	12.15	30.7
16	34.5	27.0	13.05	13.95	32.5
17	36.3	28.8	14.85	13.95	34.3
18	38.1	30.6	14.85	15.75	36.1
19	39.9	32.4	16.65	15.75	37.9
20	41.7	34.2	16.65	17.55	39.7

UNIT: mm



TITLE Z CONN., N SHLD, B, NONE, M			
SCALE 1:1	SIZE A4	SHEET 3 OF 11	
REV. B	WC-REV. .0	Ⓞ: Inspection item	

Amphenol LTW
安費諾亮泰企業股份有限公司

ITEM NO	DRAWN BY Xiaofeng	DATE 2021/10/09
DWG NO ZB-XXNMAN-BN0001	CHECKED BY Feng-Li	DATE 2021/10/09
CUSTOMER ALTW	APPROVED BY Jerry	DATE 2021/10/09

THIS DOCUMENT IS SUBJECT TO CHANGE WITHOUT NOTICE. IT IS CONFIDENTIAL AND A PROPERTY OF AMPHENOL LTW. DISCLOSURE TO THIRD PARTY HAS TO BE AUTHORIZED BY AMPHENOL LTW.

THIS DOCUMENT IS SUBJECT TO CHANGE WITHOUT NOTICE. IT IS CONFIDENTIAL AND A PROPERTY OF AMPHENOL LTW. DISCLOSURE TO THIRD PARTY HAS TO BE AUTHORIZED BY AMPHENOL LTW.

Flexible Printed Circuit
Pitch 2.7mm

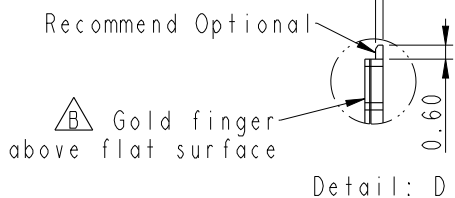
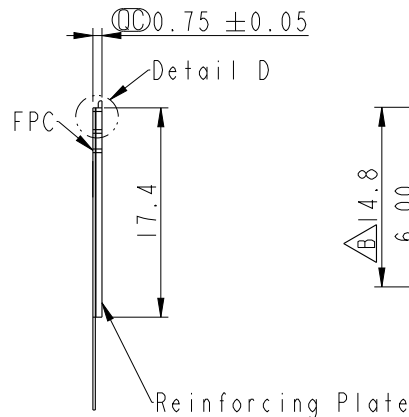
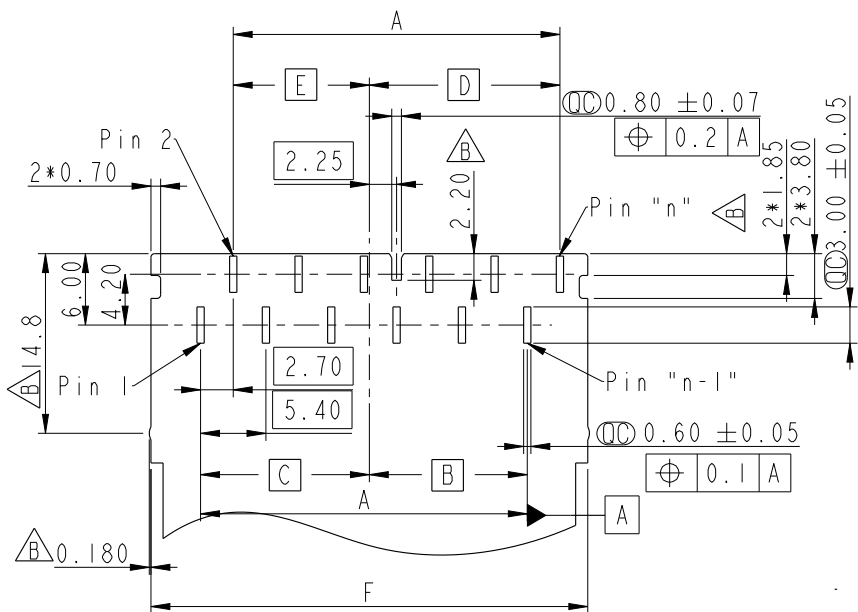

RECOMMENDED FPC LAYOUT

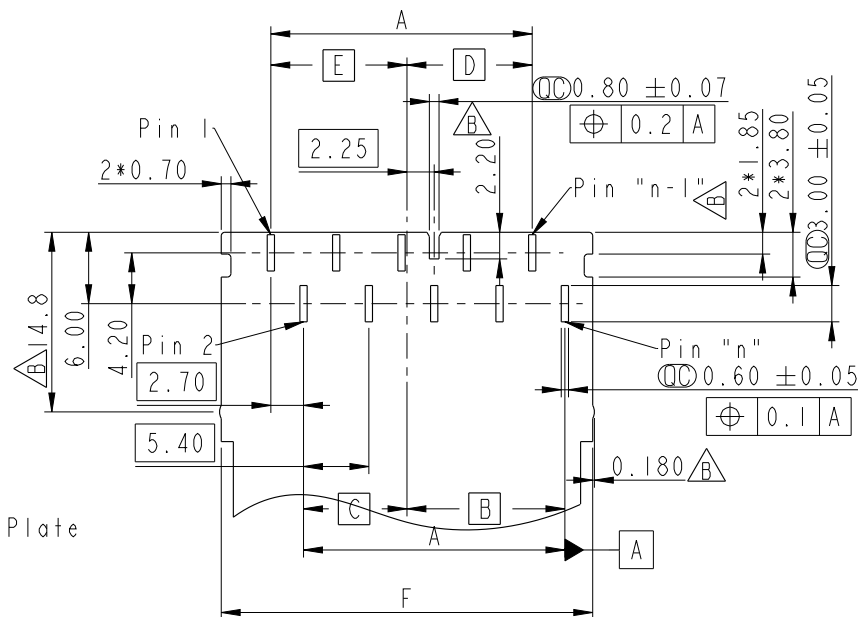

RECOMMENDED FPC LAYOUT

PIN	L (mm)	F (mm)	A (mm)	B (mm)	C (mm)	D (mm)	E (mm)
8	27.3	25.3	16.2	7.65	8.55	10.35	5.85
12	38.1	36.1	27.0	13.05	13.95	15.75	11.25

PIN	L (mm)	F (mm)	A (mm)	B (mm)	C (mm)	D (mm)	E (mm)
10	32.7	30.7	21.6	13.05	8.55	10.35	11.25

UNIT: mm			TITLE Z CONN., N SHLD, B, NONE, M				
TOLERANCE	.X ±0.25	.XX ±0.1	SCALE 1:1	SIZE A4	SHEET 4	OF 11	
ANGLES	.XXX ±0.05	±1°	REV. B	WC-REV. .0	QC: Inspection item		

Amphenol LTW
安費諾亮泰企業股份有限公司

ITEM NO	DRAWN BY Xiaofeng	DATE 2021/10/09
DWG NO ZB-XXNMAN-BN0001	CHECKED BY Feng-Li	DATE 2021/10/09
CUSTOMER ALTW	APPROVED BY Jerry	DATE 2021/10/09

Flexible Flat Cables
Pitch 0.9mm

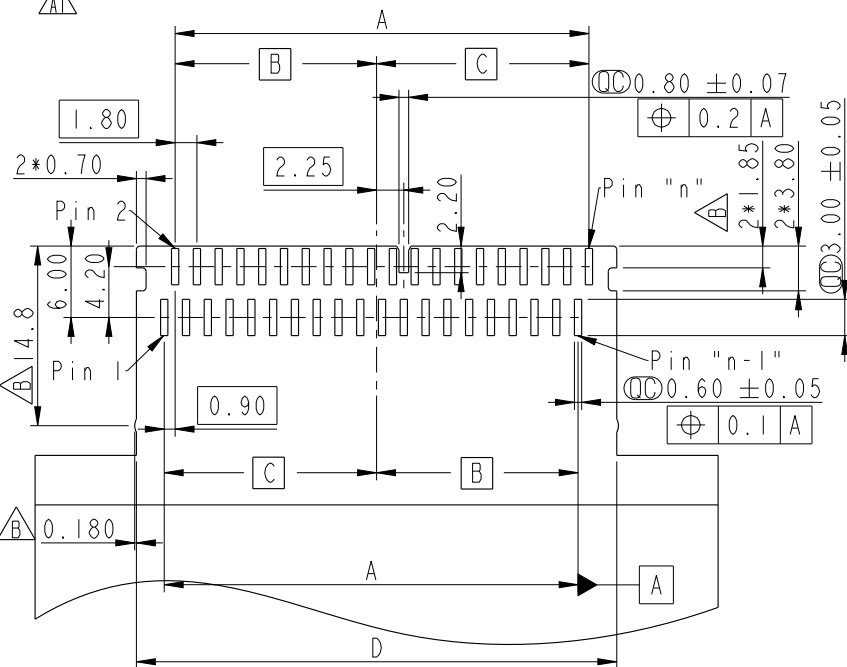

RECOMMENDED FFC LAYOUT

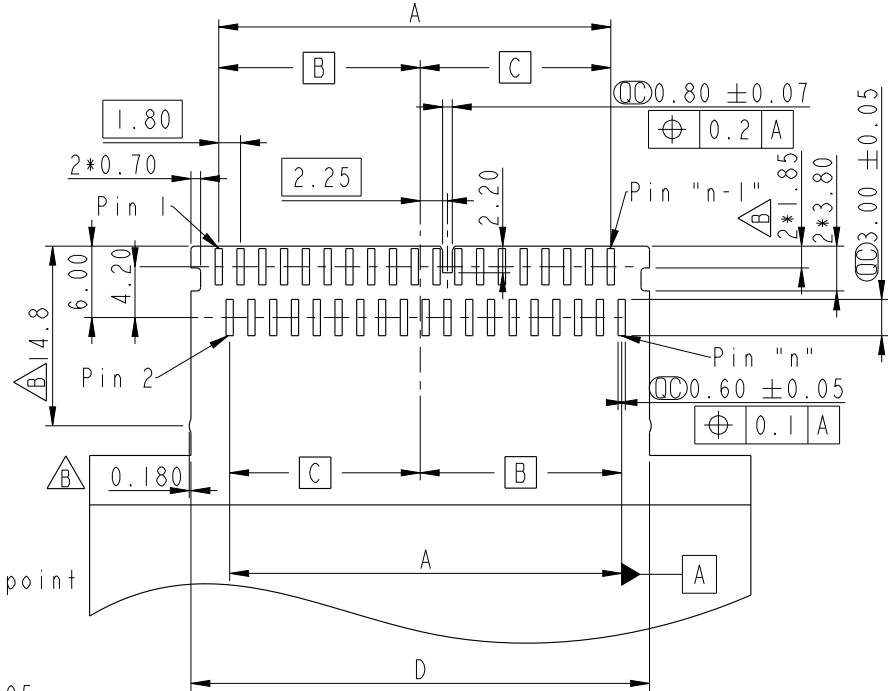

RECOMMENDED FFC LAYOUT

Recommend Optional

Gold finger
above flat surface

Detail: E

PIN	L (mm)	A (mm)	B (mm)	C (mm)	D (mm)
24	27.3	19.8	9.45	10.35	25.3
28	30.9	23.4	11.25	12.15	28.9
32	34.5	27.0	13.05	13.95	32.5
36	38.1	30.6	14.85	15.75	36.1
40	41.7	34.2	16.65	17.55	39.7

PIN	L (mm)	A (mm)	B (mm)	C (mm)	D (mm)
22	25.5	18.0	9.45	8.55	23.5
26	29.1	21.6	11.25	10.35	27.1
30	32.7	25.2	13.05	12.15	30.7
34	36.3	28.8	14.85	13.95	34.3
38	39.9	32.4	16.65	15.75	37.9

UNIT: mm

TOLERANCE
.X ±0.25
.XX ±0.1
.XXX ±0.05
ANGLES ±1°

TITLE
Z CONN., N SHLD, B, NONE, M

SCALE 1:1 SIZE A4 SHEET 5 OF 11

REV. B WC-REV. .0 Inspection item

Amphenol LTW
安費諾亮泰企業股份有限公司

ITEM NO. DWG NO. ZB-XXNMAN-BN0001 CUSTOMER ALTW

DRAWN BY Xiaofeng
CHECKED BY Feng-Li
APPROVED BY Jerry

DATE 2021/10/09
DATE 2021/10/09
DATE 2021/10/09

THIS DOCUMENT IS SUBJECT TO CHANGE WITHOUT NOTICE. IT IS CONFIDENTIAL AND A PROPERTY OF AMPHENOL LTW. DISCLOSURE TO THIRD PARTY HAS TO BE AUTHORIZED BY AMPHENOL LTW.

Flexible Flat Cables
Pitch 1.8mm

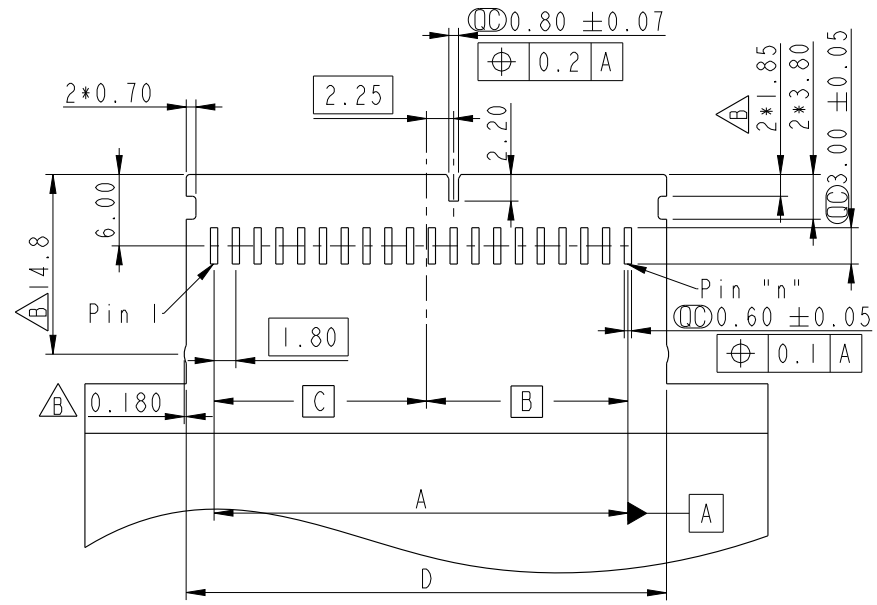

RECOMMENDED FFC LAYOUT

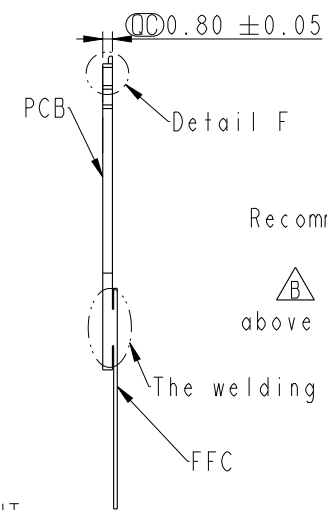

Recommend Optional
 Gold finger above flat surface

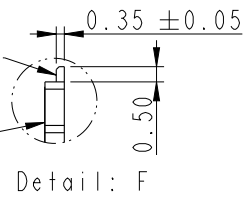

The welding point

FFC

PIN	L (mm)	A (mm)	B (mm)	C (mm)	D (mm)
11	25.5	18.0	9.45	8.55	23.5
12	27.3	19.8	9.45	10.35	25.3
13	29.1	21.6	11.25	10.35	27.1
14	30.9	23.4	11.25	12.15	28.9
15	32.7	25.2	13.05	12.15	30.7
16	34.5	27.0	13.05	13.95	32.5
17	36.3	28.8	14.85	13.95	34.3
18	38.1	30.6	14.85	15.75	36.1
19	39.9	32.4	16.65	15.75	37.9
20	41.7	34.2	16.65	17.55	39.7

UNIT: mm

TOLERANCE
 .X ±0.25
 .XX ±0.1
 .XXX ±0.05
 ANGLES ±1°

TITLE
Z CONN., N SHLD, B, NONE, M

SCALE 1:1 SIZE A4 SHEET 6 OF 11

REV. B WC-REV. .0

QC: Inspection item

Amphenol LTW
 安費諾亮泰企業股份有限公司

ITEM NO

DWG NO
ZA-XXNMAN-BN0001

CUSTOMER
ALTW

DRAWN BY
Xiaofeng

CHECKED BY
Feng-Li

APPROVED BY
Jerry

DATE
2021/10/09

DATE
2021/10/09

DATE
2021/10/09

THIS DOCUMENT IS SUBJECT TO CHANGE WITHOUT NOTICE. IT IS CONFIDENTIAL AND A PROPERTY OF Amphenol LTW. DISCLOSURE TO THIRD PARTY HAS TO BE AUTHORIZED BY Amphenol LTW.

Flexible Flat Cables
Pitch 2.7mm

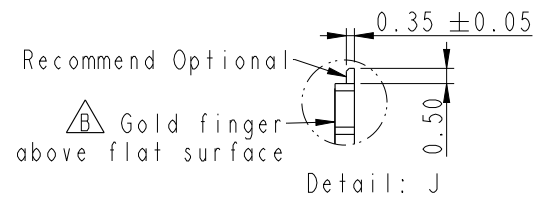
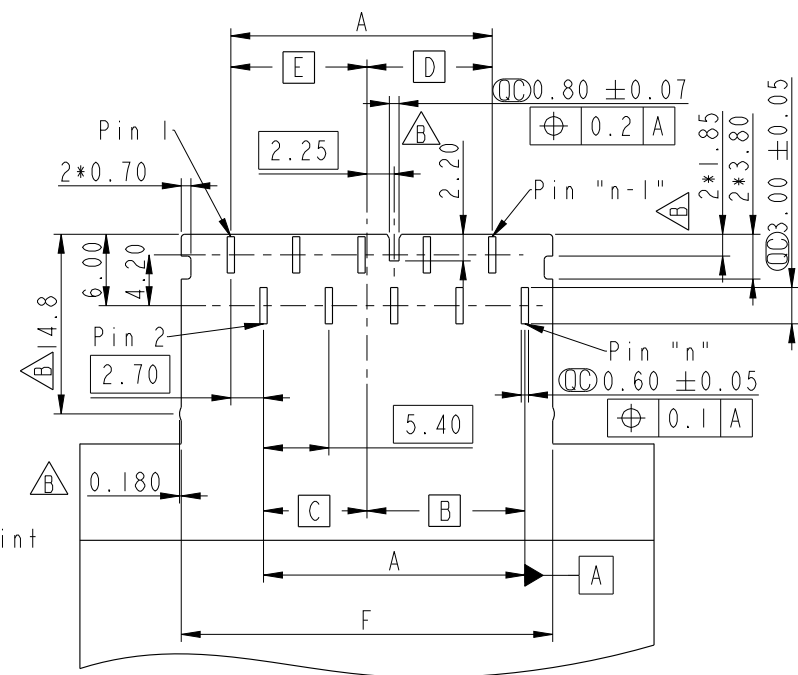
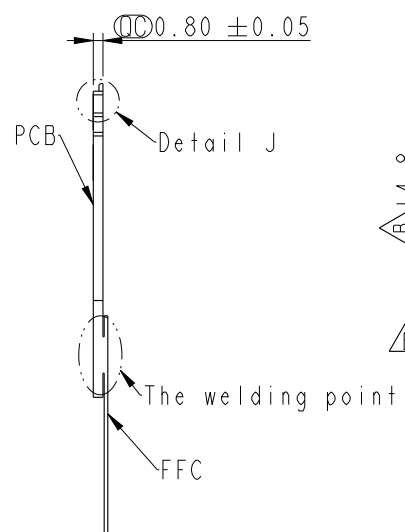
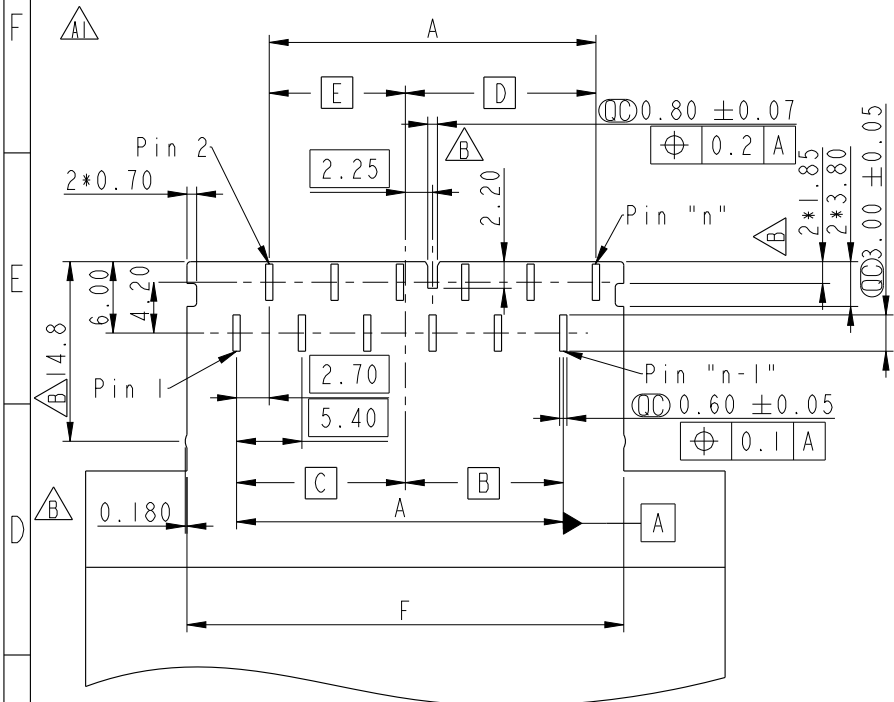

RECOMMENDED FFC LAYOUT

RECOMMENDED FFC LAYOUT

PIN	L (mm)	F (mm)	A (mm)	B (mm)	C (mm)	D (mm)	E (mm)
8	27.3	25.3	16.2	7.65	8.55	10.35	5.85
12	38.1	36.1	27.0	13.05	13.95	15.75	11.25

PIN	L (mm)	F (mm)	A (mm)	B (mm)	C (mm)	D (mm)	E (mm)
10	32.7	30.7	21.6	13.05	8.55	10.35	11.25

UNIT: mm		TITLE Z CONN., N SHLD, B, NONE, M
TOLERANCE .X ±0.25 .XX ±0.1 .XXX ±0.05 ANGLES ±1°	SCALE 1:1	SIZE A4
	REV. B	SHEET 7 OF 11
	WC-REV. .0	QC: Inspection item

Amphenol LTW
安費諾亮泰企業股份有限公司

ITEM NO	DRAWN BY Xiaofeng	DATE 2021/10/09
DWG NO ZA-XXNMAN-BN0001	CHECKED BY Feng-Li	DATE 2021/10/09
CUSTOMER ALTW	APPROVED BY Jerry	DATE 2021/10/09

Wire to Board
Pitch 0.9mm

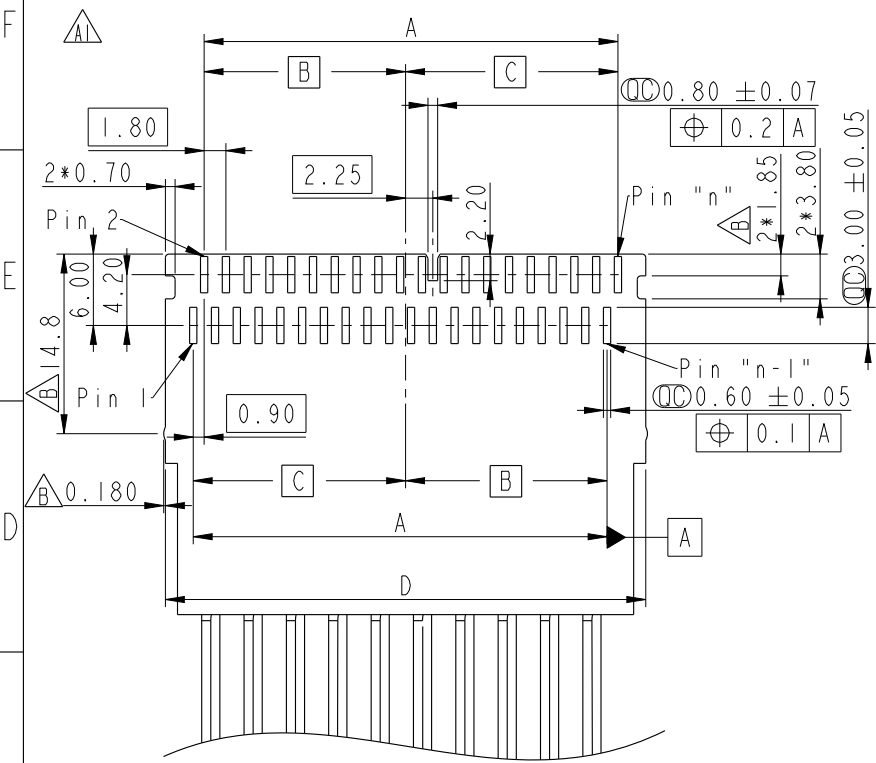

RECOMMENDED WTB LAYOUT

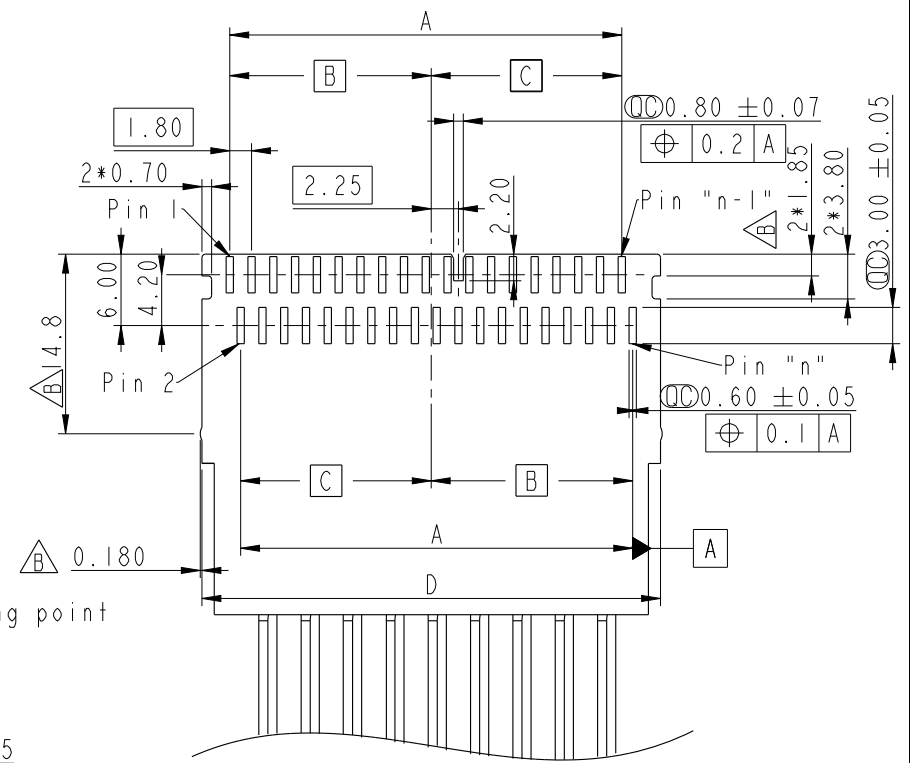

RECOMMENDED WTB LAYOUT

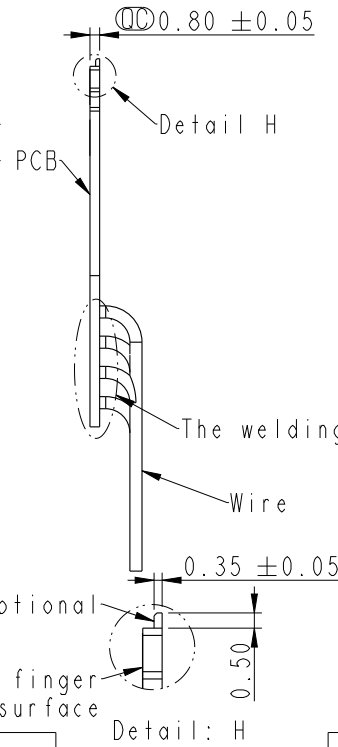

Recommend Optional
Gold finger
above flat surface

PIN	L (mm)	A (mm)	B (mm)	C (mm)	D (mm)
24	27.3	19.8	9.45	10.35	25.3
28	30.9	23.4	11.25	12.15	28.9
32	34.5	27.0	13.05	13.95	32.5
36	38.1	30.6	14.85	15.75	36.1
40	41.7	34.2	16.65	17.55	39.7

PIN	L (mm)	A (mm)	B (mm)	C (mm)	D (mm)
22	25.5	18.0	9.45	8.55	23.5
26	29.1	21.6	11.25	10.35	27.1
30	32.7	25.2	13.05	12.15	30.7
34	36.3	28.8	14.85	13.95	34.3
38	39.9	32.4	16.65	15.75	37.9

UNIT: mm

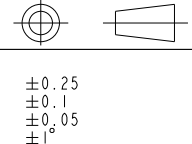

TITLE
Z CONN., N SHLD, B, NONE, M

SCALE 1:1 SIZE A4 SHEET 8 OF 11

REV. B WC-REV. .0

QC: Inspection item

Amphenol LTW
安費諾亮泰企業股份有限公司

ITEM NO	DRAWN BY	DATE
DWG NO	Checked By	DATE
CUSTOMER	APPROVED BY	DATE

ALTW

THIS DOCUMENT IS SUBJECT TO CHANGE WITHOUT NOTICE. IT IS CONFIDENTIAL AND A PROPERTY OF AMPHENOL LTW. DISCLOSURE TO THIRD PARTY HAS TO BE AUTHORIZED BY AMPHENOL LTW.

Wire to Board
Pitch 1.8mm

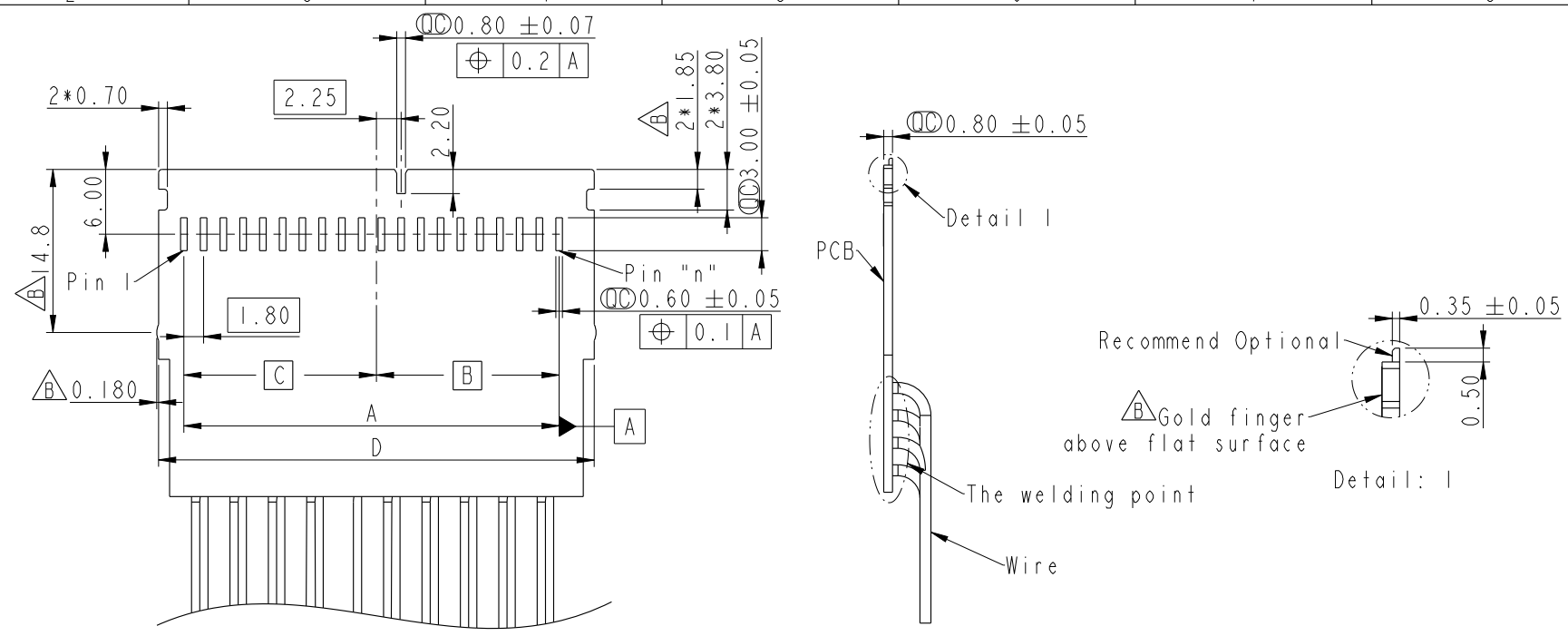

RECOMMENDED WTB LAYOUT

PIN	L (mm)	A (mm)	B (mm)	C (mm)	D (mm)
11	25.5	18.0	9.45	8.55	23.5
12	27.3	19.8	9.45	10.35	25.3
13	29.1	21.6	11.25	10.35	27.1
14	30.9	23.4	11.25	12.15	28.9
15	32.7	25.2	13.05	12.15	30.7
16	34.5	27.0	13.05	13.95	32.5
17	36.3	28.8	14.85	13.95	34.3
18	38.1	30.6	14.85	15.75	36.1
19	39.9	32.4	16.65	15.75	37.9
20	41.7	34.2	16.65	17.55	39.7

UNIT: mm 	Z CONN., N SHLD, B, NONE, M			Amphenol LTW		ITEM NO	DRAWN BY	DATE
	SCALE 1:1 SIZE A4 SHEET 9 OF 11			安費諾亮泰企業股份有限公司		DWG NO	CHECKED BY	DATE
	REV. B WC-REV. .0 ☉: Inspection item					CUSTOMER	APPROVED BY	DATE
					ALTW	Jerry	Xiaofeng	2021/10/09

THIS DOCUMENT IS SUBJECT TO CHANGE WITHOUT NOTICE. IT IS CONFIDENTIAL AND A PROPERTY OF Amphenol LTW. DISCLOSURE TO THIRD PARTY HAS TO BE AUTHORIZED BY Amphenol LTW.

Wire to Board
Pitch 2.7mm

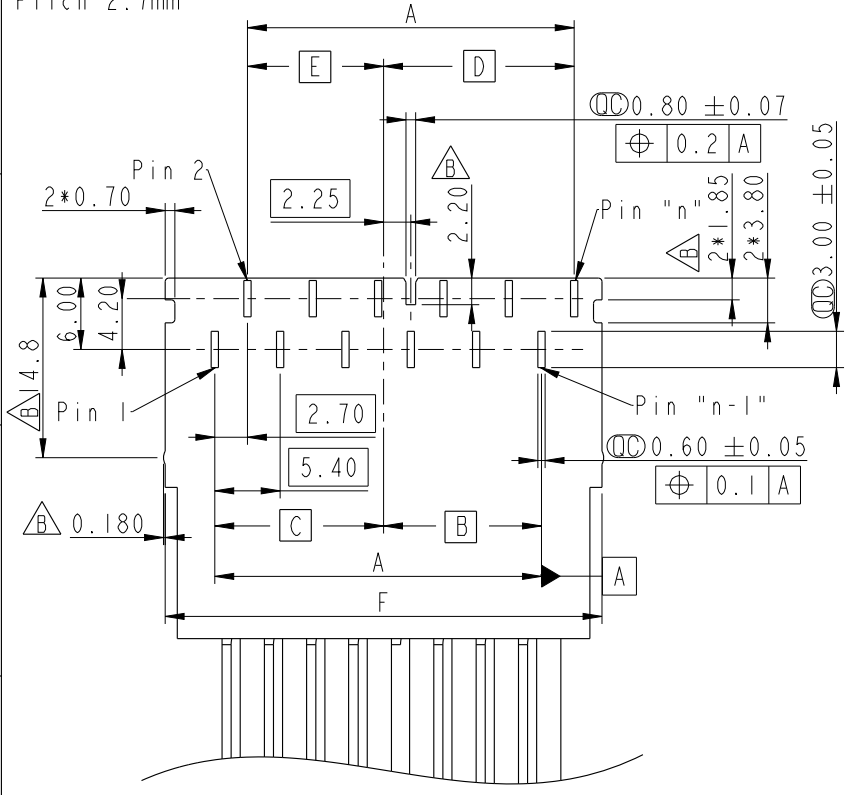

RECOMMENDED WTB LAYOUT

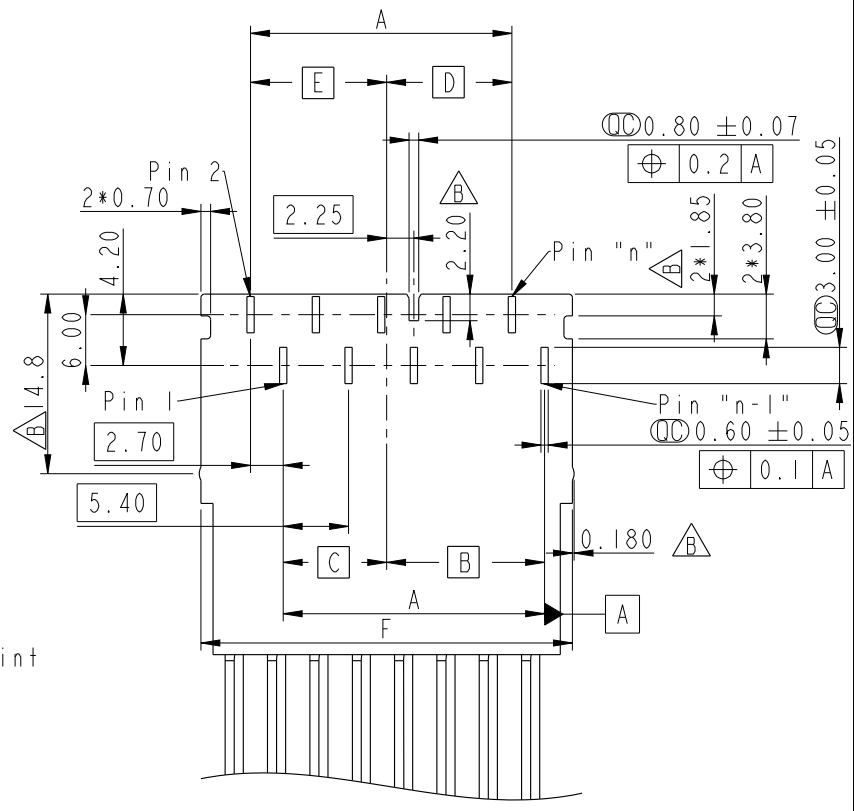
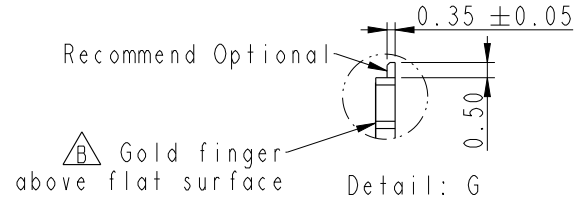
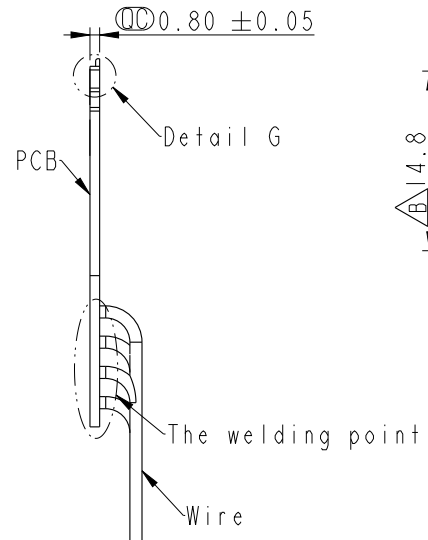

RECOMMENDED WTB LAYOUT

PIN	L (mm)	F (mm)	A (mm)	B (mm)	C (mm)	D (mm)	E (mm)
8	27.3	25.3	16.2	7.65	8.55	10.35	5.85
12	38.1	36.1	27.0	13.05	13.95	15.75	11.25

PIN	L (mm)	F (mm)	A (mm)	B (mm)	C (mm)	D (mm)	E (mm)
10	32.7	30.7	21.6	13.05	8.55	10.35	11.25

UNIT: mm		TITLE Z CONN., N SHLD, B, NONE, M
TOLERANCE .X ±0.25 .XX ±0.1 .XXX ±0.05 ANGLES ±1°	SCALE 1:1	SIZE A4
	REV. B	SHEET 10 OF 11
	WC-REV. .0	QC: Inspection item

Amphenol LTW
安費諾亮泰企業股份有限公司

ITEM NO	DRAWN BY Xiaofeng	DATE 2021/10/09
DWG NO ZA-XXNMAN-BN0001	CHECKED BY Feng Li	DATE 2021/10/09
CUSTOMER ALTW	APPROVED BY Jerry	DATE 2021/10/09

THIS DOCUMENT IS SUBJECT TO CHANGE WITHOUT NOTICE. IT IS CONFIDENTIAL AND A PROPERTY OF Amphenol LTW. DISCLOSURE TO THIRD PARTY HAS TO BE AUTHORIZED BY Amphenol LTW.

Packing:

Vacuum-Cover Lower Cover

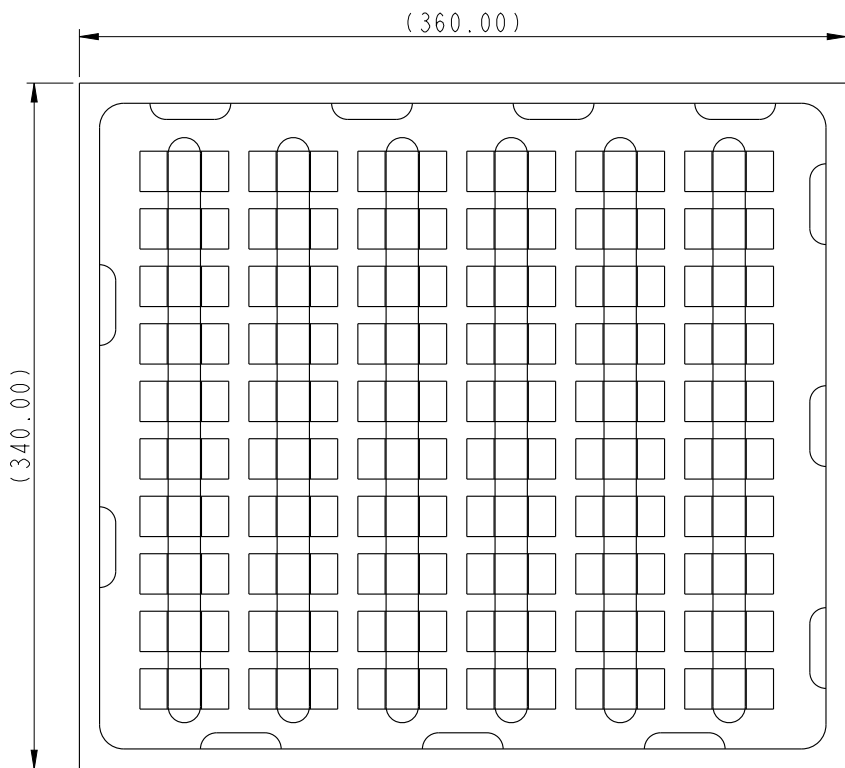

60 PCS/Tray

20 Tray/BOX

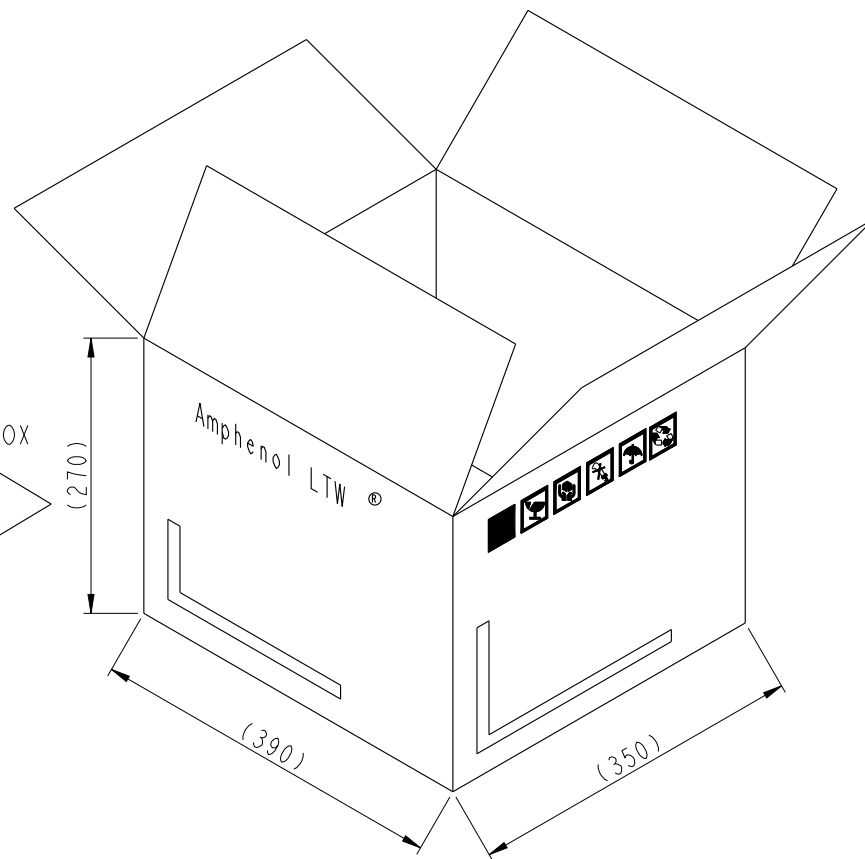
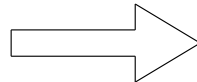

Note:

- * Important Dimensions To Check.
- * Material: PET, 0.6mm, CR

UNIT: mm

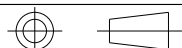

TITLE Z CONN., N SHLD, B, NONE, M			
SCALE 1:1	SIZE A4	SHEET 11 OF 11	
REV. B	WC-REV. .0	QC: Inspection item	

Amphenol LTW
安費諾亮泰企業股份有限公司

ITEM NO	DRAWN BY Xiaofeng	DATE 2021/10/09
DWG NO ZB-XXNMAN-BN0001	CHECKED BY Feng Li	DATE 2021/10/09
CUSTOMER ALTW	APPROVED BY Jerry	DATE 2021/10/09