

This document is the property of and embodies CONFIDENTIAL and PROPRIETARY information of AOR. No part of the information shown on this document may be used in any way or disclosed to others without the written consent of AOR. © 2019 AOR

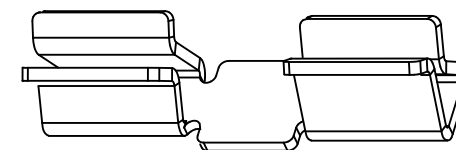

REV.	ECR/ECN No.	DESCRIPTION	DRAWN/DATE	CHECKED/DATE	APPROVED/DATE
C		Increase key dimensions	DeMing Li 2015-12-18	Qi Han 2015-12-18	Hongkui Liu 2015-12-18
D	ECN2022152	UPDATE FRAME	Abner 2022-09-27	Staven 2022-09-27	Sam 2022-09-27

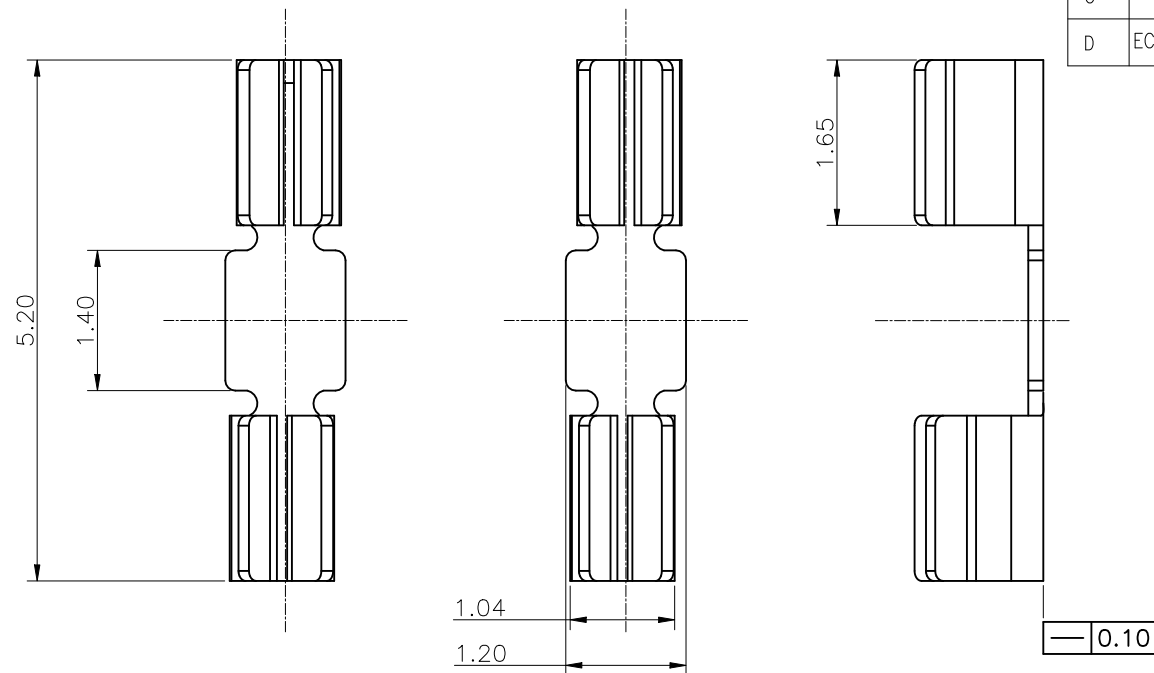

3D VIEW

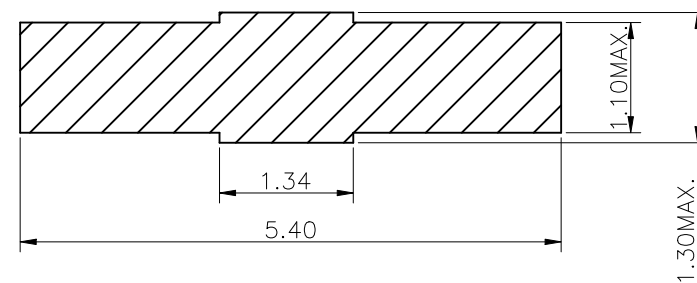

RECOMMENDED PCB LAYOUT

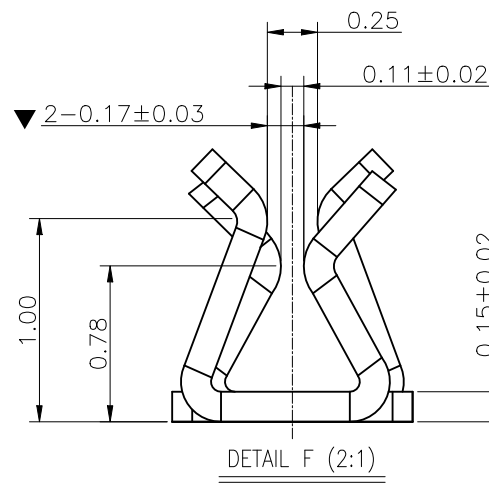
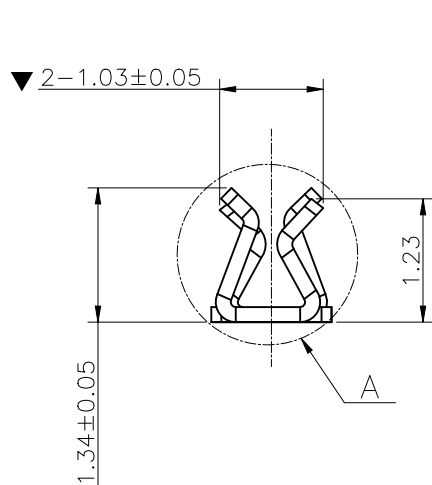

NOTES:

1. MATERIAL: SUS 304 T=0.15mm;
2. FINISH: Tin 80-160u" PLATING OVER ALL, Ni 40-120u" UNDER PLATING OVER ALL.
3. ALL MATERIAL MUST BE COMPLY WITH RoHS2.0
4. "▼" NOTATION FOR IMPORTANT DIMENSION.

UNLESS OTHERWISE SPECIFIED TOLERANCES				ANGLE OF PROJECTION		Amphenol AORORA	
X.	±0.30	X. *	± 5'			Amphenol Aorora Technology (Huizhou) Co.,Ltd	
X.X	±0.25	X.X *	± 4'				
X.XX	±0.20	X.XX *	± 3'	Customer Drw		TITLE: HI. 34 CLIP	
X.XXX	±0.15	X.XXX *	± 2'	DOC TYPE			
LINEAR DIMS		ANGLES DIMS		DRAWN	DATE	DeMing Li	
DWG NO.: A-S0179				DESIGN	DATE	DeMing Li	
MATERIAL		SEE NOTES		CHECKED	DATE	Qi Han	
FINISHED		SEE NOTES		APPROVED	DATE	Hongkui Liu	
						SIZE	PART NUMBER:
						A4	Z000-4G7U1-11000
						SCALE	1:1
						UNIT	mm
						SHEET	1 OF 1
						REV.	D

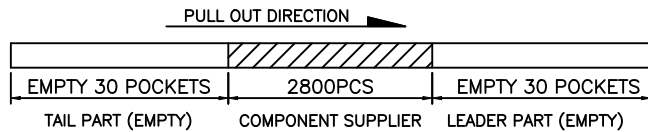
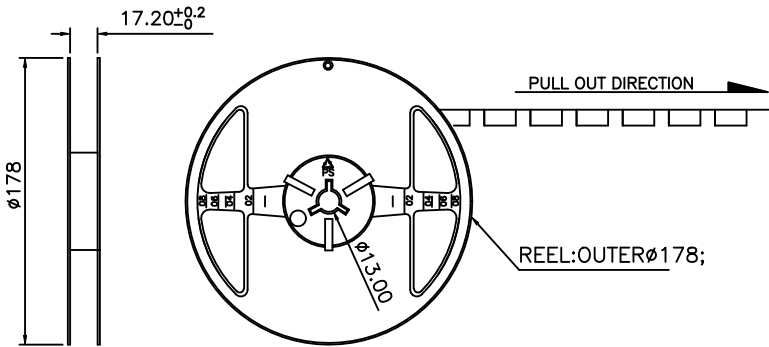
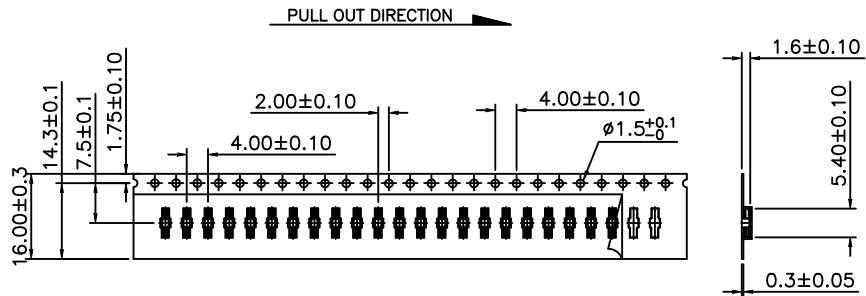

REV.	ECR/ECN No.	DESCRIPTION	DRAWN/DATE	CHECKED/DATE	APPROVED/DATE
B		ADD PART NUMBER	Staven 2018-05-12	Muyuan Liu 2018-05-12	Judy 2018-05-12
C	ECN2022152	UPDATE FRAME	Abner 2022-09-27	Staven 2022-09-27	Sam 2022-09-27

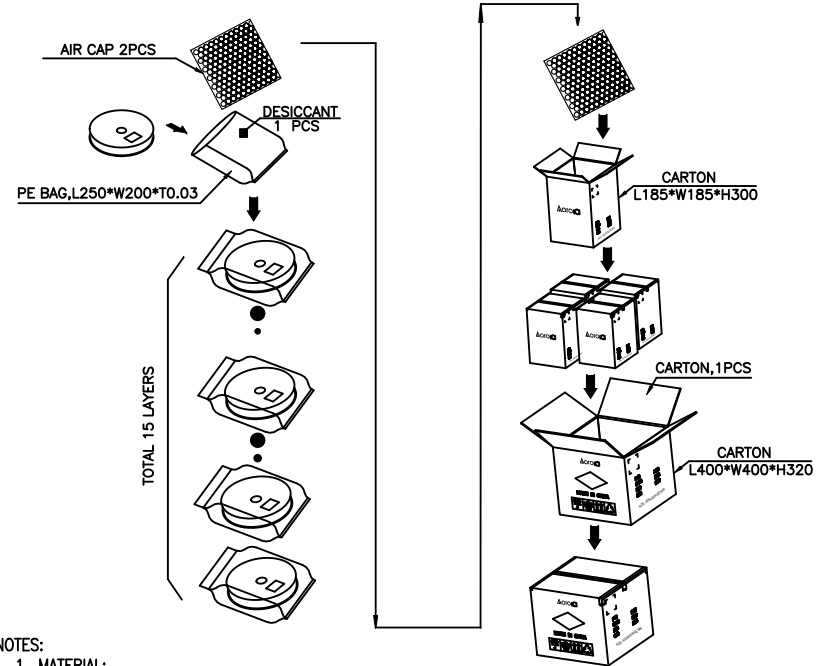

NOTES:

- MATERIAL:
  - CARRY TAPE:HIPS,T=0.30mm,CLEAR
  - REEL:HIPS,BLUE.
  - SHIM:PE,CLEAR.
- PRIMARY PACKING:2800PCS/REEL.
- SECONDARY PACKING:"N"REELS/CARTON ("TOTAL"=60\*2800/CARTON).
- PEELING RESISTANCE: 0.2N~1.2N(20~120gf);  
PEELING ANGLE: 165°~180°;  
PEELING SPEED: 300mm/minutes.
- QTY LIST:

PRODUCT	PCS/REEL	inside BOX (TOL:PCS)	outside BOX (TOL:PCS)
H1.34 CLIP	2800PCS	15REEL(42000PCS)	4BOX(168000PCS)

UNLESS OTHERWISE SPECIFIED TOLERANCES				ANGLE OF PROJECTION		Amphenol AORORA	
X.	±0.15	X. °	± 1°			Amphenol AORORA Technology (Huizhou) Co.,Ltd TITLE: H1.34 CLIP PACKING	
X.X	±0.16	X.X °	± 0.5°				
X.XX	±0.05	X.XX °	± 0.5°	DOC TYPE		PACKING DWG.	
X.XXX	±0.03	X.XXX °	± 1°	DRAWN	DATE	Staven	2018-05-12
LINEAR DIMS		ANGLES DIMS		DESIGN	DATE	Staven	2018-05-12
DWG NO.: A-H0110				CHECKED	DATE	MUYUAN LIU	2018-05-12
MATERIAL		SEE NOTES		APPROVED	DATE	Judy	2018-05-12
FINISHED		SEE NOTES		SCALE		1:1	UNIT : mm
				SHEET		1	OF 1