

PART NUMBER	REVISION	DESCRIPTION	FEED TYPE
2151825-2	C	FINE CRIMP HEIGHT ADJUST	PNEUMATIC
7-2151825-2	C	PNEUMATIC AND CRIMP TOOLING KIT	PNEUMATIC
7-2151825-7	A	CRIMP TOOLING KIT	-

ATLANTIC VERSION TERMINATOR INTERFACE ADAPTER

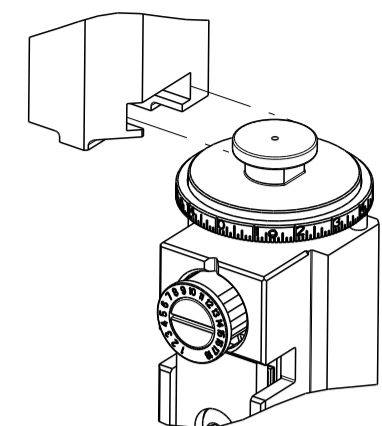

APPLICATOR DATA		
CRIMP	SIZE	TYPE
WIRE	5.33 mm [.210]	F
INSUL	7.11 mm [.280]	O

APPLICATOR INSTRUCTIONS 408-35042

TERMINAL DATA: LEAR TERMINAL		LEAR CRIMP SPECIFICATION	
TERMINAL NAME: FLAT CONTACT 8x0.8/9.5x1.2			
WIRE STRIP LENGTH		INSULATION DIAMETER RANGE	
8.00-8.02 mm [.315-.316 IN]		Ø4.10-6.00 mm [1.61-.236 IN]	
TERMINAL APPLICATION SPECIFICATION	N.106.867 Rev 8		
TERMINALS APPLIED			
TE TERMINAL	LEAR TERMINAL	TE TERMINAL	LEAR TERMINAL
2113306-1	28490306189		

WIRE SIZE	CRIMP HEIGHT mm [INCH]	CRIMP HEIGHT REFERENCE SETTING
10.00mm2	3.30+0.10/-0.05 [1.130+.004/-0.002]	5.0
6.00mm2	3.00+/-0.05 [1.118+/-0.002]	7.7

- RECOMMENDED SPARE PARTS
- REFER TO SUPPLIED INSTRUCTION SHEET FOR CLEANING, LUBRICATION AND STORAGE OF APPLICATOR.
- APPLY PART NUMBER 2-23419-6 LOCTITE TO THREADS OF ITEM 242. APPLY PART NUMBER 1-23419-5 LOCTITE TO THREADS OF ITEM 180.
- CRIMP HEIGHT REFERENCE SETTING WAS THE SETTING USED WHEN THE APPLICATOR WAS QUALIFIED AT THE FACTORY. ADJUSTMENT MAY BE NECESSARY WHEN RUNNING APPLICATOR IN THE FIELD.
- APPLICATOR NOT RECOMMENDED IN PRESS WITH INSUFFICIENT TONNAGE.
- TERMINAL PITCH NOT COMPATIBLE WITH MECHANICAL FEED.
- RELOCATE ITEM 19 TO BACK OF APPLICATOR.
- 8. UNLESS SPECIFIED OTHERWISE TORQUE VALUES SHALL BE USED PER DOCUMENT, 101-35000.

**\*WARNING**  
 ON INSTALLATION, SET WIRE DISC TO CRIMP HEIGHT REFERENCE SETTING FOR LARGEST WIRE SIZE. CRIMP HEIGHT REFERENCE SETTINGS GREATER THAN THE VALUE SHOWN MAY CAUSE DAMAGE TO THE CRIMP TOOLING. REFER TO THE INSTRUCTION SHEET FOR PROPER SETUP AND ADJUSTMENTS.

ATLANTIC VERSION  
 Shown on sheets 1 of 4 & 2 of 4  
 (Pacific version shown on sheets 3 of 4 & 4 of 4)

LOC	DIST	REVISIONS					
A	66	P	LTN	DESCRIPTION	DATE	OWN	APVD
		B		ECR-15-014598	05OCT2015	MR	JDG
		C		ECR-22-153782	21SEP2022	JWC	ROY

-	2	2	2168083-1	SCR, SKT HD CAP, RoHS, M3 X 8.0	267
-	1	1	2119641-1	FEED CAM, AIR FEED	248
-	1	1	2119082-6	CAM, SNAIL, INSULATION ADJUSTMENT	244
-	1	1	2079764-1	WASHER, WAVE SPRING, CREST-TO-CREST	243
3	-	1	2119083-1	RETAINER, INSULATION DIAL	242
-	1	1	7-18023-7	SCR, SKT HD CAP M3 X 4.0	241
-	-	-	2119580-1	MECHANICAL FEED ASSEMBLY	239
-	1	1	2844940-2	AIR FEED MODULE	238
3	-	1	2-1752354-7	STANDOFF, HOLD-DOWN	180
-	1	1	6-993111-6	PIN, SLOTTED SPRING 3.0 X 14.0	177
-	1	1	8-22280-7	SPRING, COMPRESSION	176
-	1	1	1752353-2	GUIDE PIN, HOLDDOWN	175
-	1	1	1901680-2	GUIDE PIN, HOLDDOWN	174
-	REF	REF	994970-2	COUNTER, MAGNETIC	164
-	1	1	1-22281-8	SPRING, COMPRESSION	158
-	1	1	2168083-6	SCR, SKT HD CAP, RoHS, M5 X 6.5	155
-	1	1	455888-6	SPACER, CRIMPER	120
-	1	1	318563-1	GUARD, FRONT CHIP	119
-	1	1	2844908-1	SCREW, LOCKING	99
-	1	1	2844907-1	POST, LOCKING	98
-	1	1	2-690438-2	FRONT STRIP GUIDE	96
-	2	2	2168083-1	SCR, SKT HD CAP, RoHS, M3 X 8.0	95
-	1	1	1803078-1	SPACER, PRECISION	82
-	2	2	2079383-4	SCR, BHSC, RoHS (M4 X 8)	79
-	1	1	1803096-1	EXTENSION PLATE	78
-	1	1	1633782-3	FENCE	76
-	1	1	1803607-3	DOCUMENTATION PACKAGE	71
-	1	1	1-2119791-2	DEPRESSOR, WIRE	70
-	1	1	2119943-1	WASHER, SPACER	69
-	1	1	2119740-1	TAG, IDENTIFICATION	67
-	2	2	2168078-1	SCREW, DRIVE, RH, RoHS, 2 x .188	66
-	2	2	2-18032-5	SCR, SET, FLT PNT, M5 X 20.0	61
-	1	1	2168083-2	SCR, SKT HD CAP, RoHS, M4 X 8.0	60
-	1	1	5-18022-5	SCR, HEX HD CAP, M4 X 6.0	59
-	1	1	1-1338683-1	FEED PAWL	56
-	2	2	2168083-3	SCR, SKT HD CAP, RoHS, M4 X 12.0	54
-	1	1	1-5018030-0	NUT, HEX, REG, RoHS, M3.5	52
-	1	1	1901681-2	HOLDDOWN, TERMINAL	51
-	1	1	18023-9	SCR, SKT HD CAP M4 X 6.0	49
-	-	-	2119652-1	FEED CAM, PRE FEED	48
-	-	-	2119653-1	FEED CAM, POST FEED	47
-	1	1	1-1803583-7	APPLICATOR BASIC ASSEMBLY, SF	46
-	1	1	1803515-2	RAM ASSEMBLY, SF ATLANTIC	44
-	1	1	1803602-2	SCR, BHSC, RoHS (M8 X 40)	41
-	1	1	4-1752356-5	SUPPORT, TERMINAL	34
-	2	2	1-2079383-3	SCR, BHSC, RoHS (M4 X 25)	33
-	2	2	3-2844962-7	SPACER, CYLINDRICAL, STRIP GUIDE	30
-	1	1	2844938-9	PLATE, STRIP GUIDE	29
-	1	1	1-455888-0	SPACER, CRIMPER	28
-	2	2	22281-8	SPRING, COMPRESSION	27
-	1	1	356835-1	LEVER, DRAG RELEASE	26
-	1	1	240792-1	DRAG, TERMINAL	25
-	1	1	1320928-6	STRIP GUIDE	24
-	1	1	980371-4	SCR, SKT HD SHLDR 5.0 DIA X 6.0	23
-	1	1	2168083-2	SCR, SKT HD CAP, RoHS, M4 X 8.0	21
-	2	2	1-18028-2	WASHER, FLAT, REG M4	20
1	-	1	1803013-1	STRIPPER, SIDE FEED	19
-	1	1	2119806-1	INSERT, SHEAR	13
-	1	1	4-22280-7	SPRING, COMPRESSION	12
-	1	1	1-356885-3	STOP, SHEAR	11
-	1	1	1-2119805-0	SHEAR HOLDER, FRONT	10
-	1	1	1-318059-0	FLOATING SHEAR, FRONT	9
1	2	1	2-1333229-3	ANVIL, COMBINATION	8
-	-	-	-	-	7
-	-	-	-	-	6
-	1	1	1803080-1	DEPRESSOR, SHEAR	5
-	1	1	238011-1	BLOCK, CRIMPER SPACER	4
1	2	1	1-1803017-4	CRIMPER, INSULATION F	3
-	1	1	1-455888-4	SPACER, CRIMPER	2
1	2	1	456430-2	CRIMPER, WIRE	1

DIMENSIONS:		TOLERANCES UNLESS OTHERWISE SPECIFIED:		MATERIAL:		FINISH:		WEIGHT:		SCALE:	
mm	0 PLC ±	1 PLC ±	2 PLC ±	3 PLC ±	4 PLC ±	ANGLES	FINISH	-	-	1:2	SHEET 1 OF 4
APPLICATOR DATA		APPLICATOR DATA		APPLICATOR DATA		APPLICATOR DATA		APPLICATOR DATA		APPLICATOR DATA	
APPLICATOR DATA		APPLICATOR DATA		APPLICATOR DATA		APPLICATOR DATA		APPLICATOR DATA		APPLICATOR DATA	

LOC	DIST	REVISIONS					
		P	LTN	DESCRIPTION	DATE	DWN	APVD
A	66	-	-	SEE SHEET 1	-	-	-

# FEED TYPE

## PNEUMATIC

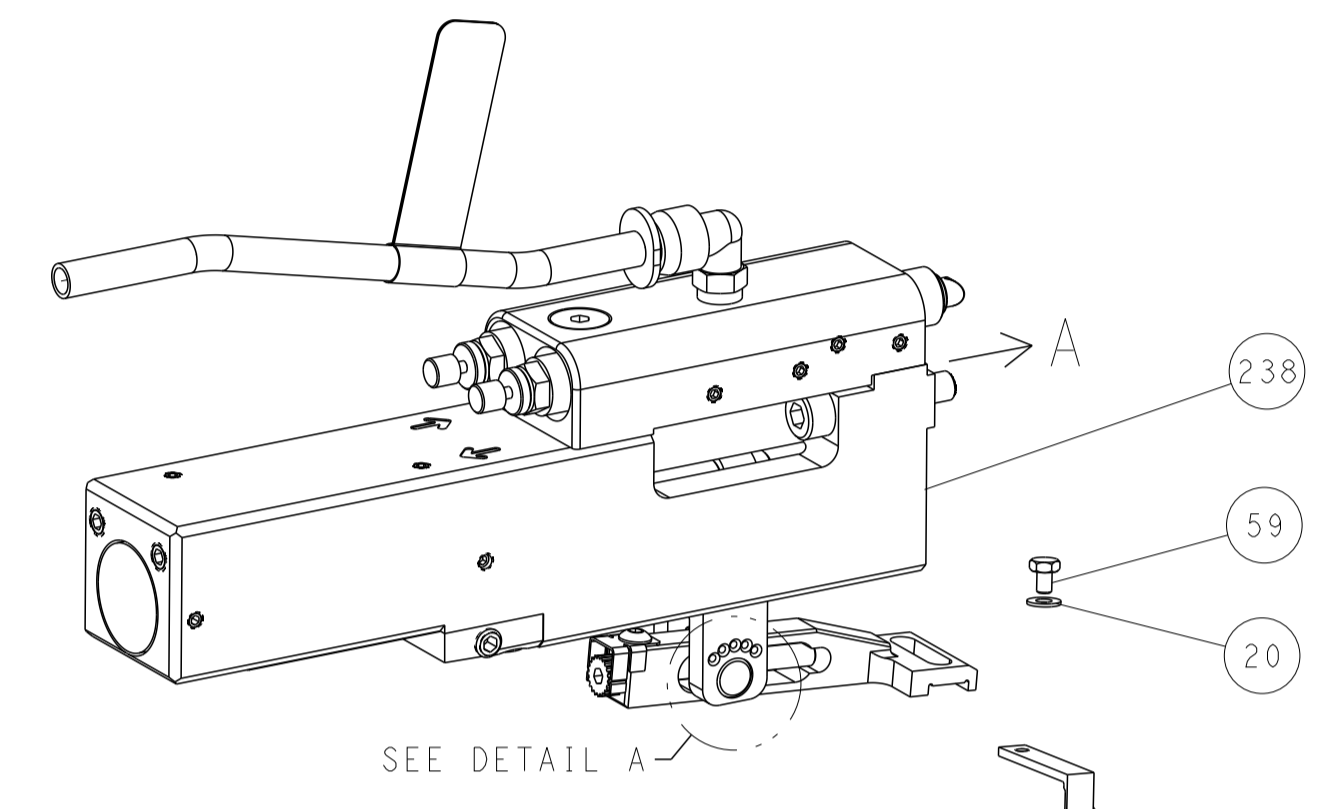

SEE DETAIL A

## FEED SPRING SETTING POSITION (SHOWN FROM REAR SIDE)

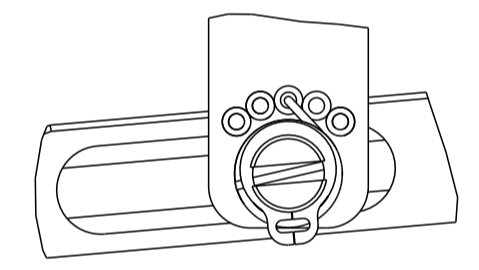

DETAIL A

## CAM POSITION

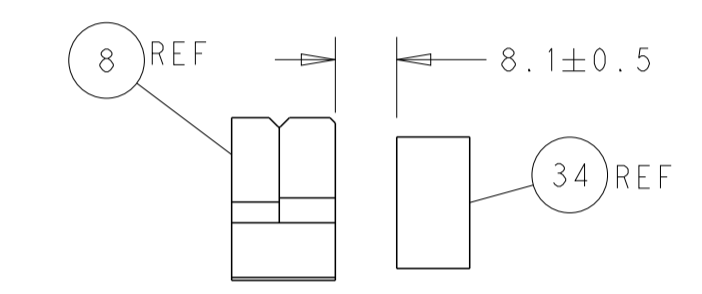
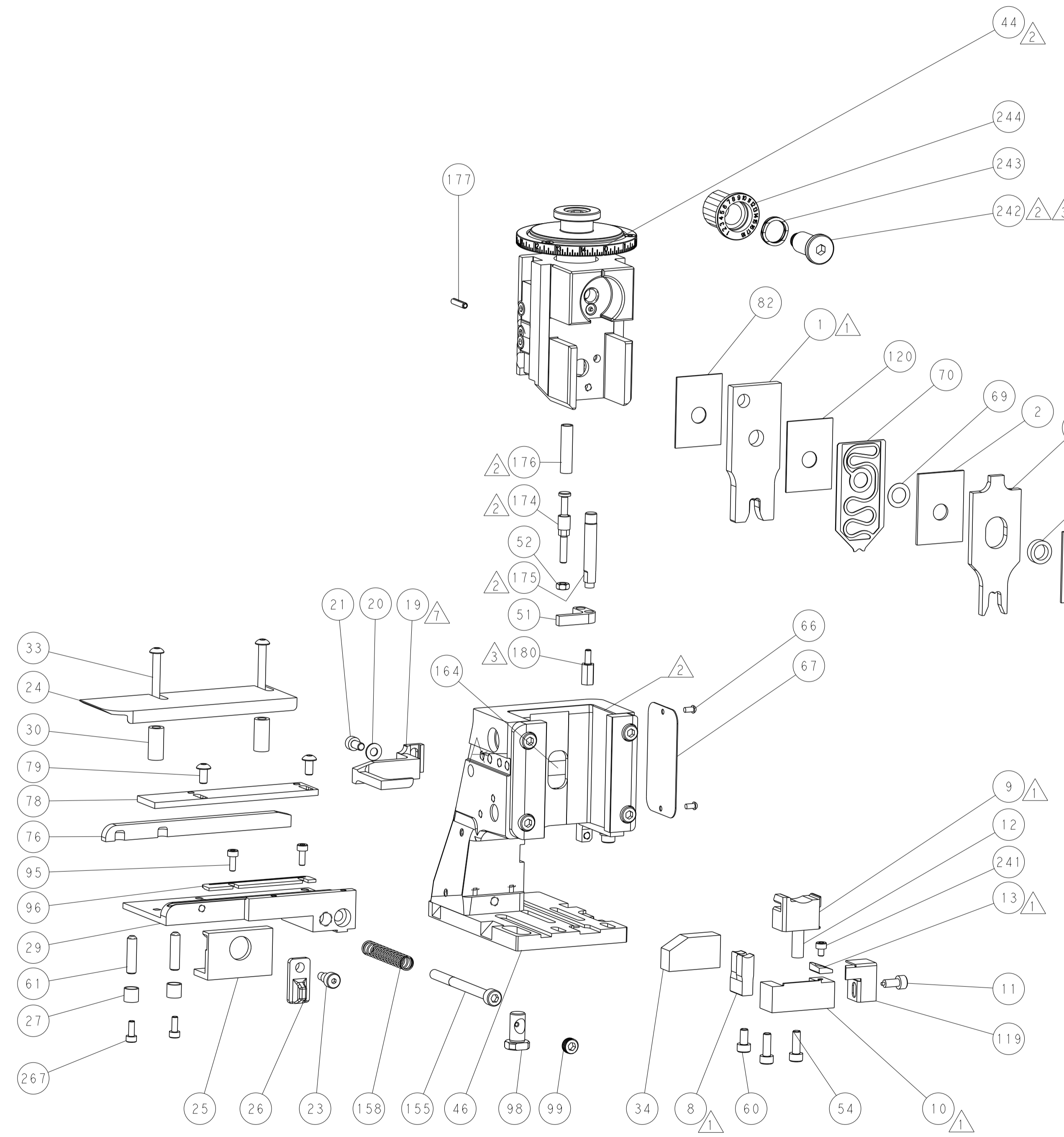
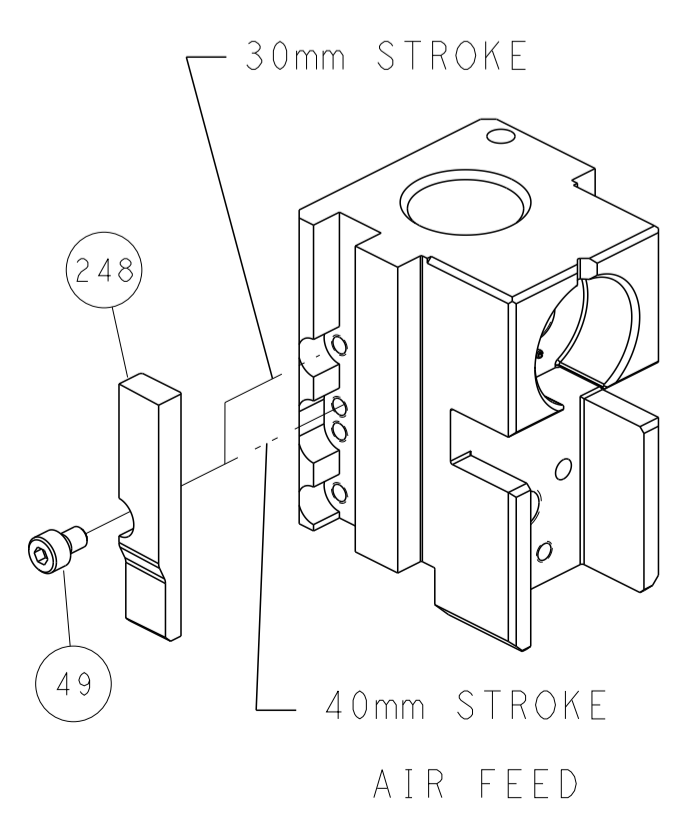

TERMINAL SUPPORT LOCATION

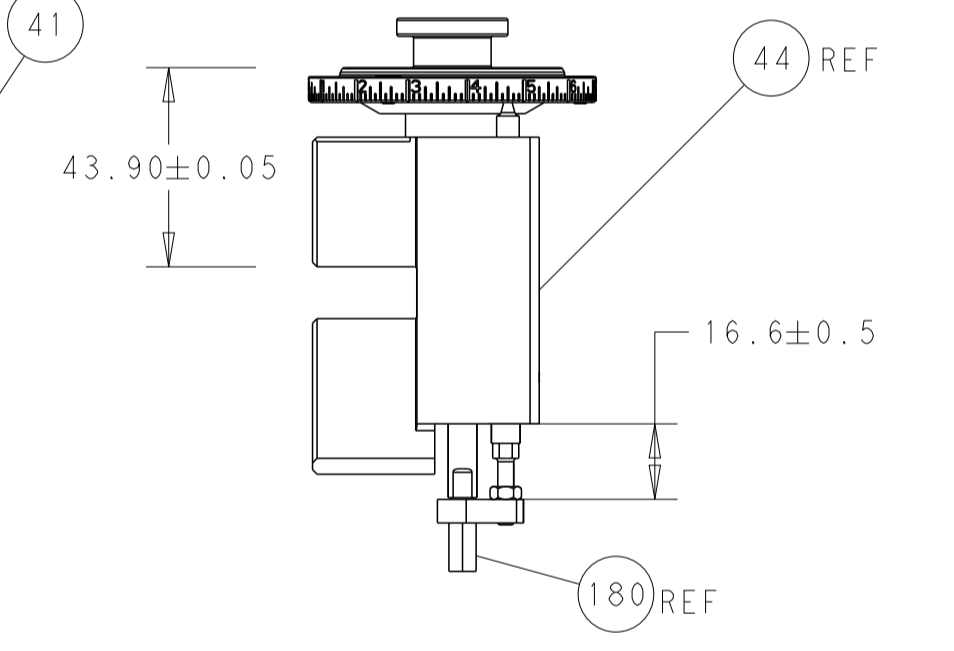

RAM AND HOLDDOWN SET-UP

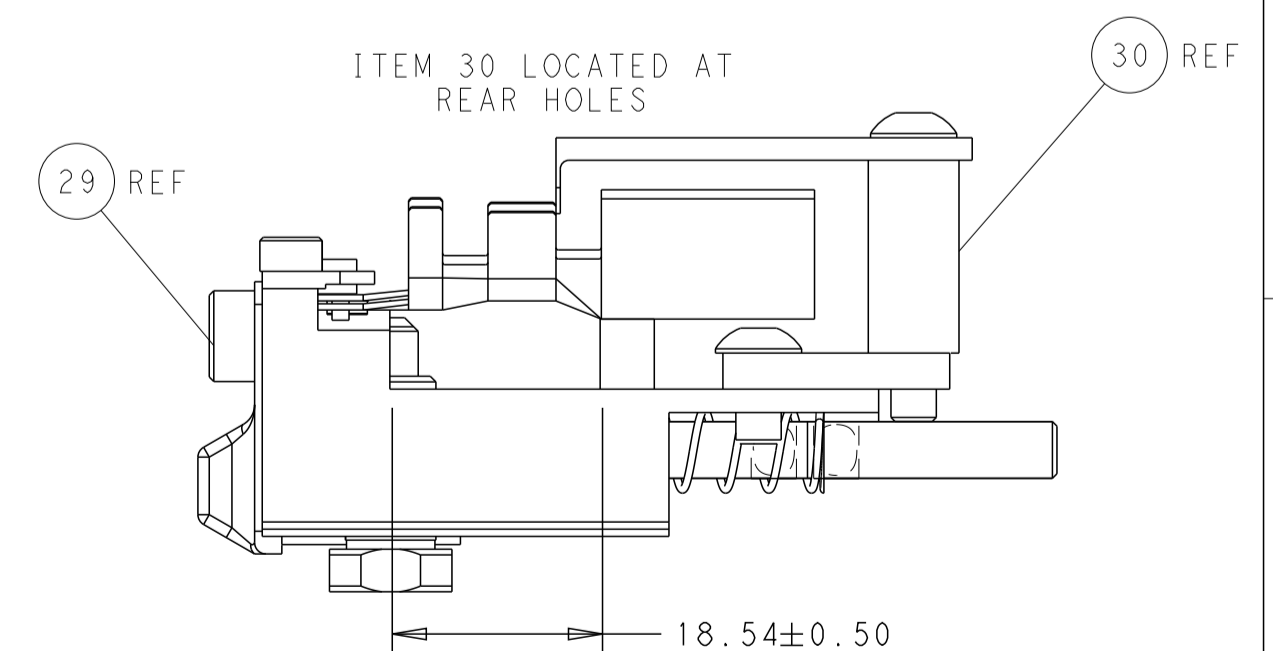

FEED TRACK POSITION GUIDE BY WIRE BARREL

**ATLANTIC VERSION**  
 Shown on sheets 1 of 4 & 2 of 4  
 (Pacific version shown on sheets 3 of 4 & 4 of 4)

DIMENSIONS: mm 		TOLERANCES UNLESS OTHERWISE SPECIFIED: 0 PLC ± 1 PLC ± 2 PLC ± 3 PLC ± 4 PLC ± ANGLES ± FINISH ±		DWN R.O. WILSON 19DEC2012 CHK K. J. STAKEM 28DEC2012 APVD T. L. ELBIN 28DEC2012 PRODUCT SPEC APPLICATION SPEC WEIGHT SCALE 1:2		NAME Ocean Side Feed Applicator SIZE CAGE CODE DRAWING NO. RESTRICTED TO A1 00779 C=2151825 2 OF 4 REV C	
MATERIAL:				Customer Accessible Production Drawing			

THIS DRAWING IS UNPUBLISHED.	RELEASED FOR PUBLICATION		
COPYRIGHT 20 BY TYCO ELECTRONICS CORPORATION. ALL RIGHTS RESERVED.			
PART NUMBER	REVISION	DESCRIPTION	FEED TYPE
2-2151825-2	C	FINE CRIMP HEIGHT ADJUST	PNEUMATIC
7-2151825-7	A	CRIMP TOOLING KIT	-

PACIFIC VERSION TERMINATOR INTERFACE ADAPTER

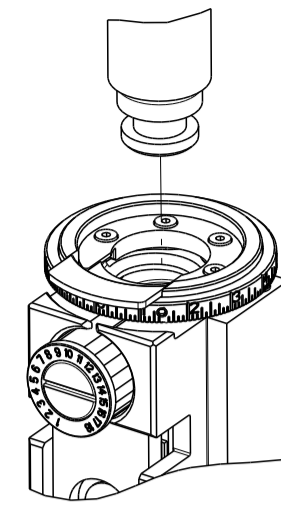

APPLICATOR DATA		
CRIMP	SIZE	TYPE
WIRE	5.33 mm [.210]	F
INSUL	7.11 mm [.280]	O
APPLICATOR INSTRUCTIONS 408-35042		

TERMINAL DATA: LEAR TERMINAL		LEAR CRIMP SPECIFICATION	
TERMINAL NAME: FLAT CONTACT 8x0.8/9.5x1.2			
WIRE STRIP LENGTH		INSULATION DIAMETER RANGE	
8.00-8.02 mm [.315-.316 IN]		Ø4.10-6.00 mm [.161-.236 IN]	
TERMINAL APPLICATION SPECIFICATION	N.106.867 Rev 8		
TERMINALS APPLIED <sup>6</sup>			
TE TERMINAL	LEAR TERMINAL	TE TERMINAL	LEAR TERMINAL
2113306-1	28490306189		

WIRE SIZE	CRIMP HEIGHT mm [INCH]	CRIMP HEIGHT REFERENCE SETTING
10.00mm2	3.30+0.10/-0.05 [.130+/.004/- .002]	5.0
6.00mm2	3.00+/-0.05 [.118+/- .002]	7.7

- RECOMMENDED SPARE PARTS
  - <sup>2</sup> REFER TO SUPPLIED INSTRUCTION SHEET FOR CLEANING, LUBRICATION AND STORAGE OF APPLICATOR.
  - <sup>3</sup> APPLY PART NUMBER 2-23419-6 LOCTITE TO THREADS OF ITEM 242. APPLY PART NUMBER 1-23419-5 LOCTITE TO THREADS OF ITEM 180.
  - <sup>4</sup> CRIMP HEIGHT REFERENCE SETTING WAS THE SETTING USED WHEN THE APPLICATOR WAS QUALIFIED AT THE FACTORY. ADJUSTMENT MAY BE NECESSARY WHEN RUNNING APPLICATOR IN THE FIELD.
  - <sup>5</sup> APPLICATOR NOT RECOMMENDED IN PRESS WITH INSUFFICIENT TONNAGE.
  - <sup>6</sup> TERMINAL PITCH NOT COMPATIBLE WITH MECHANICAL FEED.
  - <sup>7</sup> RELOCATE ITEM 19 TO BACK OF APPLICATOR.
8. UNLESS SPECIFIED OTHERWISE TORQUE VALUES SHALL BE USED PER DOCUMENT, 101-35000.

**\*WARNING**  
ON INSTALLATION, SET WIRE DISC TO CRIMP HEIGHT REFERENCE SETTING FOR LARGEST WIRE SIZE. CRIMP HEIGHT REFERENCE SETTINGS GREATER THAN THE VALUE SHOWN MAY CAUSE DAMAGE TO THE CRIMP TOOLING. REFER TO THE INSTRUCTION SHEET FOR PROPER SETUP AND ADJUSTMENTS.

**PACIFIC VERSION**  
Shown on sheets 3 of 4 & 4 of 4  
(Atlantic version shown on sheets 1 of 4 & 2 of 4)

LOC	DIST	REVISIONS					
A	66	P	LTN	DESCRIPTION	DATE	OWN	APVD
		-		SEE SHEET 1	-	-	-

-	2	2168083-1	SCR, SKT HD CAP, RoHS, M3 X 8.0	267
-	1	2119082-6	CAM, SNAIL, INSULATION ADJUSTMENT	244
-	1	2079764-1	WASHER, WAVE SPRING, CREST-TO-CREST	243
<sup>3</sup>	-	2119083-1	RETAINER, INSULATION DIAL	242
-	1	7-18023-7	SCR, SKT HD CAP M3 X 4.0	241
-	-	2119580-1	MECHANICAL FEED ASSEMBLY	239
-	1	2844940-2	AIR FEED MODULE	238
<sup>3</sup>	-	2-1752354-7	STANDOFF, HOLD-DOWN	180
-	1	6-993111-6	PIN, SLOTTED SPRING 3.0 X 14.0	177
-	1	8-22280-7	SPRING, COMPRESSION	176
-	1	1752353-2	GUIDE PIN, HOLDDOWN	175
-	1	1901680-2	GUIDE PIN, HOLDDOWN	174
-	REF	994970-2	COUNTER, MAGNETIC	164
-	1	1-22281-8	SPRING, COMPRESSION	158
-	1	2168083-6	SCR, SKT HD CAP, RoHS, M5 X 65	155
-	1	2119641-2	FEED CAM, AIR FEED	151
-	1	2168083-8	SCR, SKT HD CAP, RoHS, M4 X 16	144
-	2	2168083-9	SCR, SKT HD CAP, RoHS, M4 X 20	143
-	-	2119653-2	FEED CAM, POST FEED	142
-	1	1-1803583-8	APPLICATOR BASIC ASSEMBLY, SF	141
-	1	1803516-2	RAM ASSEMBLY, SF PACIFIC	140
-	1	455888-6	SPACER, CRIMPER	120
-	1	318563-1	GUARD, FRONT CHIP	119
-	1	2844908-1	SCREW, LOCKING	99
-	1	2844907-1	POST, LOCKING	98
-	1	2-690438-2	FRONT STRIP GUIDE	96
-	2	2168083-1	SCR, SKT HD CAP, RoHS, M3 X 8.0	95
-	1	1803078-1	SPACER, PRECISION	82
-	2	2079383-4	SCR, BHSC, RoHS (M4 X 8)	79
-	1	1803096-1	EXTENSION PLATE	78
-	1	1633782-3	FENCE	76
-	1	1803607-3	DOCUMENTATION PACKAGE	71
-	1	1-2119791-2	DEPRESSOR, WIRE	70
-	1	2119943-1	WASHER, SPACER	69
-	1	2119740-1	TAG, IDENTIFICATION	67
-	2	2168078-1	SCREW, DRIVE, RH, RoHS, 2 x .188	66
-	2	2-18032-5	SCR, SET, FLT PNT, M5 X 20.0	61
-	1	5-18022-5	SCR, HEX HD CAP, M4 X 6.0	59
-	1	1-1338683-1	FEED PAWL	56
-	1	1-5018030-0	NUT, HEX, REG, RoHS, M3.5	52
-	1	1901681-2	HOLDDOWN, TERMINAL	51
-	1	18023-9	SCR, SKT HD CAP M4 X 6.0	49
-	-	2119652-1	FEED CAM, PRE FEED	48
-	1	1803602-2	SCR, BHSC, RoHS (M8 X 40)	41
-	1	4-1752356-5	SUPPORT, TERMINAL	34
-	2	1-2079383-3	SCR, BHSC, RoHS (M4 X 25)	33
-	2	3-2844962-7	SPACER, CYLINDRICAL, STRIP GUIDE	30
-	1	2844938-9	PLATE, STRIP GUIDE	29
-	1	1-455888-0	SPACER, CRIMPER	28
-	2	22281-8	SPRING, COMPRESSION	27
-	1	356835-1	LEVER, DRAG RELEASE	26
-	1	240792-1	DRAG, TERMINAL	25
-	1	1320928-6	STRIP GUIDE	24
-	1	980371-4	SCR, SKT HD SHLDR 5.0 DIA X 6.0	23
-	1	2168083-2	SCR, SKT HD CAP, RoHS, M4 X 8.0	21
-	2	1-18028-2	WASHER, FLAT, REG M4	20
<sup>7</sup>	-	1803013-1	STRIPPER, SIDE FEED	19
<sup>1</sup>	-	2119806-1	INSERT, SHEAR	13
-	1	4-22280-7	SPRING, COMPRESSION	12
-	1	1-356885-3	STOP, SHEAR	11
<sup>1</sup>	-	1-2119805-0	SHEAR HOLDER, FRONT	10
<sup>1</sup>	-	1-318059-0	FLOATING SHEAR, FRONT	9
<sup>1</sup>	1	2-1333229-3	ANVIL, COMBINATION	8
-	-	-	-	7
-	-	-	-	6
-	1	1803080-1	DEPRESSOR, SHEAR	5
-	1	238011-1	BLOCK, CRIMPER SPACER	4
<sup>1</sup>	1	1-1803017-4	CRIMPER, INSULATION F	3
-	1	1-455888-4	SPACER, CRIMPER	2
<sup>1</sup>	1	456430-2	CRIMPER, WIRE	1

DIMENSIONS: mm		TOLERANCES UNLESS OTHERWISE SPECIFIED:		DRAWN: R.O. WILSON 19DEC2012		CHK: K.J. STARKEM 28DEC2012		APVD: T.L. ELBIN 28DEC2012		NAME: Ocean Side Feed Applicator	
0 PLC	±	1 PLC	±	2 PLC	±	3 PLC	±	4 PLC	±	5 PLC	±
ANGLES	±	FINISH	±	MATERIAL		WEIGHT		SCALE: 1:2		SHEET 3 OF 4	
Customer Accessible Production Drawing				SCALE: 1:2		SHEET 3 OF 4		REV C		PART NO: 2151825	

LOC	DIST	REVISIONS					
A	66	P	LTN	DESCRIPTION	DATE	DWN	APVD
		-		SEE SHEET 1			

### FEED TYPE PNEUMATIC

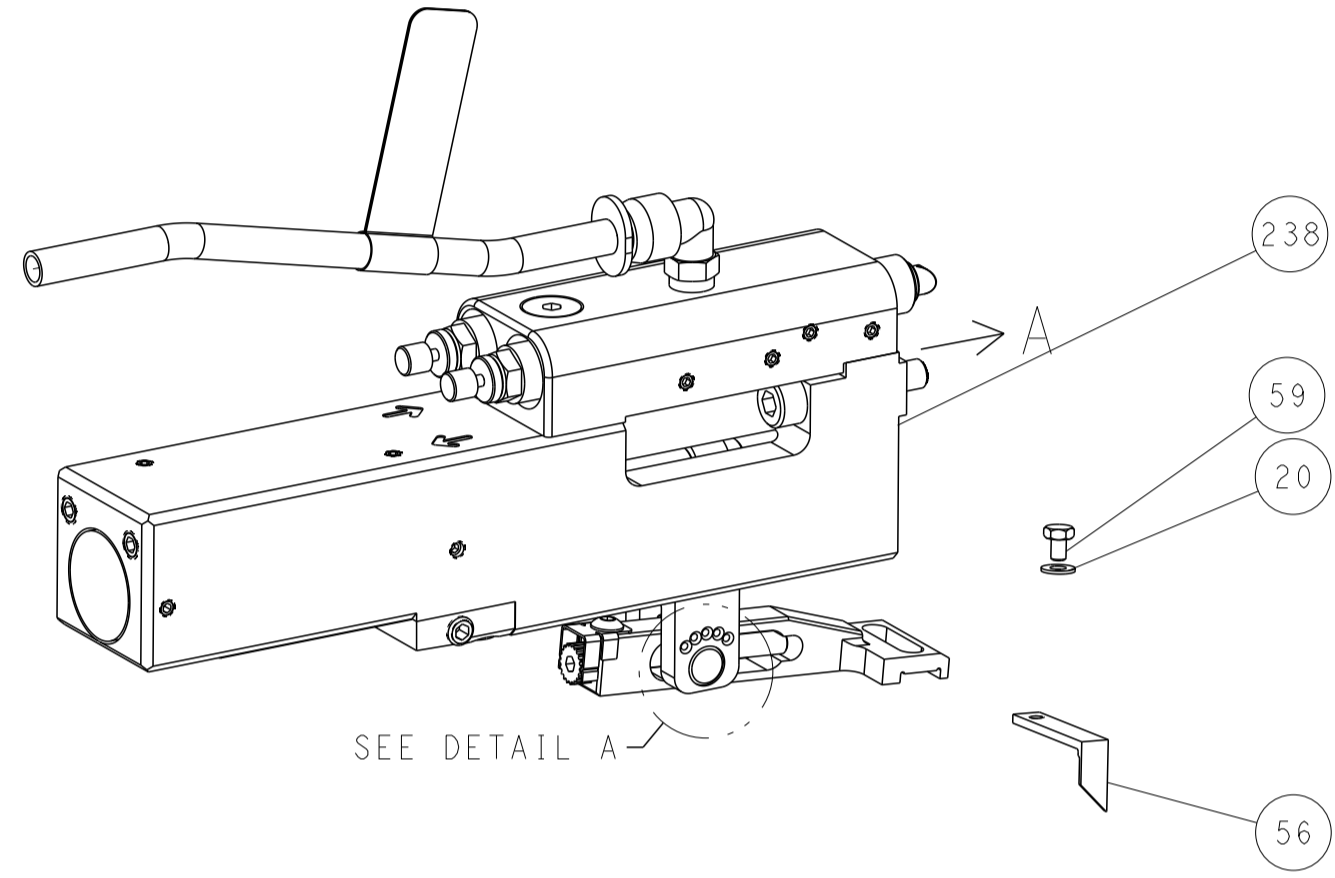

### FEED SPRING SETTING POSITION (SHOWN FROM REAR SIDE)

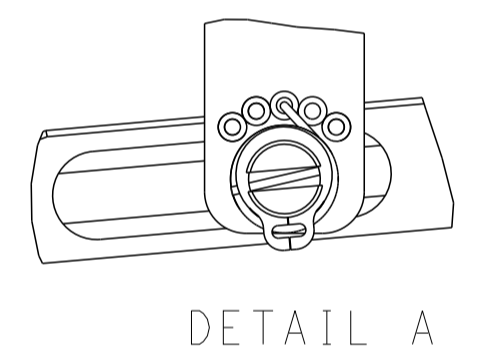

### CAM POSITION

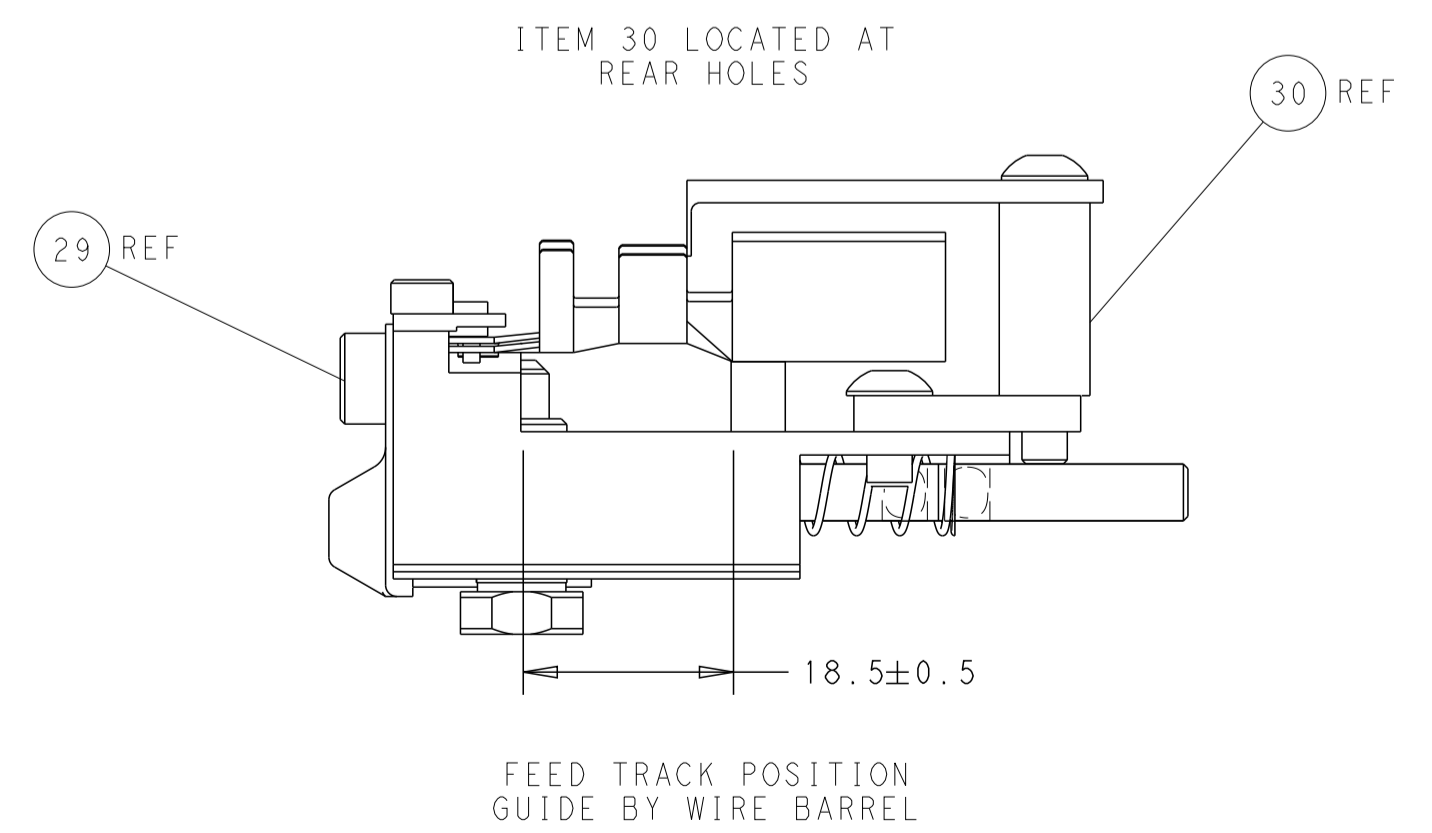
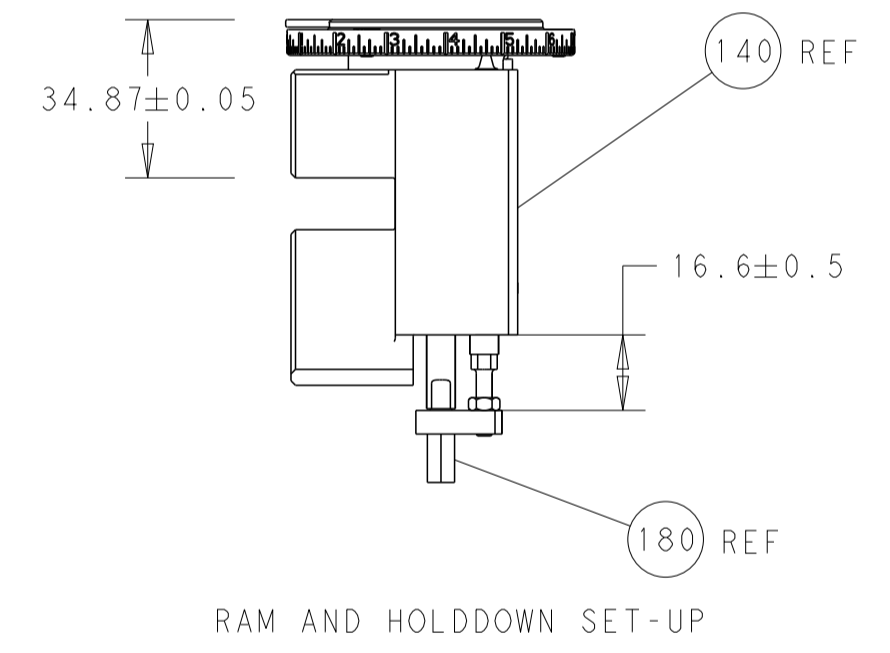
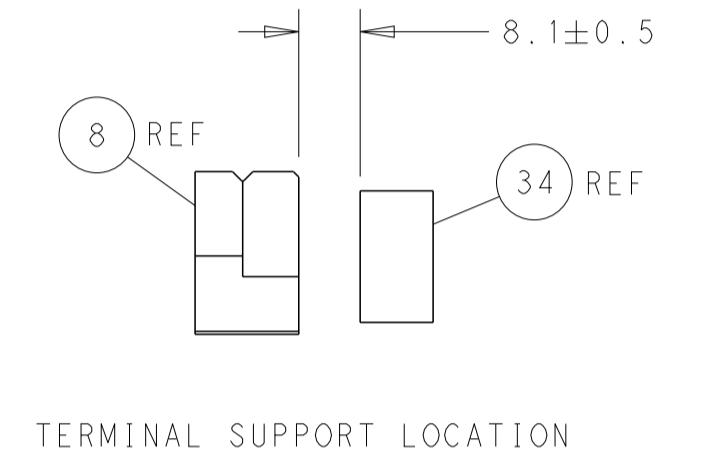
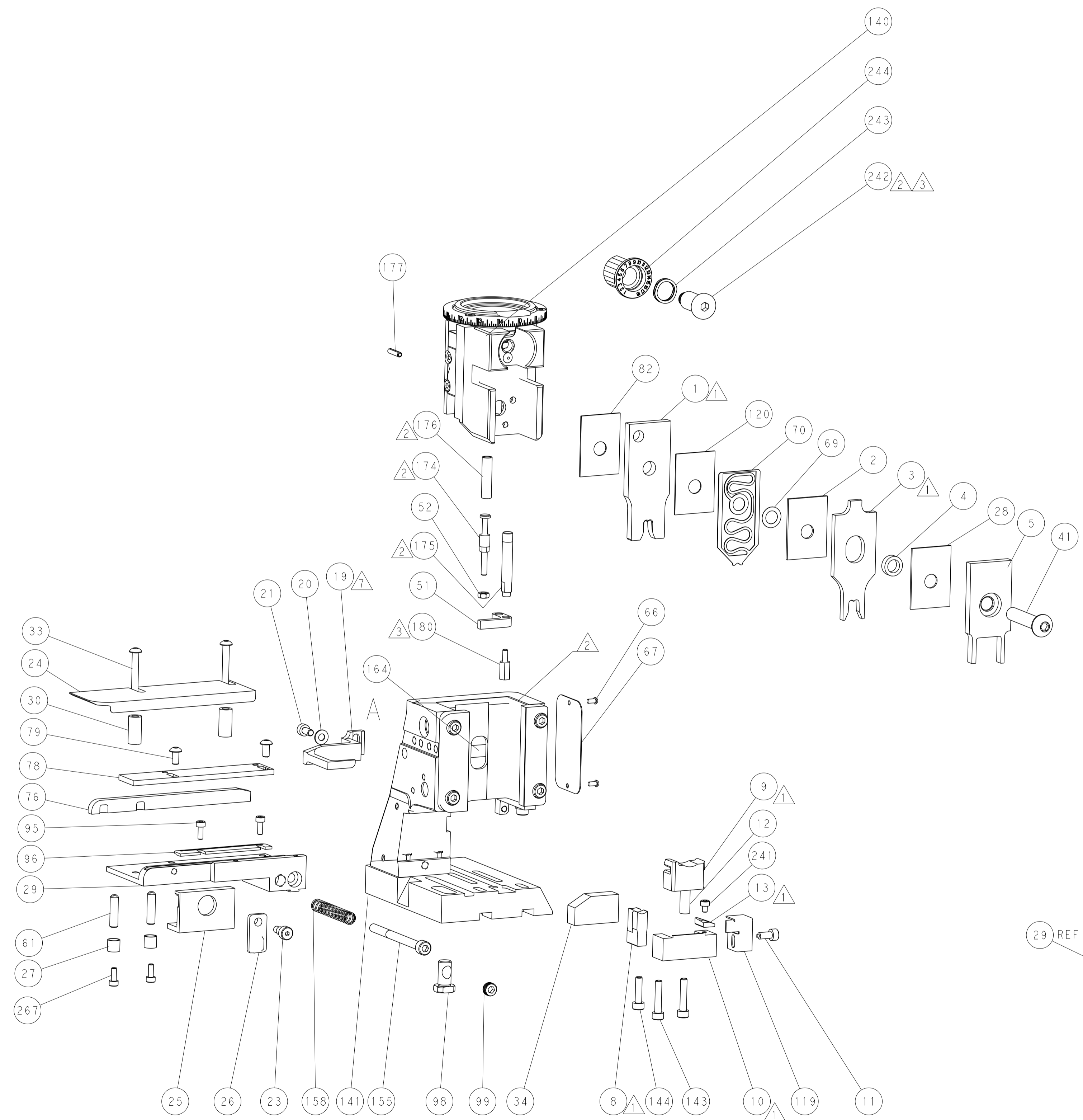
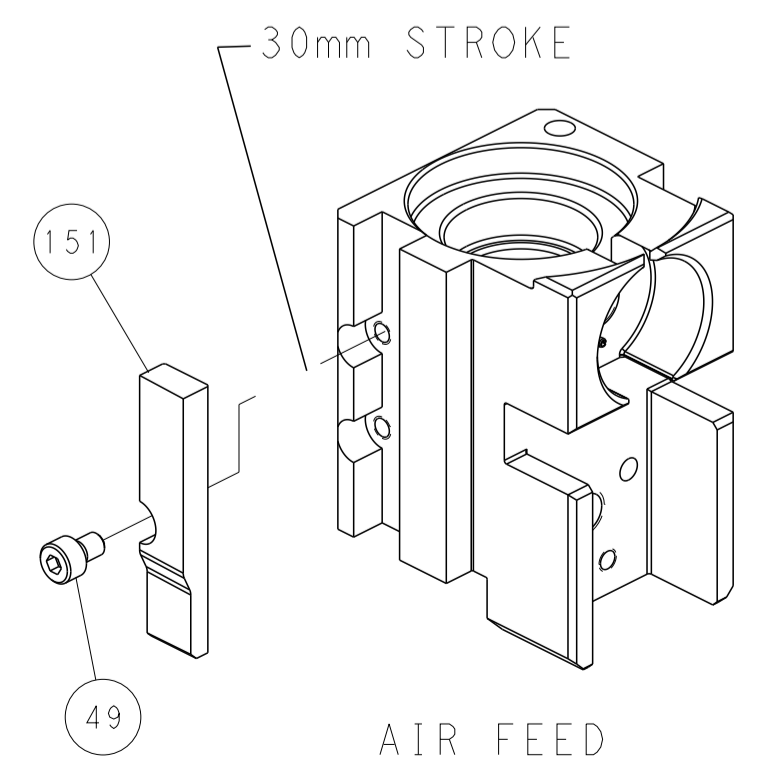

**PACIFIC VERSION**  
 Shown on sheets 3 of 4 & 4 of 4  
 (Atlantic version shown on sheets 1 of 4 & 2 of 4)

<small>THIS DRAWING IS UNPUBLISHED. RELEASED FOR PUBLICATION. ALL RIGHTS RESERVED. THIS DRAWING IS CONTROLLED DOCUMENT. FOR THE ELECTRONICS CORPORATION. IT IS THE POLICY OF THE CORPORATION TO CONTROL THE DISTRIBUTION OF THIS DRAWING TO THE EXTENT NECESSARY TO PROTECT THE CORPORATION'S INTERESTS.</small>		DWN: R.O. WILSON CHK: K.J. STAKEM APVD: T.L. ELBIN	19DEC2012 28DEC2012 28DEC2012	NAME: Ocean Side Feed Applicator SIZE: A1 CAGE CODE: 00779 DRAWING NO: C-2151825	RESTRICTED TO: C
DIMENSIONS: mm TOLERANCES UNLESS OTHERWISE SPECIFIED: 0 PLC ± 1 PLC ± 2 PLC ± 3 PLC ± 4 PLC ± ANGLES ± MATERIAL: - FINISH: -	WEIGHT: - SCALE: 1:2 SHEET: 4 OF 4 REV: C	Customer Accessible Production Drawing			