

THIS DRAWING IS UNPUBLISHED. RELEASED FOR PUBLICATION
 © COPYRIGHT BY TYCO ELECTRONICS CORPORATION. ALL RIGHTS RESERVED.

LOC	DIST	REVISIONS					
		P	LTR	DESCRIPTION	DATE	DWN	APVD
G	02		R2	REV PER ECR-06-001930	13FEB06	HMR	TM

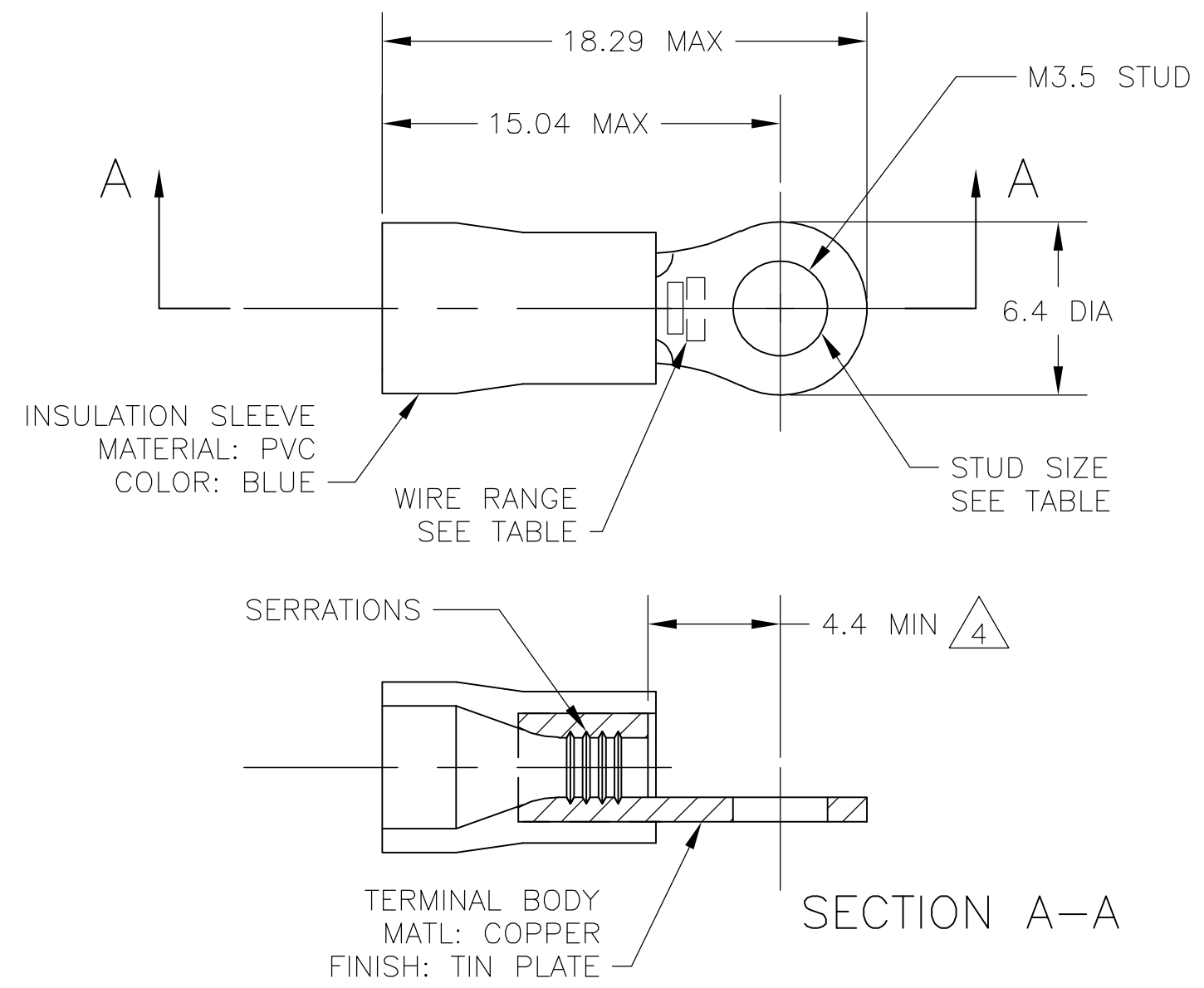

- 1 WIRE SIZE IS 16-14 AWG
- 2 WIRE INSULATION DIA: 3.0-4.9
- 3 MATERIAL THICKNESS IS 0.8
- $\triangle 4$ DIMENSION APPLIES FROM EDGE OF METAL WIRE BARREL TO END OF PIN.
- $\triangle 5$ SUPERSEDED BY 342142-1
- $\triangle 6$ OBSOLETE, NO REPLACEMENT

BULK	SCANDINAVIAN	5000	$\triangle 6$	8-342142-7
POLY BAG WITH HEADER	STANDARD	100	$\triangle 5$	7-342142-1
PLASTIC BOX	STANDARD	100	$\triangle 5$	6-342142-1
TAPED MOUNTED	STANDARD	5000		2-342142-1
PLASTIC BAG	STANDARD	100		342142-1
PACKAGING	LABELLING	QTY		PART NO

THIS DRAWING IS A CONTROLLED DOCUMENT.		DWN jr ruth 02DEC05	Tyco Electronics Corporation Harrisburg, PA 17105-3608	
DIMENSIONS: INCHES		CHK T MICHIELUTTI 02DEC05	NAME TERMINAL, RING TONGUE, PLASTI-GRIP,	
TOLERANCES UNLESS OTHERWISE SPECIFIED:		APVD T MICHIELUTTI 02DEC05	PRODUCT SPEC	
0 PLC ± -		APPLICATION SPEC		
1 PLC ± 0.5		SIZE A2		
2 PLC ± -		CAGE CODE 00779		
3 PLC ± -		DRAWING NO C=342142		
4 PLC ± -		RESTRICTED TO		
ANGLES ± 1°		SCALE 5:1		
MATERIAL		SHEET 1 of 1		
FINISH		REV R2		
CUSTOMER DRAWING				