

LOC		DIST		REVISIONS			
P	LTR	DESCRIPTION	DATE	DWN	APVD		
C		REVISED	22JUL2009	DH	JE		
CI		REVISED PER ECO-10-001873	18FEB2010	DH	JE		
D		REVISED PER ECO-11-009841	5-12-11	BM	WA		

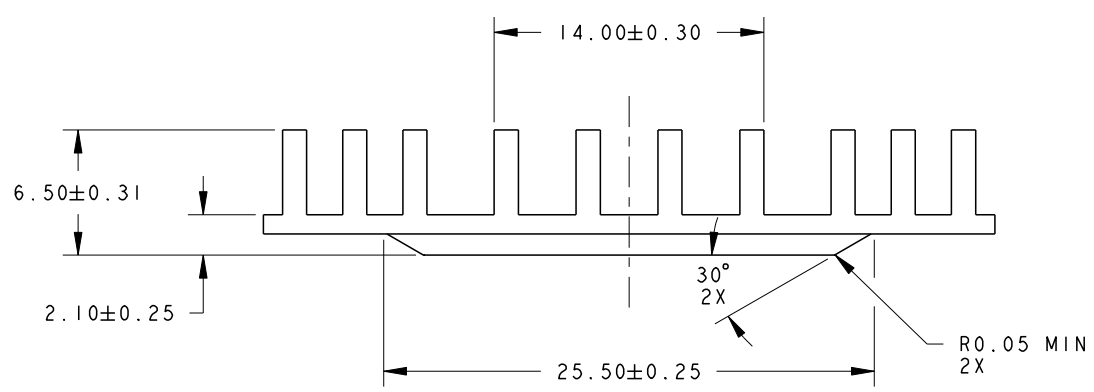
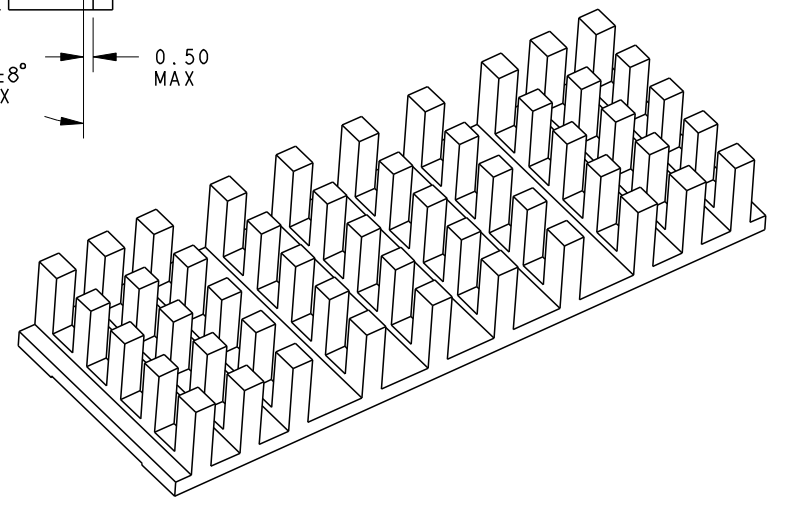
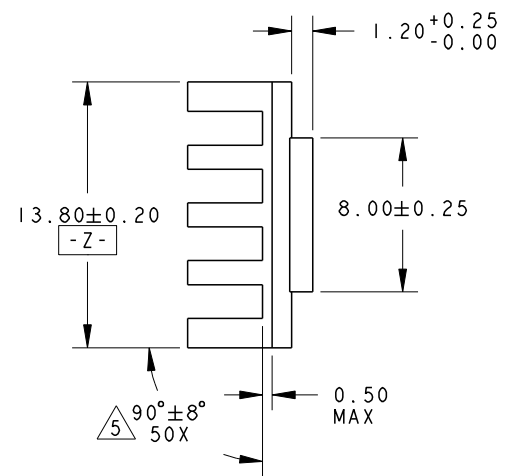
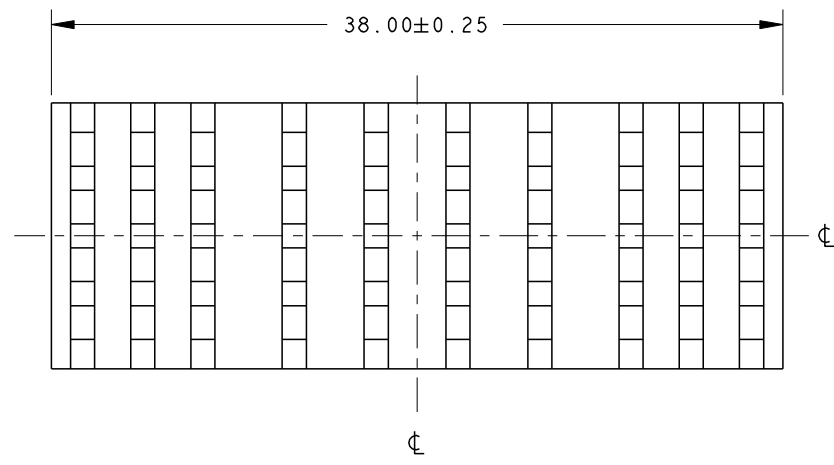

- NOTES:
 UNLESS OTHERWISE SPECIFIED
- 1 MATERIAL: 6063 ALUMINUM.
 - 2 FINISH: ELECTROLESS NICKEL 0.76-2.54 MICROMETERS THICK. RoHS COMPLIANT.
 3. 0,2mm MAX BURR.
 4. VARIATION IN PLATING COLOR IS NORMAL AND ALLOWED.
 - 5 MAXIMUM PIN LEAN OF 8° IN ANY DIRECTION.
 6. RoHS COMPLIANT AND CERTIFIED.

2	1829904-3
FINISH	PART NUMBER

<small>THIS DRAWING IS A CONTROLLED DOCUMENT FOR TYCO ELECTRONICS CORPORATION. IT IS SUBJECT TO CHANGE AND THE CONTROLLING ENGINEERING ORGANIZATION SHOULD BE CONTACTED FOR THE LATEST REVISION.</small>		DWN	E.TAO	6-26-06	Tyco Electronics Tyco Electronics Harrisburg, PA 17105-3608		
DIMENSIONS: mm		CHK	-	-	NAME HEAT SINK SFP DWDM 6.5mm TALL		
TOLERANCES UNLESS OTHERWISE SPECIFIED: 0 PLC ±.2 1 PLC ±.10 2 PLC ±.08 3 PLC ±.08 4 PLC ±0.0001 ANGLES ±5 FINISH		APVD	-	-	PRODUCT SPEC - APPLICATION SPEC -		
MATERIAL	1	WEIGHT	-	SIZE	A200779	DRAWING NO	C=1829904
FINISH 2		CUSTOMER DRAWING	SCALE	4:1	SHEET	1	OF 1
						REV	D