

REV.	DESCRIPTION	DATE	APPROVED
A	Engineering Update w/o Changes	02/23/04	M. C.
B	Removed Material Code	05/23/16	J. C.

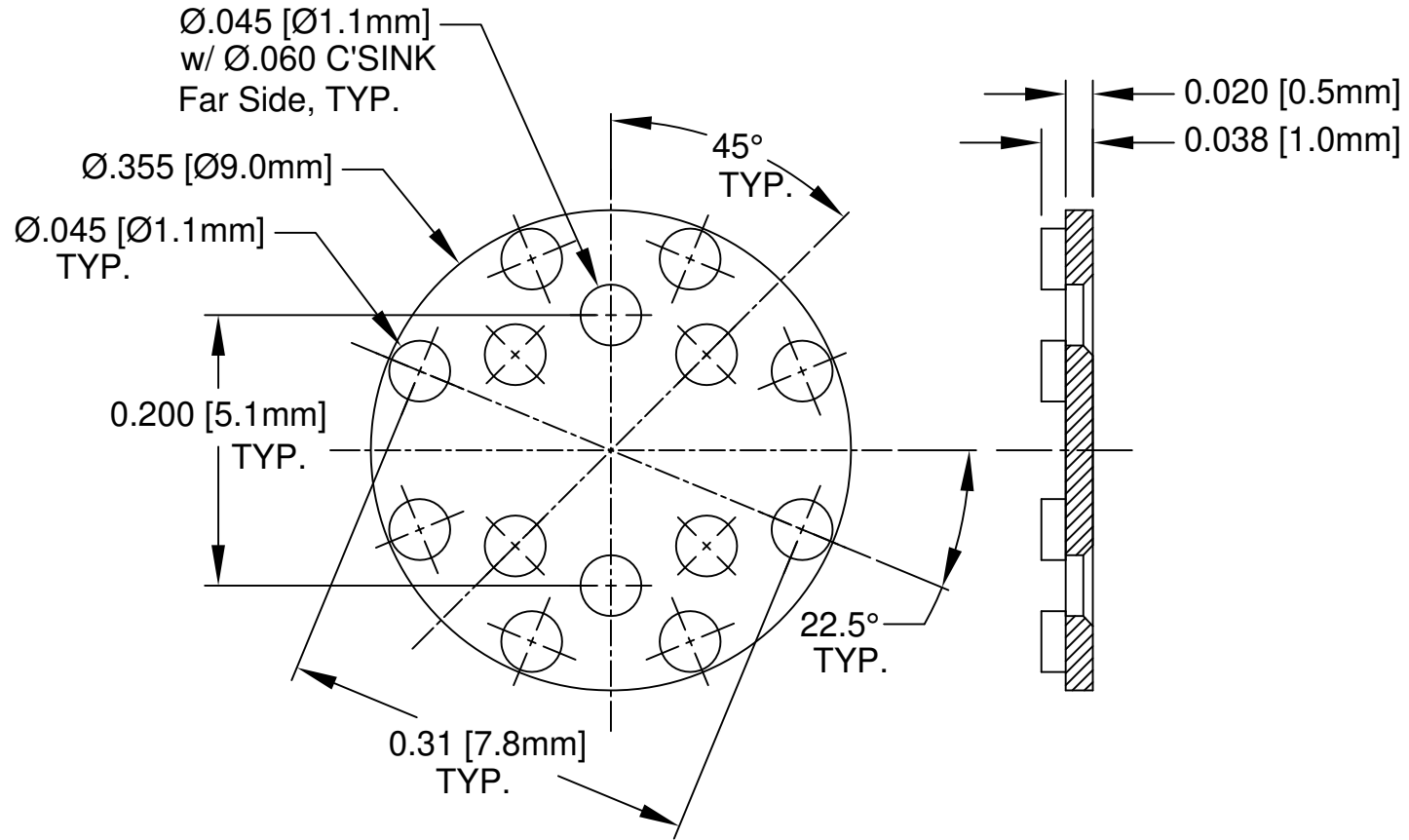

2. MATERIAL: NYLON 6/6, 94V-2, WHITE.

1. GENERAL SPECIFICATIONS: BIVAR MOLDED COMPONENT SPECIFICATION BV00-E101.

STANDARD TOLERANCE (UNLESS OTHERWISE SPECIFIED)		BIVAR [®]	
DECIMALS	ANGULAR	4 THOMAS, IRVINE, CA. 92618	
.X ±.1	X° ±1°	TEL: (949) 951-8808 FAX: (949) 951-3974	
.XX ±.01		TITLE: PERM-O-PAD TO-5 AND IC MOUNT	
.XXX ±.005		PART NO: 602-038	
DESIGNED: T. Yin	DATE: 02/23/04	REVISION: B	
CHECKED: D. Green	DATE: 02/23/04	CAGE CODE : 32559	SHEET # 1 OF 1
CAD GENERATED DOCUMENT. DO NOT MEASURE DRAWING.			