

- 1. POST TO WITHSTAND 13 NEWTONS (3LBS.) MIN. AXIAL FORCE IN BOTH DIRECTIONS SHOWN WITHOUT DISLODGING.
- 2. TOLERANCES APPLY TO SOLDER SIDE OF BOARD.
- 3. MEASURED AT SURFACE $\overline{-A-}$
- 4. PLASTIC FLASH PERMITTED IN THIS AREA.
- 5. PARTS COMPLY WITH AMP SOLDERABILITY SPEC. NO. 109-11-2.
- 6. ONE HOLE MAY BE UNDERSIZED (.035/.032 DIA.) FOR ASSEMBLY RETENTION DURING WAVE SOLDERING.
- 7. MATERIAL: HEADER-THERMOPLASTIC POLYESTER 94V-0(NATURAL) POST-COPPER ALLOY (TIN PLATED)
- 8. COORDINATE DIMENSION APPLIES FROM CENTER OF ACTUAL FEATURE.
- 9. PLASTIC BURRS CAUSED BY CUT-OFF TOOLING ARE PERMITTED WITHIN THE MAXIMUM TOLERANCE ENVELOPE.
- 10. POST TO BE MEASURED WHEN STRIP IS HELD FLAT.
- 11. POST MUST WITHSTAND TWO 90° BENDS AGAINST EXTRUSION WITHOUT BREAKING.
- 12. DIMENSION SHOULD BE .130 MIN WHEN MATING WITH A MTA 100 CONNECTOR ASSEMBLY OR WHEN MATING WITH A CST 100 CONNECTOR.
- 13. PIN BURR OF .005 MAX VERTICAL AND .003 MAX HORIZONTAL PERMITTED AT POST TIPS ON BOTH ENDS.
- 14. COLOR STRIPE GREEN IN APPROXIMATE LOCATION SHOWN FOR 644830-1. COLOR STRIPE ORANGE IN APPROXIMATE LOCATION SHOWN FOR 644830-2.

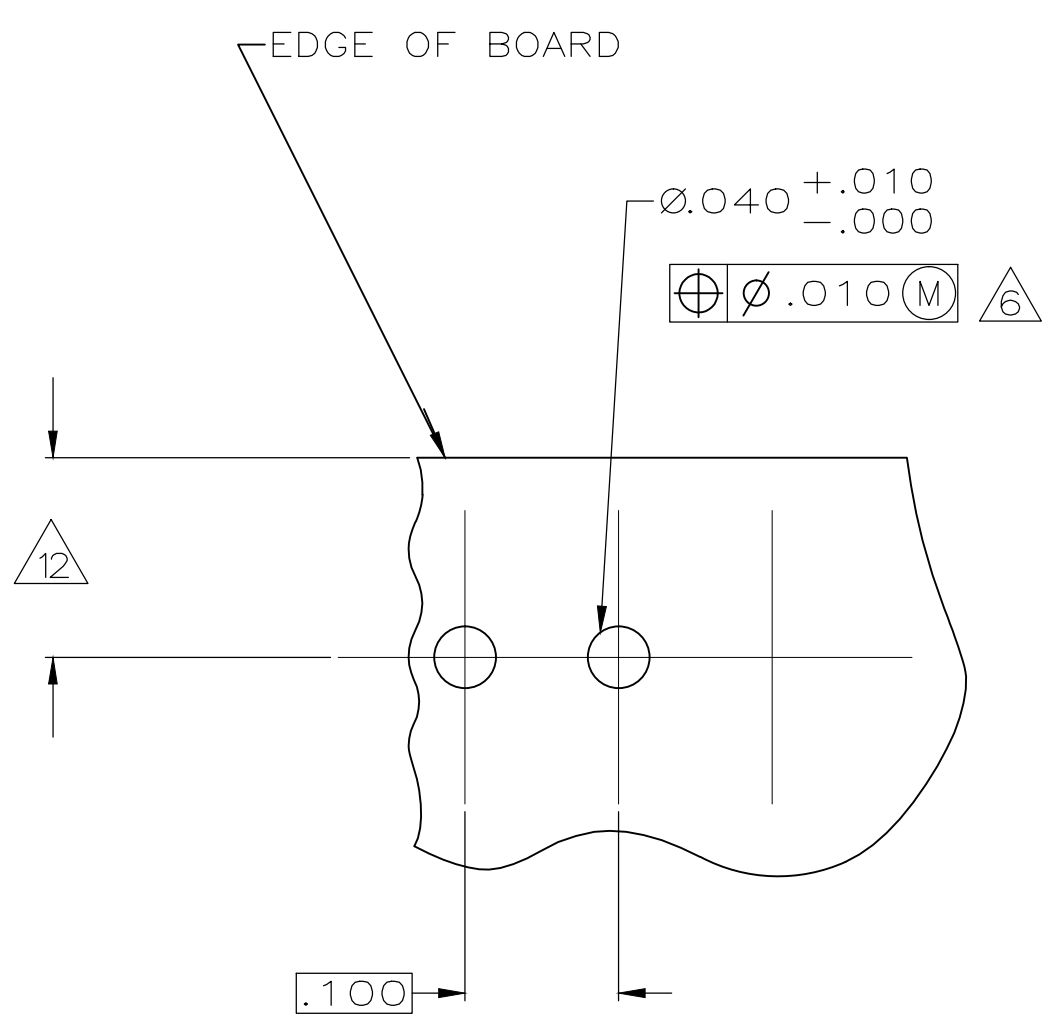

RECOMMENDED MOUNTING HOLE PATTERN FOR .063 THICK P.C. BOARD

IN	MM	IN	MM
.050	1.27	-	-
.040	1.02	-	-
.035	0.89	.535	13.59
.032	0.81	.310	7.87
.030	0.76	.300	7.62
.025	0.64	.295	7.49
.020	0.51	.225	5.72
.015	0.38	.150	3.81
.010	0.25	.140	3.56
.008	0.20	.130	3.30
.005	0.13	.125	3.18
.003	0.08	.100	2.54
.001	0.03	.063	1.60
IN	MM	IN	MM

CONVERSION TABLE

644830-1 SHOWN

2	644830-2
1	644830-1
POST NO. OMITTED	PART NO
STE TE Connectivity	
NAME: MTA-100 HEADER ASSEMBLY, FRICTION LOCK, NOTCHED, .025 SQUARE STRAIGHT POST, TIN PLATED.	
SIZE: A1	WEIGHT: -
CAGE CODE: 00779	DRAWING NO: 644830
CUSTOMER DRAWING	SCALE: 8:1 SHEET 1 OF 1 REV B1

THIS DRAWING IS A CONTROLLED DOCUMENT.

DIMENSIONS: INCHES

TOLERANCES UNLESS OTHERWISE SPECIFIED:

0. PLC	±	-
1. PLC	±	-
2. PLC	±	-
3. PLC	±	.005
4. PLC	±	.005

ANGLES: ± 0° 30'

MATERIAL: 7

FINISH: 7

