

**CONFIGURATION SHOWN
HOLD DOWN TYPE**

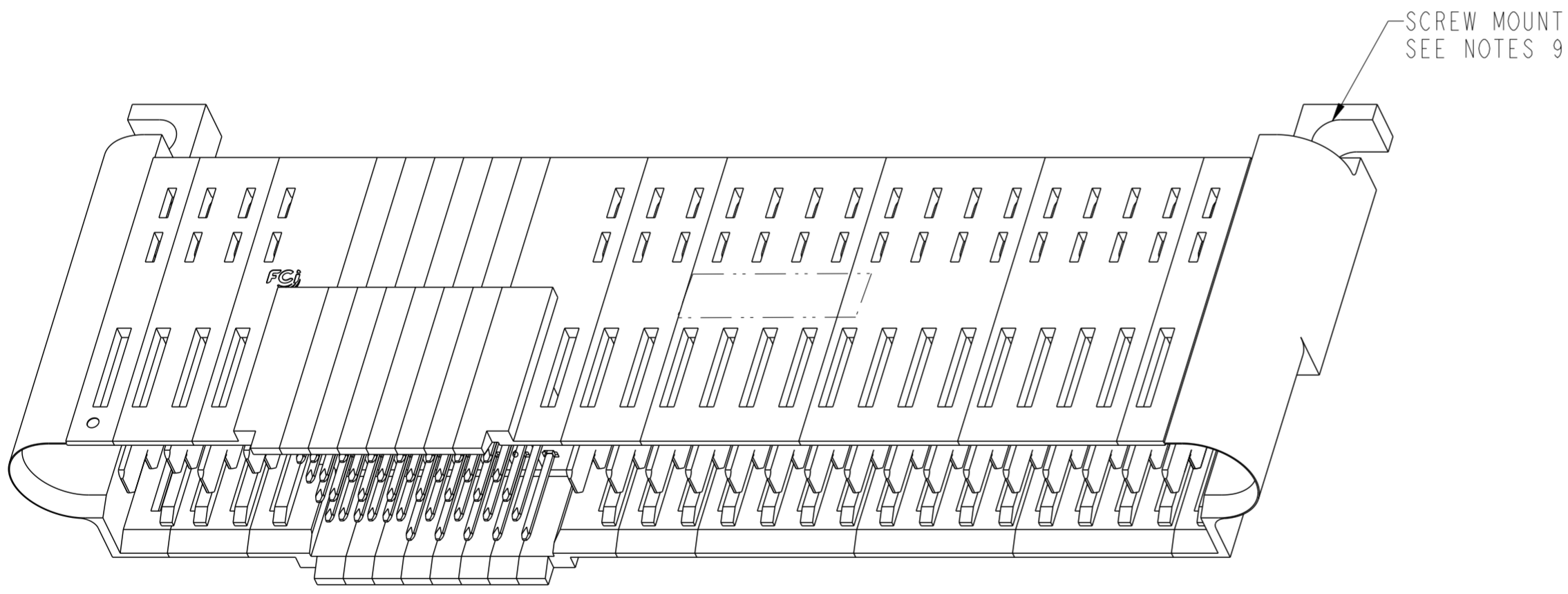

**CONFIGURATION SHOWN
SCREW MOUNT TYPE**

NOTES:

1. HOUSING MATERIAL: GF LCP, COLOR: BLACK, UL 94 V-0 RATED
SIGNAL CONTACT MATERIAL: PHOSPHOR BRONZE
SIGNAL PIN OVERMOLD MATERIAL: GF POLYESTER
POWER CONTACT MATERIAL: COPPER ALLOY
2. PLATING ON SIGNAL CONTACTS: 1.27µm MIN Ni UNDERPLATING ALL OVER WITH 0.76µm MIN GXT IN CONTACT MATING AREA, AND 0.5µm MIN MATTE TIN ON TAIL AREA.

PLATING ON POWER CONTACTS: 1.27µm MIN Ni UNDERPLATING ALL OVER WITH 0.76µm MIN GXT IN CONTACT MATING AREA, AND 0.5µm MIN MATTE TIN ON TAIL AREA.

PLATING ON HOLD DOWN IF APPLICABLE: 1.27µm MIN Ni, UNDERPLATING ALL OVER WITH 0.76µm MIN MATTE TIN OVER.
3. LUBRICATION: LUBRICATE ON CONTACT AREA.
4. RECOMMENDED PCB THICKNESS IS:
FOR PRESS FIT APPLICATION: 1.4mm MIN
FOR SOLDER APPLICATION: 1.40mm THROUGH 2.62mm.
5. FOR SCREW MOUNT APPLICATIONS, A #4-40 UNC PAN SCREW WITH HEX NUT IS RECOMMENDED (SUPPLIED BY CUSTOMER).
6. FOR PRESS FIT $\varnothing 0.61 \pm 0.05\text{mm}$, FOR SOLDER $\varnothing 0.90 \pm 0.05\text{mm}$.
7. UNPLATED HOLES.
8. HOLD DOWN APPLICATION NEEDED.
9. SCREW MOUNT APPLICATION NEEDED.
10. PRODUCT SPECIFICATION: GS-12-1064
APPLICATION SPECIFICATION: GS-20-0362

Copyright FCI. FCI

spec ref	SEE NOTE	dr	Eddy Zeng	2014/07/16	projection	MM	size	A2	scale	3:1																	
tolerance std	TOLERANCES UNLESS OTHERWISE SPECIFIED	eng	Eddy Zeng	2014/09/04			ecn no	-	rel level	Released																	
ASME Y14.5		chr	Li-He	2014/09/04																							
		appr	Pei-Ming Zheng	2014/09/04	product family	PwrLoPro																					
surface	<table border="1"> <tr> <td>linear</td> <td>0.X</td> <td>±0.30</td> </tr> <tr> <td></td> <td>0.XX</td> <td>±0.20</td> </tr> <tr> <td></td> <td>0.XXX</td> <td>±0.10</td> </tr> <tr> <td>angular</td> <td>0°</td> <td>±2°</td> </tr> </table>	linear	0.X	±0.30		0.XX	±0.20		0.XXX	±0.10	angular	0°	±2°		<table border="1"> <tr> <td>title</td> <td>PWR LoPro HEADER ASSEMBLY</td> <td>dwg no</td> <td>10130991</td> <td>rev</td> <td>A</td> </tr> <tr> <td>RA, PASSIVE GUIDE, P+S+P</td> <td></td> <td></td> <td></td> <td></td> <td></td> </tr> </table>	title	PWR LoPro HEADER ASSEMBLY	dwg no	10130991	rev	A	RA, PASSIVE GUIDE, P+S+P					
linear	0.X	±0.30																									
	0.XX	±0.20																									
	0.XXX	±0.10																									
angular	0°	±2°																									
title	PWR LoPro HEADER ASSEMBLY	dwg no	10130991	rev	A																						
RA, PASSIVE GUIDE, P+S+P																											
ASME Y14.5		www.fci.com	cat. no.	-	Product - Customer Drw	sheet 1 of 7																					

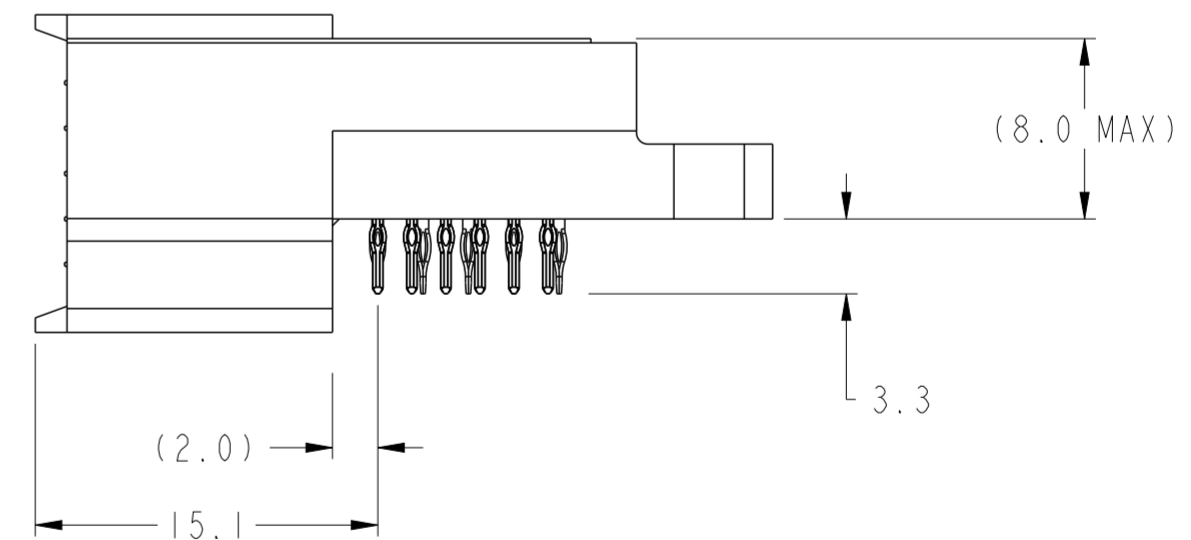
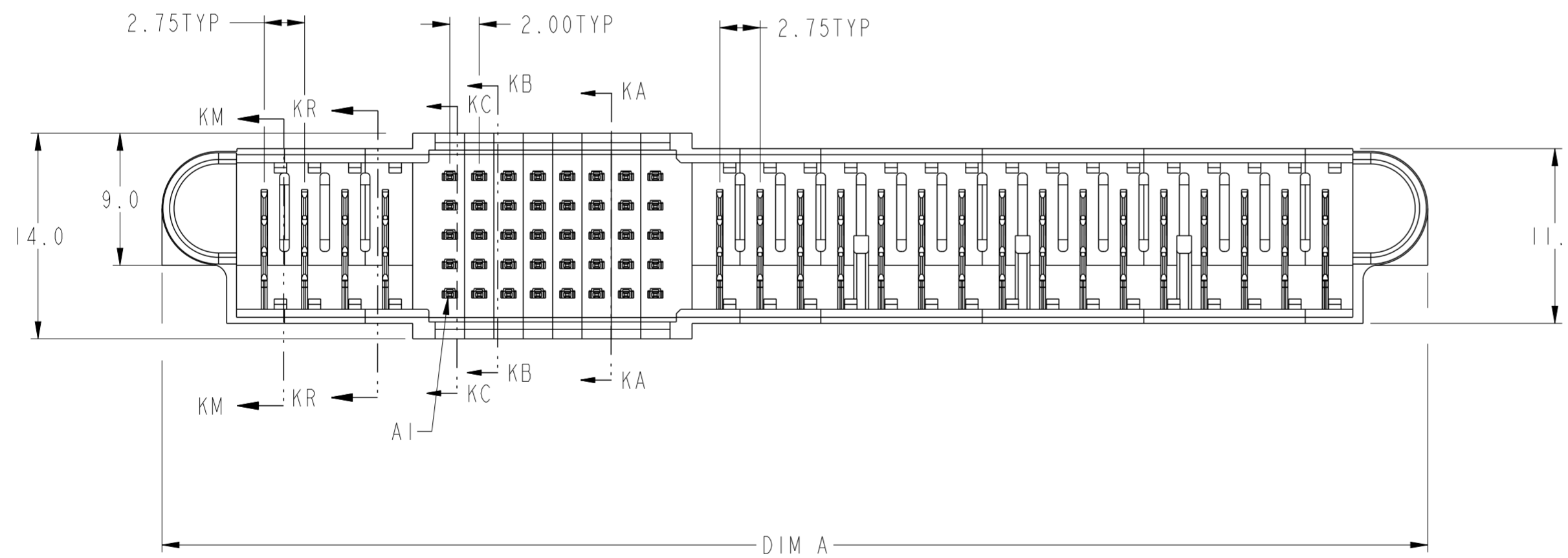
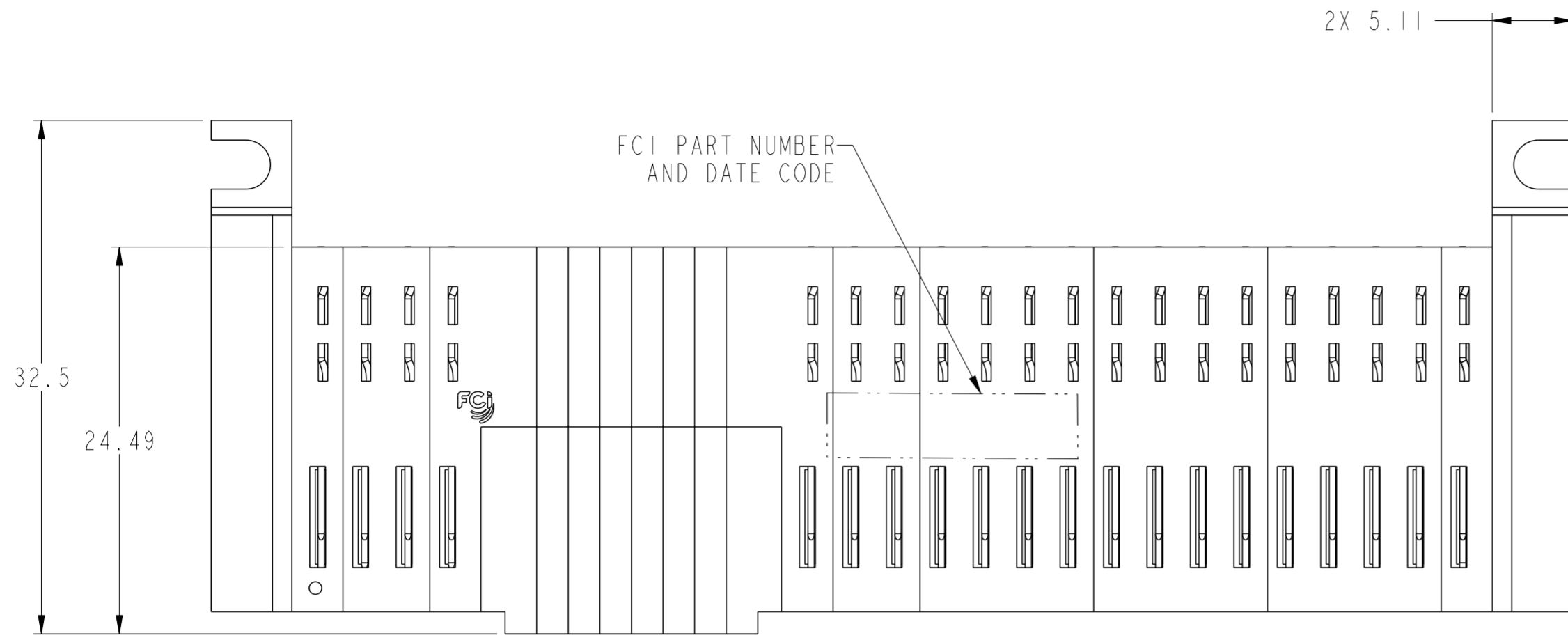

SCREW MOUNT TYPE AS SHOWN

spec ref	SEE NOTE	dr	Eddy Zeng	2014/07/16	projection	MM	size	A2	scale	3:1
tolerance std	ASME Y14.5	eng	Eddy Zeng	2014/09/04			ecn no	-	rel level	Released
	TOLERANCES UNLESS OTHERWISE SPECIFIED	chr	Li-He	2014/09/04						
surface	✓	appr	Pai-Ming Zheng	2014/09/04	product family	PwrLoPro	rel level	Released	rev	A
ASME Y14.5	linear	0.X	±0.30		title PWR LoPro HEADER ASSEMBLY RA, PASSIVE GUIDE,P+S+P	cat. no. -	Product - Customer Drw	sheet 2 of 7	rev A	A
		0.XX	±0.20							
	angular	0°	±2°							

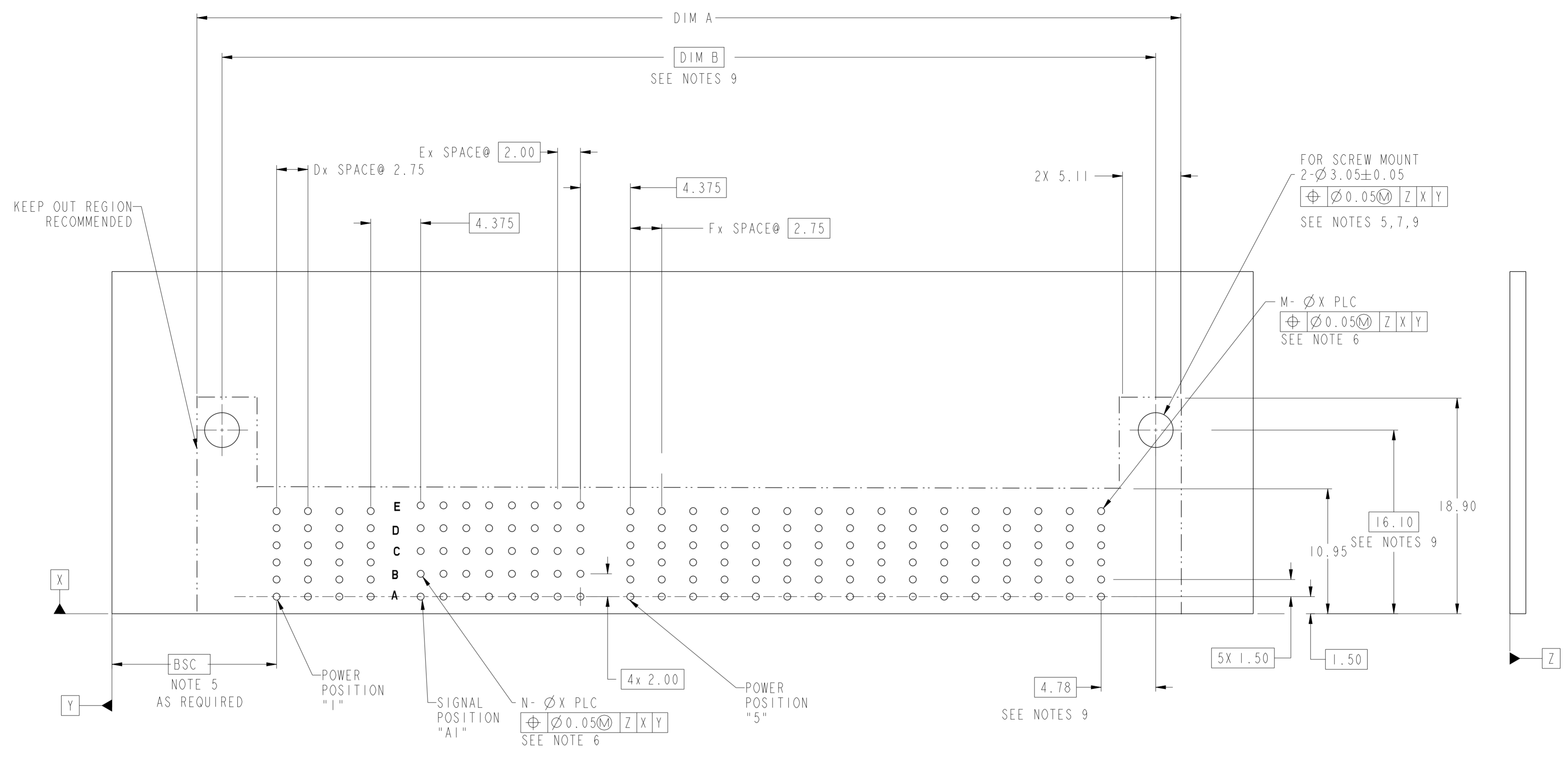

10130991-XXXLF AS SHOWN
 RECOMMENDED PRINTED CIRCUIT BOARD LAYOUT SEE NOTE 4
 FOR 10130991-XXXLF SCREW MOUNT TYPE
 (AS VIEWED FROM COMPONENT SIDE)

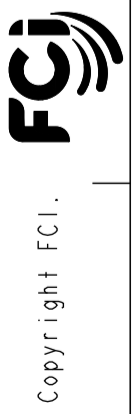

spec ref	SEE NOTE	dr	Eddy Zeng	2014/07/18	projection	MM	size	A2	scale	5:1	
tolerance std	ASME Y14.5	eng	Eddy Zeng	2014/09/04		PwrLoPro	ecn no	-	rel level	Released	
	TOLERANCES UNLESS OTHERWISE SPECIFIED	chr	Li-He	2014/09/04			product family	PwrLoPro		rel level	Released
surface	linear	appr	Pai-Ming Zheng	2014/09/04			title	PWR LoPro HEADER ASSEMBLY	cat. no.	10130991	
	angular						RA, PASSIVE GUIDE, P+S+P	Product - Customer Drw	sheet 3 of 7	rev	A

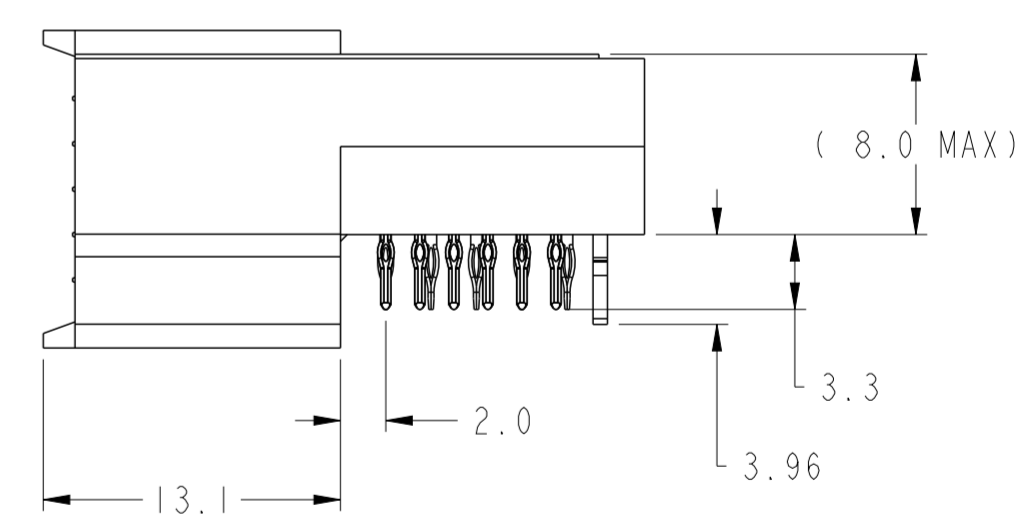
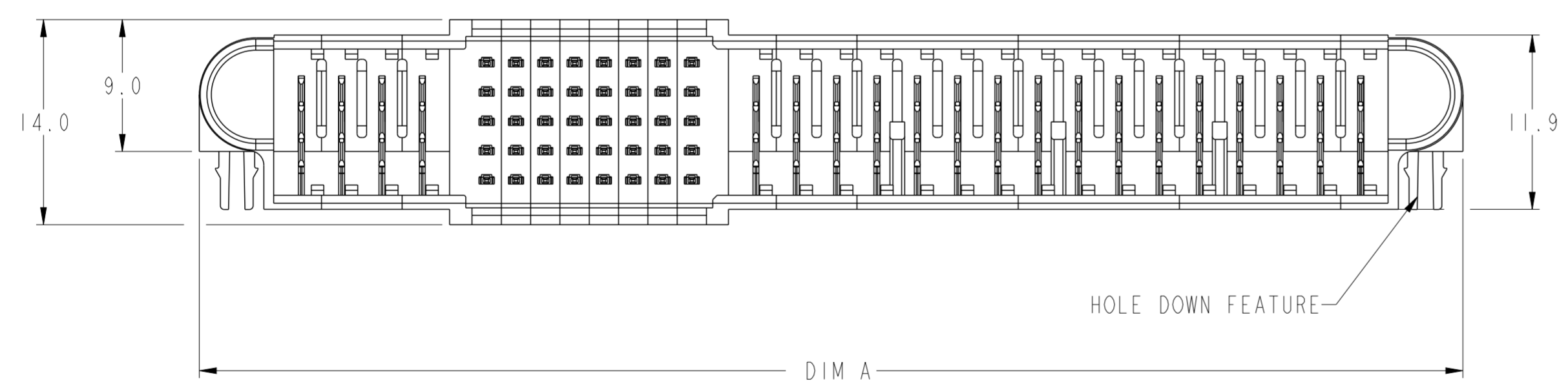
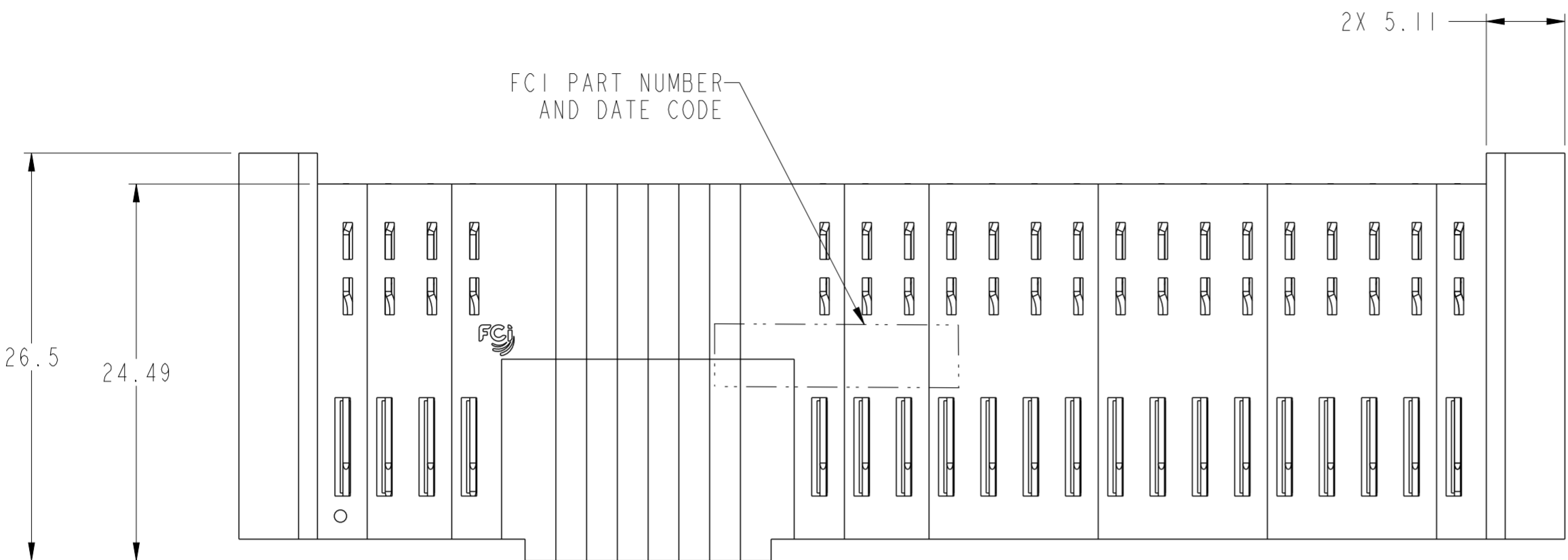

HOLE DOWN TYPE AS SHOWN

spec ref	SEE NOTE	dr	Eddy Zeng	2014/07/16	projection	MM	size	A2	scale	1:1
tolerance std	ASME Y14.5	eng	Eddy Zeng	2014/09/04			ecn no	-	rel level	Released
TOLERANCES UNLESS OTHERWISE SPECIFIED		chr	Li-He	2014/09/04						
		appr	Pai-Ming Zheng	2014/09/04						
surface	✓	linear	0.X	±0.30	product family	PwrLoPro	rel level	Released	title	PWR LoPro HEADER ASSEMBLY
			0.XX	±0.20	cat. no.	-	Product - Customer Drw	sheet 4 of 7	dwg no	10130991
			0.XXX	±0.10	www.fci.com				rev	A
		angular	0°	±2°						

PDS: Rev :A

STATUS:Released

Printed: Sep 05, 2014

Copyright FCI.

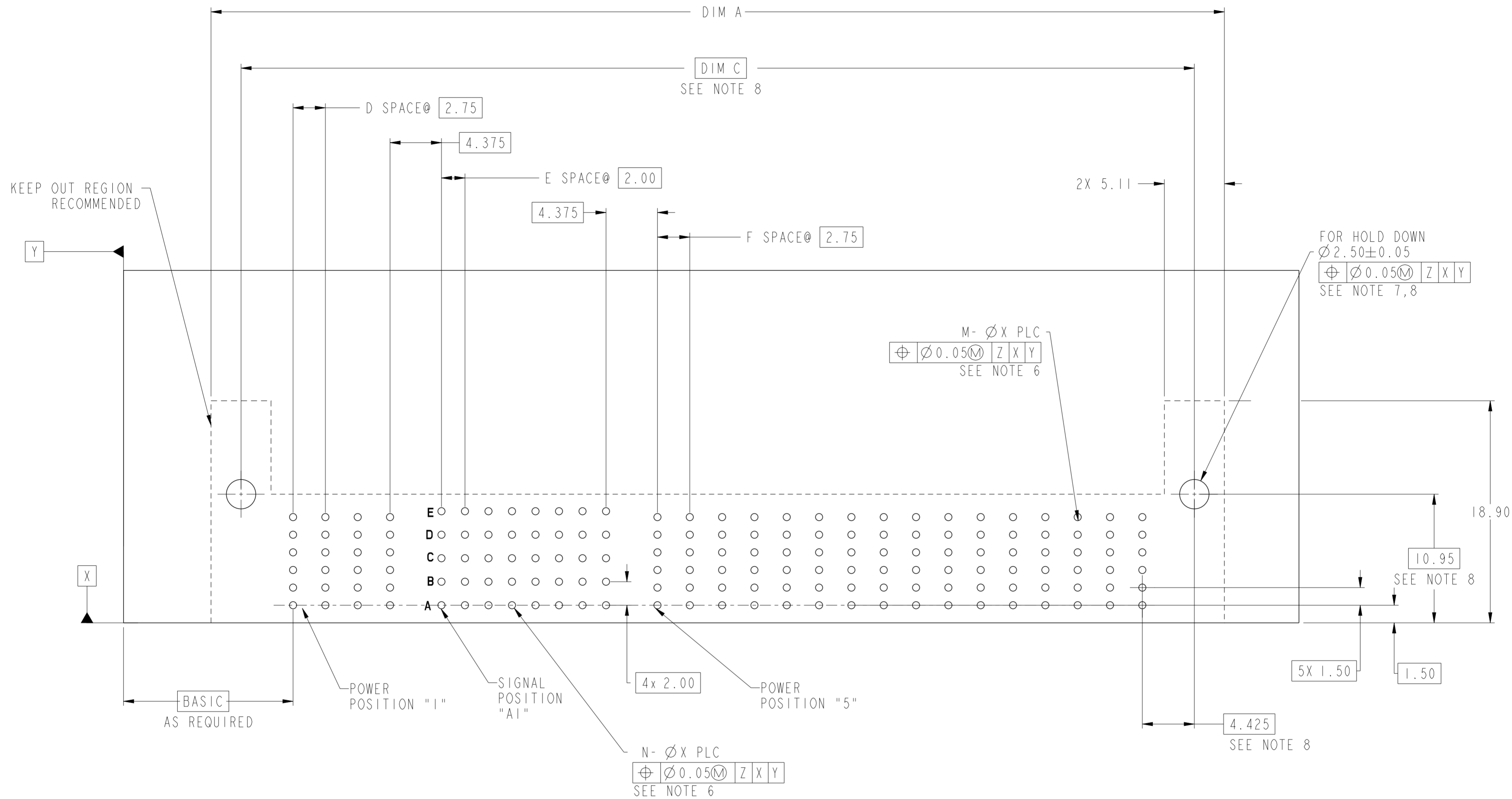

10130991-001LF AS SHOWN
RECOMMENDED PRINTED CIRCUIT BOARD LAYOUT SEE NOTE 4
FOR 10130991-XXXLF HOLD DOWN TYPE
 (AS VIEWED FROM COMPONENT SIDE)

spec ref	SEE NOTE	dr	Eddy Zeng	2014/07/16	projection	MM	size	A2	scale	1:1
tolerance std	ASME Y14.5	eng	Eddy Zeng	2014/09/04			ecn no	-	rel level	Released
TOLERANCES UNLESS OTHERWISE SPECIFIED		chr	Li-He	2014/09/04						
		appr	Pei-Ming Zheng	2014/09/04						
surface	ASME Y14.5	linear	0.X	±0.30	product family	PwrLoPro	rel level	Released	title	PWR LoPro HEADER ASSEMBLY
			0.XX	±0.20	cat. no.	-	Product - Customer Drw	sheet 5 of 7	rev	A
		angular	0°	±2°						





Copyright FCI.

PART NUMBER	CONFIGURATION	DIM "A"	DIM "B" FOR SCREW MOUNT	DIM "C" FOR HOLD DOWN	"D" SPACES	"E" SPACES	"F" SPACES	"M" QTY.	"N" QTY.	MOUNTING FEATURE
10130991-001LF	4P+40S+16P	86.21	-	81.10	3	7	15	120	40	HOLD DOWN

PART NUMBER	ROWS	POWERS				SIGNALS								POWERS															
		1	2	3	4	1	2	3	4	5	6	7	8	5	6	7	8	9	10	11	12		13	14	15	16	17	18	19
10130991-001LF 4P+40S+16P	E	-	-	2	2	32222	32222	32222	32222	32222	32222	32222	32222	-	-	-	-	-	-	-	-	-	-	-	-	-	-	-	-
	D																												
	C																												
	B																												
	A																												

VIEWED FROM MATING FACE:

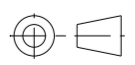
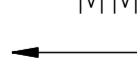
CODE	DESCRIPTION
1	FOR LEVEL 1
2	FOR LEVEL 2
32222	FOR LEVEL 32222 (MIXED)
3	FOR LEVEL 3

spec ref	SEE NOTE	dr	Eddy Zeng	2014/07/16	projection	MM	size	A2	scale	1:1											
tolerance std	ASME Y14.5	eng	Eddy Zeng	2014/09/04			ecn no	-	rel level												
TOLERANCES UNLESS OTHERWISE SPECIFIED		chr	Li-He	2014/09/04			product family	PwrLoPro	Released												
surface	<table border="1"> <tr> <td>linear</td> <td>0.X</td> <td>±0.30</td> </tr> <tr> <td></td> <td>0.XX</td> <td>±0.20</td> </tr> <tr> <td></td> <td>0.XXX</td> <td>±0.10</td> </tr> <tr> <td>angular</td> <td>0°</td> <td>±2°</td> </tr> </table>	linear	0.X	±0.30				0.XX	±0.20		0.XXX	±0.10	angular	0°	±2°	appr	Pai-Ming Zheng	2014/09/04	www.fci.com	cat. no.	-
linear	0.X	±0.30																			
	0.XX	±0.20																			
	0.XXX	±0.10																			
angular	0°	±2°																			
				title PWR LoPro HEADER ASSEMBLY RA, PASSIVE GUIDE,P+S+P		dwg no 10130991	rev A														

Copyright FCI. FCI

CUSTOMER LOADING WORKSHEET FOR SIGNAL & POWER SEQUENCING LEVELS

PWR LO PRO - MATING FACE OF HEADER CONNECTOR(4)

E	X																									X										
D																																				
C																																				
B																																				
A																																				
ROWS	MOUNTING FEATURE(3)	1	2	3	4	5	6	1	2	3	4	5	6	7	8	7	8	9	10	11	12	13	14	15	16	17	18	19	20	21	22	23	24	25	26	MOUNTING FEATURE(3)
		POWER CONTACTS						SIGNAL CONTACTS								POWER CONTACTS																				

- 1). LOAD WITH CHOICE OF 2 POWER CONTACT MATING LEVELS, SEE SECTIONS KM & KR FOR AVAILABLE LEVEL OPTIONS.
- 2). LOAD WITH CHOICE OF 3 SIGNAL CONTACT MATING LEVELS, SEE SECTIONS KA,KB,&KC FOR AVAILABLE LEVEL OPTIONS.
- 3). MOUNTING FEATURE OPTION "X"
 - H : HOLD DOWN TYPE
 - S : SCREW MOUNT TYPE
- 4). CUSTOMER LOADING WORKSHEET SHOWN AT MAXMUM SIZE CONFIGURATION (40Sx24P), SIGNALS AVAILABLE IN 2,3,4 THRU 8 POSITIONS, POWERS AVAILABLE IN 4,6,8 THRU 24 POSITIONS IN EVEN QUANTITIES ONLY.

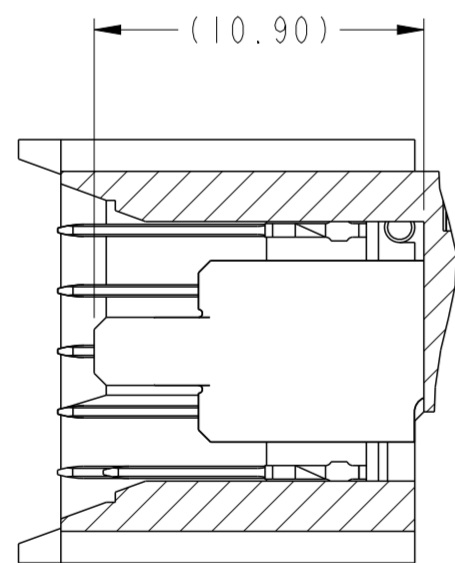

POWER SECTION KM-KM LEVEL 1: LONGEST MATING CONTACTS

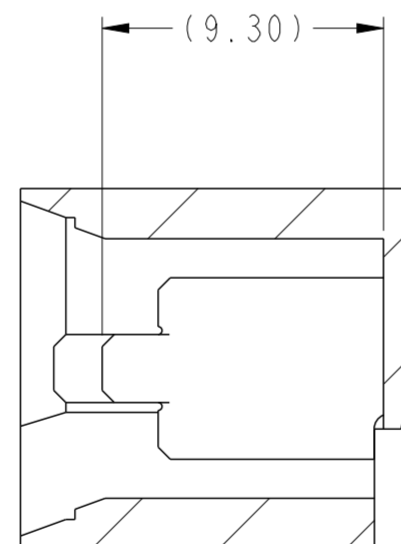

POWER SECTION KR-KR LEVEL 2: SHORTEST MATING CONTACTS

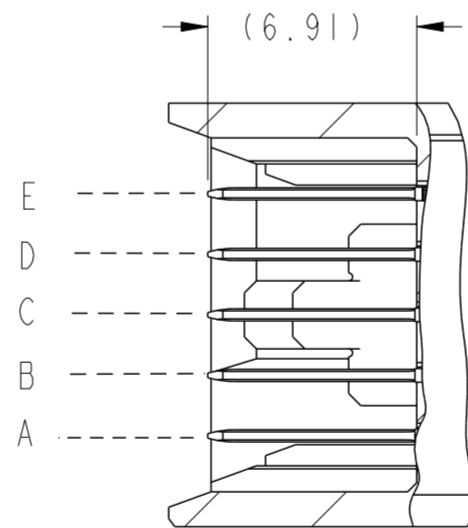

SIGNAL SECTION KA-KA LEVEL 2: ALL LONGEST CONTACTS

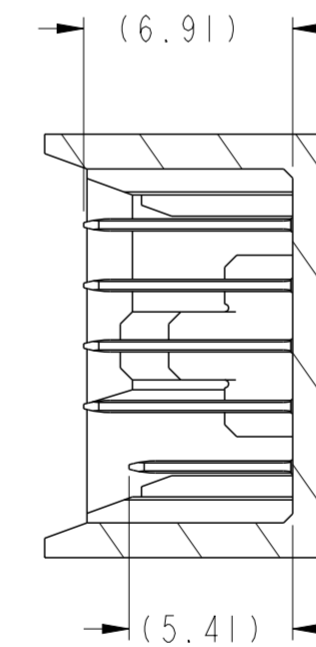

SIGNAL SECTION KB-KB LEVEL 3222 (MIXED): ROW "A", SHORTEST CONTACT ROW "B" THRU "E", LONGEST CONTACTS

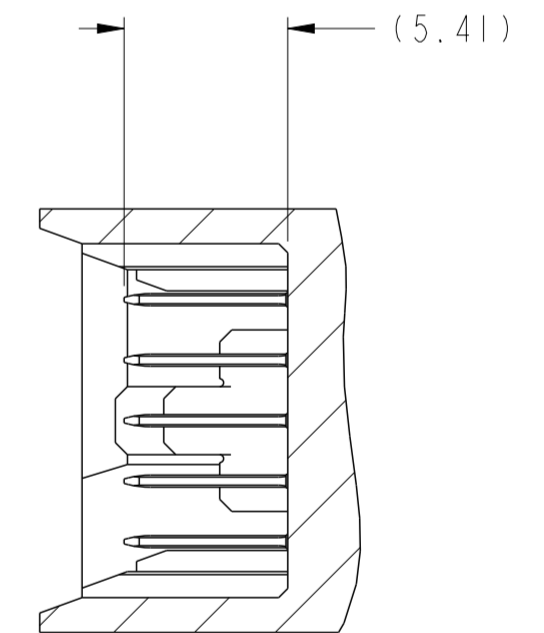

SIGNAL SECTION KC-KC LEVEL 3: ALL SHORTEST CONTACTS

spec ref	SEE NOTE	dr	Eddy Zeng	2014/07/18	projection	MM	size	A2	scale	1:1											
tolerance std	ASME Y14.5	eng	Eddy Zeng	2014/09/04			ecn no	-	rel level	Released											
	TOLERANCES UNLESS OTHERWISE SPECIFIED	chr	Li-He	2014/09/04																	
		appr	Pai-Ming Zheng	2014/09/04																	
surface	<table border="1"> <tr> <td>linear</td> <td>0.X</td> <td>±0.30</td> </tr> <tr> <td></td> <td>0.XX</td> <td>±0.20</td> </tr> <tr> <td></td> <td>0.XXX</td> <td>±0.10</td> </tr> <tr> <td>angular</td> <td>0°</td> <td>±2°</td> </tr> </table>	linear	0.X	±0.30		0.XX	±0.20		0.XXX	±0.10	angular	0°	±2°			product family	PwrLoPro	cat. no.	-	Product - Customer Drw	sheet 7 of 7
linear	0.X	±0.30																			
	0.XX	±0.20																			
	0.XXX	±0.10																			
angular	0°	±2°																			
ASME Y14.5		title	PWR LoPro HEADER ASSEMBLY			RA, PASSIVE GUIDE,P+S+P	dwg no	10130991	rev	A											