

DM74LS109A Dual Positive-Edge-Triggered J-K Flip-Flops with Preset, Clear, and Complementary Outputs

General Description

This device contains two independent positive-edge-triggered J-K flip-flops with complementary outputs. The J and \bar{K} data is accepted by the flip-flop on the rising edge of the clock pulse. The triggering occurs at a voltage level and is not directly related to the transition time of the rising edge of the clock. The data on the J and \bar{K} inputs may be changed while the clock is high or low as long as

setup and hold times are not violated. A low logic level on the preset or clear inputs will set or reset the outputs regardless of the logic levels of the other inputs.

Features

- Alternate Military/Aerospace device (54LS109) is available. Contact a Fairchild Semiconductor Sales Office/Distributor for specifications

Connection Diagram

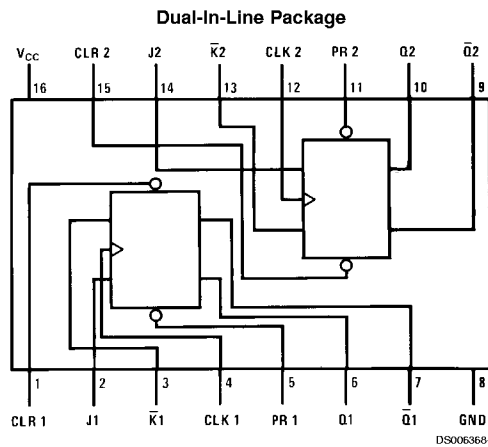

Order Number 54LS109DMQB, 54LS109FMQB, DM54LS109AJ,
DM54LS109AW, DM74LS109AM or DM74LS109AN
See Package Number J16A, M16A, N16E or W16A

Function Table

Inputs					Outputs	
PR	CLR	CLK	J	\bar{K}	Q	\bar{Q}
L	H	X	X	X	H	L
H	L	X	X	X	L	H
L	L	X	X	X	H (Note 1)	H (Note 1)
H	H	↑	L	L	L	H
H	H	↑	H	L	Toggle	
H	H	↑	L	H	Q_0	\bar{Q}_0
H	H	↑	H	H	H	L
H	H	L	X	X	Q_0	\bar{Q}_0

H = High Logic Level
L = Low Logic Level
X = Either Low or High Logic Level
↑ = Rising Edge of Pulse

Q_0 = The output logic level of Q before the indicated input conditions were established.

Toggle = Each output changes to the complement of its previous level on each active transition of the clock pulse.

Note 1: This configuration is nonstable; that is, it will not persist when preset and/or clear inputs return to their inactive (high) state.

Absolute Maximum Ratings (Note 2)

Supply Voltage	7V	DM54LS and 54LS	-55°C to +125°C
Input Voltage	7V	DM74LS	0°C to +70°C
Operating Free Air Temperature Range		Storage Temperature Range	-65°C to +150°C

Recommended Operating Conditions

Symbol	Parameter	DM54LS109A			DM74LS109A			Units
		Min	Nom	Max	Min	Nom	Max	
V _{CC}	Supply Voltage	4.5	5	5.5	4.75	5	5.25	V
V _{IH}	High Level Input Voltage	2			2			V
V _{IL}	Low Level Input Voltage			0.7			0.8	V
I _{OH}	High Level Output Current			-0.4			-0.4	mA
I _{OL}	Low Level Output Current			4			8	mA
f _{CLK}	Clock Frequency (Note 4)	0		25	0		25	MHz
f _{CLK}	Clock Frequency (Note 5)	0		20	0		20	MHz
t _w	Pulse Width (Note 4)	Clock High	18		18			ns
		Preset Low	15		15			
		Clear Low	15		15			
t _w	Pulse Width (Note 5)	Clock High	25		25			ns
		Preset Low	20		20			
		Clear Low	20		20			
t _{SU}	Setup Time (Notes 3, 4)	Data High	30↑		30↑			ns
		Data Low	20↑		20↑			
t _{SU}	Setup Time (Notes 3, 5)	Data High	35↑		35↑			ns
		Data Low	25↑		25↑			
t _H	Hold Time (Note 6)	0↑			0↑			ns
T _A	Free Air Operating Temperature	-55		125	0		70	°C

Note 2: The "Absolute Maximum Ratings" are those values beyond which the safety of the device cannot be guaranteed. The device should not be operated at these limits. The parametric values defined in the "Electrical Characteristics" table are not guaranteed at the absolute maximum ratings. The "Recommended Operating Conditions" table will define the conditions for actual device operation.

Note 3: The symbol (↑) indicates the rising edge of the clock pulse is used for reference.

Note 4: C_L = 15 pF, R_L = 2 kΩ, T_A = 25°C and V_{CC} = 5V.

Note 5: C_L = 50 pF, R_L = 2 kΩ, T_A = 25°C and V_{CC} = 5V.

Note 6: T_A = 25°C and V_{CC} = 5V.

Electrical Characteristics

over recommended operating free air temperature range (unless otherwise noted)

Symbol	Parameter	Conditions	Min	Typ (Note 7)	Max	Units
V _I	Input Clamp Voltage	V _{CC} = Min, I _I = -18 mA			-1.5	V
V _{OH}	High Level Output Voltage	V _{CC} = Min, I _{OH} = Max	DM54	2.5	3.4	V
		V _{IL} = Max, V _{IH} = Min	DM74	2.7	3.4	
V _{OL}	Low Level Output Voltage	V _{CC} = Min, I _{OL} = Max	DM54	0.25	0.4	V
		V _{IL} = Max, V _{IH} = Min	DM74	0.35	0.5	
		I _{OL} = 4 mA, V _{CC} = Min	DM74	0.25	0.4	
I _I	Input Current @ Max Input Voltage	V _{CC} = Max V _I = 7V	J, \bar{K}		0.1	mA
			Clock		0.1	
			Preset		0.2	
			Clear		0.2	

Electrical Characteristics (Continued)

over recommended operating free air temperature range (unless otherwise noted)

Symbol	Parameter	Conditions	Min	Typ (Note 7)	Max	Units
I_{IH}	High Level Input Current	$V_{CC} = \text{Max}$ $V_I = 2.7V$	J, \bar{K}		20	μA
			Clock		20	
			Preset		40	
			Clear		40	
I_{IL}	Low Level Input Current	$V_{CC} = \text{Max}$ $V_I = 0.4V$	J, \bar{K}		-0.4	mA
			Clock		-0.4	
			Preset		-0.8	
			Clear		-0.8	
I_{OS}	Short Circuit Output Current	$V_{CC} = \text{Max}$ (Note 8)	DM54	-20	-100	mA
			DM74	-20	-100	
I_{CC}	Supply Current	$V_{CC} = \text{Max}$ (Note 9)		4	8	mA

Switching Characteristics

at $V_{CC} = 5V$ and $T_A = 25^\circ\text{C}$

Symbol	Parameter	From (Input) To (Output)	$R_L = 2\text{ k}\Omega$				Units
			$C_L = 15\text{ pF}$		$C_L = 50\text{ pF}$		
			Min	Max	Min	Max	
f_{MAX}	Maximum Clock Frequency		25		20		MHz
t_{PLH}	Propagation Delay Time Low to High Level Output	Clock to Q or \bar{Q}		25		35	ns
t_{PHL}	Propagation Delay Time High to Low Level Output	Clock to Q or \bar{Q}		30		35	ns
t_{PLH}	Propagation Delay Time Low to High Level Output	Clear to \bar{Q}		25		35	ns
t_{PHL}	Propagation Delay Time High to Low Level Output	Clear to Q		30		35	ns
t_{PLH}	Propagation Delay Time Low to High Level Output	Preset to Q		25		35	ns
t_{PHL}	Propagation Delay Time High to Low Level Output	Preset to \bar{Q}		30		35	ns

Note 7: All typicals are at $V_{CC} = 5V$, $T_A = 25^\circ\text{C}$.

Note 8: Not more than one output should be shorted at a time, and the duration should not exceed one second. For devices, with feedback from the outputs, where shorting the outputs to ground may cause the outputs to change logic state an equivalent test may be performed where $V_O = 2.25V$ and $2.125V$ for DM54 and DM74 series, respectively, with the minimum and maximum limits reduced by one half from their stated values. This is very useful when using automatic test equipment.

Note 9: I_{CC} is measured with all outputs open, with CLOCK grounded after setting the Q and \bar{Q} outputs high in turn.

Physical Dimensions inches (millimeters) unless otherwise noted

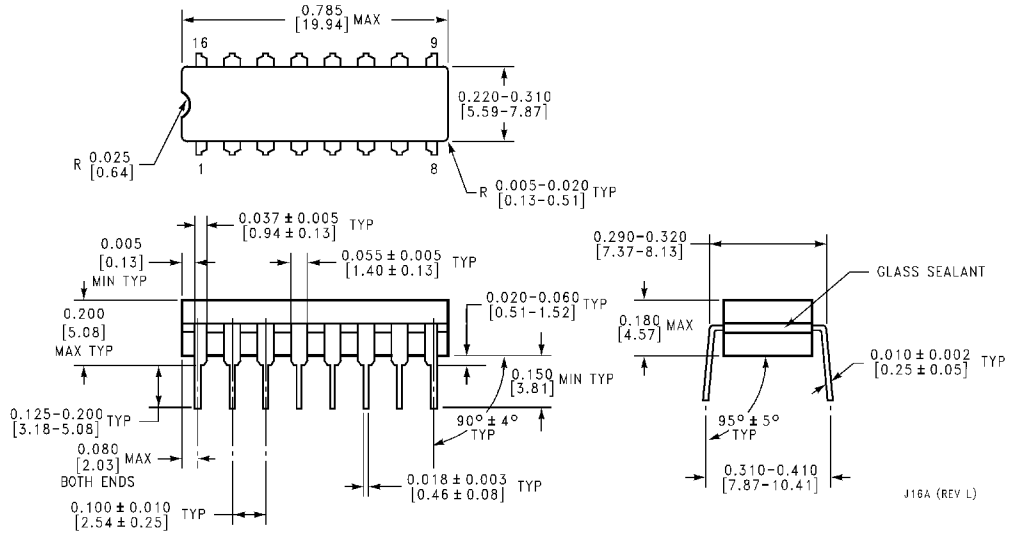

16-Lead Ceramic Dual-In-Line Package (J)
Order Number 54LS109DMQB or DM54LS109AJ
Package Number J16A

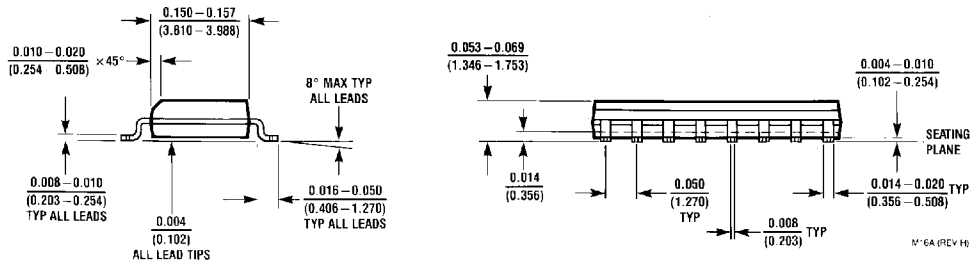
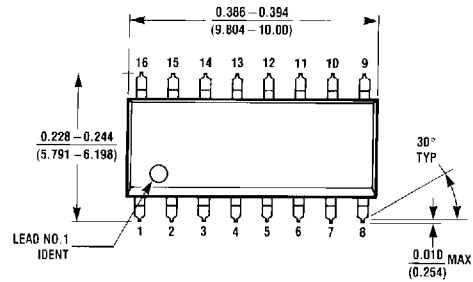

16-Lead Small Outline Molded Package (M)
Order Number DM74LS109AM
Package Number M16A

Physical Dimensions inches (millimeters) unless otherwise noted (Continued)

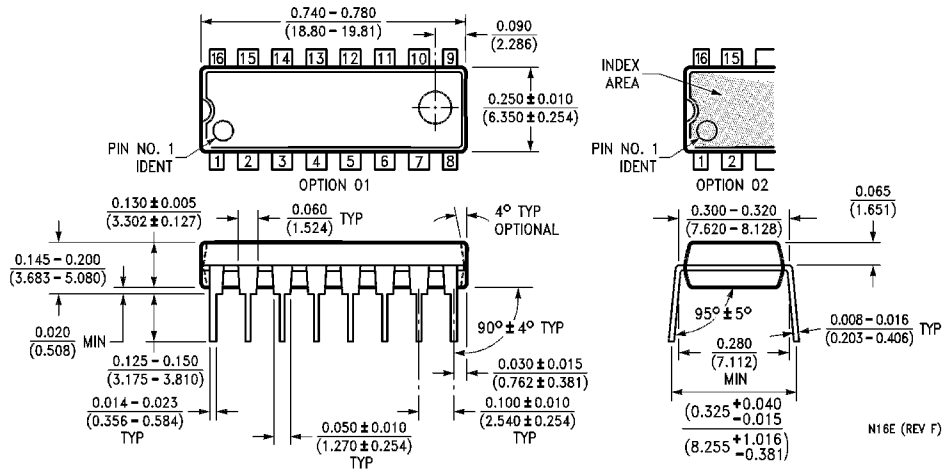

16-Lead Molded Dual-In-Line Package (N)
Order Number DM74LS109AN
Package Number N16E

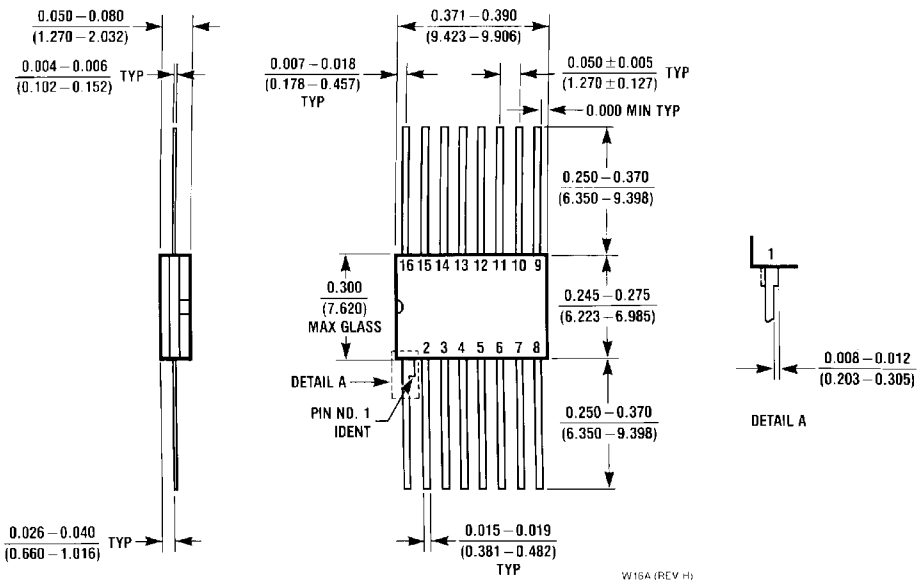

16-Lead Ceramic Flat Package
Order Number 54LS109FMQB or DM54LS109AW
Package Number W16A