



### Electrical specifications

**Center Frequency:** 2 MHz  
**Bandwidth:** 0.20 MHz  
**Passband:** 1.95-2.05 MHz  
**Insertion Loss:** 6.0 dB Max  
**Return Loss:** 14 dB Min  
**Rejection:** >50 dB @ 0-1.78 MHz  
>50 dB @ 2.22-50 MHz

### Mechanical

**Dimensions:** 4.0 x 1.25 x 0.75 inches

### Environmental

**Operating Temperature:** -45 to +85o C  
**Storage Temperature:** -55 to +95o C  
**Shock:** 20 G. 11ms  
**Vibration:** 20 G. 5 to 200 MHz

### Outline Drawing:

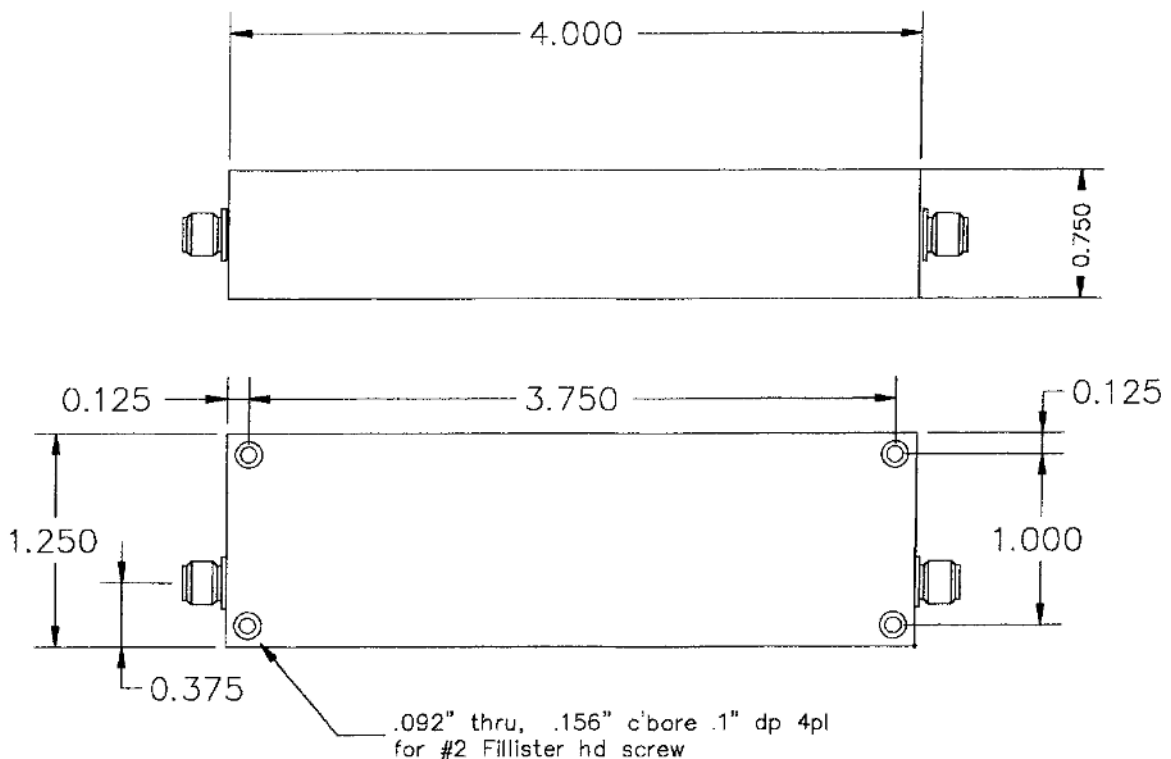



## 2 MHz LC Bandpass Filter

Part Number: AE2B8807



### Plot:

