

- NOTES: 1. MATERIAL:  
 HOUSING: POLYESTER, G.F. (UL 94V-0), COLOUR - BLACK.  
 TERMINAL: PHOSPHOR BRONZE.
2. TERMINAL PLATING:  
 90635-\*\*\*1: CONTACT AREA: GOLD FLASH 0.1µm MIN.  
 I.D. AREA: TIN 1µm MIN. OVER  
 NICKEL 1µm MIN.  
 90635-\*\*\*2: CONTACT AREA: GOLD 0.76µm MIN.  
 I.D. AREA: TIN 1µm MIN. OVER  
 NICKEL 1µm MIN.  
 90635-\*\*\*3: CONTACT AREA: GOLD 0.38µm MIN.  
 I.D. AREA: TIN 1µm MIN. OVER  
 NICKEL 1µm MIN.
3. FOR USE WITH NO. 26 & 28 AWG STRANDED WIRE (7 CONDUCTORS)  
 AND NO. 28 SOLID WIRE 1.14 DIA. MAX. INSULATION RIBBON  
 CABLE WITH 1.27 CENTERS.
4. MATING STRAIN RELIEF: MOLEX NO. 90170.
5. DIMENSION "E" IS TOTAL HEIGHT AFTER ASSEMBLED WITH CABLE.  
 E= 10.5 REF. WITHOUT STRAIN RELIEF.  
 E= 15.2 MAX. WITH STRAIN RELIEF NO. 90170.  
 14.5 REF. WHEN COMPRESSED.
6. FOR PRODUCT SPECIFICATION, SEE PS: 99020-0015.

64	90635-064*	78.74	82.54	85.88	83.31
60	90635-060*	73.66	77.46	80.80	78.23
50	90635-050*	60.96	64.76	68.10	65.53
40	90635-040*	48.26	52.06	55.40	52.83
34	90635-034*	40.64	44.44	47.78	45.21
30	90635-030*	35.56	39.36	42.70	40.13
26	90635-026*	30.48	34.28	37.62	35.05
24	90635-024*	27.94	31.74	35.08	32.51
20	90635-020*	22.86	26.66	30.00	27.43
16	90635-016*	17.78	21.58	24.92	22.35
14	90635-014*	15.24	19.04	22.38	19.81
10	90635-010*	10.16	13.96	17.30	14.73
NO. OF CKT.	ENG. NO.	A	B	C REF.	D

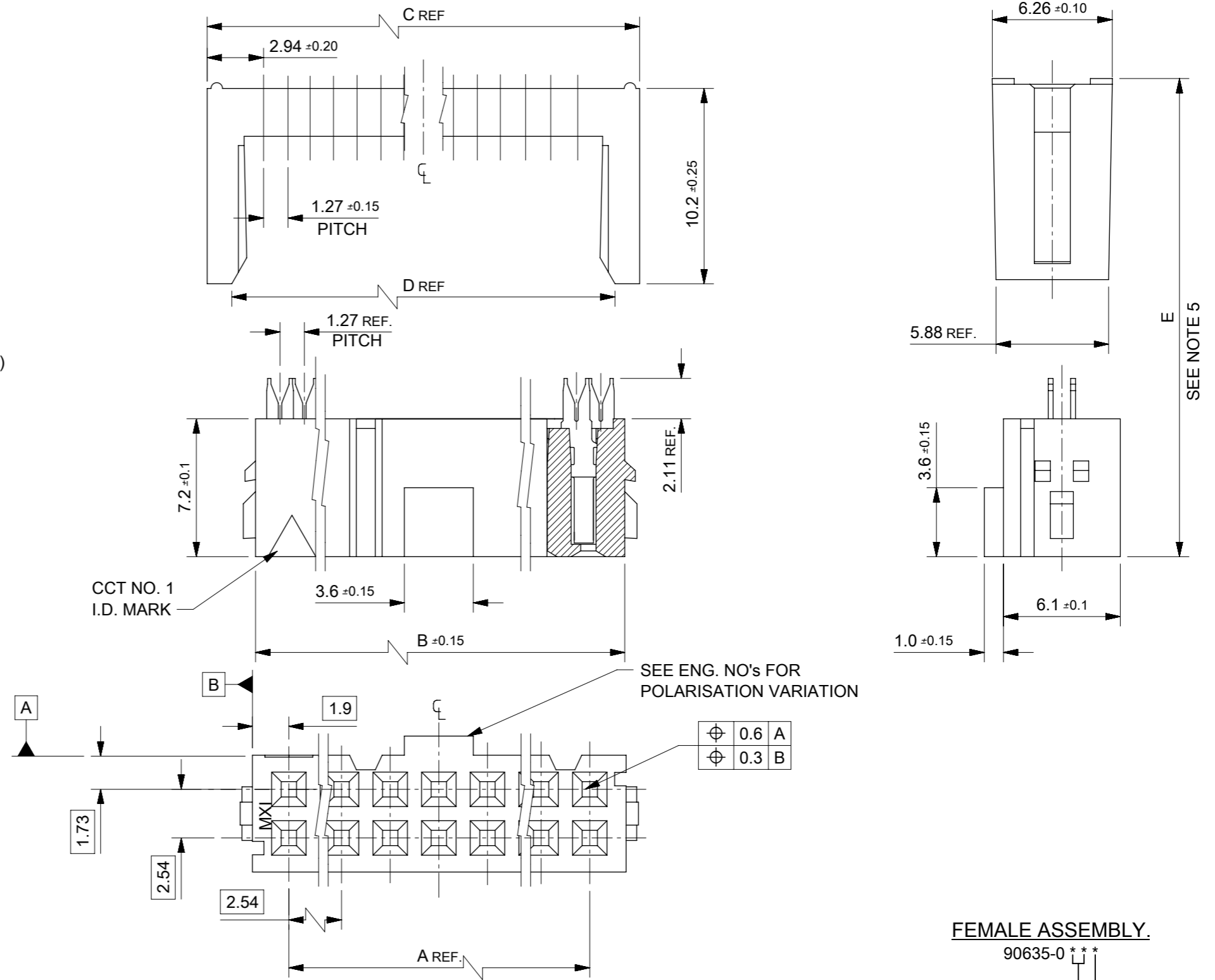

THIS DRAWING CONTAINS INFORMATION THAT IS PROPRIETARY TO MOLEX ELECTRONIC TECHNOLOGIES, LLC AND SHOULD NOT BE USED WITHOUT WRITTEN PERMISSION		CURRENT REV DESC: CAD MIGRATION		<b>molex</b>	
DIMENSION UNITS	SCALE				
mm	4:1			QIK FLECS SINGLE BEAM FEMALE ASSEMBLY	
GENERAL TOLERANCES (UNLESS SPECIFIED)				PRODUCT CUSTOMER DRAWING	
ANGULAR TOL	± °			DOCUMENT NUMBER	
4 PLACES	±	EC NO: 619136		SDA-90635	
3 PLACES	±	DRWN: EEGBEDIRE 2018/10/04		DOC TYPE	DOC PART
2 PLACES	±	CHK'D: TTOURISH 2019/04/15		PSD	001
1 PLACE	±	APPR: DMAHER 2019/04/15		REVISION	E
0 PLACES	±	INITIAL REVISION:		SHEET NUMBER	
DRAFT WHERE APPLICABLE MUST REMAIN WITHIN DIMENSIONS		THIRD ANGLE PROJECTION	DRAWING	SERIES	MATERIAL NUMBER
			A3-SIZE	90635	SEE CHART
				CUSTOMER	GENERAL MARKET
					1 OF 2

- NOTES: 1. MATERIAL:  
 HOUSING: POLYESTER, G.F. (UL 94V-0), COLOUR - BLACK.  
 TERMINAL: PHOSPHOR BRONZE.
2. TERMINAL PLATING:  
 90635-\*\*\*1: CONTACT AREA: GOLD FLASH 0.1µm MIN.  
 I.D. AREA: TIN 1µm MIN. OVER  
 NICKEL 1µm MIN.  
 90635-\*\*\*2: CONTACT AREA: GOLD 0.76µm MIN.  
 I.D. AREA: TIN 1µm MIN. OVER  
 NICKEL 1µm MIN.  
 90635-\*\*\*3: CONTACT AREA: GOLD 0.38µm MIN.  
 I.D. AREA: TIN 1µm MIN. OVER  
 NICKEL 1µm MIN.
3. FOR USE WITH NO. 26 & 28 AWG STRANDED WIRE (7 CONDUCTORS)  
 AND NO. 28 SOLID WIRE 1.14 DIA. MAX. INSULATION RIBBON  
 CABLE WITH 1.27 CENTERS.
4. MATING STRAIN RELIEF: MOLEX NO. 90170.
5. DIMENSION "E" IS TOTAL HEIGHT AFTER ASSEMBLED WITH CABLE.  
 E= 10.5 REF. WITHOUT STRAIN RELIEF.  
 E= 15.2 MAX. WITH STRAIN RELIEF NO. 90170.  
 14.5 REF. WHEN COMPRESSED.
6. FOR PRODUCT SPECIFICATION, SEE PS: 99020-0015.

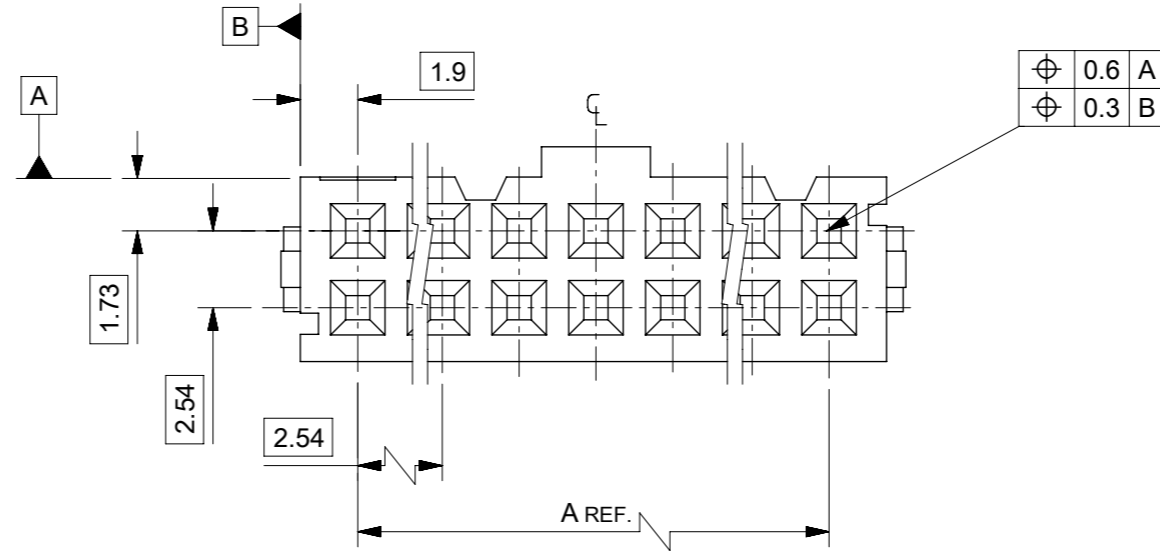
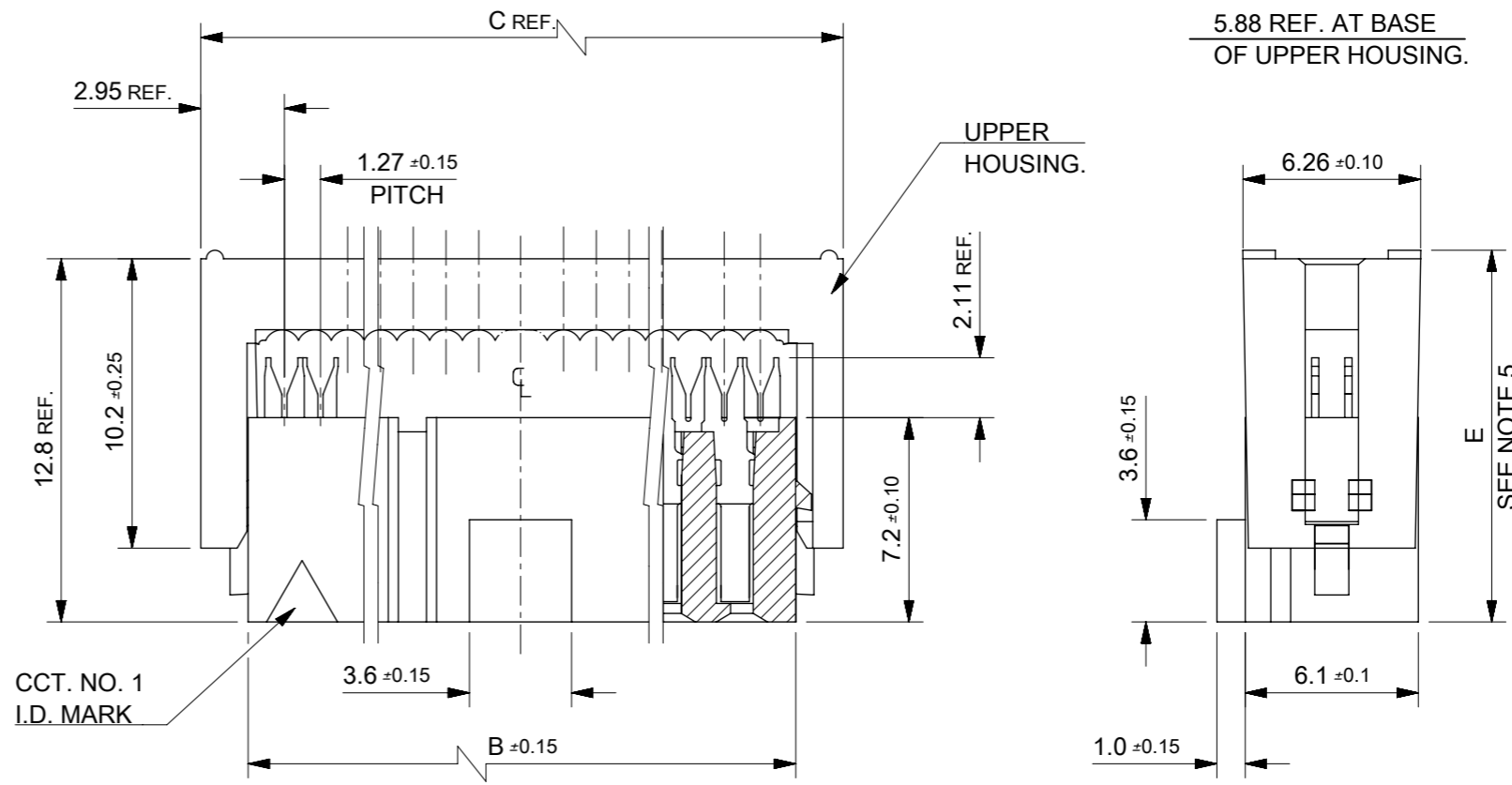

**FEMALE ASSEMBLY.**  
**PRE-LOADED.**  
 90635-1 \*\*\*  
 PLATING OPTION  
 CIRCUIT SIZE

64	90635-164*	78.74	82.54	85.88
60	90635-160*	73.66	77.46	80.80
50	90635-150*	60.96	64.76	68.10
40	90635-140*	48.26	52.06	55.40
34	90635-134*	40.64	44.44	47.78
30	90635-130*	35.56	39.36	42.70
26	90635-126*	30.48	34.28	37.62
24	90635-124*	27.94	31.74	35.08
20	90635-120*	22.86	26.66	30.00
16	90635-116*	17.78	21.58	24.92
14	90635-114*	15.24	19.04	22.38
10	90635-110*	10.16	13.96	17.30
NO. OF CKT.	ENG. NO.	A	B	C REF

DIMENSION UNITS		SCALE	CURRENT REV DESC: CAD MIGRATION					
mm		4:1	<b>molex</b> QIK FLECS SINGLE BEAM FEMALE ASSEMBLY PRE-LOADED PRODUCT CUSTOMER DRAWING					
GENERAL TOLERANCES (UNLESS SPECIFIED)								
ANGULAR TOL	±	°						
4 PLACES	±							
3 PLACES	±							
2 PLACES	±							
1 PLACE	±		EC NO: 619136 DRWN: EEGBEDIRE 2018/10/04 CHK'D: TTOURISH 2019/04/15 APPR: DMAHER 2019/04/15					
0 PLACES	±		INITIAL REVISION: DRWN: POB 1990/09/25 APPR: JDENNEHY 2005/08/10					
DRAFT WHERE APPLICABLE MUST REMAIN WITHIN DIMENSIONS			THIRD ANGLE PROJECTION	DRAWING	SERIES	MATERIAL NUMBER	CUSTOMER	SHEET NUMBER
				A3-SIZE	90635	SEE CHART	GENERAL MARKET	2 OF 2