

APPROVED: \_\_\_\_\_  
 DATE: \_\_\_\_\_ TITLE: \_\_\_\_\_

Rev	AWO #	Description	Date	Appr
-		RELEASED	11/2/20	
A		UPDATE SPEC.	8/31/21	JJ/RC
B		UPDATE DIM	5/27/22	WX/MC

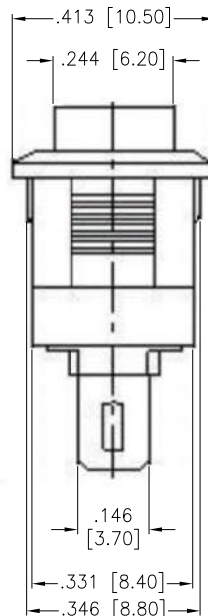
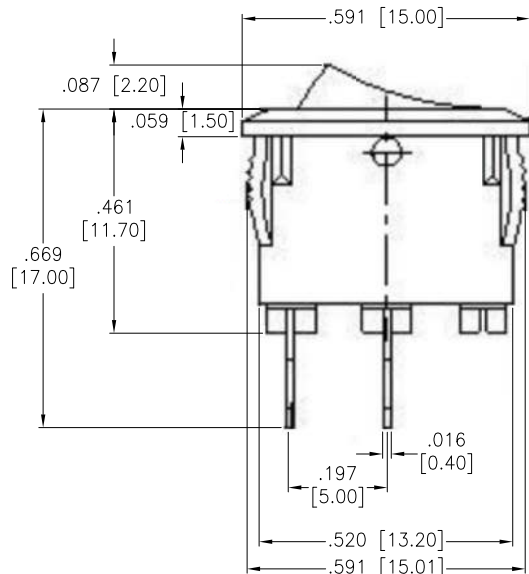
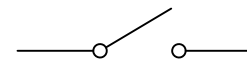
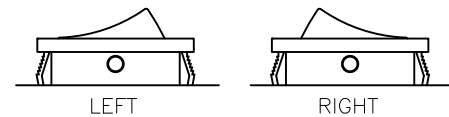
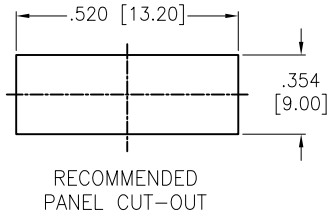
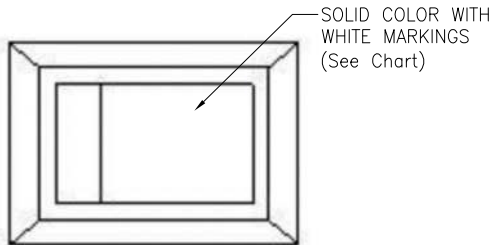

SW-R3-1A-A-XX-0

	Actuator Color
BLANK	Standard Black
W	White
R	Red

	Actuator Markings
1	
2	
3	
4	
5	

**SPECIFICATIONS:**

Body: Nylon 66, Color Black, Rated UL 94V-0

Terminal: Brass, Silver plated

Button: Nylon 66, Solid color, White color markings. (See Chart)

**Electrical:**

The rated load: 250V AC, 3A  
 125V AC, 6A

Contact resistance: 50 mohms max

Insulation resistance: 100 Mohms min

Dielectric withstanding voltage: 1500 VAC/5S min

**Mechanical:**

Electrical life: 10000 Cycles min

Temperature Rating:

Operating temperature: -25°C to +85°C

**Environmental:**

Lead free, RoHS compliant



Replace "x" in P/N with the corresponding switch color and marking

UNLESS OTHERWISE SPECIFIED ALL DIMENSIONS ARE INCHES [MM]. TOLERANCES: EXCEPT AS NOTED

INCHES		HOLES	
.X	± .10	∅X	± .10
.XX	± .020	∅XX	± .015
.XXX	± .015	∅XXX	± .010



909 Rahway Avenue,  
 Union, NJ 07083  
 Phone: 908-687-5000  
 Fax: 908-687-5710

DRAWN	OW	11/2/20
CHECKED	AC	11/2/20
APPROVED		

TITLE SWITCH, SUB MINIATURE ROCKER, SPST, ON-OFF, SOLDER TYPE

THIS DRAWING CONTAINS INFORMATION THAT IS PROPRIETARY AND SHOULD NOT BE USED WITHOUT PRIOR WRITTEN PERMISSION FROM ADAM TECH

SIZE X	PART NO. SW-R3-1A-A-XX-0	REV. B
REF: S00206C	SCALE: NTS	SHEET 1 OF 1