

FUNCTION	PART NUMBER	MATERIAL / FINISH	PACKAGING			
			TAPE AND REEL			
FENCE	BMI-S-202-F	.20MM 1008/1010 PRE-PLATED COLD ROLLED STEEL 1/2 HARD 1.25-5.00 MICRONS 100% MATTE TIN	REEL DIAMETER	TAPE WIDTH	PITCH	QUANTITY
			380MM	32MM	24MM	700
COVER	BMI-S-202-C	.13MM 1008/1010 PRE-PLATED COLD ROLLED STEEL 1/2 HARD 1.25-5.00 MICRONS 100% MATTE TIN	BULK PACK			

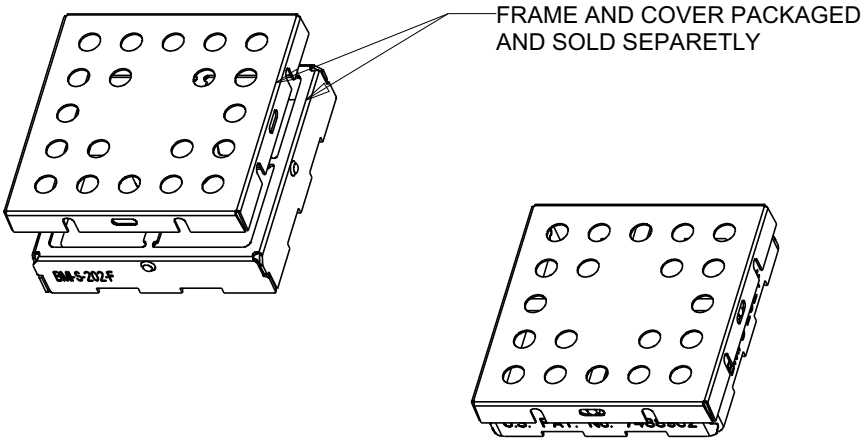

- NOTES:
- OTHER MATERIAL OPTIONS MAY BE AVAILABLE, CONSULT SALES.
  - OTHER PACKAGING OPTIONS MAY BE AVAILABLE, CONSULT SALES.

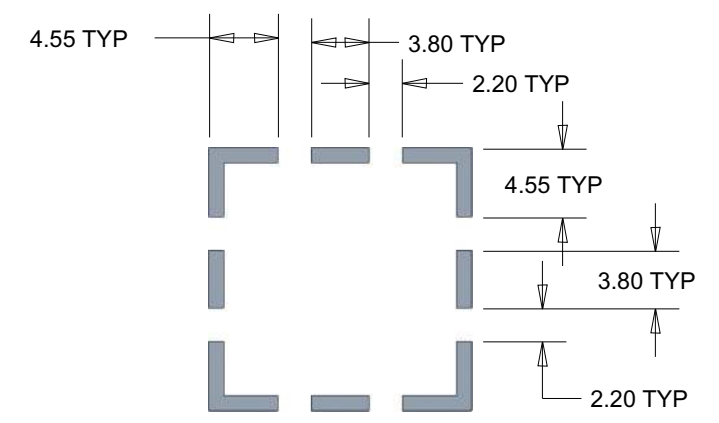
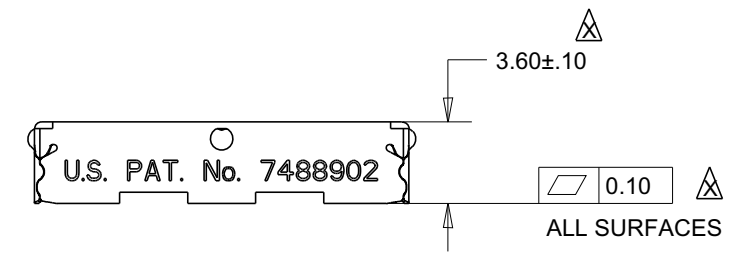
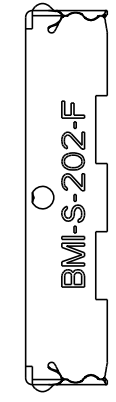
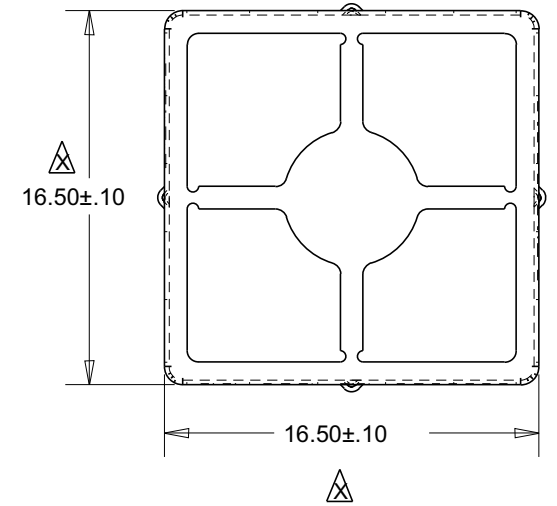
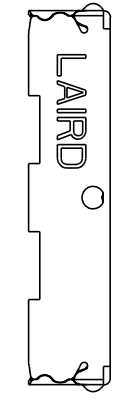
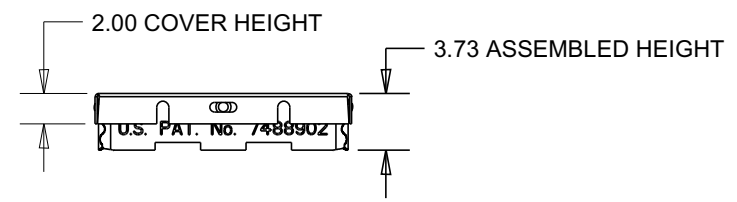
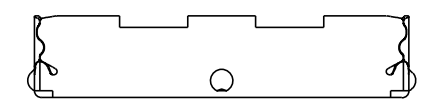

FOOTPRINT  
SCALE 2.000

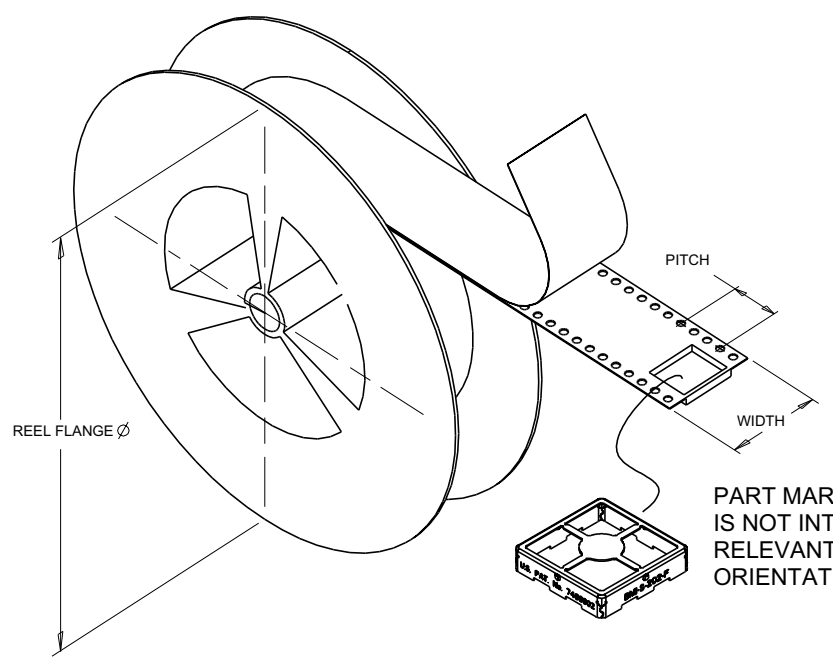

PART MARKING ON SIDES IS NOT INTENDED TO BE RELEVANT TO PART ORIENTATION IN CARRIER TAPE.

CRITICAL DIMENSIONS ARE DESIGNATED BY

		PART DESCRIPTION: BOARD LEVEL SHIELD		PART NUMBER: <b>BMI-S-202-SALES</b>	
		CUSTOMER: LAIRD CATALOG		MODELED BY: TIM WRONA	
3RD ANGLE PROJECTION		PROGRAM NAME: STANDARDS		DATE: 05/10/12	REV: -
DESIGNED IN PRO/ENGINEER		CUSTOMER PART NUMBER: N/A	REV: -	APPROVED BY: X	DATE: XX/XX/XX
SCALE: 4.000	SHEET 1 OF 1	INFORMATION CONTAINED IN THIS DOCUMENT IS CONFIDENTIAL AND PROPRIETARY TO LAIRD TECHNOLOGIES. IT MAY NOT BE DISCLOSED TO ANYONE WITHOUT WRITTEN AUTHORIZATION FROM LAIRD TECHNOLOGIES.		<b>SALES</b>	