



Figure 1. Photo of AD202KY (Made by ATI)

FEATURES

- Isolated Power Outputs
- Small Size: 4 Channels/Inch Low
- Uncommitted Input Amplifier
- High CMR: 130dB (Gain = 100V/V)
- High Accuracy: $\pm 0.01\%$ Max Nonlinearity
- High CMV Isolation: $\pm 2000\text{V}$ Continuous

APPLICATIONS

It can be applied for multichannel data acquisition, current shunt measurements motor controls, process signal isolation, high voltage instrumentation amplifier, etc.

DESCRIPTION

Upgraded Drop-in Replacement for AD202KY

The AD202KY (Made by ATI) is a high voltage isolation amplifier designed for multiple applications where input signals are measured, processed, or transmitted without a galvanic connection. These isolation amplifiers in SIP package offer a signal and power isolation function.

With internal transformer-coupling, the AD202KY (Made by ATI) provides total galvanic isolation between the input and output stages of the isolation amplifier. These amplifiers eliminate the need for an external DC-DC converter, which allows the designer to minimize the necessary circuit overhead, thus reducing the overall design and component costs.

The AD202KY (Made by ATI) is powered directly from a 15V DC power supply, featuring small size, high accuracy, low power, wide bandwidth, excellent performance, flexible input, isolated power, etc.

INSIDE THE AD202KY (Made by ATI)

The AD202KY (Made by ATI) uses an amplitude modulation technique to permit transformer coupling of signals down to dc (Figure 2). It also contains an uncommitted input op amp and a power transformer that provides isolated power to the op amp, the modulator, and any external load. The power transformer primary is driven by a 20kHz, 15V_{P-P} square wave generated internally.

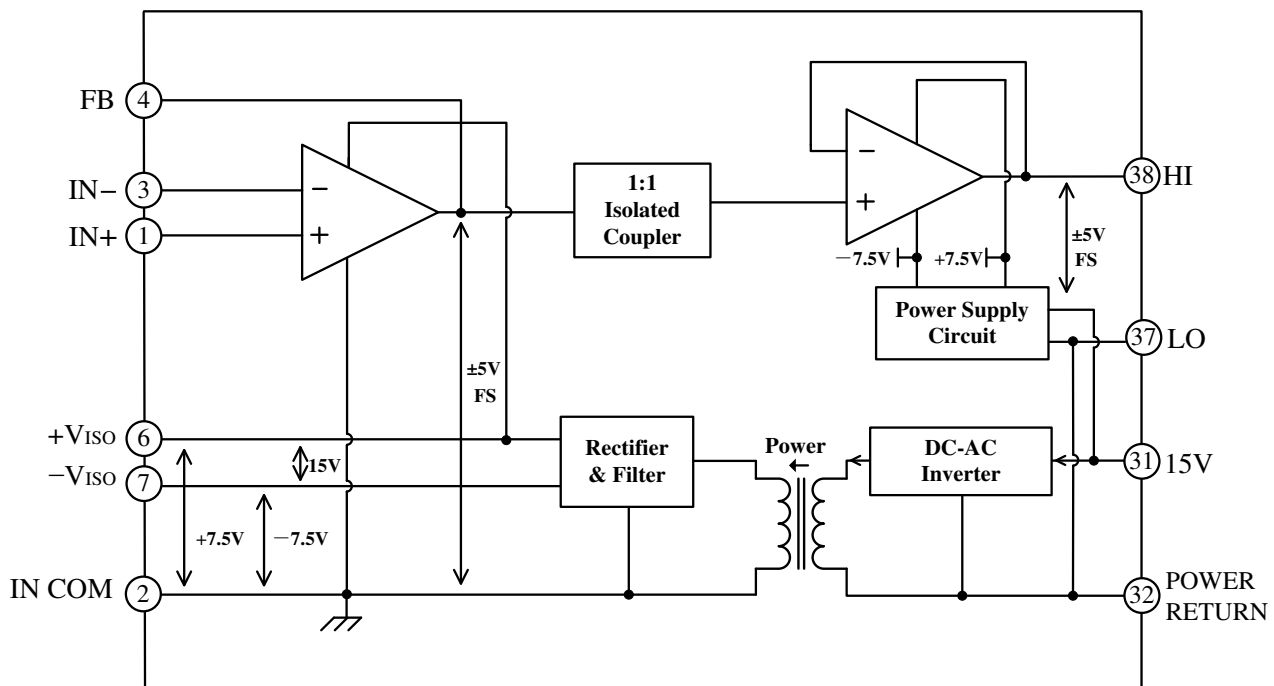

Figure 2. AD202KY (Made by ATI) Functional Block Diagram



SPECIFICATIONS

Table 1. Electrical characteristics. (Typical @ 25°C and $V_S = 15V$ unless otherwise noted.)

Model	AT202KY
GAIN	
Range	1V/V–100 V/V
Error	±0.5% typ (±4% max)
vs. Temperature	±20ppm/°C typ (±45ppm/°C max)
vs. Time	±50 ppm/1000 Hours
vs. Supply Voltage	±0.01%/V
Nonlinearity (G = 1V/V)	±0.01 max
Nonlinearity vs. Isolated Supply Load	±0.0015%/mA
INPUT VOLTAGE RATINGS	
Input Voltage Range	±5V
Max Isolation Voltage (Input to Output)	
AC, 60Hz, Continuous	1500Vms
Continuous (AC and DC)	±2000V Peak
CMRR (Common-Mode Rejection Ratio)*	–74dB
CMTC(Common-Mode Transfer Coefficient)*	–0.2×10 ³
RS ≤ 100Ω (HI and LO Inputs) G = 1V/V	105dB
G = 100V/V	130dB
RS ≤ 1 kΩ (Input HI, LO, or Both) G = 1V/V	100dB min
G = 100V/V	110dB min
Leakage Current Input to Output @ 240Vrms, 60 Hz	2μA rms max
INPUT IMPEDANCE	
Differential (G = 1V/V)	10 ¹² Ω
Common-Mode	2GΩ/4.5pF
INPUT BIAS CURRENT	
Initial, @ 25°C	±30pA
vs. Temperature (0°C to 70°C)	±10nA
INPUT DIFFERENCE CURRENT	
Initial, @ 25°C	±5pA
vs. Temperature (0°C to 70°C)	±2nA
INPUT NOISE	
Voltage, 0.1Hz to 10Hz	1.8μV _{P-P}
f > 100Hz	10.8nV/√Hz
FREQUENCY RESPONSE	
Bandwidth ($V_O \leq 10V_{P-P}$, G = 1V–50V/V)	20kHz
Settling Time, to ±10mV (10V Step)	1ms
OFFSET VOLTAGE (RTI)	
Initial, @ 25°C Adjustable to Zero	(±5 ± 5/G)mV max
vs. Temperature (0°C to 70°C)	[±10 ± $\frac{10}{G}$] μV/°C
RATED OUTPUT	
Voltage (Out HI to Out LO)	±5V
Output Resistance	7kΩ
Output Ripple, 100kHz Bandwidth	10mV _{P-P}
5kHz Bandwidth	0.5mV rms
ISOLATED POWER OUTPUT	
Voltage, No Load	±7.5V
Accuracy	±10%
Current	400μA Total
Regulation, No Load to Full Load	5%
Ripple	100mV _{P-P}
POWER SUPPLY	
Voltage, Rated Performance	15V±5%
Voltage, Operating	15V±10%
Current, No Load ($V_S = 15V$)	10mA
TEMPERATURE RANGE	
Rated Performance	0°C to 70°C
Operating	–40°C to +85°C
Storage	–40°C to +85°C
PACKAGE DIMENSIONS	
DIP Package (N)	2.10"×0.700"×0.350"

*Test Schematic Figure 3 @ 100Hz Sine Wave @ $v_s(t) = 1000V$.

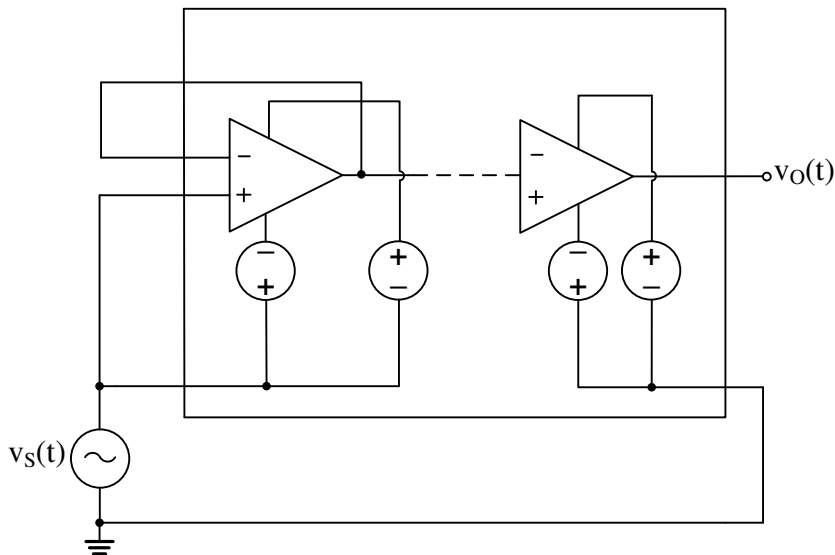

Figure 3. CMRR & CMTC Test Schematic

PIN DESIGNATIONS

Block	Pin #	Pin Name	Type	Function Description
Isolated Block	1	IN+	Isolated analog input	Isolated positive (Non-inverting) input
	2	IN COM	Isolated analog ground	Isolated ground
	3	IN-	Isolated analog input	Isolated negative (inverting) input
	6	+VISO OUT	Isolated power output	Isolated positive power supply output, +7.5V, referenced to pin 2 IN COM
	5	-VISO OUT	Isolated power output	Isolated negative power supply output, approximately -7.0V, referenced to pin 2 IN COM
	4	FB	Isolated analog output	Isolated op amp output as a feedback signal
Local Block	37	LO	Analog ground	Output voltage ground reference, internally connected to pin 22 POWER RETURN
	38	HI	Analog output	Op amp output, equals to the voltage difference between FB and IN COM
	31	15 V	Analog input	Positive 15V power supply input
	32	POWER RETURN	Analog input	Power supply return, internally connected to pin 18 GND



MECHANICAL DIMENSIONS

The dimensions of AD202KY (Made by ATI) in SIP package are shown in Figure 3.

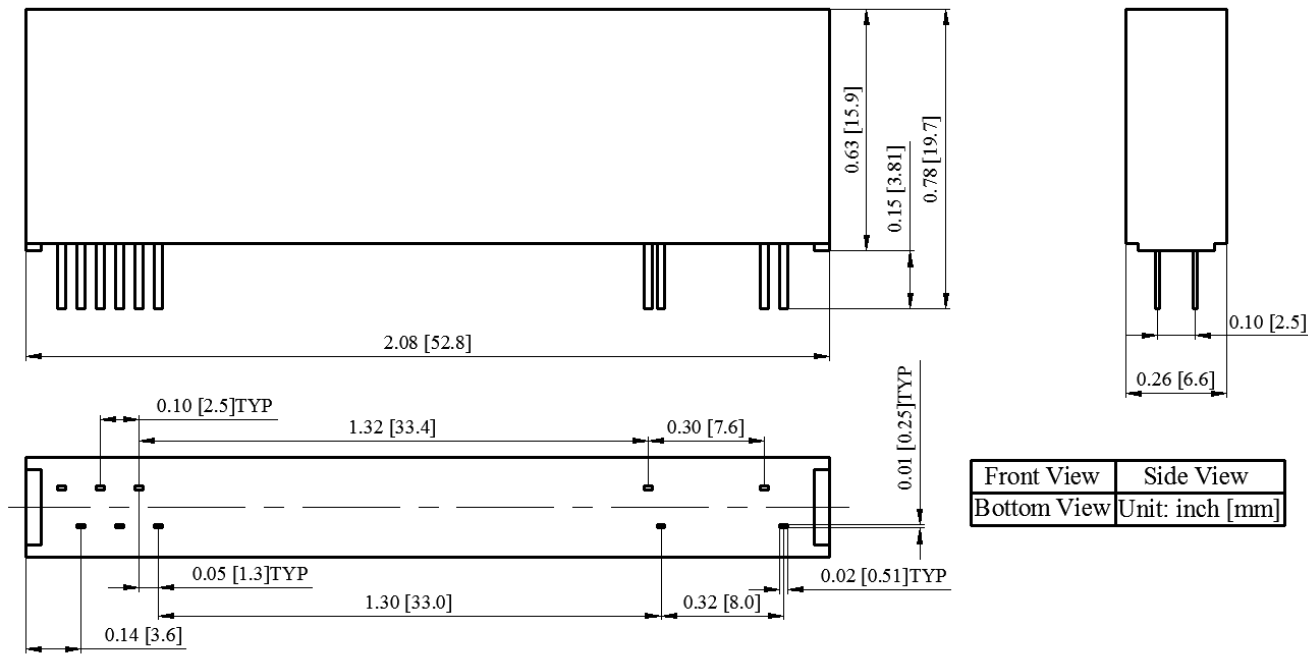

Figure 3. Dimensions of AD202KY (Made by ATI) SIP Package



NOTICE

1. ATI warrants performance of its products for one year to the specifications applicable at the time of sale, except for those damaged by excessive abuse. Products found not meeting the specifications within one year from the date of sale can be exchanged free of charge.
2. ATI reserves the right to make changes to its products or to discontinue any product or service without notice and advise customers to obtain the latest version of relevant information to verify, before placing orders, that the information being relied on is current and complete.
3. All products are sold subject to the terms and conditions of sale supplied at the time of order acknowledgment, including those pertaining to warranty, patent infringement, and limitation of liability. Testing and other quality control techniques are utilized to the extent ATI deems necessary to support this warranty. Specific testing of all parameters of each device is not necessarily performed, except those mandated by government requirements.
4. Customers are responsible for their applications using ATI products. In order to minimize risks associated with the customers' applications, adequate design and operating safeguards must be provided by the customers to minimize inherent or procedural hazards. ATI assumes no liability for applications assistance or customer product design.
5. ATI does not warrant or represent that any license, either expressed or implied, is granted under any patent right, copyright, mask work right, or other intellectual property right of ATI covering or relating to any combination, machine, or process in which such products or services might be or are used. ATI's publication of information regarding any third party's products or services does not constitute ATI's approval, warranty or endorsement thereof.
6. IP (Intellectual Property) Ownership: ATI retains the ownership of full rights for special technologies and/or techniques embedded in its products, the designs for mechanics, optics, plus all modifications, improvements, and inventions made by ATI for its products and/or projects.