

REVISIONS			
REV.	DESCRIPTION	DATE	APPROVED
A	INITIAL RELEASE	04/11/13	J.S.

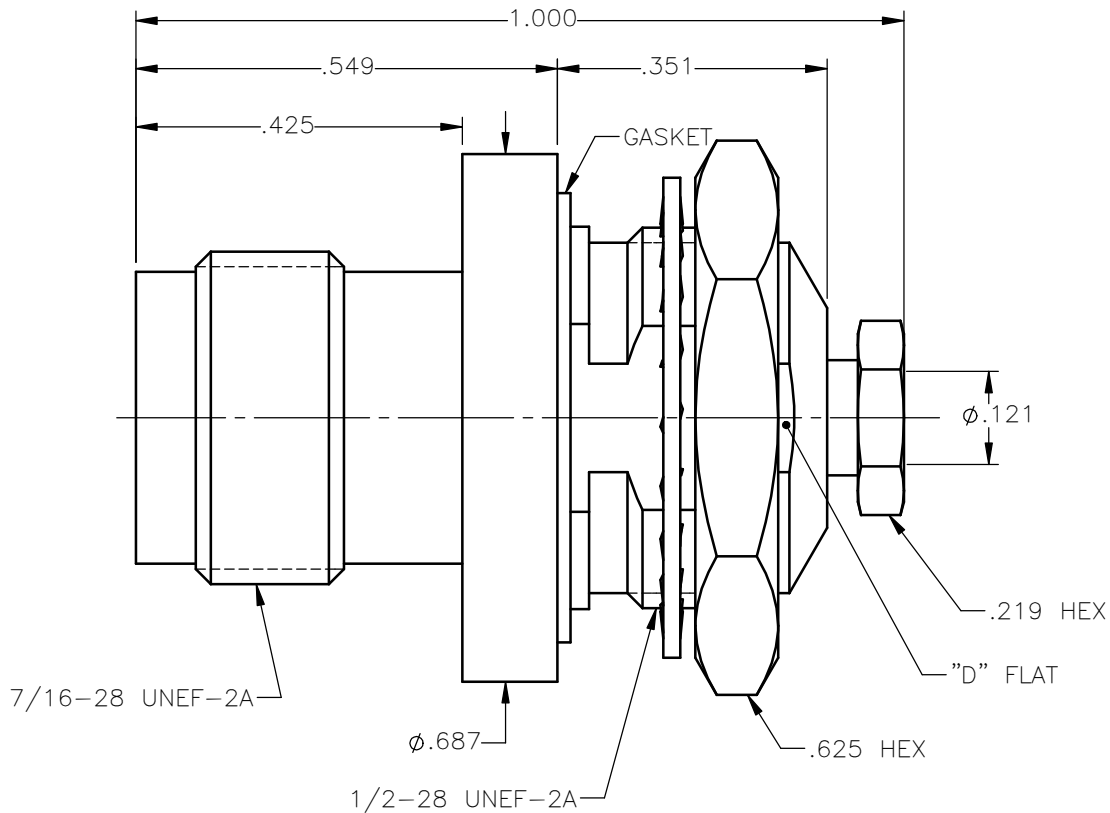



NOTES:

MATERIALS:

1. CONTACT = BERYLLIUM COPPER PER ASTM B196, ALLOY C17300, TEMPER TD04.
2. INSULATORS = VIRGIN WHITE TEFLON PER ASTM D1710, GRADE 1, TYPE I, CLASS "B".
3. LOCKWASHER = PHOSPHOR BRONZE PER ASTM B139, COPPER ALLOY C53400, TEMPER H04.
4. ALL OTHER METAL PARTS = BRASS PER ASTM B16, ALLOY C36000, TEMPER H02.
5. GASKET = SILICONE RUBBER 45-55 DUROMETER DOW CORNING SILASTIC 250.

FINISHES:

1. CONTACT & WIRE ADAPTER = GOLD PLATE PER MIL-G-45204, TYPE II, CLASS 1, GRADE C, OVER .00010 TO .00020 STRESS FREE SULFAMATE NICKEL PER QQ-N-290.
2. ALL OTHER METAL PARTS = GOLD PLATE PER MIL-G-45204, TYPE II, CLASS 0, GRADE C, OVER .00010 TO .00020 COPPER STRIKE PER MIL-C-14550.

UNLESS OTHERWISE SPECIFIED DIMENSIONS ARE IN INCHES TOLERANCES ON	DWN: J.S.	DATE 04/11/13	 Property of Radiall This document cannot be reproduced or communicated to a third party without prior written permission of RADIALL.		
	CHKD: D.N.	DATE 04/11/13			
DECIMAL	ANGLE	APVD: J.M.	TNC STRAIGHT JACK BULKHEAD FRONT MOUNT CLAMP SOLDER TYPE FOR .085 S/R AND SIMILAR CABLES		
REFERENCE:	MATERIALS & FINISHES: SEE NOTES	SIZE A	FSCM NO. 19505	DWG NO. 6002-1041-010	REV A
ORIGINATED: J.S. DATE: 04/11/13		SCALE 4:1	THIRD ANGLE PROJECTION		SHEET 1 OF 1

6002-1041-010