

PRE - ASSEMBLY INSTRUCTIONS:

Caution: Check gasket on top of base unit for damage before assembly. If cut or torn, contact Hammond Manufacturing for immediate replacement.

Note: When assembling total modular system build from the floor up for assembly ease. Plinth > Base Unit > Desk Unit > Turret

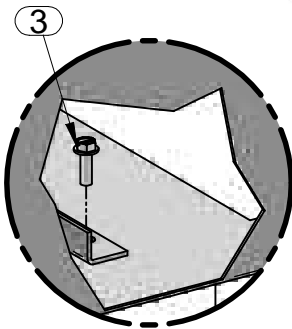

DETAIL A

SEE STEP D FOR INSTRUCTIONS

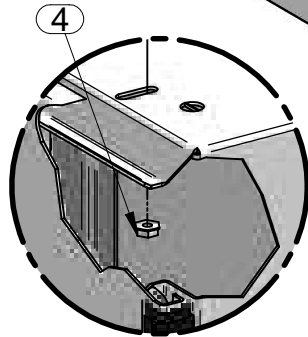



DETAIL B

ASSEMBLY INSTRUCTIONS:

- A) Open doors or remove doors for ease of assembly. This will allow for visual alignment of mating parts. Avoid handling or hitting gasket on objects.
- B) Align desk (item 1) over top opening in base unit (item 2). Side edges of desk and base are to be flush.
- C) Front and rear slots in desk bottom are to be aligned with mounting slots on base top.
- D) Once the desk is seated properly on the base assemble using 1/4-20 x .75 HEX HD. screws and 1/4-20 KEP nuts (item 3 & 4) provided. Torque screws and nuts to 115 in/lbs.

| PARTS LIST | | |
|------------|----------------------------|------------|
| ITEM No. | DESCRIPTION | QTY |
| 1 | DESK UNIT | 1 |
| 2 | BASE UNIT | 1 |
| 3 | 1/4-20 X 3/4 HEX CAP SCREW | 4, 6, or 8 |
| 4 | 1/4-20 KEP NUT | 4, 6, or 8 |

| | | |
|--|---|--|
| TOOL BOX  | 3/8, 7/16" Socket Wrench  | 3/8, 7/16 Open Wrench  |
|--|---|--|

