

LOC	DIST	REVISIONS			
		REV	DATE	BY	CHKD
GP	00				
		C1	REVISED PER ECO-11-004835	11MAR2011	RK HMR
		D	REVISED PER ECO-12-005533	31MAR2012	JY AC
		E	REVISED PER ECO-13-009872	26NOV2013	RG MC
		F	REVISED PER ECO-14-016878	30EC2014	RG MC

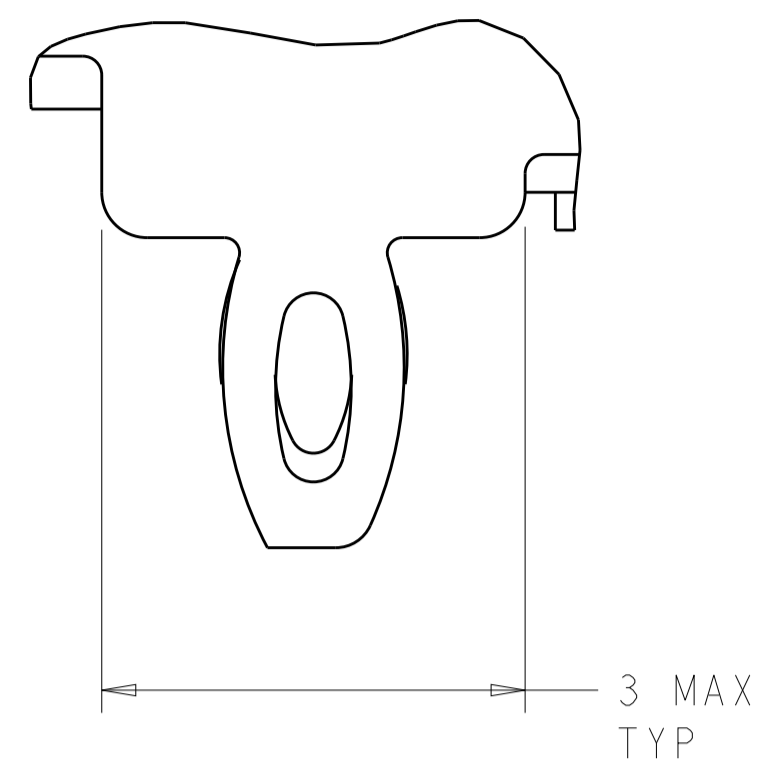

DETAIL S $\Delta 12$
 SCALE 20:1

- $\Delta 1$ CAGE ASSEMBLY MATERIAL: NICKEL SILVER, 0.25 THICK
 HEAT SINK MATERIAL: ALUMINUM
 HEAT SINK CLIP MATERIAL: STAINLESS STEEL
 EMI SPRINGS MATERIAL: COPPER ALLOY
 FRONT FLANGE MATERIAL: ZINC ALLOY
 LIGHT PIPE MATERIAL: CLEAR POLYCARBONATE
- $\Delta 2$ PITCH BETWEEN PORTS OF ONE 1X3 CAGE ASSEMBLY.
- $\Delta 3$ SPACING BETWEEN CAGES ON THE SAME PC BOARD, TO BE SPECIFIED BY CUSTOMER, MUST COMPLY WITH MINIMUM DIMENSIONS SHOWN.
- $\Delta 4$ REFERENCE APPLICATION SPEC 114-13218 FOR RECOMMENDED DRILL HOLE DIAMETER AND PLATING THICKNESS.
- $\Delta 5$ DATUMS AND BASIC DIMENSIONS ESTABLISHED BY CUSTOMER.
- $\Delta 6$ DIMENSION F IS THE NOMINAL THICKNESS OF CUSTOMER SUPPLIED PC BOARD, SINGLE SIDED PC BOARD MINIMUM THICKNESS = 1.45mm, DOUBLE SIDED PC BOARD MINIMUM THICKNESS = 2.2mm PER QSFP
- $\Delta 7$ HEAT SINKS, LIGHT PIPES, AND HEAT SINK CLIPS SHIPPED ASSEMBLED TO CAGE ASSEMBLY. CAGE ASSEMBLY MAY BE PRESSED INTO THE PCB AS SHIPPED.
- $\Delta 8$ DATUM -A- IS TOP SURFACE OF PC BOARD.
- $\Delta 9$ DIMENSION APPLIES WITH MODULE INSERTED IN CAGE.
- $\Delta 10$ UNPLATED THRU HOLE.
- 11. MATES WITH QSFP MSA COMPATIBLE TRANSCEIVER.
- $\Delta 12$ SURFACE TRACES PERMITTED WITHIN THIS AREA EXCEPT WHERE CAGE STANDOFFS, SHOWN IN DETAIL S, CONTACT PC BOARD.
- $\Delta 13$ BASELINE FOR THESE DIMENSIONS IS THE CENTER OF COMPLIANT PIN HOLE.
- $\Delta 14$ 2D BARCODE AND DATE CODE (YYWWD) MARKED ON SIDE OF CAGE ASSEMBLY.

- $\Delta 15$ REFERENCE APP SPEC 114-13218 FOR GASKET THICKNESS CALCULATION.
- $\Delta 16$ EMI SPRING FINISH: 2 μ m MIN TIN
 FRONT FLANGE FINISH: 3 μ m MIN TIN OVER 1.27 μ m MIN NICKEL OVER 5.08 μ m MIN COPPER.
 HEAT SINK FINISH: BLACK ANODIZED.
- $\Delta 17$ HEAT SINKS AND CLIPS SHIPPED ASSEMBLED TO CAGE ASSEMBLY. CAGE ASSEMBLY MAY BE PRESSED IN TO THE PCB AS SHIPPED. LIGHT PIPES, SHIPPED UNATTACHED, MUST BE ASSEMBLED BY CUSTOMER AFTER THE CAGE IS SEATED IN THE PCB.

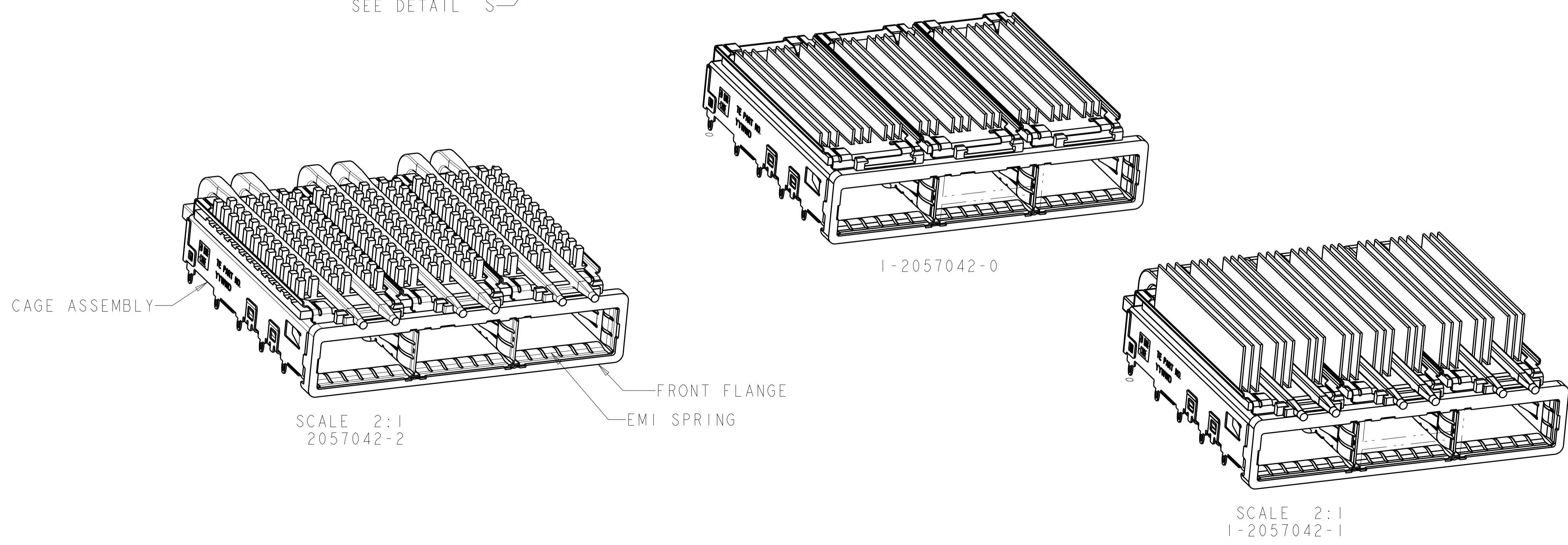
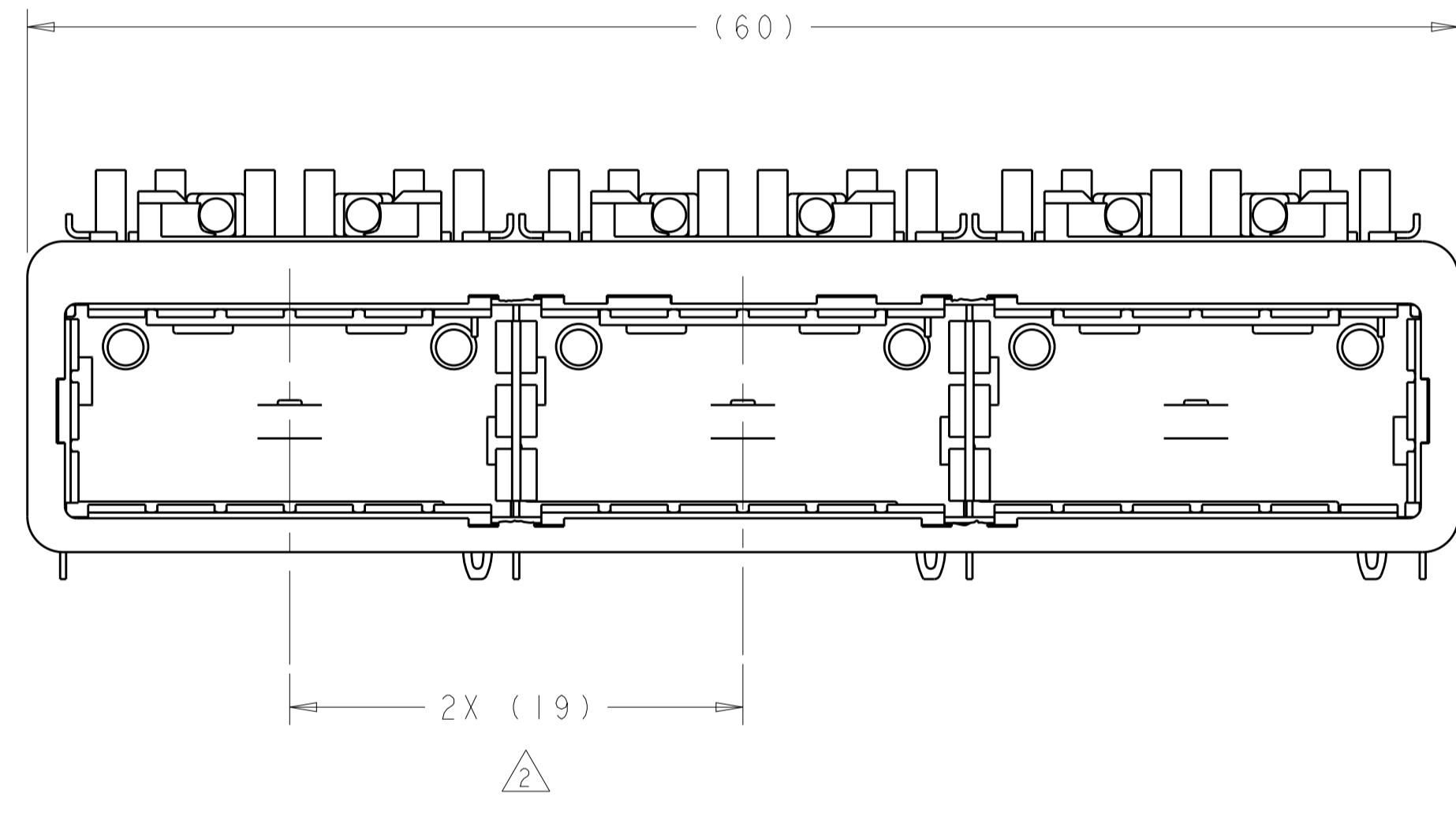
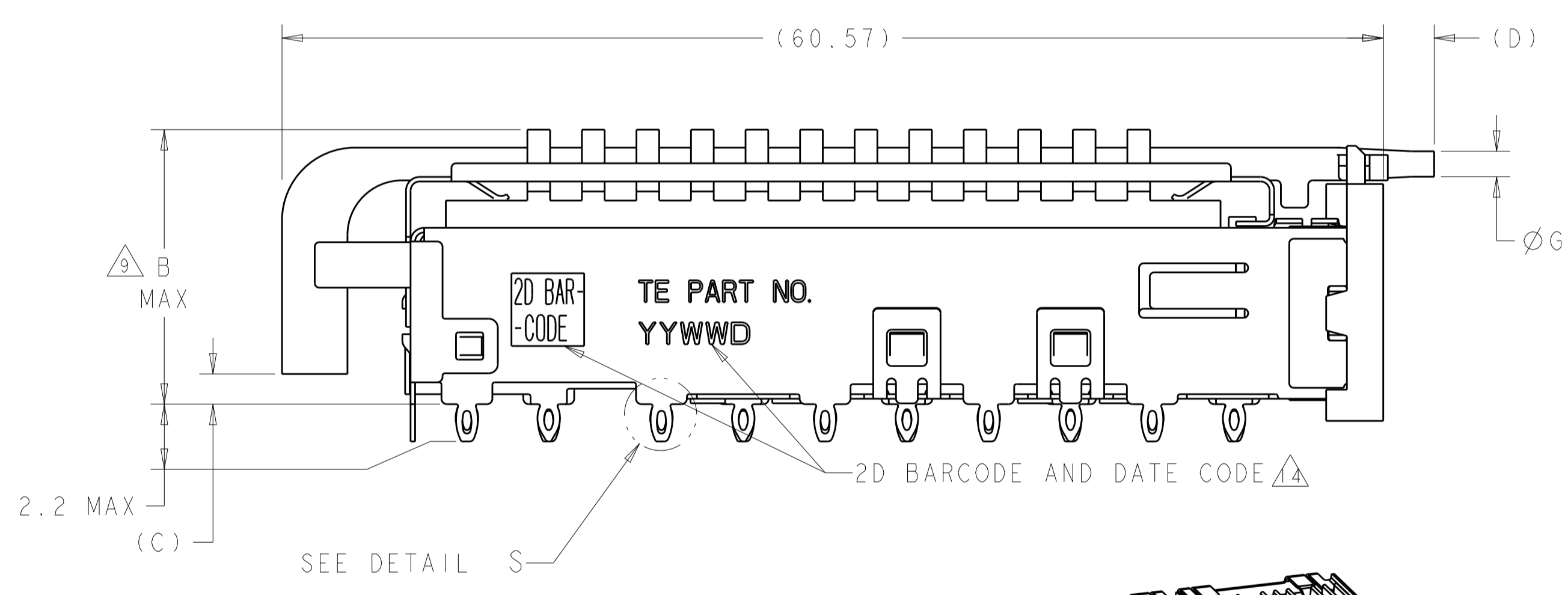

$\Delta 1$	1.4	0.8-1.1	2.0	1.70	21.0	FIN TYPE	1-2057042-1
	N/A	N/A	N/A	N/A	15.0	FIN TYPE	1-2057042-0
$\Delta 1$	2.0	0.8-1.1	3.5	1.70	16.8	CUSTOMERIZED	2057042-9
$\Delta 1$	1.4	0.8-1.1	2.0	1.70	23.0	NETWORKING	2057042-8
$\Delta 1$	1.4	0.8-1.1	2.0	1.70	16.0	SAN	2057042-7
$\Delta 1$	1.4	0.8-1.1	2.0	1.70	13.7	PCI	2057042-6
$\Delta 1$	1.4	1.3-1.4	5.7	2.15	16.0	SAN	2057042-5
$\Delta 1$	1.4	1.3-1.4	5.7	2.15	13.7	PCI	2057042-4
$\Delta 1$	1.4	0.8-1.1	2.8	1.70	23.0	NETWORKING	2057042-3
$\Delta 1$	1.4	0.8-1.1	2.8	1.70	16.0	SAN	2057042-2
$\Delta 1$	1.4	0.8-1.1	2.8	1.70	13.7	PCI	2057042-1
	G	E	D	C	B	HEAT SINK PROFILE	PART NUMBER

THIS DRAWING IS A CONTROLLED DOCUMENT. DWN: C. VALENTINI 28FEB2008
 CHK: E. BRIGHT 28FEB2008
 APVD: E. BRIGHT 28FEB2008

TE Connectivity

NAME: 1X3 CAGE ASSEMBLY, BEHIND BEZEL, W/ LIGHT PIPES AND HEAT SINKS, QSFP

PRODUCT SPEC: 108-2286
 APPLICATION SPEC: 114-13218

SIZE: A1 CAGE CODE: 00779C DRAWING NO: 2057042

RESTRICTED TO: -

CUSTOMER DRAWING SCALE: 4:1 SHEET: 1 OF 5 REV: F

LOC	DIST	REVISIONS			
P	LYR	DESCRIPTION	DATE	DMN	APVD
GP	00	SEE SHEET 1	-	-	-

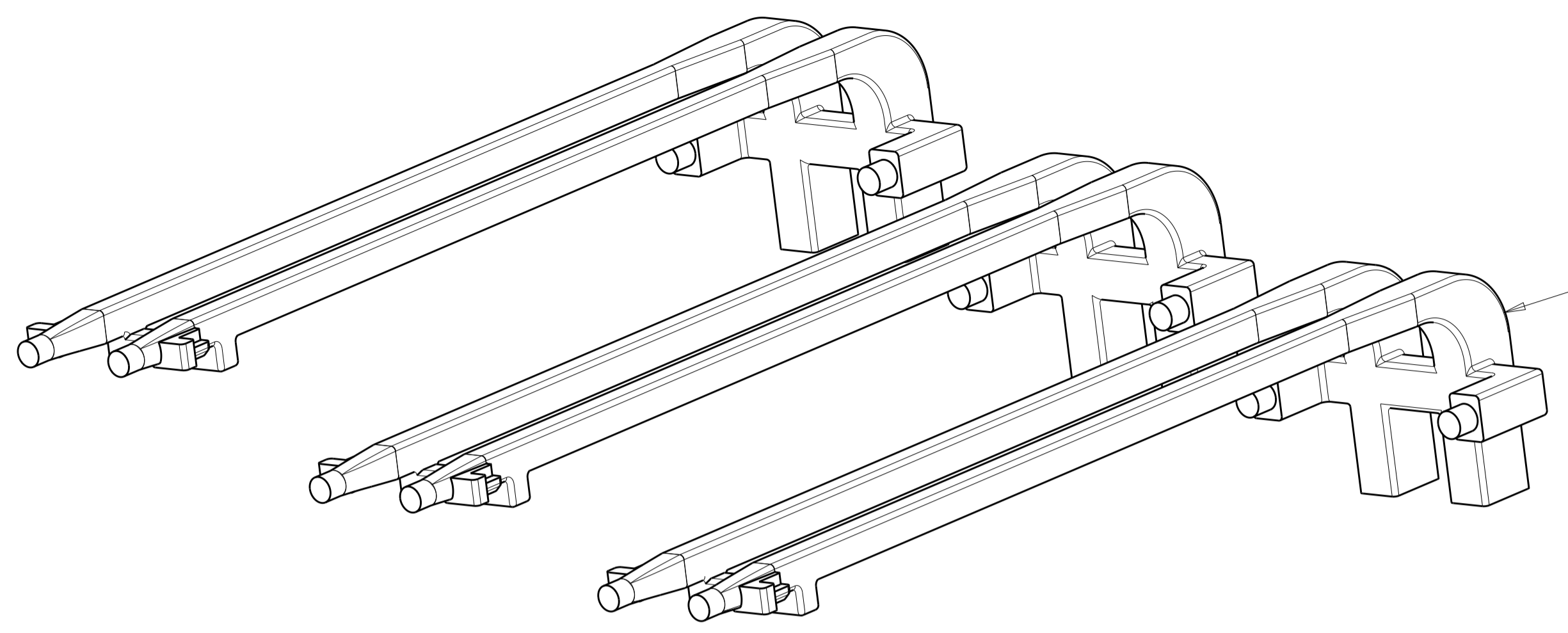

DOUBLE LIGHT PIPES
 QUANTITY: 3

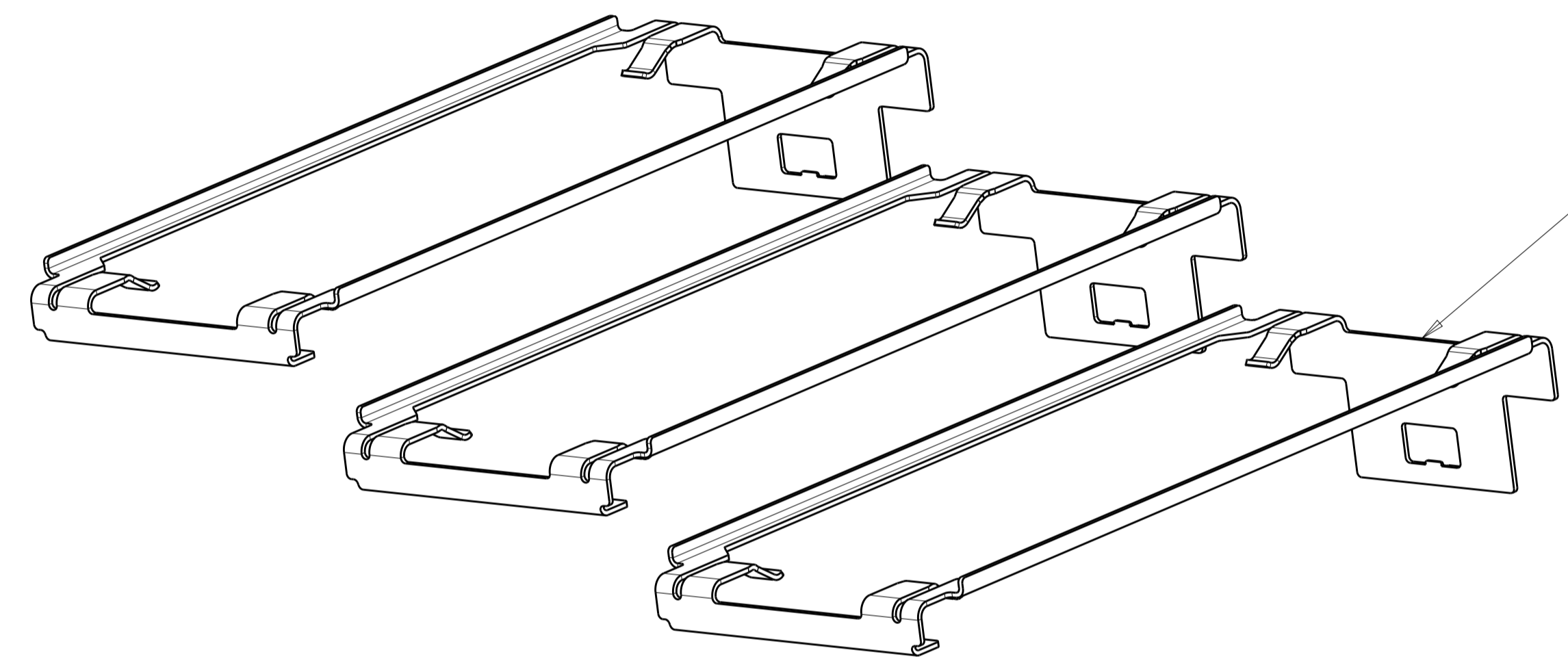

HEAT SINK CLIPS
 QUANTITY: 3

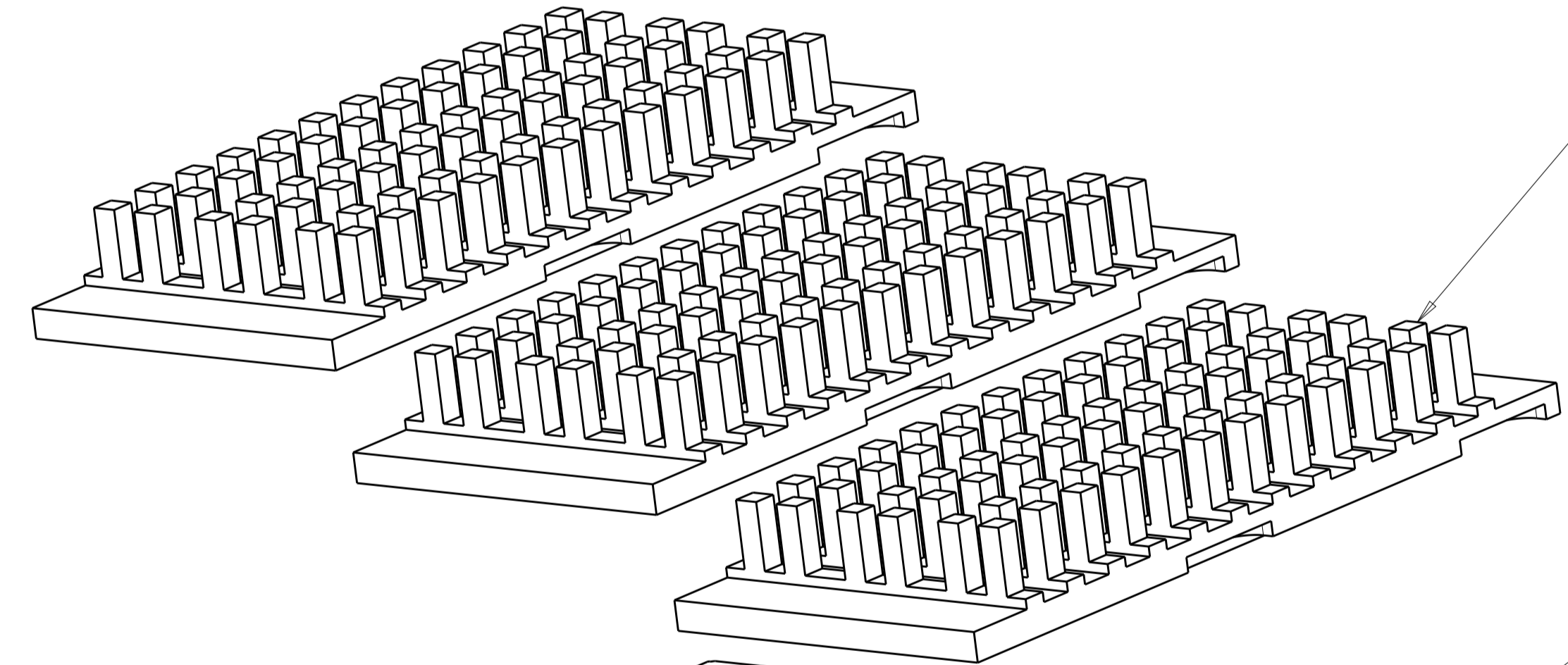

72 PIN HEAT SINKS
 QUANTITY: 3

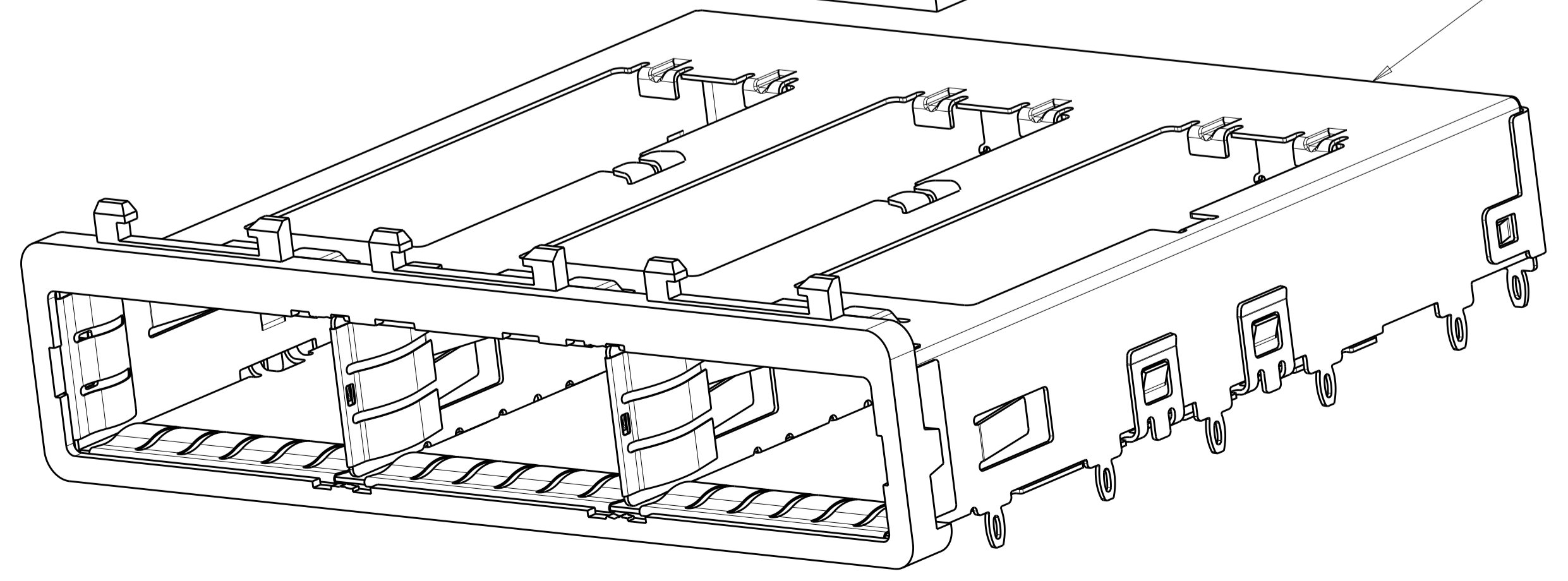

1X3 BEHIND BEZEL QSFP
 CAGE ASSEMBLY
 QUANTITY: 1

THIS PRODUCT HAS NOT COMPLETED
 VALIDATION/QUALIFICATION TESTING

THIS DRAWING IS A CONTROLLED DOCUMENT.		DMN C. VALENTIN 28FEB2008	TE Connectivity
DIMENSIONS: mm		CHK E. BRIGHT 28FEB2008	
TOLERANCES UNLESS OTHERWISE SPECIFIED:		APVD E. BRIGHT 28FEB2008	NAME 1X3 CAGE ASSEMBLY, BEHIND BEZEL, W/ LIGHT PIPES AND HEAT SINKS, QSFP
0 PLC ±		PRODUCT SPEC	SIZE A100779C=2057042
1 PLC ±0.1		108-2286	RESTRICTED TO
2 PLC ±0.1		APPLICATION SPEC	SCALE 4:1 SHEET 2 OF 5 REV F
3 PLC ±		114-13218	
4 PLC ±		WEIGHT	
ANGLES ±		CUSTOMER DRAWING	
FINISH			

LOC	DIST	REVISIONS					
GP	00	P	LTN	DESCRIPTION	DATE	OWN	APVD
-	-	-	-	SEE SHEET 1	-	-	-

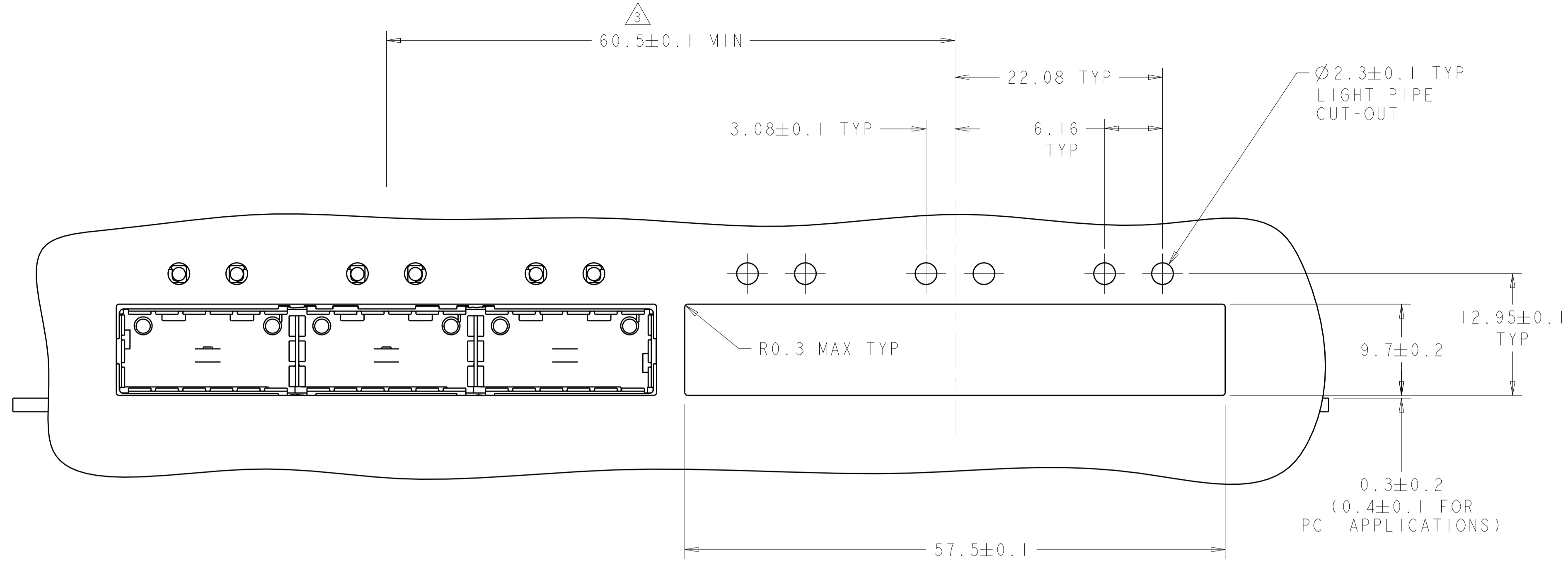

ONE SIDED CONFIGURATION
 SCALE 3:1

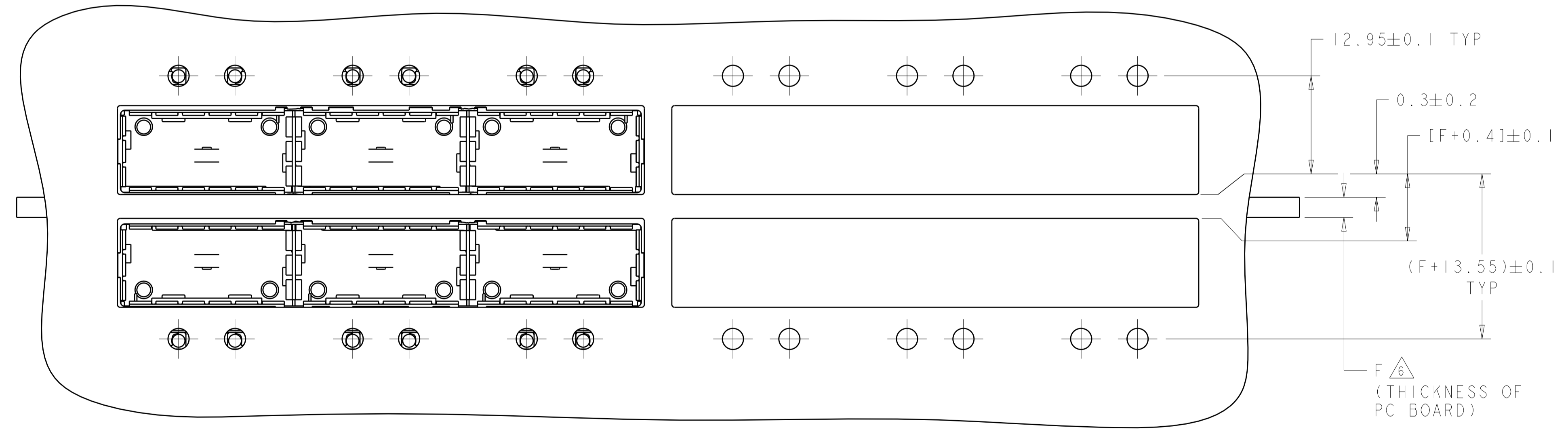
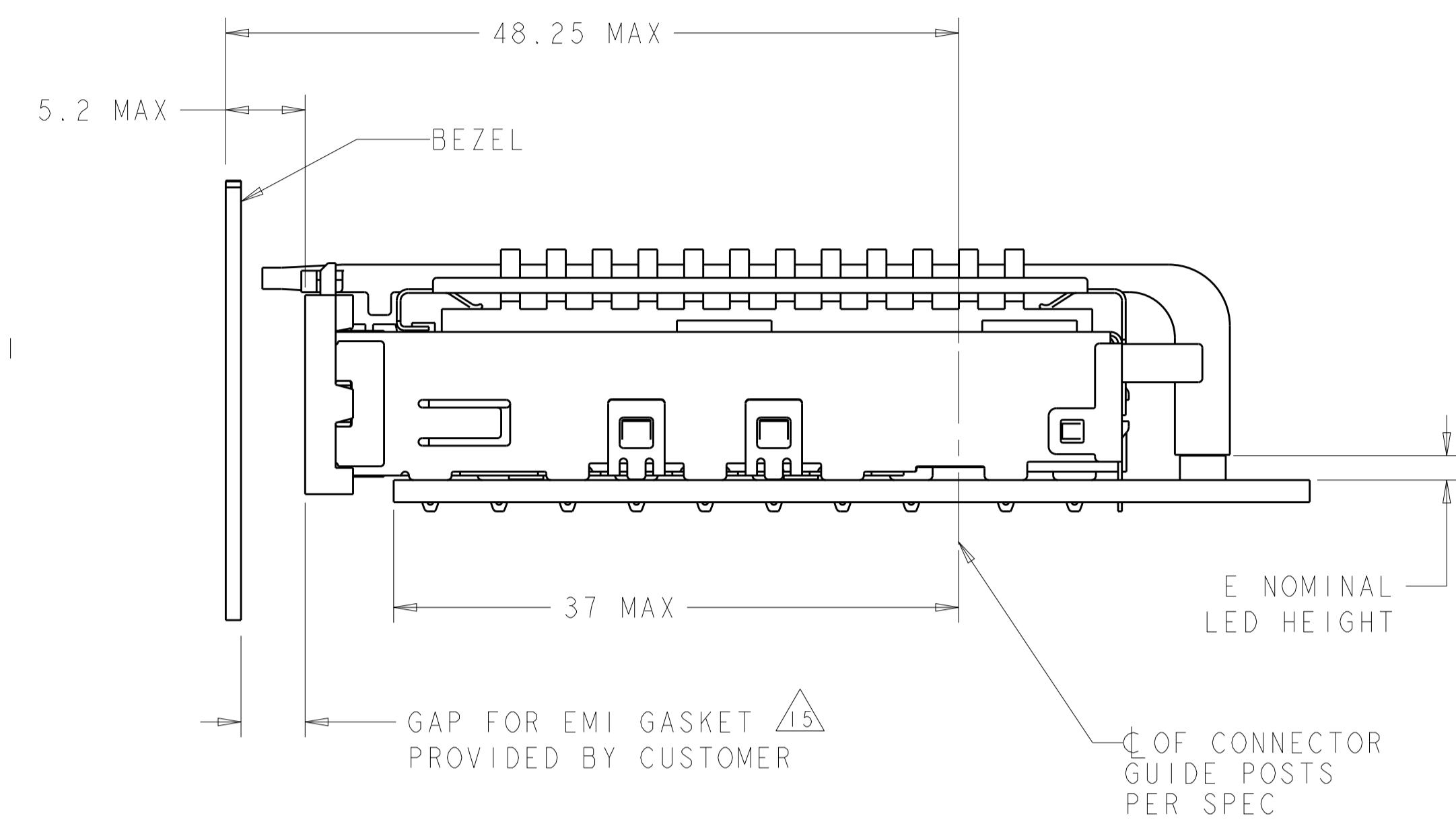

BELLY TO BELLY CONFIGURATION SIMILAR
 TO ONE SIDED EXCEPT WHERE NOTED
 SCALE 3:1

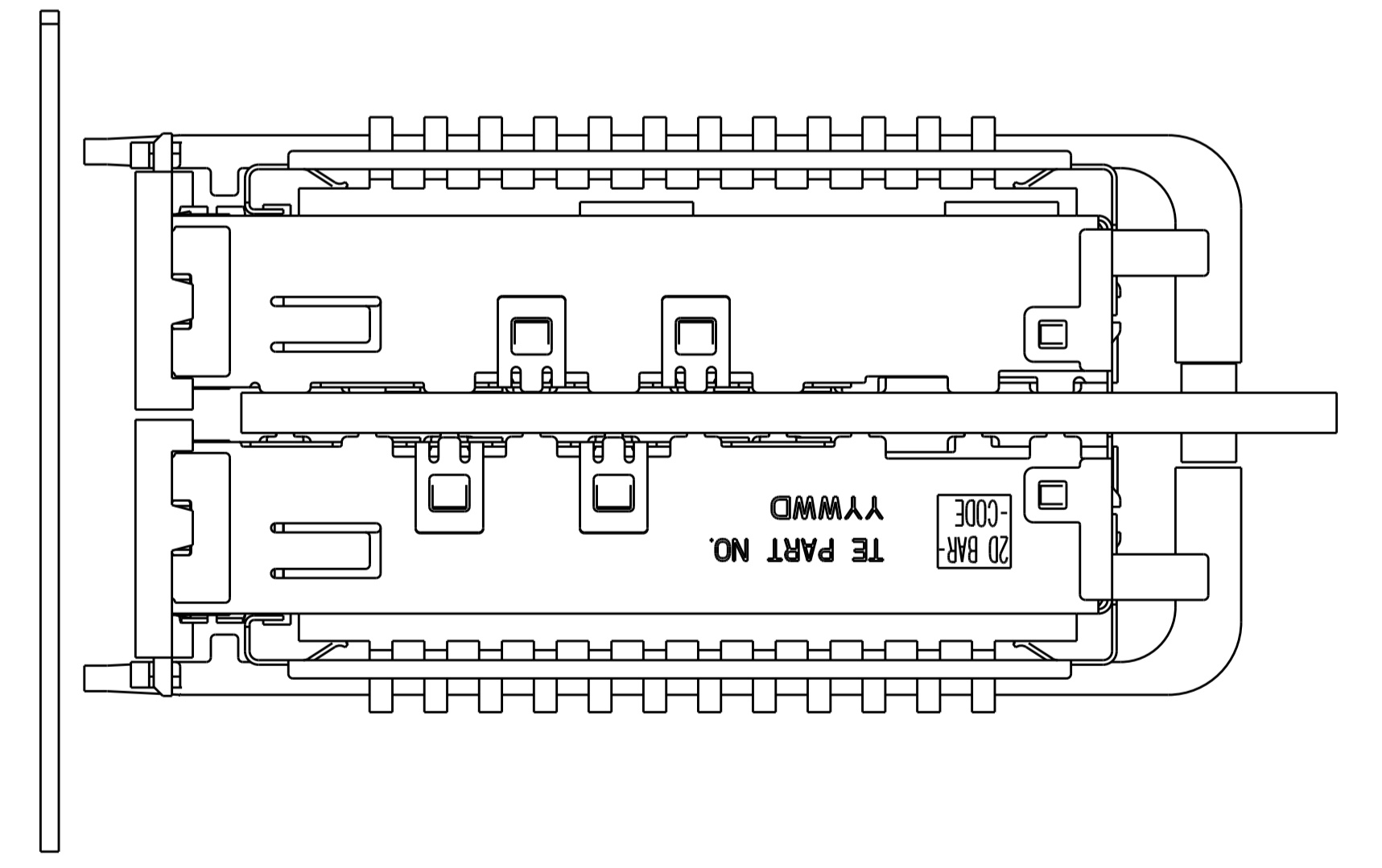

THIS PRODUCT HAS NOT COMPLETED VALIDATION/QUALIFICATION TESTING

THIS DRAWING IS A CONTROLLED DOCUMENT.		OWN C. VALENTINE 28FEB2008	TE Connectivity
DIMENSIONS:		CHK E. BRIGHT 28FEB2008	
TOLERANCES UNLESS OTHERWISE SPECIFIED:		APVD E. BRIGHT 28FEB2008	NAME 1X3 CAGE ASSEMBLY, BEHIND BEZEL, W/ LIGHT PIPES AND HEAT SINKS, QSFP
mm	0 PLC ±	PRODUCT SPEC	SIZE CAGE CODE DRAWING NO
	1 PLC ±0.1	108-2286	A100779C=2057042
	2 PLC ±0.1	APPLICATION SPEC	RESTRICTED TO
	3 PLC ±	114-13218	
	4 PLC ±	WEIGHT	
	ANGLES ±		
MATERIAL	FINISH	CUSTOMER DRAWING	SCALE 4:1 SHEET 3 OF 5 REV F

LOC	DIST	REV	DATE	BY	APPV
GP	00				

REVISIONS			
NO.	DESCRIPTION	DATE	BY
1	SEE SHEET 1		

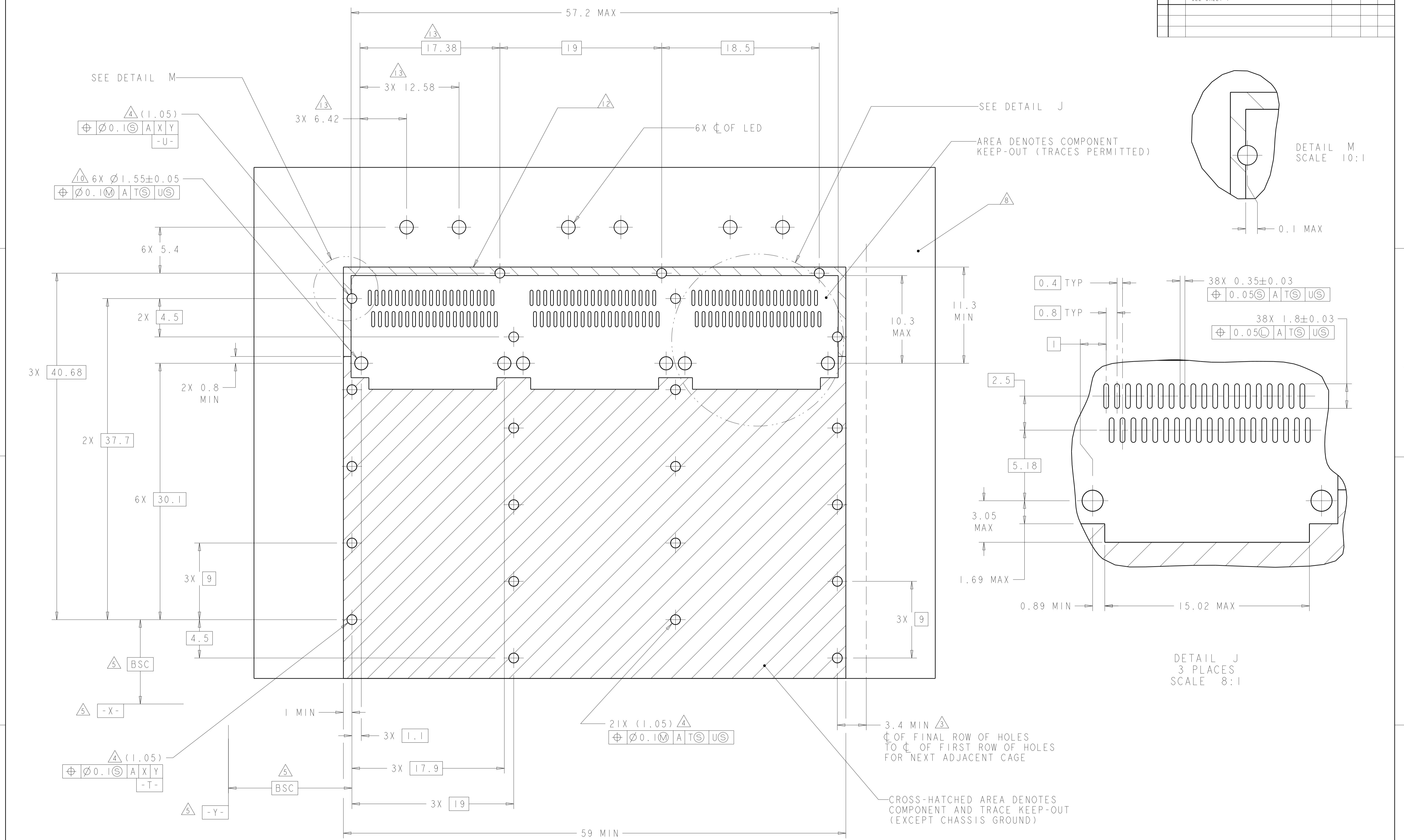

RECOMMENDED PC BOARD LAYOUT
 SINGLE SIDE MOUNT CONFIGURATION
 SCALE 5:1

THIS PRODUCT HAS NOT COMPLETED VALIDATION/QUALIFICATION TESTING

THIS DRAWING IS A CONTROLLED DOCUMENT.		OWN: C. VALENTINE 28FEB2008	TE Connectivity
DIMENSIONS: mm		CHK: E. BRIGHT 28FEB2008	
TOLERANCES UNLESS OTHERWISE SPECIFIED:		APPV: E. BRIGHT 28FEB2008	NAME: 1X3 CAGE ASSEMBLY, BEHIND BEZEL, W/ LIGHT PIPES AND HEAT SINKS, QSFP PRODUCT SPEC: 108-2286 APPLICATION SPEC: 114-13218 WEIGHT: - CUSTOMER DRAWING
0 PLC \pm		PRODUCT SPEC: 108-2286	
1 PLC \pm 0.1		APPLICATION SPEC: 114-13218	
2 PLC \pm 0.1		WEIGHT: -	
3 PLC \pm		SIZE: A100779	RESTRICTED TO: -
4 PLC \pm		SCALE: 4:1	SHEET: 4 OF 5
ANGLES \pm		REV: F	

