

SCREW COVER CLOSED,
AS SHOWN

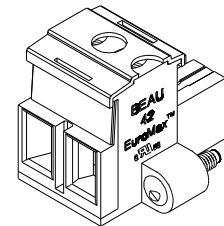

SCREW COVER CLOSED,
AS SHOWN

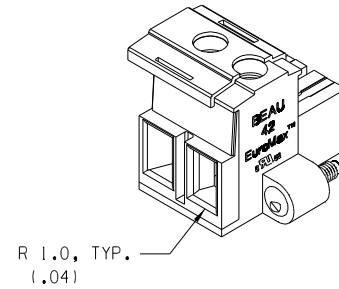
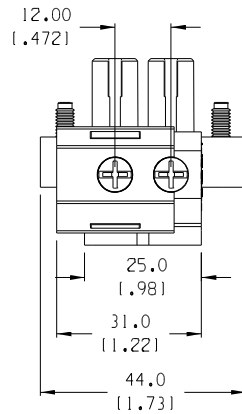
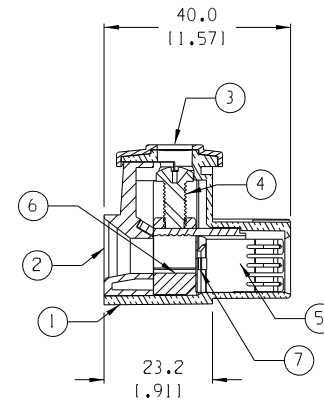
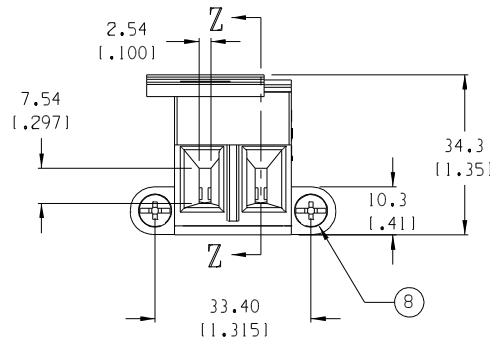

SECTION Z-Z

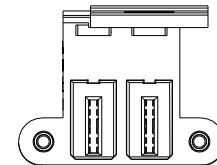

NOTES:

1. MATERIAL: SEE TABLE
2. FINISHES: SEE TABLE
3. PRODUCT SPECIFICATION: SEE PPS.42.002.DOC
4. PACKAGING: NOT REQUIRED
5. MATES WITH: 394260002 HEADER

8	2	SCREW, MTG. END, M4, PHIL-SLOT	PHOS. BRONZE	TIN
7	2	BACK PLATE	PHOS. BRONZE	TIN
6	2	PRESSURE CLAMP	BRASS	NICKEL
5	2	TERMINAL	COPPER ALLOYS	TIN
4	2	SCREW, M5 PAN HEAD, POZI-SLOT	BRONZE	TIN
3	1	SLIDING COVER	NYLON	BLACK
2	1	MOLDING COVER	PBT	BLACK
1	1	MOLDING, BODY, WITH MTG ENDS	PBT	BLACK
ITEM	QTY.	DESCRIPTION	MATERIAL	FINISH

EC NO. RELEASED
DRWN: RK 6-16-05
CHK: APPRI

MAJOR
CRITICAL
SPC
S

DESCRIPTION
REV

QUALITY SYMBOLS

GENERAL TOLERANCES:
(UNLESS SPECIFIED)

	mm	INCH
4 PLACES	±.038	±.0015
3 PLACES	±.038	±.005
2 PLACES	±.13	±.01
1 PLACE	±.3	

ANGULAR: ±2°

DRAFT WHERE APPLICABLE MUST REMAIN WITHIN DIMENSIONS

SCALE 1:1

DESIGN UNITS
 mm INCH

THIRD ANGLE PROJECTION

DRAWN BY & DATE
R. KEMP 5-17-05

CHECKED BY & DATE

APPROVED BY & DATE

CAD FILENAME
424502-SP763

MATERIAL NO.
394290002

DRAWING NO.
SD-39429-002

SHEET NO.
1 OF 1

THIS DRAWING CONTAINS INFORMATION THAT IS PROPRIETARY TO MOLEX INCORPORATED AND SHOULD NOT BE USED WITHOUT WRITTEN PERMISSION.

PROJECT NO. 05-039

DIMENSIONS:
 mm INCH mm ONLY

TITLE:
PLUG, MTG. ENDS, 12MM, 85A, 600V, #14 AWG,
2-CIRCUIT SPECIAL, W/SLIDING COVER

MOLEX INCORPORATED

SIZE B