

DO NOT
SCALE FROM
THIS PRINT

DESIGNED & DIMENSIONED
IN INCHES[MILLIMETERS]

PRF04-P-C-EP-135-SS

SERIES
-04: TNCA

GENDER
-P: PLUG

TYPE
-C: CABLE

FINISH
-EP: 50µ" EXTRA HEAVY GOLD
CENTER CONTACT, PASSIVATED
OUTER BODY

TERMINATION
-S: SOLDER CLAMP

ORIENTATION
-S: STRAIGHT

CABLE TYPE
-135: DYNAWAVE DF440W

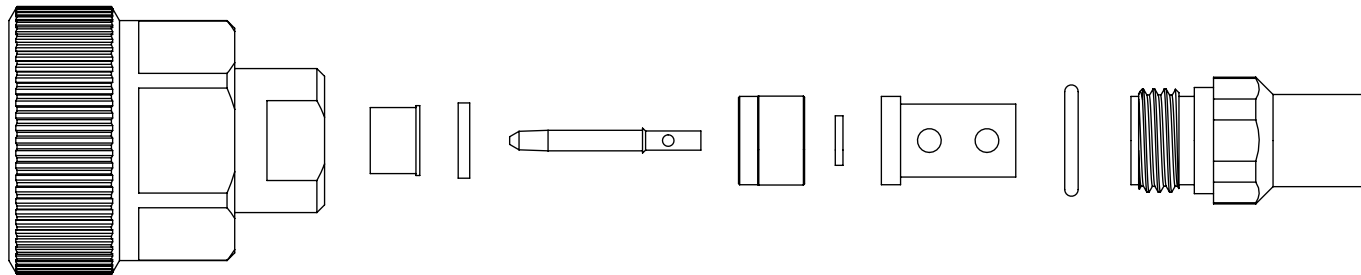
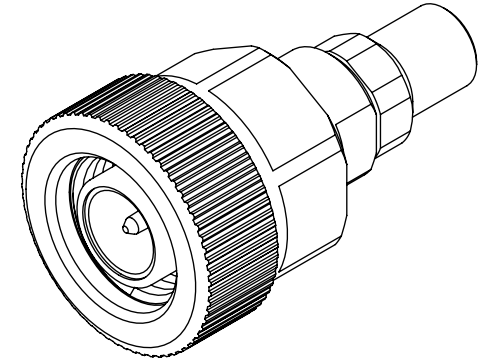
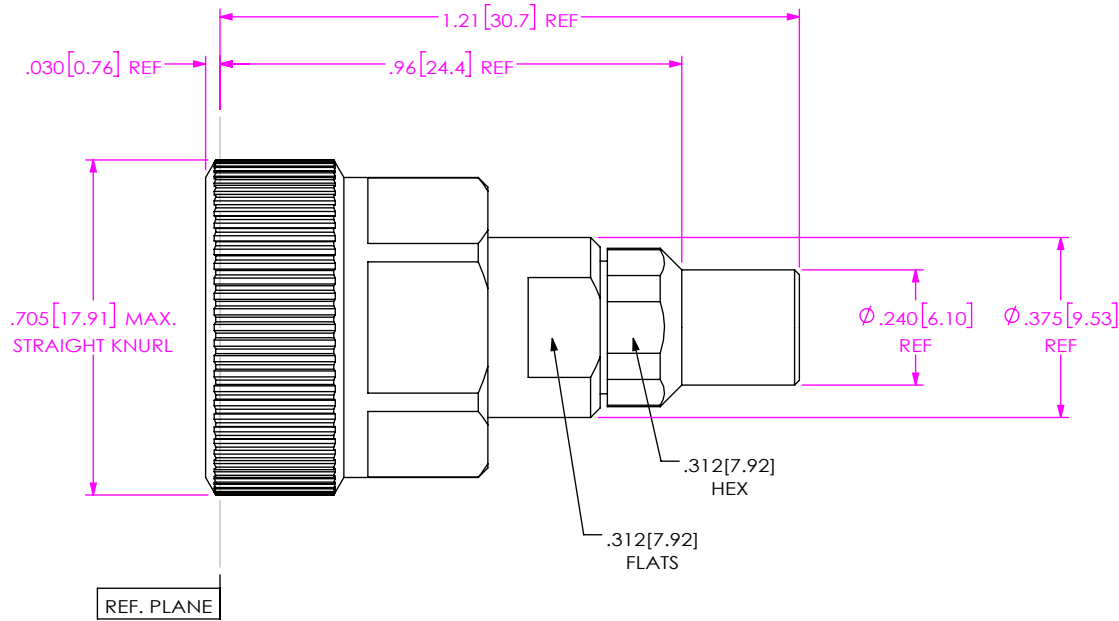

EXPLODED VIEW
NOT TO SCALE
(FOR CLARITY ONLY)

NOTES:

- MATERIAL:
BODY, COUPLING NUT, CLAMP NUT & BUSHING: STAINLESS STEEL.
CONTACT & LOCK RING: BERYLLIUM COPPER.
GASKET & O-RING: SILICONE RUBBER.
INSULATOR: TEFLON.
SOLDER FERRULE: BRASS ALLOY.
BEADS: ULTEM 1000.
- FINISH:
BODY, COUPLING NUT, CLAMP NUT & BUSHING: PASSIVATED.
CONTACT & SOLDER FERRULE: GOLD OVER NICKEL PLATE,
50 µ" MIN GOLD OVER 50 µ" MIN NICKEL.
- PCI P/N: 3748.

UNLESS OTHERWISE SPECIFIED,
DIMENSIONS ARE IN INCHES.
TOLERANCES ARE:
DECIMALS ANGLES
.XX: ±.01 [0.3] 1°
.XXX: ±.005 [0.13]
.XXXX: ±.0005 [0.013]

PROPRIETARY NOTE
THIS DOCUMENT CONTAINS CONFIDENTIAL AND PROPRIETARY INFORMATION AND ALL DESIGN, MANUFACTURING, REPRODUCTION, USE, PATENT RIGHTS AND SALES RIGHTS ARE EXPRESSLY RESERVED BY SAMTEC, INC. THIS DOCUMENT SHALL NOT BE DISCLOSED, IN WHOLE OR PART, TO ANY UNAUTHORIZED PERSON OR ENTITY NOR REPRODUCED, TRANSFERRED OR INCORPORATED IN ANY OTHER PROJECT IN ANY MANNER WITHOUT THE EXPRESS WRITTEN CONSENT OF SAMTEC, INC.



520 PARK EAST BLVD, NEW ALBANY, IN 47150
PHONE: 812-944-6733 FAX: 812-948-5047
e-Mail: info@SAMTEC.com code 55322

DO NOT SCALE DRAWING

SHEET SCALE: 2.5:1

DESCRIPTION: TNCA PLUG, SOLDER CLAMP FOR DYNAWAVE DF440W CABLE

DWG. NO. PRF04-P-C-EP-135-SS

BY: EVE L 04/12/2021 SHEET 1 OF 3

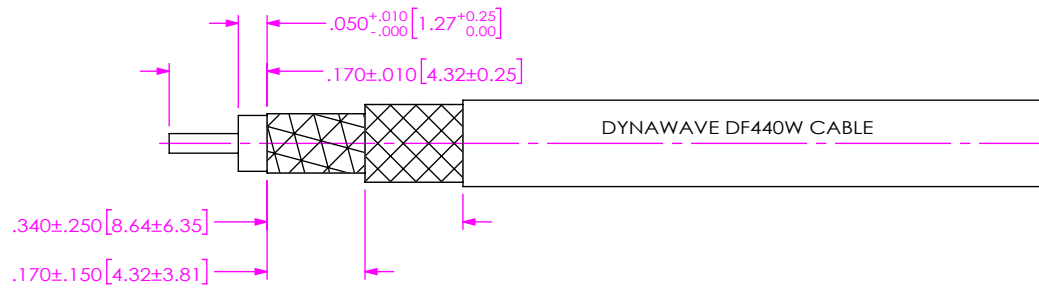

1. TRIM CABLE TO EXPOSE CENTER CONDUCTOR, DIELECTRIC AND BRAIDS AS SHOWN.

IN-PROCESS 1

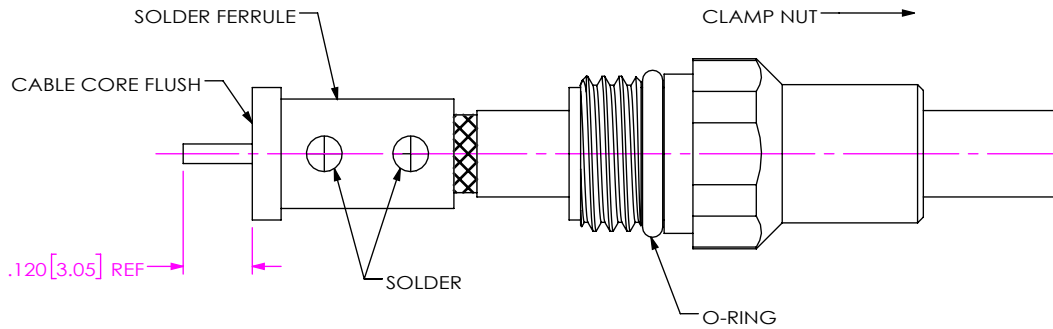

2A. INSTALL O-RING ONTO CLAMP NUT WHERE SHOWN AND SLIDE CLAMP NUT OVER CABLE IN ORIENTATION SHOWN.

2B. INSERT CABLE INTO SOLDER FERRULE UNTIL CABLE DIELECTRIC IS FLUSH WITH SOLDER FERRULE FACE AND SOLER CABLE BRAIDS WHERE SHOWN.

IN-PROCESS 2

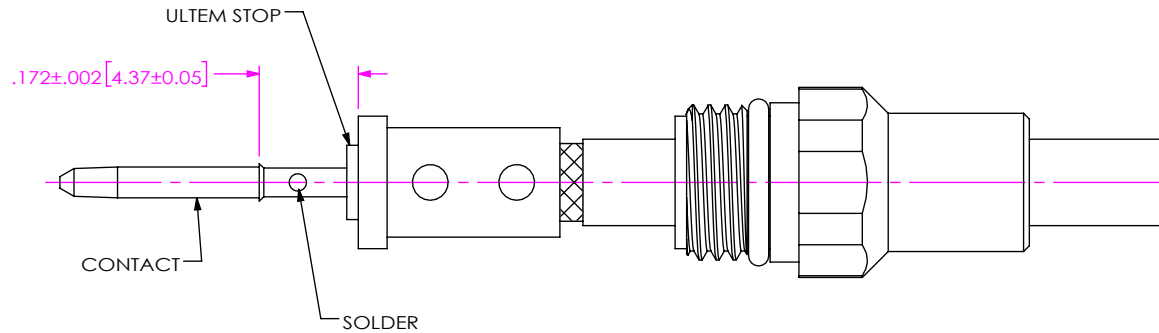

3A. INSERT ULTEM DIELECTRIC STOP OVER CABLE CENTER CONDUCTOR AGAINST SOLDER FERRULE AS SHOWN.

3B. SOLDER CONTACT FLUSH AGAINST STOP TO DIMENSION SHOWN.

IN-PROCESS 3

PROPRIETARY NOTE
 THIS DOCUMENT CONTAINS CONFIDENTIAL AND PROPRIETARY INFORMATION AND ALL DESIGN, MANUFACTURING, REPRODUCTION, USE, PATENT RIGHTS AND SALES RIGHTS ARE EXPRESSLY RESERVED BY SAMTEC, INC. THIS DOCUMENT SHALL NOT BE DISCLOSED, IN WHOLE OR PART, TO ANY UNAUTHORIZED PERSON OR ENTITY NOR REPRODUCED, TRANSFERRED OR INCORPORATED IN ANY OTHER PROJECT IN ANY MANNER WITHOUT THE EXPRESS WRITTEN CONSENT OF SAMTEC, INC.



520 PARK EAST BLVD, NEW ALBANY, IN 47150
 PHONE: 812-944-6733 FAX: 812-948-5047
 e-Mail info@SAMTEC.com code 55322

DO NOT SCALE DRAWING

SHEET SCALE: 3:1

DESCRIPTION: TNCA PLUG, SOLDER CLAMP FOR DYNAWAVE DF440W CABLE

DWG. NO. PRF04-P-C-EP-135-SS

BY: EVE L 04/12/2021 SHEET 2 OF 3

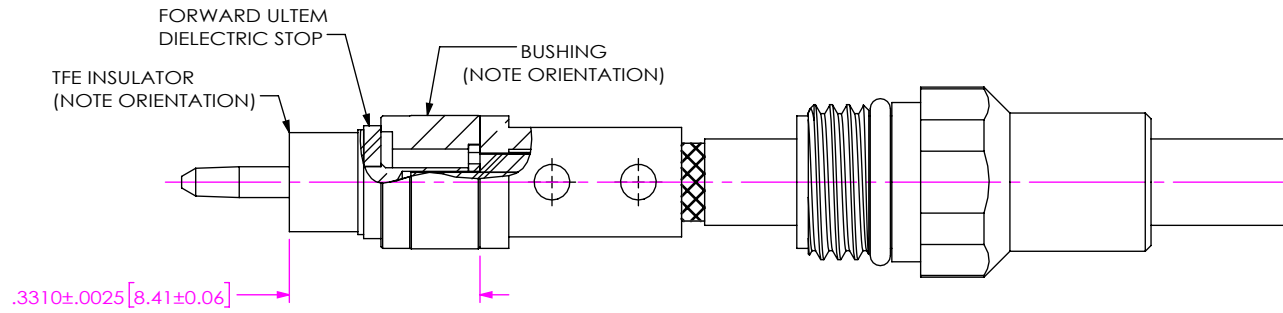

4. SLIDE BUSHING, FORWARD ULTEM STOP & FORWARD TEFLON INSULATOR OVER CONTACT AS SHOWN.

(NOTE: ORIENT BUSHING WITH SMALLER DIAMETER C'BORE TOWARD SOLDER FERRULE. ORIENT FORWARD TFE INSULATOR WITH SHOULDER TOWARD STOP.)

IN-PROCESS 4

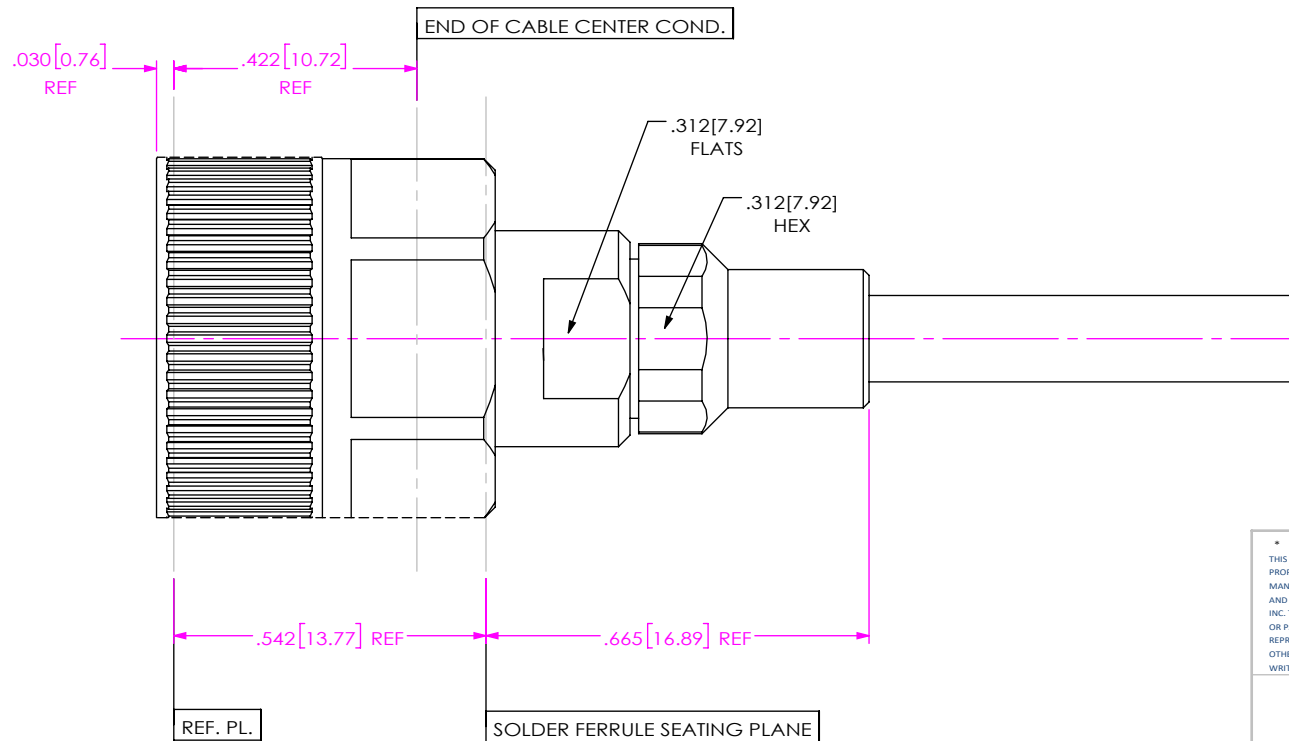

5. INSERT CABLE/CONTACT SUB-ASSEMBLY INTO CONNECTOR UNTIL SEATED AND TIGHTEN CLAMP NUT TO 35-45 IN-LBS.

IN-PROCESS 5

<p>PROPRIETARY NOTE</p> <p>THIS DOCUMENT CONTAINS CONFIDENTIAL AND PROPRIETARY INFORMATION AND ALL DESIGN, MANUFACTURING, REPRODUCTION, USE, PATENT RIGHTS AND SALES RIGHTS ARE EXPRESSLY RESERVED BY SAMTEC, INC. THIS DOCUMENT SHALL NOT BE DISCLOSED, IN WHOLE OR PART, TO ANY UNAUTHORIZED PERSON OR ENTITY NOR REPRODUCED, TRANSFERRED OR INCORPORATED IN ANY OTHER PROJECT IN ANY MANNER WITHOUT THE EXPRESS WRITTEN CONSENT OF SAMTEC, INC.</p>	 <p>520 PARK EAST BLVD, NEW ALBANY, IN 47150 PHONE: 812-944-6733 FAX: 812-948-5047 e-Mail info@SAMTEC.com code 55322</p>	
	<p>DO NOT SCALE DRAWING</p> <p>SHEET SCALE: 3:1</p>	<p>DESCRIPTION: TNCA PLUG, SOLDER CLAMP FOR DYNAWAVE DF440W CABLE</p> <p>DWG. NO. PRF04-P-C-EP-135-SS</p>
	<p>BY: EVE L</p>	<p>04/12/2021 SHEET 3 OF 3</p>