

PART NUMBER	REV	FIRST USED
466812-1	R	854400-1
466812-2	R	565435-5
466812-3	R	354500-1

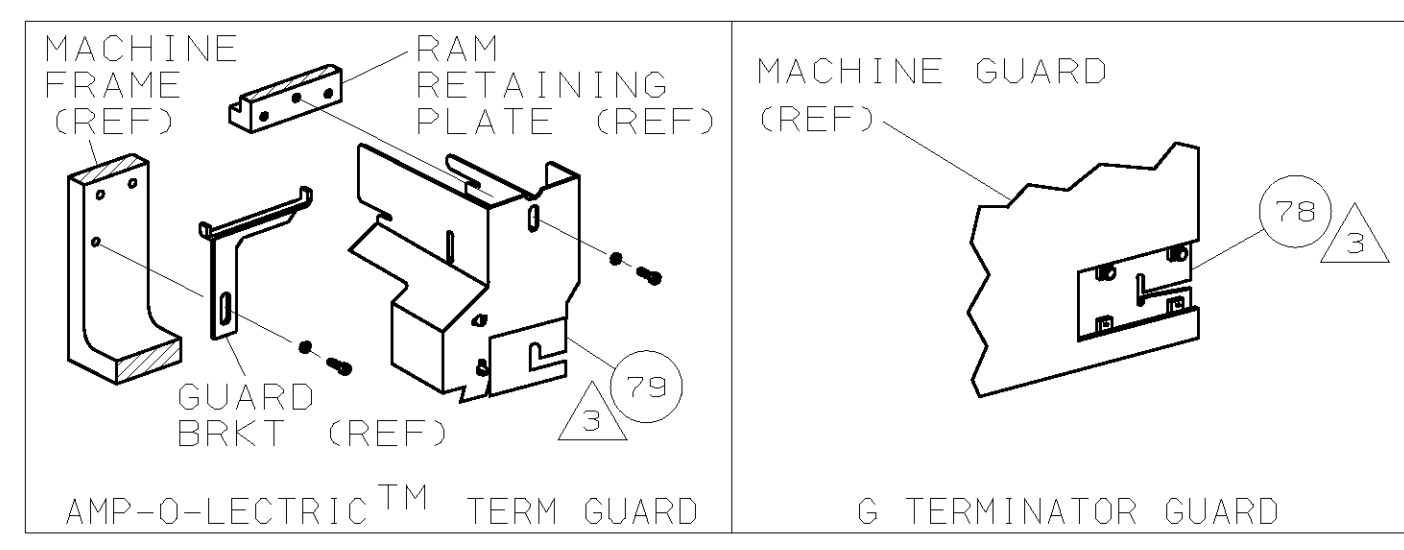
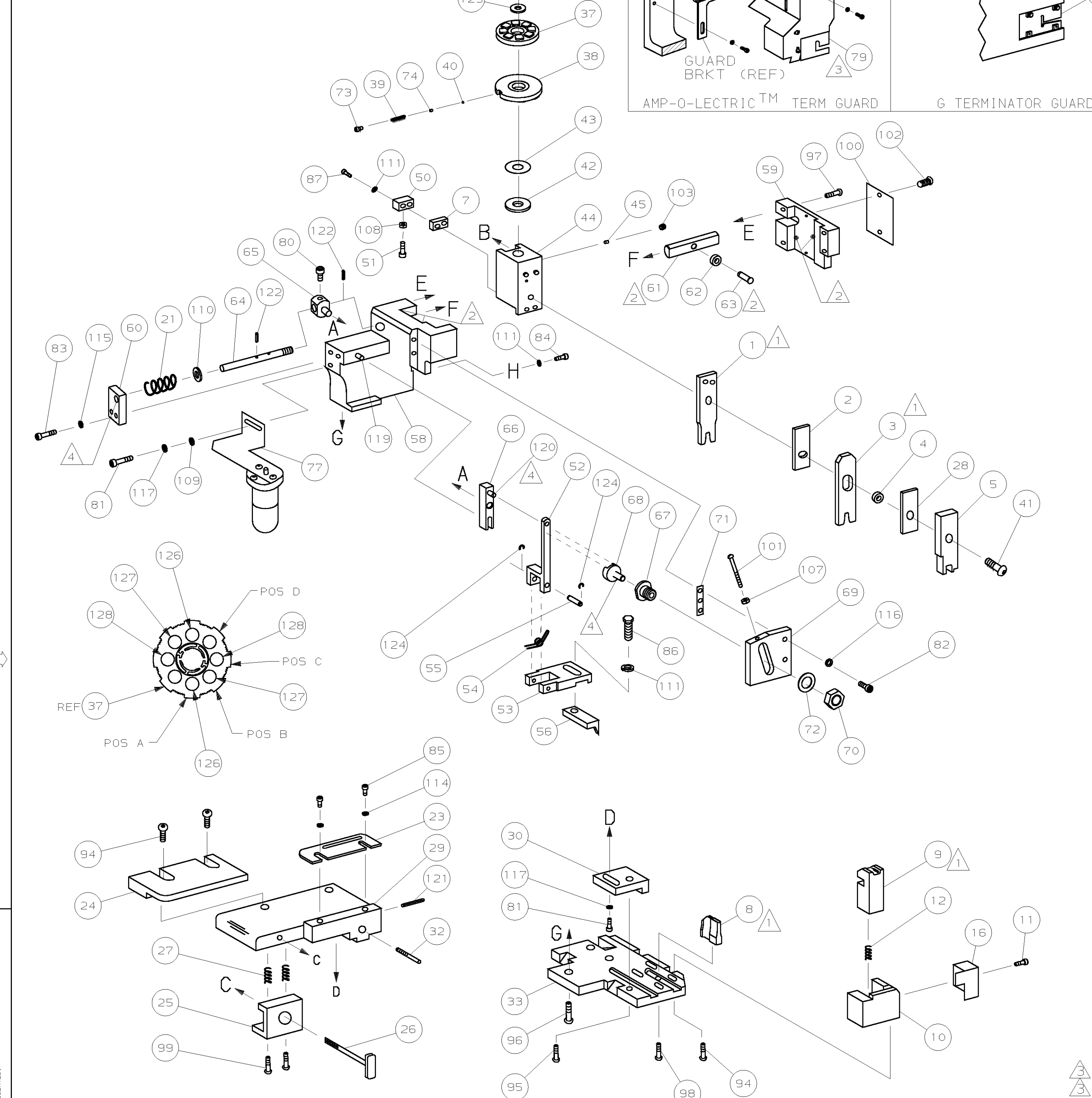

TERMINAL NAME:		CONTACT PIN MOD 1V	
	△	PIN	
		102095	
		166678	

CRIMPING DATA			
PAD LTR	CRIMP HEIGHT	WIRE SIZE	
A	.036 ±.002	22	
B	.032 ±.002	24	
C	.030 ±.002	26	
D	NOT	USED	
CRIMP	SIZE	TYPE	RANGE
WIRE	.042	F	26-22
INSUL	.062	0	.061 MAX
FEED	APPL INST	SET UP GAGE	LAYOUT
.300	408-8040	458637-1	1060
WIRE STRIP LENGTH		.109-.172	

-1		LEADMAKER		MECH POST FEED		
-2		BENCH MODEL K		MECH PRE FEED		
-3		BENCH MODEL G		MECH PRE FEED		
REF	REF	REF	-	B	22594-8	NUT, HEX (1/2-20)
REF	REF	REF	-	B	240628-1	PLATE, ADJUSTMENT
REF	REF	REF	-	B	240626-1	SHAFT, PIVOT
REF	REF	REF	-	B	240633-1	BUSHING
REF	REF	REF	-	A	455680-1	LEVER, INTERMEDIATE
REF	REF	REF	-	B	240629-1	BLOCK, PIVOT
REF	REF	REF	-	A	240632-2	SCREW, ADJ FEED ROD
REF	REF	REF	-	B	240659-3	PIN, CAM ROLLER
REF	REF	REF	-	B	240658-1	ROLLER, CAM
REF	REF	REF	-	B	454398-2	ROD, FEED
REF	REF	REF	-	A	454178-1	GUIDE, FEED ROD
REF	REF	REF	-	C	454220-1	CAP, RAM
REF	REF	REF	-	D	454485-1	HOUSING

2	2	2	-	C	6-354779-2	PIN, WIRE DISC (.3300)C	129
2	2	2	-	C	5-354779-8	PIN, WIRE DISC (.3280)B	127
2	2	2	-	C	5-354779-0	PIN, WIRE DISC (.3240)A	126
1	1	1	-	A	986950-1	WASHER, FLAT PRECISION	125
REF	REF	REF	-	A	21045-3	RING, RET "C" (Ø.187)FD FING PIN	124
REF	REF	REF	-	A	5-21028-1	PIN, SLT SPR (Ø.125x.50)ADJ ROD	122
1	1	1	-	A	4-21028-0	PIN, SLT SPR (Ø.093x.75)ST GDE PL	121
REF	REF	REF	-	A	1-21030-1	PIN, DOWEL (Ø.187x.50)LEVER	120
REF	REF	REF	-	A	1-21030-6	PIN, DOWEL (Ø.187x1.25)HOUSING	119
1	1	1	-	A	21024-5	WASHER, LOCK (#10)ADJ BLOCK	118
REF	REF	REF	-	A	21024-5	WASHER, LOCK (#10)ADJ PLATE	116
REF	REF	REF	-	A	21024-5	WASHER, LOCK (#10)FEED GDE ROD	115
2	2	2	-	A	21024-2	WASHER, LOCK (#4)FRONT STP GUIDE	114
4	4	4	-	A	21024-4	WASHER, LOCK (#8)STRIPPER	111
REF	REF	REF	-	A	21899-4	WASHER, FLAT (Ø5/16)SCREW ADJ	110
-	1	-	-	A	21899-2	WASHER, FLAT (NO.10)LUB ASSY	109
1	1	1	-	A	21018-5	NUT, HEX (6-32) HOLDDOWN	108
REF	REF	REF	-	A	21018-5	NUT, HEX (6-32)FEED ADJ	107
1	1	-	-	A	992031-1	PIN, CLEVIS	105
1	1	1	-	A	21009-2	SCR, SKT 5ET (1/4-20x.25 LW)RAM	103
2	2	2	-	A	21017-2	SCR, DRIVE (#2x.19)ID PLATE	102
REF	REF	REF	-	A	6-23715-5	SCR, PAN HD (6-32x1.50)FEED ADJ	101
1	1	1	-	B	461264-1	PLATE, IDENTIFICATION	100
2	2	2	-	A	3-21002-0	SCR, BHC (10-32x.88)DRAG	99
1	1	1	-	A	22733-8	SCR, BHC (8-32x.38 LW)ANVIL	98
REF	REF	REF	-	A	2-21002-9	SCR, BHC (10-32x.75)CAP	97
REF	REF	REF	-	A	2-22733-8	SCR, BHC (1/4-20x.62)HOUSING	96
REF	REF	REF	-	A	2-21002-7	SCR, BHC (10-32x.50)56 ADJ BLOCK	95
4	4	4	-	A	2-21002-2	SCR, BHC (8-32x.50)SHEAR	94
1	1	1	-	A	1-21002-7	SCR, BHC (6-32x.38)CAM	91
1	1	-	-	A	7-21000-9	SCR, SHC (4-40x.19)STRIPPER	89
2	2	2	-	A	2-21000-8	SCR, SHC (8-32x.63)DEP-HOLD	87
1	1	1	-	A	2-22603-1	SCR, HEX HD (8-32x.38)FEED FINGER	86
2	2	2	-	A	1-21000-3	SCR, SHC (4-40x.25)F ST GUIDE	85
1	1	1	-	A	2-21000-7	SCR, SHC (8-32x.50)STRIPPER	84
REF	REF	REF	-	A	3-21000-7	SCR, SHC (10-32x.75)FEED ROD GD	83
REF	REF	REF	-	A	3-21000-6	SCR, SHC (10-32x.62)FD ADJ BLK	82
1	2	1	-	A	3-21000-4	SCR, SHC (10-32x.38)56 ADJ BL	81
REF	REF	REF	-	A	3-21000-4	SCR, SHC (10-32x.38)PIVOT BLK	80
-	REF	-	-	B	455749-1	GUARD, WINDOW	79
REF	-	-	-	B	679532-1	INSERT, GUARD	78
-	1	-	-	C	1-465184-0	LUBRICATOR ASSY	77
1	1	1	-	A	690603-1	SPRING, ASSIST	74
1	1	1	-	A	23030-1	SCR, SHC (6-32x.25 SL)INS DISC	73
REF	REF	REF	-	A	458109-1	WASHER, SPECIAL	72
REF	REF	REF	-	A	690517-1	SPACER	71
-3	-2	-1	U/M	DWG SIZE	PART NO	DESCRIPTION	ITEM NO
QTY REOD PER ASSY							

1	1	1	-	B	458537-2	PAWL, FEED	56
REF	REF	REF	-	B	240624-1	PIN, FEED FINGER	55
REF	REF	REF	-	B	691499-1	SPRING, FEED FINGER	54
REF	REF	REF	-	B	690541-1	HOLDER, FEED FINGER	53
REF	REF	REF	-	A	455679-1	LEVER, TERMINAL FEED ARM	52
1	1	1	-	A	811242-2	BUMPER, HOLDDOWN	51
1	1	1	-	A	690753-1	SPACER, TONKER	50
1	-	-	-	B	690602-6	CAM, PRE-FEED 1 5/8 ST	49
-	1	-	-	B	690602-5	CAM, PRE-FEED 1 1/8 ST	48
-	-	1	-	B	690501-4	CAM, POST-FEED 1 5/8 ST	47
1	1	1	-	B	459456-1	APPLICATOR, BASIC (SUBASSY)	46
1	1	1	-	A	690191-1	PLUG, NYLON	45
1	1	1	-	C	455673-1	RAM	44
1	1	1	-	A	690125-1	WASHER, LAMINATED	43
1	1	1	-	A	690124-1	WASHER, RAM	42
1	1	1	-	A	7-21002-9	BOLT, CRIMPER (5/16x1.00)	41
1	1	1	-	A	23241-6	BALL, STEEL	40
1	1	1	-	A	690170-1	SPRING, COMPRESSION	39
1	1	1	-	C	690142-1	DISC, INSULATION	38
1	1	1	-	D	354777-1	WIRE DISC, PLASTIC	37
1	1	1	-	A	22480-5	WASHER, SPRING	36
1	1	1	-	B	690212-1	POST, RAM	35
1	1	1	-	B	690786-3	SUPPORT, TERMINAL	34
REF	REF	REF	-	D	455675-1	PLATE, BASE	33
							32
							31
REF	REF	REF	-	B	455689-1	BLOCK, STRIP GUIDE ADJ	30
1	1	1	-	C	455671-5	PLATE, STRIP GUIDE	29
1	1	1	-	C	1-455888-3	SPACER, FRONT SHEAR DEP	28
2	2	2	-	A	1-22284-0	SPRING, DRAG	27
1	1	1	-	B	690546-1	LEVER, DRAG RELEASE	26
1	1	1	-	B	240792-1	DRAG, TERMINAL	25
1	1	1	-	D	7-690504-5	GUIDE, STRIP (REAR)	24
1	1	1	-	A	690438-1	GUIDE, STRIP (FRONT)	23
-	-	1	-	B	690472-2	STRIPPER	22
REF	REF	REF	-	A	4-22284-9	SPRING, FEED RETURN	21
1	1	-	-	A	679218-1	STRIPPER WIRE STOP ASSY	20
1	1	-	-	B	458949-1	STRIPPER	19
							18
							17
1	1	1	-	B	691667-1	GUARD, CHIP (FRONT)	16
							15
							14
							13
1	1	1	-	A	5-22280-0	SPRING, SHEAR	12
1	1	1	-	B	690461-1	STOP, SHEAR	11
1	1	1	-	C	690459-1	HOLDER, SHEAR (FRONT)	10
1	1	1	-	C	462006-1	SHEAR, FLOAT (FRONT)	9
1	1	1	-	C	2-683403-6	ANVIL	8
1	1	1	-	C	240641-3	SPACER, DEPRESSOR (REAR)	7
							6
1	1	1	-	C	2-455889-0	DEPRESSOR, SHEAR (FRONT)	5
1	1	1	-	B	1-238011-3	SPACER, BLOCK CRIMPER	4
1	1	1	-	C	7-456135-8	CRIMPER, INSULATION	3
1	1	1	-	C	455888-6	SPACER, CRIMPER	2
1	1	1	-	C	456401-3	CRIMPER, WIRE	1
-3	-2	-1	U/M	DWG SIZE	PART NO	DESCRIPTION	ITEM NO
QTY REOD PER ASSY							

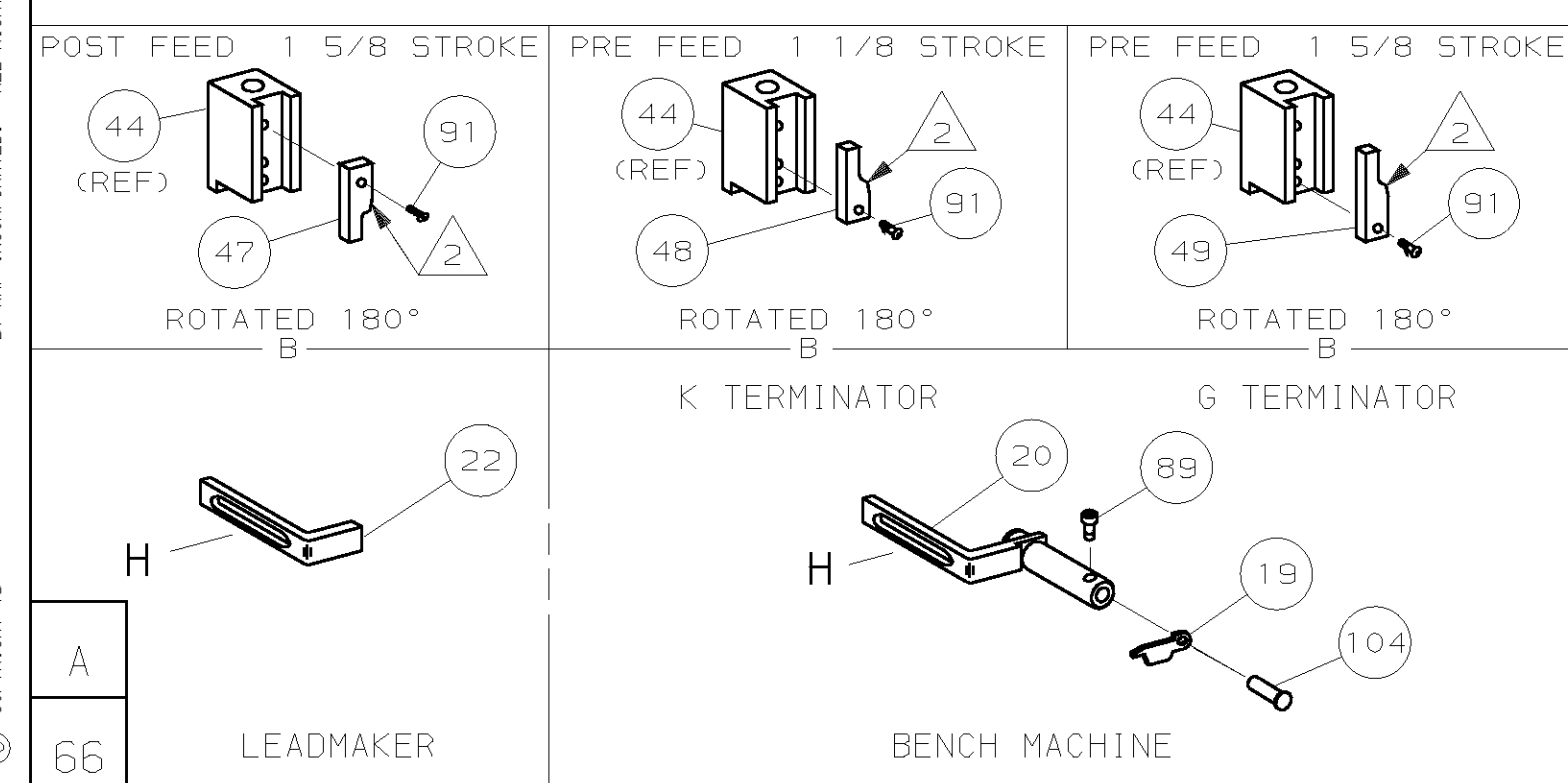

- △ 1 RECOMMENDED SPARE PARTS.
- △ 2 GREASE LIGHTLY.
- △ 3 GUARD MUST BE IN PLACE WHEN OPERATING APPLICATOR IN A BENCH MACHINE.
- △ 4 LUBRICATE DAILY USING NO. 20 MACHINE OIL.
- △ 5. ITEMS WITH QTY OF REF SPECIFIED (EXCEPT ITEMS 78 AND 79) ARE USED ON ITEM 46.
- △ 6 LUBRICATION REQUIRED TO RUN THIS PRODUCT.

THIS DRAWING IS A CONTROLLED DOCUMENT.

.JIS

RELEASED FOR PUBLICATION
BY AMP INCORPORATED. ALL RIGHTS RESERVED.

THIS DRAWING IS UNRELEASED.
COPYRIGHT 19

DIMENSIONS IN INCHES. DO NOT SCALE PRINT. TOLERANCES UNLESS OTHERWISE SPECIFIED:
2 PLC DEC ±
3 PLC DEC ±
4 PLC DEC ±
ANGLES ± -
SURF TEXTURE: ✓
REMOVE BURRS, BREAK SHARP EDGES R.015 MAX

MATL - HT TR - FIN -

DR 11/15/94 APP 11-16-94 T.BEDDICK
D.SALTZER
CHK 11-16-94 REL 12/6/94 B. MORGAN
C.ERISMAN

AMP Incorporated
Harrisburg, PA 17105-3608

NAME SIDE FEED HDM APPLICATOR MACHINE REF
SCALE - DWG NO 466812 SHEET 1 OF 1 REV R

CASE CODE 00779 CUSTOMER AND ASSEMBLY DRAWING RESTRICTED TO