

LOW DROPOUT VOLTAGE REGULATOR

■ GENERAL DISCRIPTION

NJU7741/44 is a low dropout voltage regulator with ON/OFF control and Output shunt switch.

Advanced CMOS technology achieves high ripple rejection and ultra low quiescent current.

It is suitable for reset small micro controller and other logic chips.

NJU7744 features shunt switch which improves turn off response of output voltage when ON/OFF control is used.

■ PACKAGE OUTLINE

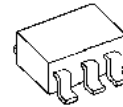

NJU7741/44F

■ FEATURES

- Ultra Low quiescent Current $I_q=1.5\mu\text{A typ.}(I_o=0\text{mA})$
- Output capacitor with 0.1 μF ceramic capacitor
- Output Current $I_o(\text{max.})=100\text{mA}$
- High Precision Output $V_o\pm 1.0\%$
- Low Dropout Voltage 0.17V typ. ($I_o=60\text{mA}$, $V_o=3\text{V}$ version)
- With ON/OFF Control (Active High)
- With Output Shunt Switch Only NJU7744
- Internal Short Circuit Current Limit
- CMOS Technology
- Package Outline SOT-23-5

■ PIN CONFIGURATION

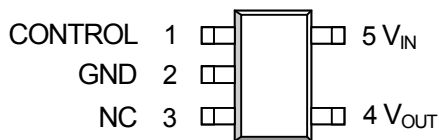

NJU7741/44F

■ BLOCK DIAGRAM

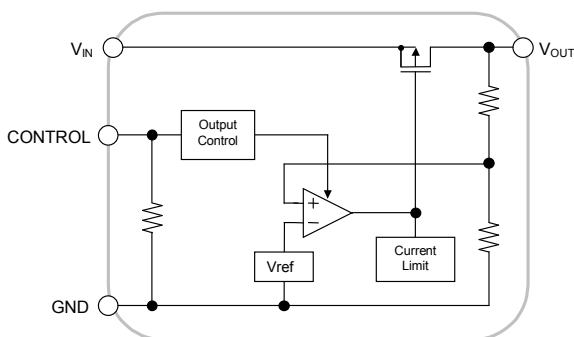

NJU7741

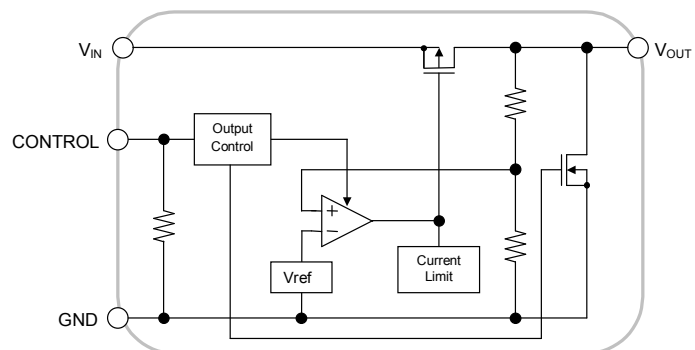

NJU7744

NJU7741/44

■ OUTPUT VOLTAGE RANK LIST

DEVICE NAME	V _{OUT}	DEVICE NAME	V _{OUT}	DEVICE NAME	V _{OUT}
NJU774*F15	1.5V	NJU774*F28	2.8V	NJU774*F04	4.0V
NJU774*F18	1.8V	NJU774*F29	2.9V	NJU774*F45	4.5V
NJU774*F19	1.9V	NJU774*F03	3.0V	NJU774*F05	5.0V
NJU774*F02	2.0V	NJU774*F31	3.1V	NJU774*F06	6.0V
NJU774*F25	2.5V	NJU774*F33	3.3V		
NJU774*F27	2.7V	NJU774*F37	3.7V		

■ ABSOLUTE MAXIMUM RATINGS (Ta=25°C)

PARAMETER	SYMBOL	RATINGS	UNIT
Input Voltage	V _{IN}	+10	V
Control Voltage	V _{CONT}	+10(*1)	V
Power Dissipation	P _D	SOT-23-5 380(*2) 510(*3)	mW
Operating Temperature	T _{opr}	-40 ~ +85	°C
Storage Temperature	T _{stg}	-40 ~ +125	°C
Output Sink Current at OFF-state(*4)	I _o	10	mA

(*1) : When input voltage is less than +10V, the absolute maximum control voltage is equal to the input voltage.

(*2) : Mounted on glass epoxy board. (76.2 × 114.3 × 1.6mm:based on EIA/JDEC standard, 2Layers)

(*3) : Mounted on glass epoxy board. (76.2 × 114.3 × 1.6mm:based on EIA/JDEC standard, 4Layers), internal Cu area: 74.2x74.2mm

(*4) : This maximum rating is applied to NJU7744.

■ ELECTRICAL CHARACTERISTICS (V_{IN}=V_O+1V, C_{IN}=0.1μF, C_O=0.1μF, Ta=25°C)

PARAMETER	SYMBOL	TEST CONDITION	MIN.	TYP.	MAX.	UNIT	
Output Voltage	V _O	I _o =30mA	-1.0%	-	+1.0%	V	
Input Voltage	V _{IN}		-	-	9	V	
Quiescent Current	I _Q	I _o =0mA, V _{CONT} =V _{IN} , Except I _{CONT}	-	1.5	3.5	μA	
Quiescent Current at Control OFF	I _{Q(OFF)}	V _{CONT} =0V	-	0.1	1	μA	
Output Current	I _o	V _O -0.3V	100	-	-	mA	
Short Circuit Limit	I _{LIM}	V _O =0V	-	25	-	mA	
Line Regulation	ΔV _O /ΔV _{IN}	V _{IN} =V _O +1V~V _O +6.0V(V _O <3.0V) V _{IN} =V _O +1V~9.0V(V _O ≥3.0V), I _o =30mA	-	-	0.30	%/V	
Load Regulation	ΔV _O /ΔV _O	I _o =0~100mA	-	-	0.15	%/mA	
Dropout Voltage	ΔV _{I-O}	I _o =40mA	1.5V≤V _O ≤2.0V	-	0.19	0.60	V
		I _o =60mA	2.0V≤V _O ≤2.4V	-	0.19	0.29	V
			2.5V≤V _O ≤2.7V	-	0.18	0.27	V
			2.8V≤V _O ≤3.3V	-	0.17	0.26	V
			3.4V≤V _O ≤5.0V	-	0.16	0.24	V
			5.1V≤V _O ≤6.0V	-	0.15	0.22	V
Average Temperature Coefficient of Output Voltage	ΔV _O /ΔTa	Ta=0~85°C, I _o =10mA	-	±100	-	ppm/°C	
Pull-down Resistance	R _{CONT}		2	5	10	MΩ	
Control Voltage for ON-State	V _{CONT(ON)}		1.6	-	V _{IN}	V	
Control Voltage for OFF-State	V _{CONT(OFF)}		0	-	0.3	V	
Pull-down Resistance at OFF-state(note 5)	R _{O(OFF)}	V _{CONT} =0V (V _O =3.0V Version)	-	300	-	Ω	

(*5) This electrical characteristics is applied to NJU7744.

The above specification is a common specification for all voltages.

Therefore, it may be different from the individual specification for a specific output Voltage.

■ THERMAL CHARACTERISTICS

PARAMETER	SYMBOL	VALUE	UNIT
Junction-to-ambient thermal resistance	θ_{ja}	260(*6) 195(*7)	$^{\circ}\text{C}/\text{W}$
Junction-to-Top of package characterization parameter	ψ_{jt}	70(*6) 60(*7)	$^{\circ}\text{C}/\text{W}$

(*6) : Mounted on glass epoxy board. (76.2 × 114.3 × 1.6mm:based on EIA/JDEC standard, 2Layers)

(*7) : Mounted on glass epoxy board. (76.2 × 114.3 × 1.6mm:based on EIA/JDEC standard, 4Layers), internal Cu area: 74.2x74.2mm

■ POWER DISSIPATION vs. AMBIENT TEMPERATURE

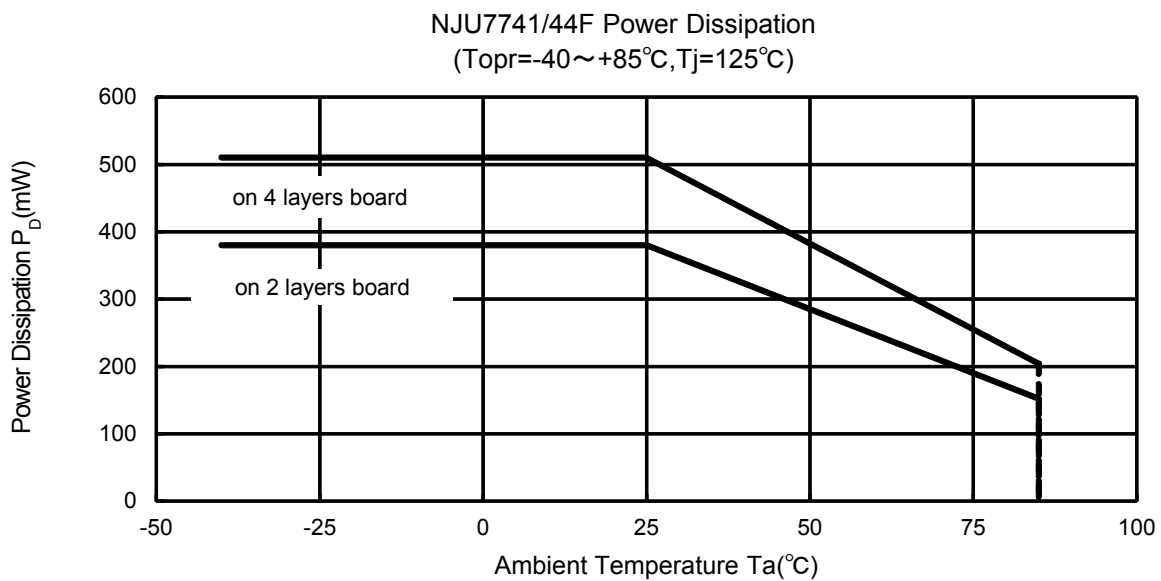

■ TEST CIRCUIT

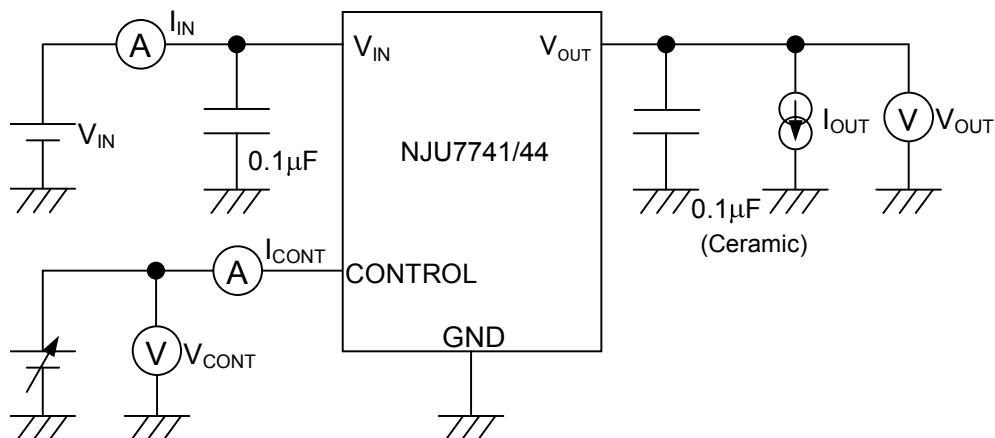

■ TYPICAL APPLICATION

① In case that ON/OFF Control is not required:

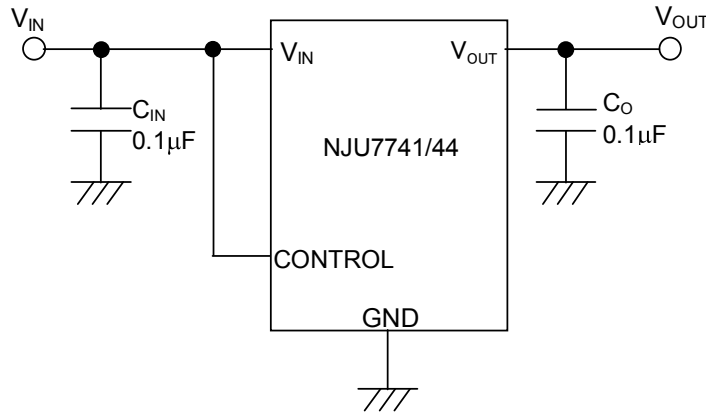

Connect control terminal to V_{IN} pin.

② In use of ON/OFF Control

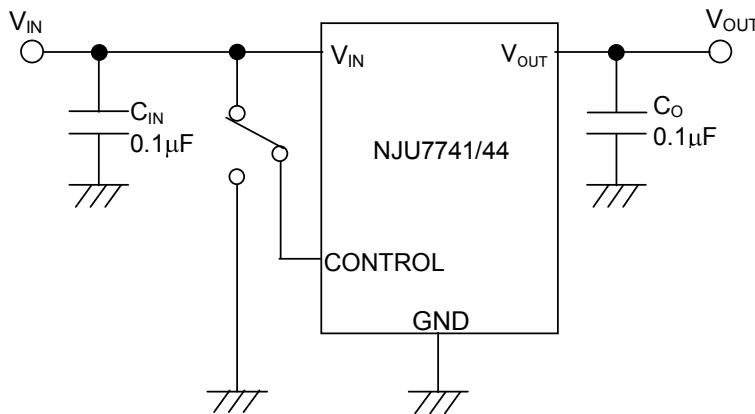

State of control pin:

- "H" → output is enabled.
- "L" or "open" → output is disabled.

*Transient response characteristic of Output Voltage

In general, overshoot or undershoot of output voltage may occur due to the transient response characteristic of an internal error amplifier.

Especially, low current consumption regulator may have overshoot or undershoot due to slow feedback caused by current saving design.

Therefore, design validation is important in the following cases:

1. Input voltage or output current change sharply
2. Output capacitors is small
3. Output load is light
4. A regulator starts up with very low dropout voltage operation.

Increasing the value of input and/or output capacitor is a common countermeasure for improving a transient response characteristic.

A transient response characteristic may vary with operating conditions and external components value.

Please check it with the actual environment.

*Input Capacitor C_{IN}

The input capacitor C_{IN} is required to prevent oscillation and reduce power supply ripple for applications when high power supply impedance or a long power supply line.

Therefore, use the recommended C_{IN} value (refer to conditions of ELECTRIC CHARACTERISTIC) or larger and should connect between GND and V_{IN} as shortest path as possible to avoid the problem

*Output Capacitor C_O

The output capacitor C_O will be required for a phase compensation of the internal error amplifier.

The capacitance and the equivalent series resistance (ESR) influence to stable operation of the regulator.

Use of a smaller C_O may cause excess an output noise or an oscillation of the regulator due to lack of the phase compensation.

On the other hand, use of a larger C_O reduces an output noise and a ripple output, and also improves an output transient response when a load rapidly changes.

Therefore, use the recommended C_O value (refer to conditions of ELECTRIC CHARACTERISTIC) or larger and should connect between GND and V_{OUT} as shortest path as possible for stable operation

The recommended capacitance depends on the output voltage rank. Especially, a low voltage regulator requires larger C_O value.

NJU7741/44

TYPICAL CHARACTERISTICS

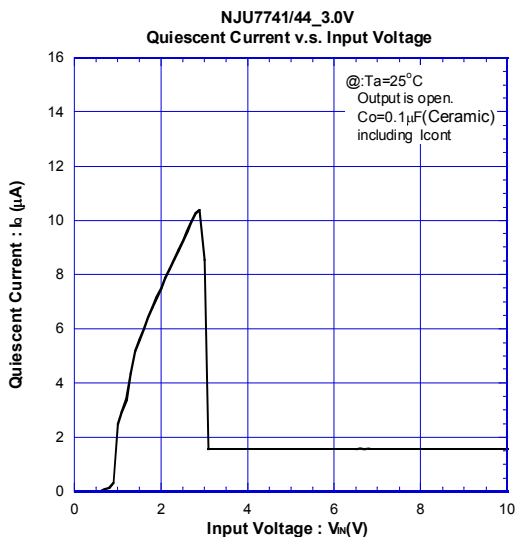
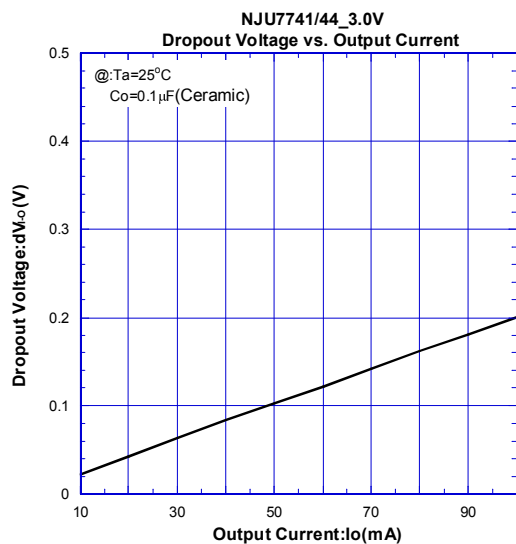
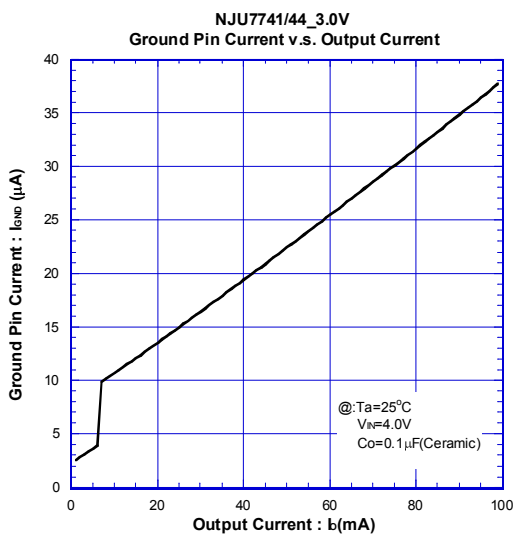
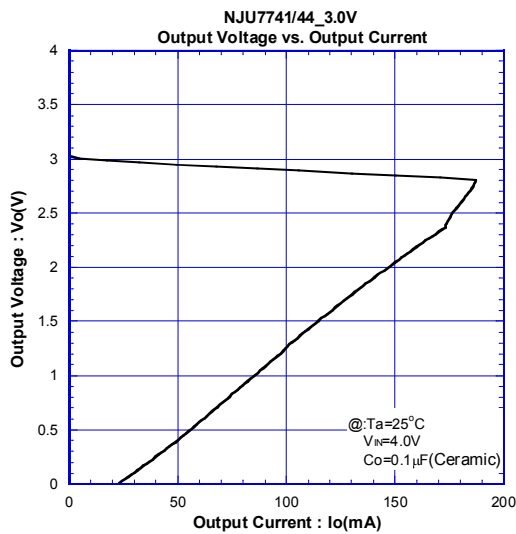
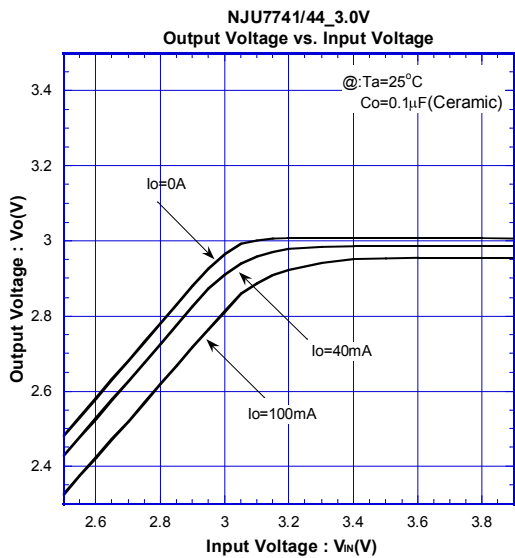

TYPICAL CHARACTERISTICS

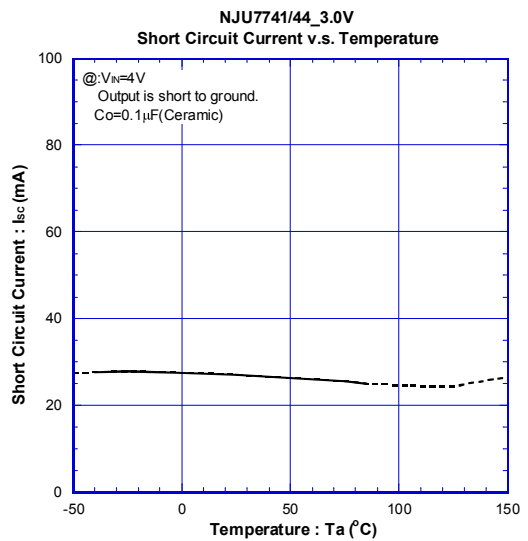
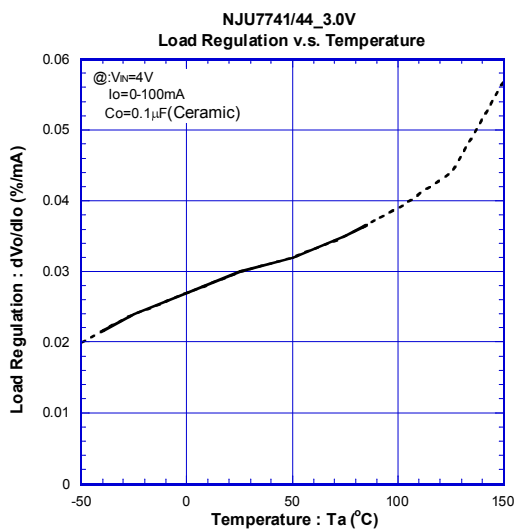
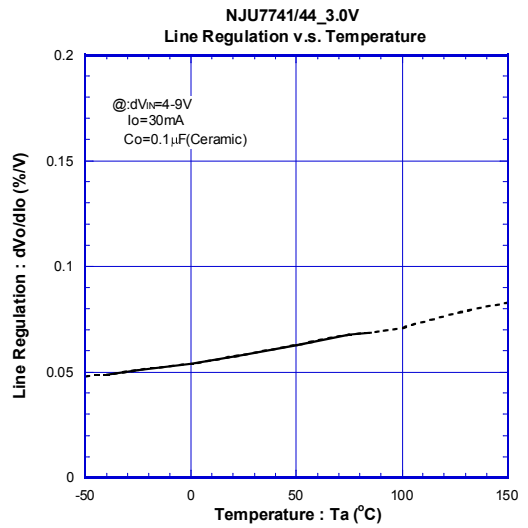
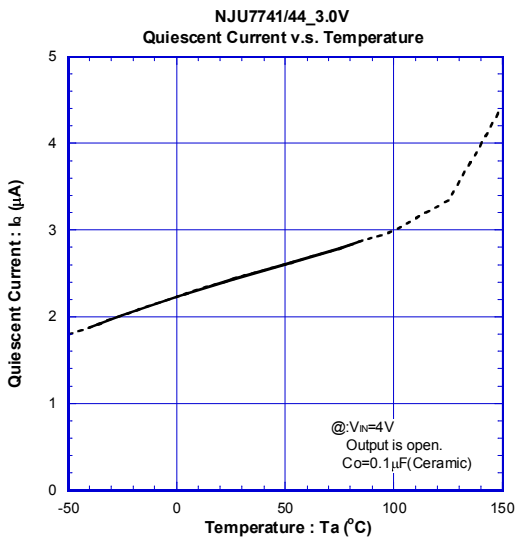
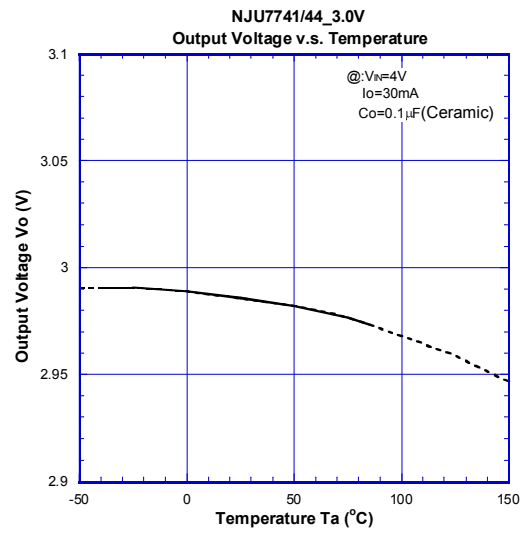
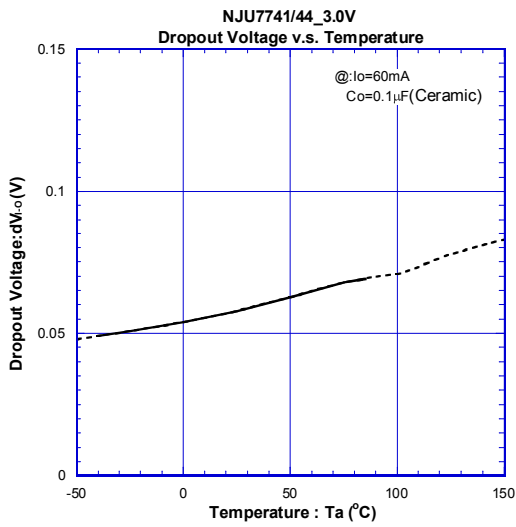

[CAUTION]

The specifications on this databook are only given for information, without any guarantee as regards either mistakes or omissions. The application circuits in this databook are described only to show representative usages of the product and not intended for the guarantee or permission of any right including the industrial rights.