

PART NUMBER	REVISION	DESCRIPTION	FEED TYPE
2266164-2	D	FINE CRIMP HEIGHT ADJUST	PNEUMATIC
7-2266164-2	D	PNEUMATIC AND CRIMP TOOLING KIT	PNEUMATIC
7-2266164-7	C	CRIMP TOOLING KIT	-

ATLANTIC VERSION TERMINATOR INTERFACE ADAPTER

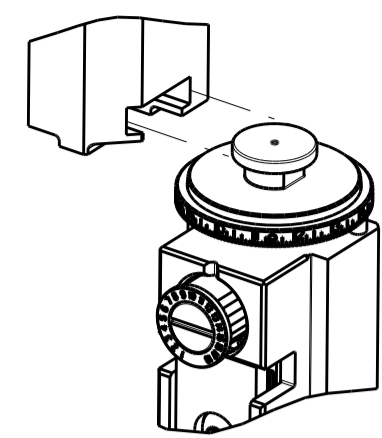

APPLICATOR DATA		
CRIMP	SIZE	TYPE
WIRE	5.50 mm [.217]	F
INSUL	6.90 mm [.272]	OV

APPLICATOR INSTRUCTIONS 408-35042

TERMINAL DATA: TE TERMINAL		TE CRIMP SPECIFICATION	
TERMINAL NAME: CLIP 8 mm NG1 CAPACITE 7 A 10 mm2			
WIRE STRIP LENGTH		INSULATION DIAMETER RANGE	
7.00-7.00 mm [.276-.276 IN]		Ø4.90-6.00 mm [.193-.236 IN]	
TERMINAL APPLICATION SPECIFICATION	Proner Comate1 2398 C 002		
TERMINALS APPLIED			
TE TERMINAL	TE TERMINAL	TE SEAL	TE SEAL
1544228-1			

TERMINAL DATA: TE TERMINAL		TE CRIMP SPECIFICATION	
TERMINAL NAME: CLIP 8 mm NG1 CAPACITE 7 A 10 mm2			
WIRE STRIP LENGTH		INSULATION DIAMETER RANGE	
7.00-7.00 mm [.276-.276 IN]		Ø4.90-6.00 mm [.193-.236 IN]	
TERMINAL APPLICATION SPECIFICATION			
TERMINALS APPLIED			
TE TERMINAL	TE TERMINAL	TE SEAL	TE SEAL
1544228-1			

WIRE SIZE	CRIMP HEIGHT mm [INCH]	CRIMP HEIGHT REFERENCE SETTING
10.18mm2	3.52+/-0.05 [.139+/- .002]	5.5
10.05mm2	3.52+/-0.05 [.139+/- .002]	5.5
7.42mm2	3.20+/-0.05 [.126+/- .002]	8.5
7.26mm2	3.18+/-0.05 [.125+/- .002]	8.7

WIRE SIZE	CRIMP HEIGHT mm [INCH]	CRIMP HEIGHT REFERENCE SETTING
10.00mm2	3.52+/-0.05 [.139+/- .002]	5.5

- 1 RECOMMENDED SPARE PARTS
- 2 REFER TO SUPPLIED INSTRUCTION SHEET FOR CLEANING, LUBRICATION AND STORAGE OF APPLICATOR.
- 3 APPLY PART NUMBER 2-23419-6 LOCTITE TO THREADS OF ITEM 242.
- 4 CRIMP HEIGHT REFERENCE SETTING WAS THE SETTING USED WHEN THE APPLICATOR WAS QUALIFIED AT THE FACTORY. ADJUSTMENT MAY BE NECESSARY WHEN RUNNING APPLICATOR IN THE FIELD.
- 5. UNLESS SPECIFIED OTHERWISE TORQUE VALUES SHALL BE USED PER DOCUMENT, 101-35000.
- 6 WIRE SIZE OVER 10mm2 IS NOT RECOMMENDED, PLS CHECK PRESS COMPATIBILITY OF TERMINATOR.
- 7 TERMINAL PITCH NOT COMPATIBLE WITH MECHANICAL FEED.
- 8 THIS CRIMP PARAMETER IS PROVIDED TO MEET A CUSTOM AND UNIQUE CUSTOMER REQUIREMENT. IT HAS BEEN EVALUATED AND IS CONDITIONALLY SPECIFIED BY TE CONNECTIVITY. THIS CUSTOMIZED CRIMP PARAMETER IS NOT LISTED AS AN APPROVED APPLICATION WITHIN A TE CONNECTIVITY APPLICATION SPECIFICATION. **TE CONNECTIVITY EXPRESSLY DISCLAIMS ANY AND ALL WARRANTIES THAT THE PRODUCT WILL PERFORM SIMILARLY TO VALIDATED AND APPROVED APPLICATIONS, AS STATED WITHIN TE CONNECTIVITY APPLICATION SPECIFICATIONS, INCLUDING BUT NOT LIMITED TO IMPLIED WARRANTIES OF MERCHANTABILITY OR FITNESS FOR PARTICULAR PURPOSE.** AS SUCH, IT IS HIGHLY RECOMMENDED THAT THE CUSTOMER PERFORM FURTHER DETAILED EVALUATION TO ASSESS PRODUCT PERFORMANCE IN THE SPECIFIC APPLICATION.

***WARNING**
ON INSTALLATION, SET WIRE DISC TO CRIMP HEIGHT REFERENCE SETTING FOR LARGEST WIRE SIZE. CRIMP HEIGHT REFERENCE SETTINGS GREATER THAN THE VALUE SHOWN MAY CAUSE DAMAGE TO THE CRIMP TOOLING, REFER TO THE INSTRUCTION SHEET FOR PROPER SETUP AND ADJUSTMENTS.

LOC	DIST	REV	DATE	BY	CHK	APP'D
A	66	A	22JAN2014	KH		UG
		B	06MAR2014	YY		UG
		C	25APR2017	TB		CT
		D	12OCT2019	FZ		TE

-	1	1	455888-1	SPACER, CRIMPER	261
-	1	1	2119641-1	FEED CAM, AIR FEED	248
-	1	1	2119082-7	CAM, SNAIL, INSULATION ADJUSTMENT	244
-	1	1	2079764-1	WASHER, WAVE SPRING, CREST-TO-CREST	243
-	1	1	2119083-1	RETAINER, INSULATION DIAL	242
-	1	1	2844940-2	AIR FEED MODULE	238
-	REF	REF	994970-2	COUNTER, MAGNETIC	164
-	1	1	1-18028-2	WASHER, FLAT, REG M4	119
-	1	1	2844908-1	SCREW, LOCKING	99
-	1	1	2844907-1	POST, LOCKING	98
-	1	1	1-690438-0	FRONT STRIP GUIDE	96
-	1	1	455888-5	SPACER, CRIMPER	82
-	2	2	1-2079383-8	SCR, BHSC, RoHS (M4 X 6)	79
-	1	1	1803096-1	EXTENSION PLATE	78
-	1	1	1803607-3	DOCUMENTATION PACKAGE	71
-	1	1	2119791-5	DEPRESSOR, WIRE	70
-	1	1	2119943-1	WASHER, SPACER	69
-	1	1	2119740-1	TAG IDENTIFICATION	67
-	2	2	2168078-1	SCREW, DRIVE, RH, RoHS, 2 x .188	66
-	1	1	2168083-2	SCR, SKT HD CAP, RoHS, M4 X 8.0	60
-	1	1	5-18022-5	SCR, HEX HD CAP, M4 X 6.0	59
-	1	1	1-1338683-1	FEED PAWL	56
-	4	4	2168083-3	SCR, SKT HD CAP, RoHS, M4 X 12.0	54
-	2	2	1-2168083-0	SCR, SKT HD CAP, RoHS, M4 X 10	53
-	1	1	5018030-1	NUT, HEX, REG, RoHS, M3	52
-	1	1	811242-5	BUMPER, HOLD DOWN	51
-	1	1	690753-2	SPACER, TONKER	50
-	1	1	18023-9	SCR, SKT HD CAP M4 X 6.0	49
-	1	1	1-1803583-7	APPLICATOR BASIC ASSEMBLY, SF	46
-	1	1	1803515-2	RAM ASSEMBLY, SF ATLANTIC	44
-	1	1	1803602-2	SCR, BHSC, RoHS (M8 X 40)	41
-	1	1	1752356-2	SUPPORT, TERMINAL	34
-	2	2	2079383-5	SCR, BHSC, RoHS (M4 X 20)	33
-	2	2	2-2844962-6	SPACER, CYLINDRICAL, STRIP GUIDE	30
-	1	1	2844992-5	ASSEMBLY, STRIP GUIDE	29
-	1	1	455888-3	SPACER, CRIMPER	28
-	2	2	22281-8	SPRING, COMPRESSION	27
-	1	1	240792-1	DRAG, TERMINAL	25
-	1	1	1320928-6	STRIP GUIDE	24
-	1	1	2168083-2	SCR, SKT HD CAP, RoHS, M4 X 8.0	21
-	1	1	1-18028-2	WASHER, FLAT, REG M4	20
-	1	1	2119533-1	STRIPPER, SIDE FEED	19
-	1	1	3-22280-3	SPRING, COMPRESSION	12
-	1	1	1-356885-3	STOP, SHEAR	11
-	1	1	1-2119805-2	SHEAR HOLDER, FRONT	10
-	1	1	1-318059-0	FLOATING SHEAR, FRONT	9
1	2	1	7-1633930-7	ANVIL, COMBINATION	8
-	-	-	-	-	7
-	-	-	-	-	6
-	1	1	1803080-1	DEPRESSOR, SHEAR	5
-	1	1	4-238011-4	BLOCK, CRIMPER SPACER	4
1	2	1	1803462-1	CRIMPER, INSULATION OVERLAP PREMIUM	3
-	1	1	1-455888-2	SPACER, CRIMPER	2
1	2	1	8-1490019-3	CRIMPER, WIRE PREMIUM	1

DIMENSIONS:		TOLERANCES UNLESS OTHERWISE SPECIFIED:		DRAWING NO.	
mm	0 PLC ±	1 PLC ±	2 PLC ±	3 PLC ±	4 PLC ±
	ANGLES				
MATERIAL	FINISH	WEIGHT	SCALE	SHEET	REV
			1:2	1 OF 4	D

ATLANTIC VERSION
Shown on sheets 1 of 4 & 2 of 4
(Pacific version shown on sheets 3 of 4 & 4 of 4)

LOC		DIST		REVISIONS			
A	66	P	LTM	DESCRIPTION	DATE	DWN	APVD
		-		SEE SHEET 1			

FEED TYPE

PNEUMATIC

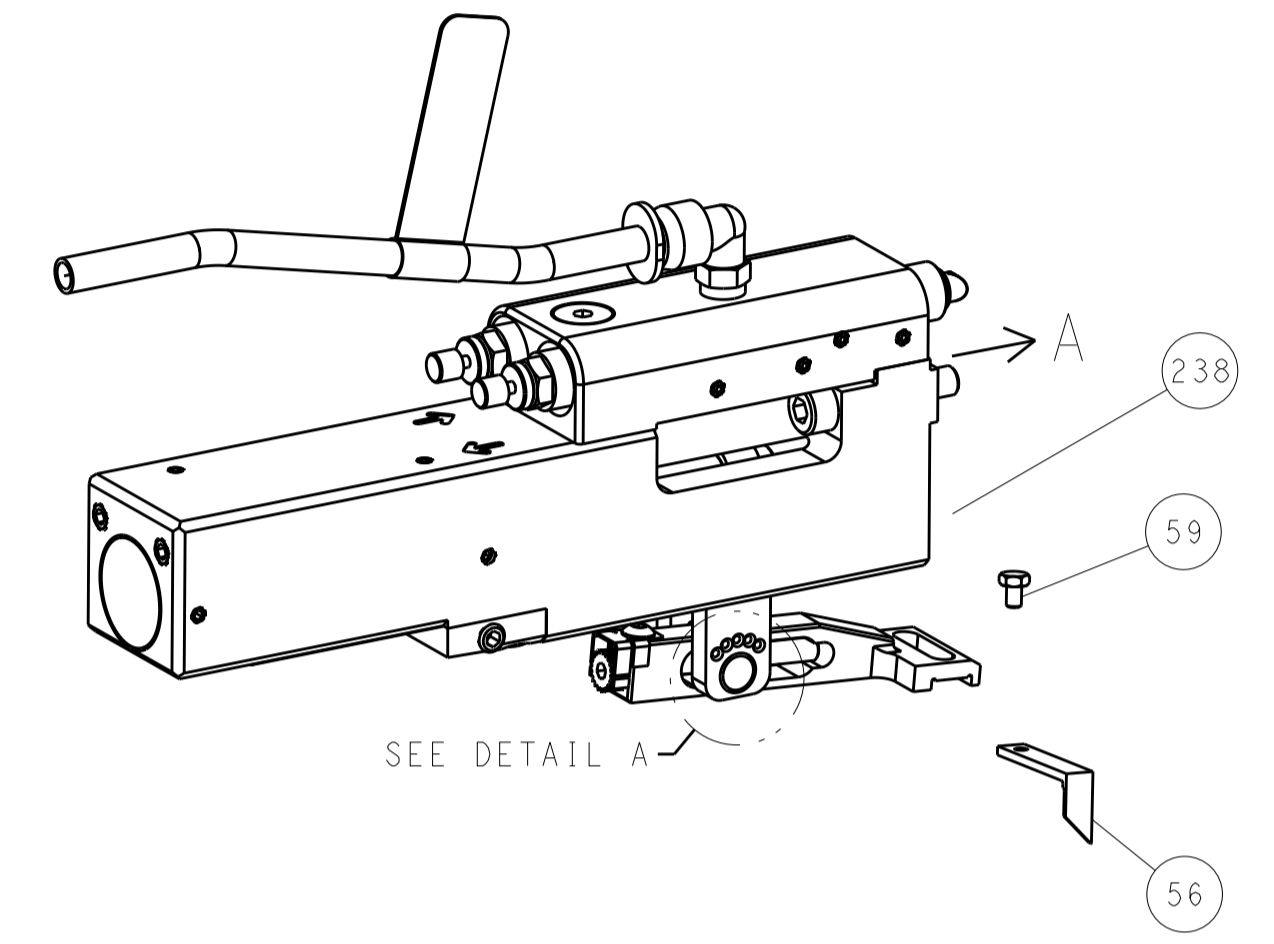

FEED SPRING SETTING POSITION (SHOWN FROM REAR SIDE)

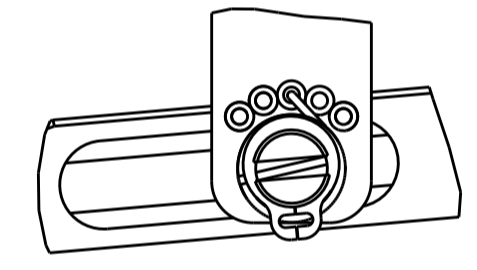

DETAIL A

CAM POSITION

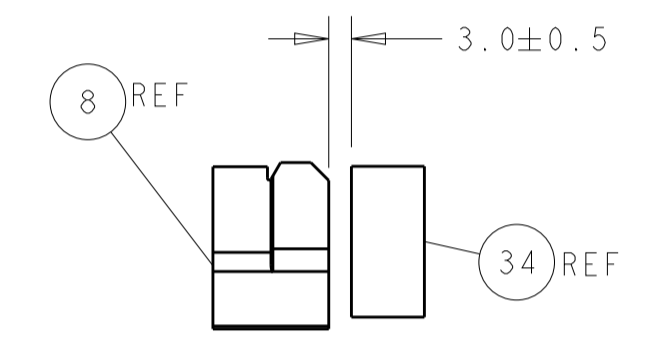
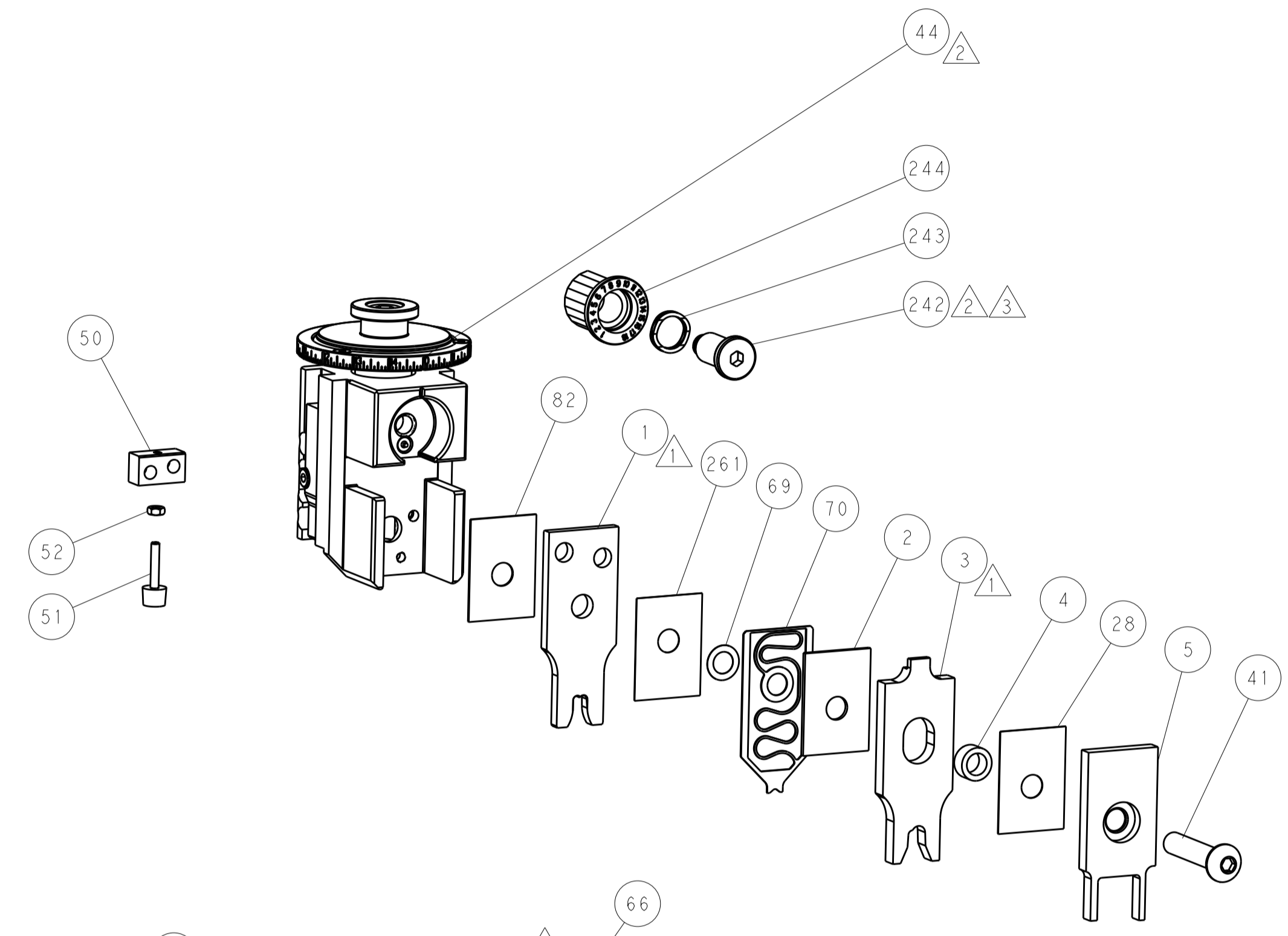
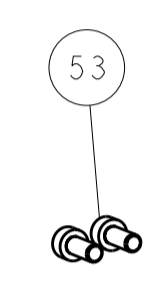
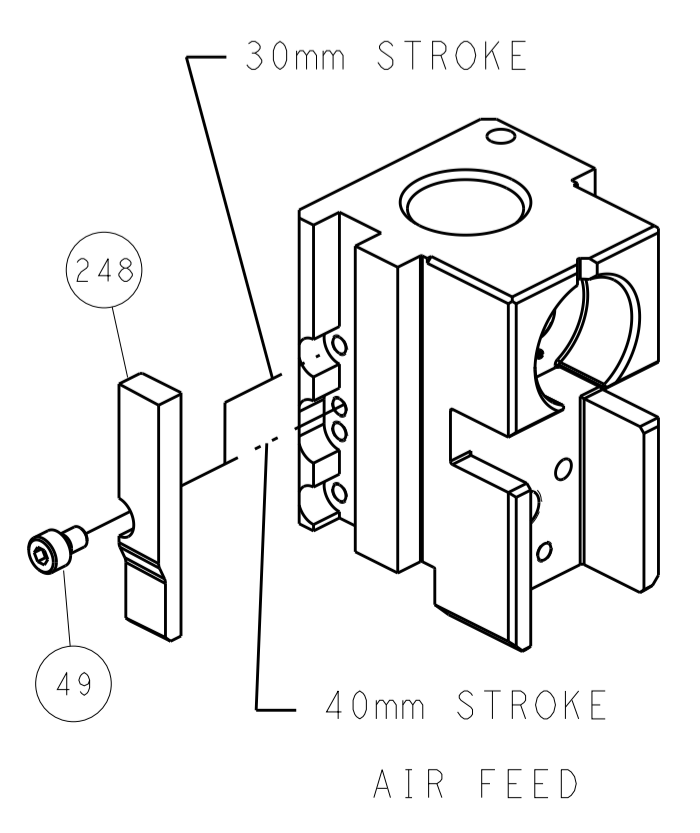

TERMINAL SUPPORT LOCATION

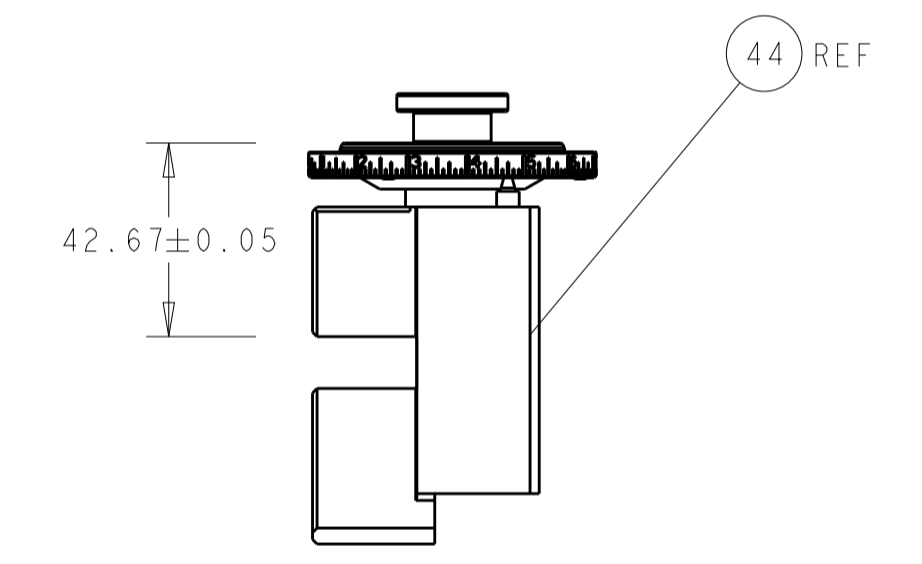

RAM SET-UP

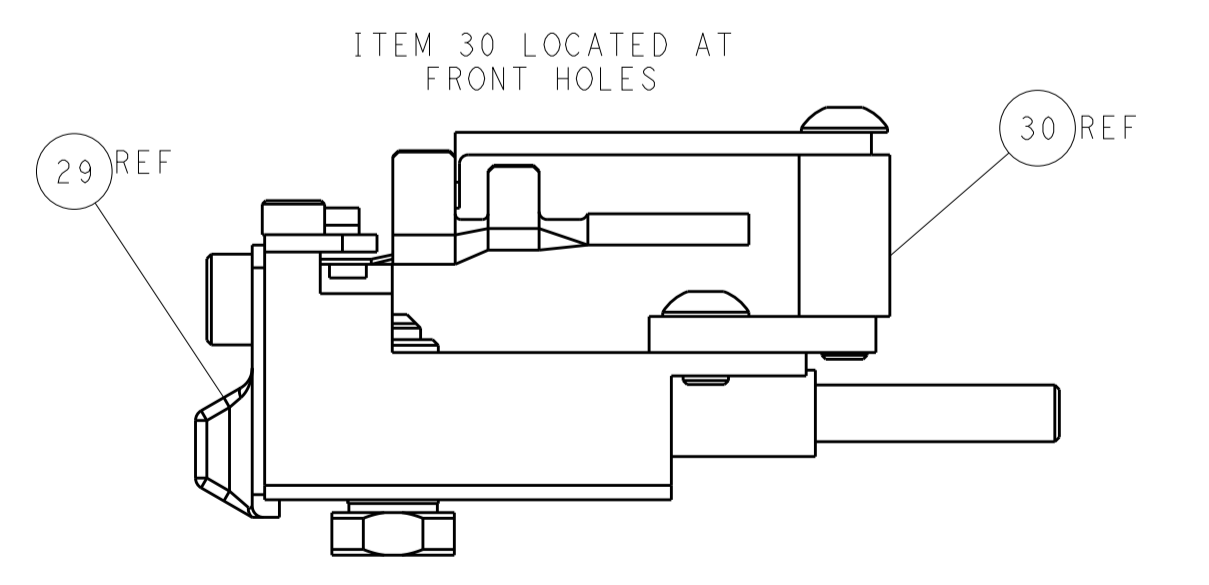

FEED TRACK POSITION GUIDE BY INSULATION BARREL

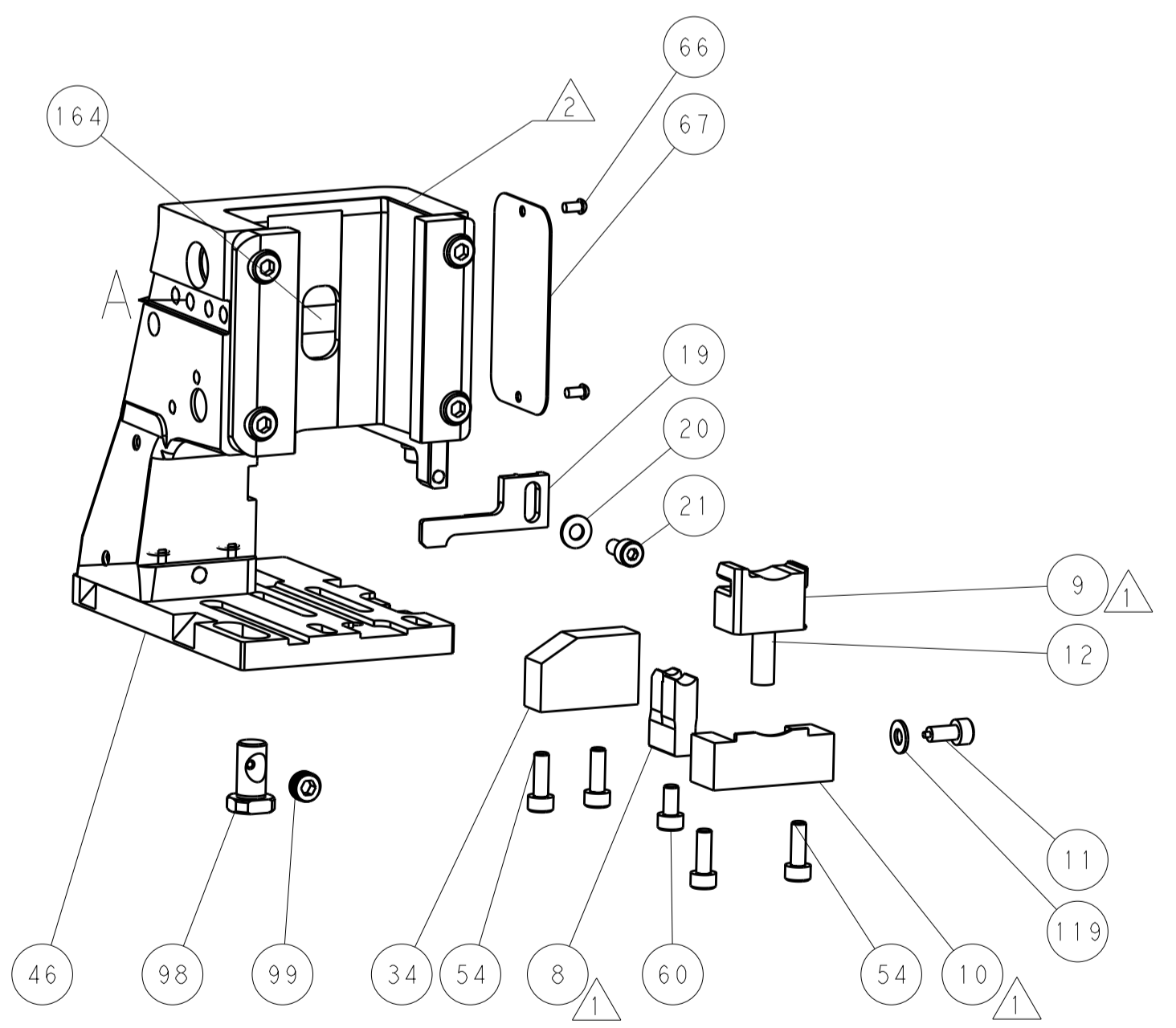
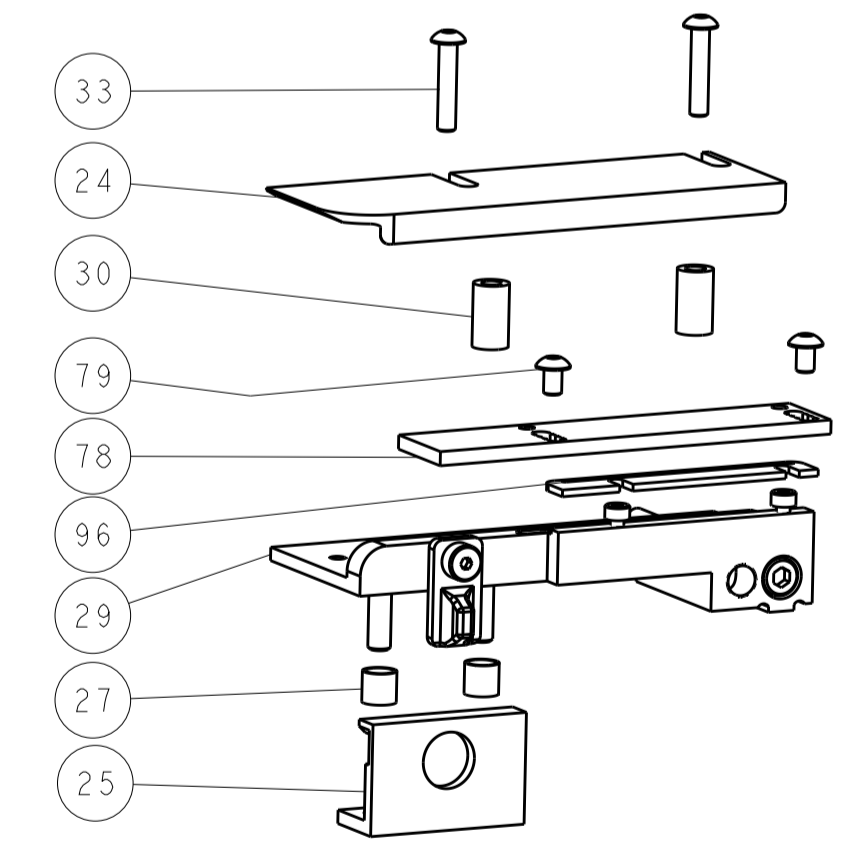

ATLANTIC VERSION
 Shown on sheets 1 of 4 & 2 of 4
 (Pacific version shown on sheets 3 of 4 & 4 of 4)

DIMENSIONS: mm 		TOLERANCES UNLESS OTHERWISE SPECIFIED: 0 PLC ± 1 PLC ± 2 PLC ± 3 PLC ± 4 PLC ± ANGLES ±		DWN R. HUANG 29NOV2013 CHK L. ZHANG 29NOV2013 APVD H. GUO 29NOV2013 NAME Ocean Side Feed Applicator SIZE CAGE CODE DRAWING NO RESTRICTED TO A1 00779 C=2266164 Customer Accessible Production Drawing SCALE 1:2 SHEET 2 OF 4 REV D	
MATERIAL:		FINISH:		WEIGHT:	

PART NUMBER	REVISION	DESCRIPTION	FEED TYPE
2-2266164-2	D	FINE CRIMP HEIGHT ADJUST	PNEUMATIC
7-2266164-7	C	CRIMP TOOLING KIT	-

PACIFIC VERSION TERMINATOR INTERFACE ADAPTER



APPLICATOR DATA		
CRIMP	SIZE	TYPE
WIRE	5.50 mm [.217]	F
INSUL	6.90 mm [.272]	OV
APPLICATOR INSTRUCTIONS 408-35042		

TERMINAL DATA: TE TERMINAL		TE CRIMP SPECIFICATION	
TERMINAL NAME: CLIP 8 mm NG1 CAPACITE 7 A 10 mm ²			
WIRE STRIP LENGTH		INSULATION DIAMETER RANGE	
7.00-7.00 mm [.276-.276 IN]		Ø4.90-6.00 mm [.193-.236 IN]	
TERMINAL APPLICATION SPECIFICATION		Proner Comatel 2398 C 002 -	
TERMINALS APPLIED			
TE TERMINAL	TE TERMINAL	TE SEAL	TE SEAL
1544228-1			

TERMINAL DATA: TE TERMINAL		TE CRIMP SPECIFICATION	
TERMINAL NAME: CLIP 8 mm NG1 CAPACITE 7 A 10 mm ²			
WIRE STRIP LENGTH		INSULATION DIAMETER RANGE	
7.00-7.00 mm [.276-.276 IN]		Ø4.90-6.00 mm [.193-.236 IN]	
TERMINAL APPLICATION SPECIFICATION			
TERMINALS APPLIED			
TE TERMINAL	TE TERMINAL	TE SEAL	TE SEAL
1544228-1			

WIRE SIZE	CRIMP HEIGHT WT_CRIMP_UNIT	CRIMP HEIGHT REFERENCE SETTING
10.18mm ²	3.52+/-0.05 [.139+/- .002]	5.5
10.05mm ²	3.52+/-0.05 [.139+/- .002]	5.5
7.42mm ²	3.20+/-0.05 [.126+/- .002]	8.5
7.26mm ²	3.18+/-0.05 [.125+/- .002]	8.7

WIRE SIZE	CRIMP HEIGHT mm [INCH]	CRIMP HEIGHT REFERENCE SETTING
10.00mm ²	3.52+/-0.05 [.139+/- .002]	5.5

LOC	DIST	REVISIONS			
		REV	DATE	DWN	APVD
A	66	-	SEE SHEET 1		

QTY	DESCRIPTION	DATE	DWN	APVD
- 1	455888-1 SPACER, CRIMPER			261
- 1	2119082-7 CAM, SNAIL, INSULATION ADJUSTMENT			244
- 1	2079764-1 WASHER, WAVE SPRING, CREST-TO-CREST			243
- 1	2119083-1 RETAINER, INSULATION DIAL			242
- 1	2844940-2 AIR FEED MODULE			238
- REF	994970-2 COUNTER, MAGNETIC			164
- 1	2119641-2 FEED CAM, AIR FEED			151
- 1	2168083-8 SCR, SKT HD CAP, RoHS, M4 X 16			144
- 4	2168083-9 SCR, SKT HD CAP, RoHS, M4 X 20			143
- 1	1-1803583-8 APPLICATOR BASIC ASSEMBLY, SF			141
- 1	1803516-2 RAM ASSEMBLY, SF PACIFIC			140
- 1	1-18028-2 WASHER, FLAT, REG M4			119
- 1	2844908-1 SCREW, LOCKING			99
- 1	2844907-1 POST, LOCKING			98
- 1	1-690438-0 FRONT STRIP GUIDE			96
- 1	455888-5 SPACER, CRIMPER			82
- 2	1-2079383-8 SCR, BHSC, RoHS (M4 X 6)			79
- 1	1803096-1 EXTENSION PLATE			78
- 1	1803607-3 DOCUMENTATION PACKAGE			71
- 1	2119791-5 DEPRESSOR, WIRE			70
- 1	2119943-1 WASHER, SPACER			69
- 1	2119740-1 TAG, IDENTIFICATION			67
- 2	2168078-1 SCREW, DRIVE, RH, RoHS, 2 x .188			66
- 1	5-18022-5 SCR, HEX HD CAP, M4 X 6.0			59
- 1	1-1338683-1 FEED PAWL			56
- 2	1-2168083-0 SCR, SKT HD CAP, RoHS, M4 X 10			53
- 1	5018030-1 NUT, HEX, REG, RoHS, M3			52
- 1	811242-5 BUMPER, HOLD DOWN			51
- 1	690753-2 SPACER, TONKER			50
- 1	18023-9 SCR, SKT HD CAP M4 X 6.0			49
- 1	1803602-2 SCR, BHSC, RoHS (M8 X 40)			41
- 1	1752356-2 SUPPORT, TERMINAL			34
- 2	2079383-5 SCR, BHSC, RoHS (M4 X 20)			33
- 2	2-2844962-6 SPACER, CYLINDRICAL, STRIP GUIDE			30
- 1	2844992-5 ASSEMBLY, STRIP GUIDE			29
- 1	455888-3 SPACER, CRIMPER			28
- 2	22281-8 SPRING, COMPRESSION			27
- 1	240792-1 DRAG, TERMINAL			25
- 1	1320928-6 STRIP GUIDE			24
- 1	2168083-2 SCR, SKT HD CAP, RoHS, M4 X 8.0			21
- 1	1-18028-2 WASHER, FLAT, REG M4			20
- 1	2119533-1 STRIPPER, SIDE FEED			19
- 1	3-22280-3 SPRING, COMPRESSION			12
- 1	1-356885-3 STOP, SHEAR			11
- 1	1-2119805-2 SHEAR HOLDER, FRONT			10
- 1	1-318059-0 FLOATING SHEAR, FRONT			9
- 1	7-1633930-7 ANVIL, COMBINATION			8
-	-			7
-	-			6
- 1	1803080-1 DEPRESSOR, SHEAR			5
- 1	4-238011-4 BLOCK, CRIMPER SPACER			4
- 1	1803462-1 CRIMPER, INSULATION OVERLAP PREMIUM			3
- 1	1-455888-2 SPACER, CRIMPER			2
- 1	8-1490019-3 CRIMPER, WIRE PREMIUM			1

- 1 RECOMMENDED SPARE PARTS
- 2 REFER TO SUPPLIED INSTRUCTION SHEET FOR CLEANING, LUBRICATION AND STORAGE OF APPLICATOR.
- 3 APPLY PART NUMBER 2-23419-6 LOCTITE TO THREADS OF ITEM 242.
- 4 CRIMP HEIGHT REFERENCE SETTING WAS THE SETTING USED WHEN THE APPLICATOR WAS QUALIFIED AT THE FACTORY. ADJUSTMENT MAY BE NECESSARY WHEN RUNNING APPLICATOR IN THE FIELD.
- 5 UNLESS SPECIFIED OTHERWISE TORQUE VALUES SHALL BE USED PER DOCUMENT, 101-35000.
- 6 WIRE SIZE OVER 10mm² IS NOT RECOMMENDED, PLS CHECK PRESS COMPATIBILITY OF TERMINATOR.
- 7 TERMINAL PITCH NOT COMPATIBLE WITH MECHANICAL FEED.
- 8 THIS CRIMP PARAMETER IS PROVIDED TO MEET A CUSTOM AND UNIQUE CUSTOMER REQUIREMENT. IT HAS BEEN EVALUATED AND IS CONDITIONALLY SPECIFIED BY TE CONNECTIVITY. THIS CUSTOMIZED CRIMP PARAMETER IS NOT LISTED AS AN APPROVED APPLICATION WITHIN A TE CONNECTIVITY APPLICATION SPECIFICATION. **TE CONNECTIVITY EXPRESSLY DISCLAIMS ANY AND ALL WARRANTIES THAT THE PRODUCT WILL PERFORM SIMILARLY TO VALIDATED AND APPROVED APPLICATIONS, AS STATED WITHIN TE CONNECTIVITY APPLICATION SPECIFICATIONS, INCLUDING BUT NOT LIMITED TO IMPLIED WARRANTIES OF MERCHANTABILITY OR FITNESS FOR PARTICULAR PURPOSE.** AS SUCH, IT IS HIGHLY RECOMMENDED THAT THE CUSTOMER PERFORM FURTHER DETAILED EVALUATION TO ASSESS PRODUCT PERFORMANCE IN THE SPECIFIC APPLICATION.

***WARNING**
ON INSTALLATION, SET WIRE DISC TO CRIMP HEIGHT REFERENCE SETTING FOR LARGEST WIRE SIZE. CRIMP HEIGHT REFERENCE SETTINGS GREATER THAN THE VALUE SHOWN MAY CAUSE DAMAGE TO THE CRIMP TOOLING, REFER TO THE INSTRUCTION SHEET FOR PROPER SETUP AND ADJUSTMENTS.

PACIFIC VERSION
Shown on sheets 3 of 4 & 4 of 4
(Atlantic version shown on sheets 1 of 4 & 2 of 4)

DIMENSIONS: mm		TOLERANCES UNLESS OTHERWISE SPECIFIED:		DWN CH HUANG 29NOV2013		 TE Connectivity Harrisburg, PA 17105-3608
mm		0 PLC ±		CHK L ZHANG 29NOV2013		
mm		1 PLC ±		APVD JJ GUO 29NOV2013		
mm		5 PLC ±		PRODUCT SPEC		
mm		4 PLC ±		APPLICATION SPEC		
MATERIAL		FINISH		WEIGHT		SIZE CAGE CODE DRAWING NO A1 00779 ©=2266164
Customer Accessible Production Drawing				SCALE 1:2		SHEET 3 OF 4 REV D

LOC		DIST		REVISIONS			
A	66	P	LTH	DESCRIPTION	DATE	DWN	APVD
		-	-	SEE SHEET 1	-	-	-

FEED TYPE

PNEUMATIC

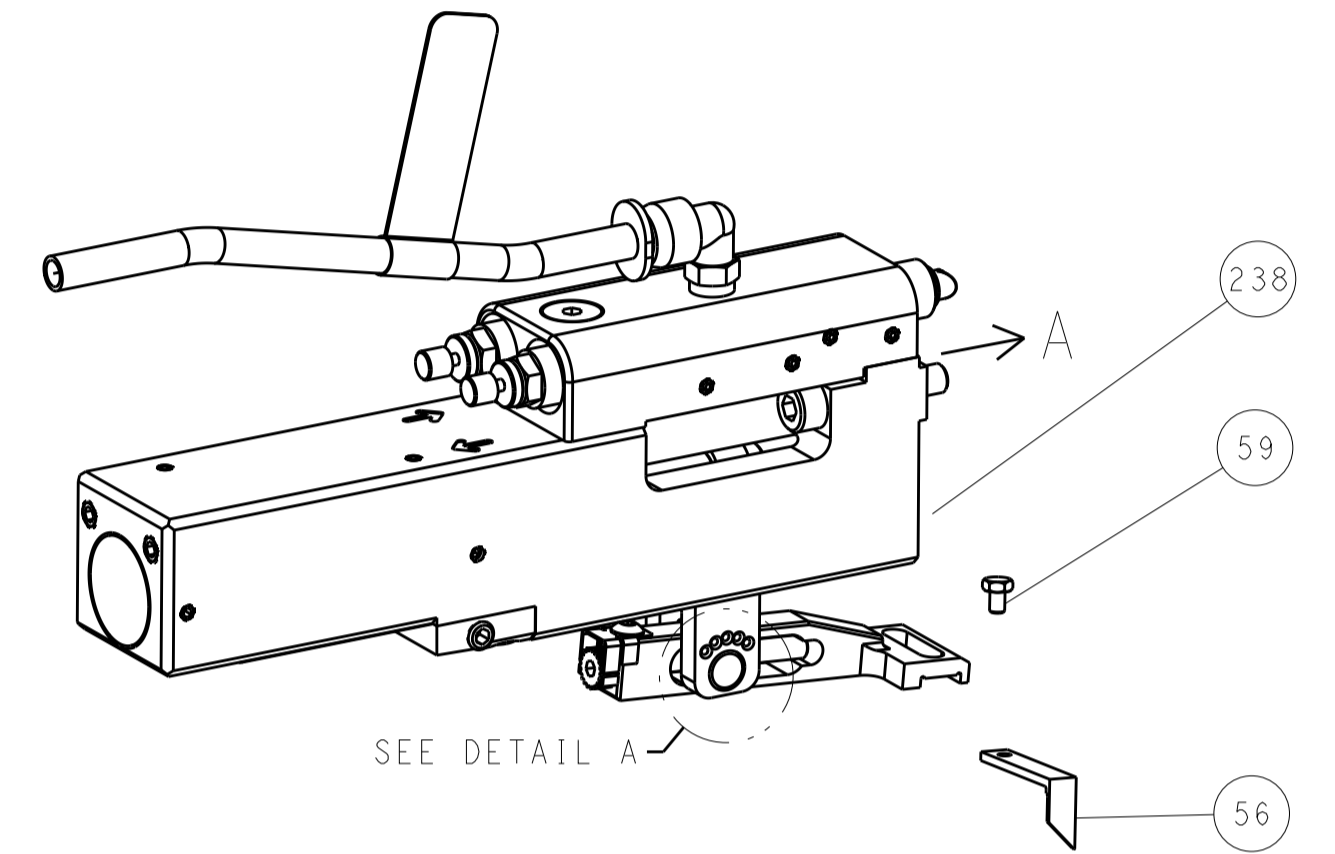

SEE DETAIL A

FEED SPRING SETTING POSITION (SHOWN FROM REAR SIDE)

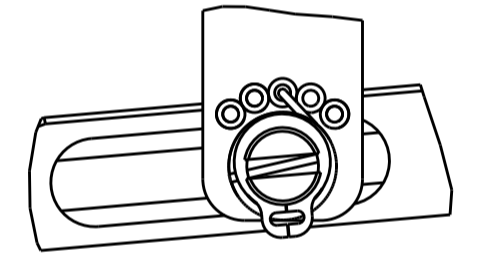

DETAIL A

CAM POSITION

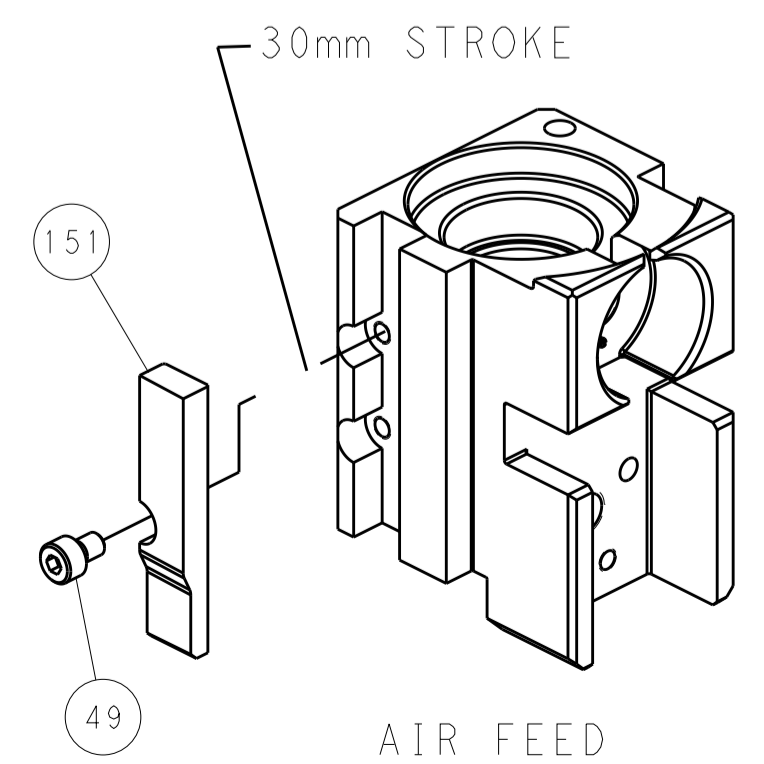

AIR FEED

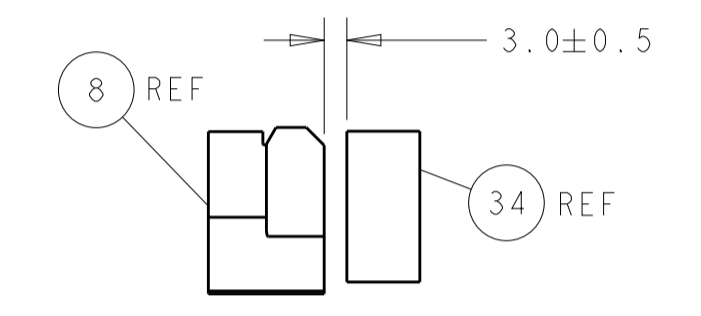
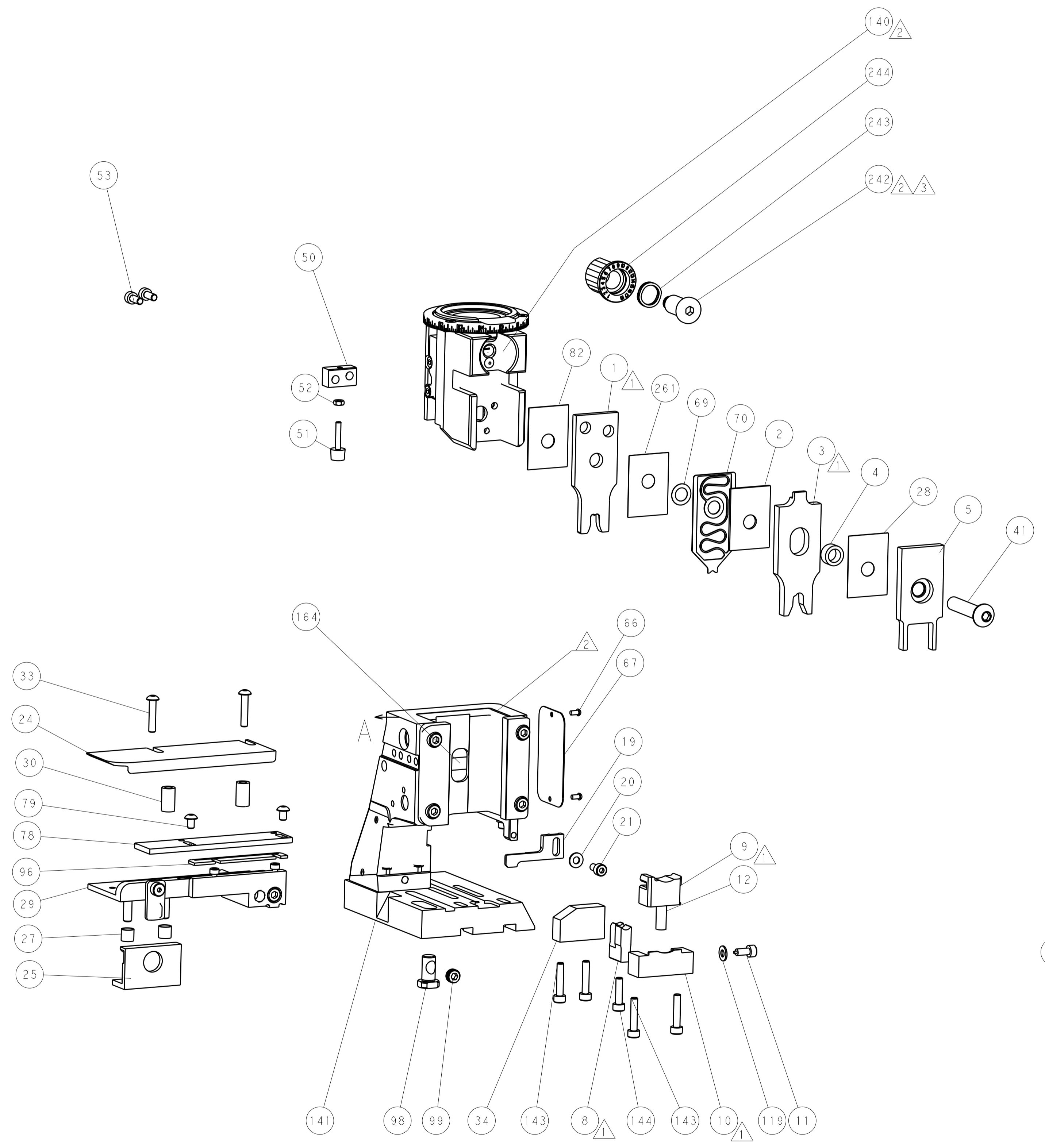

TERMINAL SUPPORT LOCATION

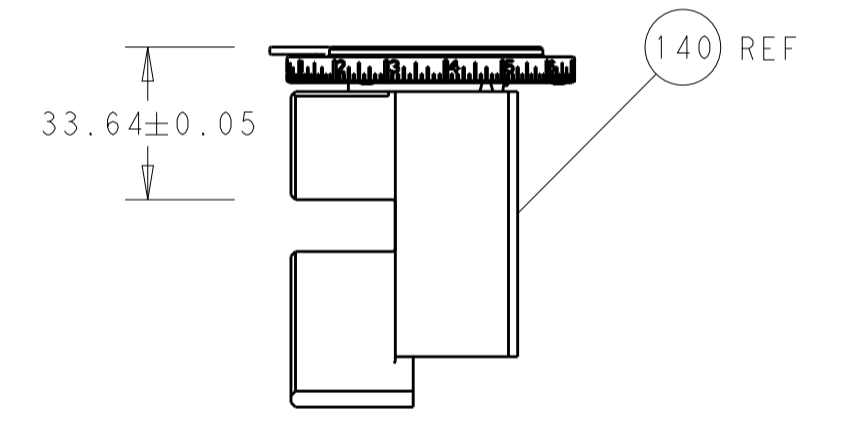

RAM SET-UP

ITEM 30 LOCATED AT FRONT HOLES

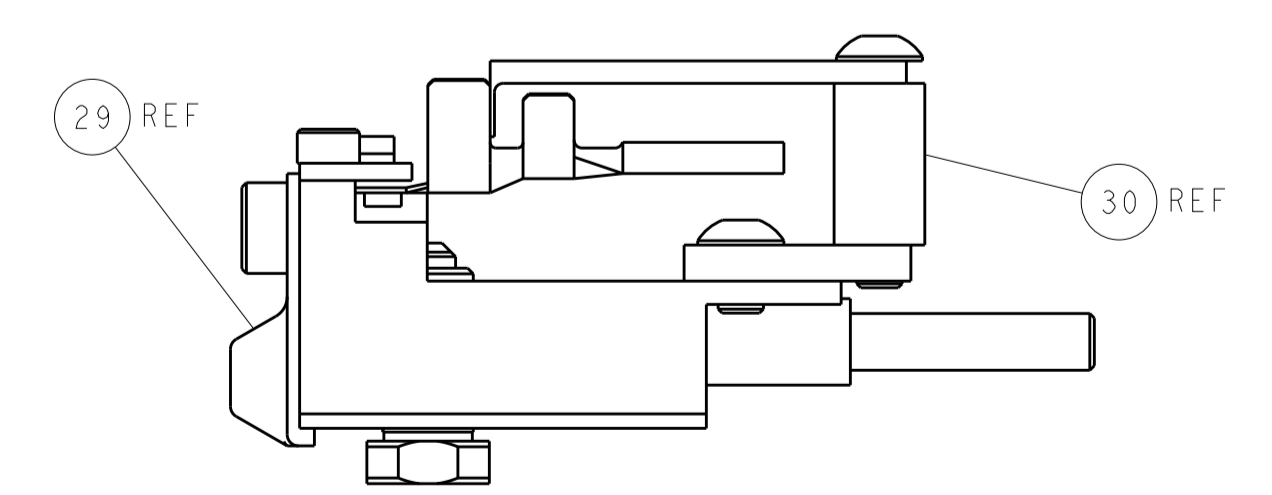

FEED TRACK POSITION GUIDE BY INSULATION BARREL

PACIFIC VERSION
 Shown on sheets 3 of 4 & 4 of 4
 (Atlantic version shown on sheets 1 of 4 & 2 of 4)

DIMENSIONS:		TOLERANCES UNLESS OTHERWISE SPECIFIED:		DWN H. HUANG 29NOV2013		CHK L. ZHANG 29NOV2013		APVD H. GUO 29NOV2013		NAME Ocean Side Feed Applicator	
mm	0 PLC	±		PRODUCT SPEC		SIZE	CAGE CODE	DRAWING NO	RESTRICTED TO		
	1 PLC	±		APPLICATION SPEC		WT	00779	2266164			
	2 PLC	±				SCALE	1:2	SHEET 4	OF 4	REV	D
	3 PLC	±				Customer Accessible Production Drawing					
	4 PLC	±									
	ANGLES	±									