

REF. -50 OPT. SCREW
(WHERE APPLICABLE)

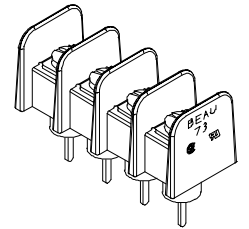

AUX. VIEW
SCALE 1:1
(4 CIRCUIT SHOWN)

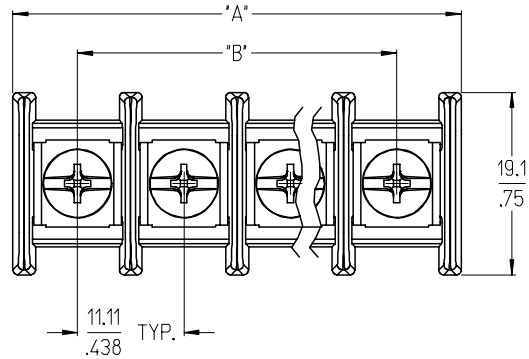
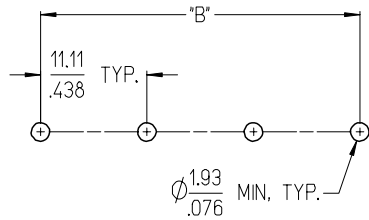

RECOMMENDED PCB LAYOUT

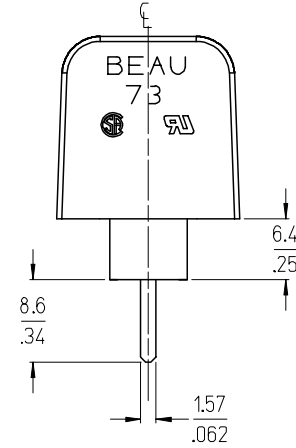
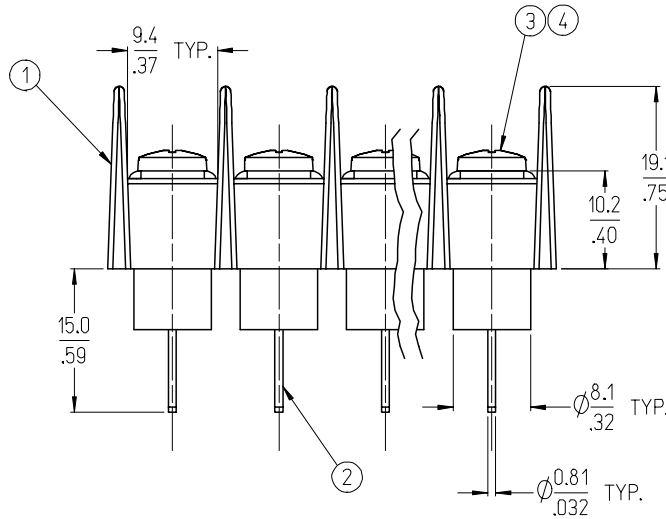

NOTES:

1. MATERIAL: SEE TABLE
2. FINISHES: SEE TABLE
3. 'XX' REFERS TO QUANTITY OF CIRCUITS.
4. ASSEMBLY IS ROHS COMPLIANT.

ITEM	QTY.	DESCRIPTION	MATERIAL	FINISH
5	XX	SCREW, #6-32X.250 PAN PH-SL W/SQ WASHER (-50 OPT)	STEEL	ZN, CLEAR CHROMATE
4	XX	SCREW, #6-32 X.250 BINDING HEAD PHIL-SLOT (-49 OPT)	BRASS	NICKEL PLATE
3	XX	SCREW, #6-32 X.250 BINDING HEAD PHIL-SLOT (STD. SCREW)	STEEL	ZN, CLEAR CHROMATE
2	XX	TERMINAL, STYLE 3, WW	BRASS	TIN PLATE
1	1	INSULATOR, NO MTG, INSUL. BASE	PBT, UL 94V-0	BLACK

INITIAL RELEASE
EC NO: ETC2008-0034
DRAWN: CLYORK 2007/08/12
CHKD: JMACNEIL 2007/09/12
APPR: JMACNEIL 2007/09/13

QUALITY SYMBOLS

 DESCRIPTION
 REV

GENERAL TOLERANCES (UNLESS SPECIFIED)	
	MM/INCH
4 PLACES	± --- ± ---
3 PLACES	± --- ± .005
2 PLACES	± 0.13 ± .01
1 PLACE	± 0.3 ± ---
ANGULAR ± 2 °	

DIMENSION STYLE	
MM/IN	
DRAWN BY	DATE
C. YORK	2007/08/15
CHECKED BY	DATE
J. MACNEIL	2007/08/15
APPROVED BY	DATE
J. MACNEIL	2007/08/15
MATERIAL NO.	DATE
SEE SHT. 2	

SCALE	DESIGN UNITS	THIRD ANGLE PROJECTION
2:1	INCH	
TITLE		
11.11/.438 SR BTS ASY, INSUL PC, NO MTG		
MATERIAL NO.		
SEE SHT. 2		
DOCUMENT NO.		
SD-38730-004		
SHEET NO.		
1 OF 2		

THIS DRAWING CONTAINS INFORMATION THAT IS PROPRIETARY TO MOLEX INCORPORATED AND SHOULD NOT BE USED WITHOUT WRITTEN PERMISSION

# OF CIRCUITS "XX"	DIM. "A"		DIM. "B"		ASSEMBLY MATERIAL NO. (-C OPT)	ASSEMBLY MATERIAL NO. (-C-49 OPT)	ASSEMBLY MATERIAL NO. (-C-50 OPT)
	mm	in	mm	in			
02	24.5	.97	11.11	.438	387304802	387305102	387305402
03	35.7	1.40	22.23	.875	387304803	387305103	387305403
04	46.8	1.84	33.34	1.313	387304804	387305104	387305404
05	57.9	2.28	44.45	1.750	387304805	387305105	387305405
06	69.0	2.72	55.56	2.188	387304806	387305106	387305406
07	80.1	3.15	66.68	2.625	387304807	387305107	387305407
08	91.2	3.59	77.79	3.063	387304808	387305108	387305408
09	102.3	4.03	88.90	3.500	387304809	387305109	387305409
10	113.4	4.47	100.01	3.938	387304810	387305110	387305410
11	124.6	4.90	111.13	4.375	387304811	387305111	387305411
12	135.7	5.34	122.24	4.813	387304812	387305112	387305412
13	146.8	5.78	133.35	5.250	387304813	387305113	387305413
14	157.9	6.22	144.46	5.688	387304814	387305114	387305414
15	169.0	6.65	155.58	6.125	387304815	387305115	387305415
16	180.1	7.09	166.69	6.563	387304816	387305116	387305416
17	191.2	7.53	177.80	7.000	387304817	387305117	387305417
18	202.3	7.97	188.91	7.438	387304818	387305118	387305418
19	213.5	8.40	200.03	7.875	387304819	387305119	387305419
20	224.6	8.84	211.14	8.313	387304820	387305120	387305420
21	235.7	9.28	222.25	8.750	387304821	387305121	387305421
22	246.8	9.72	233.36	9.188	387304822	387305122	387305422
23	257.9	10.15	244.48	9.625	387304823	387305123	387305423
24	269.0	10.59	255.59	10.063	387304824	387305124	387305424
25	280.1	11.03	266.70	10.500	387304825	387305125	387305425
26	291.2	11.47	277.81	10.938	387304826	387305126	387305426
27	302.4	11.90	288.93	11.375	387304827	387305127	387305427
28	313.5	12.34	300.04	11.813	387304828	387305128	387305428
29	324.6	12.78	311.15	12.250	387304829	387305129	387305429
30	335.7	13.22	322.26	12.688	387304830	387305130	387305430

SEE SHEET 1 EC NO: ETC2008-0034 DRWN: C. YORK 2007/08/12 CHKD: J. MACNEIL 2007/09/12 APPR: J. MACNEIL 2007/09/13	DESCRIPTION A	QUALITY SYMBOLS ▽=0 ▽=0	GENERAL TOLERANCES (UNLESS SPECIFIED) mm INCH 4 PLACES ± --- ± --- 3 PLACES ± --- ± .005 2 PLACES ± 0.13 ± .01 1 PLACE ± 0.3 ± --- ANGULAR ± 2 °	DIMENSION STYLE MM/IN DRAWN BY DATE C. YORK 2007/08/15 CHECKED BY DATE J. MACNEIL 2007/08/15 APPROVED BY DATE J. MACNEIL 2007/08/15	SCALE 2:1 DESIGN UNITS INCH THIRD ANGLE PROJECTION	TITLE 11.11/.438 SR BTS ASY, INSUL PC, NO MTG
		DRAFT WHERE APPLICABLE MUST REMAIN WITHIN DIMENSIONS	MATERIAL NO. SEE CHART	MOLEX INCORPORATED DOCUMENT NO. SD-38730-004	SHEET NO. 2 OF 2	
		SIZE B	THIS DRAWING CONTAINS INFORMATION THAT IS PROPRIETARY TO MOLEX INCORPORATED AND SHOULD NOT BE USED WITHOUT WRITTEN PERMISSION			