

ADM6999U/UX

9 port 10/100 Mb/s Single Chip Ethernet Switch
Controller

Communications



Never stop thinking.

Edition 2005-11-25

**Published by Infineon Technologies AG,
St.-Martin-Strasse 53,
81669 München, Germany**

**© Infineon Technologies AG 2005.
All Rights Reserved.**

Attention please!

The information herein is given to describe certain components and shall not be considered as a guarantee of characteristics.

Terms of delivery and rights to technical change reserved.

We hereby disclaim any and all warranties, including but not limited to warranties of non-infringement, regarding circuits, descriptions and charts stated herein.

Information

For further information on technology, delivery terms and conditions and prices please contact your nearest Infineon Technologies Office (www.infineon.com).

Warnings

Due to technical requirements components may contain dangerous substances. For information on the types in question please contact your nearest Infineon Technologies Office.

Infineon Technologies Components may only be used in life-support devices or systems with the express written approval of Infineon Technologies, if a failure of such components can reasonably be expected to cause the failure of that life-support device or system, or to affect the safety or effectiveness of that device or system. Life support devices or systems are intended to be implanted in the human body, or to support and/or maintain and sustain and/or protect human life. If they fail, it is reasonable to assume that the health of the user or other persons may be endangered.

9 port 10/100 Mb/s Single Chip Ethernet Switch Controller

Revision History: 2005-11-25, Rev. 1.42

Previous Version:

Page/Date	Subjects (major changes since last revision)
2002-08	Rev. 0.1: First Infineon ADMtek Co Ltd version
2002-09	Rev. 1.0: Remove Preliminary word
2002-12	Rev. 1.1: Modify error word. Add Expansion Port Timing.
2003-04	Rev. 1.2: Modify expansion Port Setup/Hold time. Remove LEDEN pin to NC.
2003-05	Rev. 1.3: A2 version RTX value change to 1K 1%
2004-04	Rev. 1.4: Updated logo to Infineon ADMtek
2005-09	Rev. 1.41: Changed to the new Infineon format
2005-11-25	Rev. 1.41 changed to Rev. 1.42 Minor change. Included Green package information

Trademarks

ABM[®], ACE[®], AOP[®], ARCOFI[®], ASM[®], ASP[®], DigiTape[®], DuSLIC[®], EPIC[®], ELIC[®], FALC[®], GEMINAX[®], IDEC[®], INCA[®], IOM[®], IPAT[®]-2, ISAC[®], ITAC[®], IWE[®], IWORX[®], MUSAC[®], MuSLIC[®], OCTAT[®], OptiPort[®], POTSWIRE[®], QUAT[®], QuadFALC[®], SCOUT[®], SICAT[®], SICOFI[®], SIDEC[®], SLICOFI[®], SMINT[®], SOCRATES[®], VINETIC[®], 10BaseV[®], 10BaseVX[®] are registered trademarks of Infineon Technologies AG. 10BaseS[™], EasyPort[™], VDSLite[™] are trademarks of Infineon Technologies AG. Microsoft[®] is a registered trademark of Microsoft Corporation, Linux[®] of Linus Torvalds, Visio[®] of Visio Corporation, and FrameMaker[®] of Adobe Systems Incorporated.

Table of Contents

	Table of Contents	4
	List of Figures	6
	List of Tables	7
1	Introduction	8
1.1	General Description	8
1.2	Features	8
1.3	Applications	9
2	Input and Output Signals	10
2.1	Pin Diagram	10
2.2	Pin Type and Buffer Type Abbreviations	11
2.3	Pin Description	12
3	Descriptions	17
3.1	Functional Description	17
3.2	10/100M PHY Block Description	17
3.2.1	100Base-X Module	17
3.2.2	100Base-X Receiver	17
3.2.2.1	A/D Converter	18
3.2.2.2	Adaptive Equalizer and Timing Recovery Module	18
3.2.2.3	NRZI/NRZ and Serial/Parallel Decoder	18
3.2.2.4	Data De-scrambling	19
3.2.2.5	Symbol Alignment	19
3.2.2.6	Symbol Decoding	19
3.2.2.7	Valid Data Signal	19
3.2.2.8	Receive Errors	19
3.2.2.9	100Base-X Link Monitor	19
3.2.2.10	Carrier Sense	20
3.2.2.11	Bad SSD Detection	20
3.2.2.12	Far-End Fault	20
3.2.3	100Base-TX Transceiver	20
3.2.3.1	Transmit Drivers	20
3.2.3.2	Twisted-Pair Receiver	20
3.2.4	10Base-T Module	21
3.2.4.1	Operation Modes	21
3.2.4.2	Manchester Encoder/Decoder	21
3.2.4.3	Transmit Driver and Receiver	21
3.2.4.4	Smart Squelch	21
3.2.5	Carrier Sense	22
3.2.6	Jabber Function	22
3.2.7	Link Test Function	22
3.2.8	Automatic Link Polarity Detection	22
3.2.9	Clock Synthesizer	22
3.2.10	Auto Negotiation	22
3.3	Memory Block Description	23
3.4	Switch Functional Description	23
3.4.1	Basic Operation	23
3.4.1.1	Address Learning	23
3.4.1.2	Address Recognition and Packet Forwarding	23

Table of Contents

3.4.1.3	Address Aging	24
3.4.1.4	Back off Algorithm	24
3.4.1.5	Inter-Packet Gap (IPG)	24
3.4.1.6	Illegal Frames	24
3.4.1.7	Half Duplex Flow Control	24
3.4.1.8	Full Duplex Flow Control	24
3.4.1.9	Broadcast Storm Filter	25
3.4.2	Auto TP MDIX Function	25
3.4.3	Port Locking	25
3.4.4	VLAN Setting & Tag/Untag & Port-base VLAN	25
3.4.5	Priority Setting	26
3.4.6	LED Display	26
3.4.6.1	Serial LED Interface	27
3.4.6.2	Scan LED Interface	27
3.5	EEPROM Content	29
3.5.1	EEPROM Registers Overview	31
3.5.1.1	EEPROM Registers Description	33
3.6	EEPROM Access Description	59
4	TX/FX Interface	61
4.1	TP Interface	61
4.2	FX Interface	61
5	DC Characteristics	63
6	Serial Management	64
6.1	Serial Registers Map	64
6.1.1	Serial Registers Description	66
6.2	Serial Interface Timing	77
7	AC Characteristics	79
7.1	Power On Reset	79
7.2	EEPROM Data Timing	79
7.3	Expansion Bus Receive Signals Timing	80
7.4	Expansion Bus Transmit Signals Timing	80
7.5	SMI Timing	81
8	Package	82
	References	83
	Terminology	84

List of Figures

Figure 1	ADM6999U/UX's Application	9
Figure 2	ADM6999U/UX 128 Pin Diagram	10
Figure 3	100Base-X Module	18
Figure 4	Serial LED Interface	27
Figure 5	Scan LED Interface	28
Figure 6	Router old architecture	44
Figure 7	New architecture by using ADM6999U/UX serial chip VLAN function	45
Figure 8	ADM6999U/UX serial chips EEPROM pins operation	59
Figure 9	EEPROM Writing Command	60
Figure 10	TP Interface	61
Figure 11	FX Interface	62
Figure 12	Serial Interface Timing X	77
Figure 13	Serial Interface Timing Y	78
Figure 14	Power On Reset	79
Figure 15	EEPROM Data Timing	79
Figure 16	Expansion Bus Receive Signals Timing	80
Figure 17	Expansion Bus Transmit Signals Timing	81
Figure 18	SMI Timing	81
Figure 19	ADM6999U/UX 128 Pin PQFP Outside Dimension	82

List of Tables

Table 1	Abbreviations for Pin Type	11
Table 2	Abbreviations for Buffer Type	11
Table 3	ADM6999U/UX 128 Pin Descriptions	12
Table 4	Port Rising/Falling Threshold	25
Table 5	LED Display	27
Table 6	LED Corresponding Interface	28
Table 7	EEPROM Register Map	29
Table 8	Registers Address Space	Registers Address Space 31
Table 9	Registers Overview	31
Table 10	Register Access Types	32
Table 11	Registers Clock Domains	Registers Clock Domains 33
Table 12	PCR_x Registers	Table 35
Table 13	Per Port Rising Threshold	42
Table 14	Per Port Falling Threshold	42
Table 15	Drop Scheme for each Queue	42
Table 16	ADM6996 Port Mapping with ADM6999U/UX	44
Table 17	VLAN_MTR_x Registers	Table 49
Table 18	RC & EEPROM Content Relationship	59
Table 19	Absolute Maximum Ratings	63
Table 20	Recommended Operating Conditions	63
Table 21	DC Electrical Characteristics for 3.3 V Operation	63
Table 22	Registers Address Space	Registers Address Space 64
Table 23	Registers Overview	64
Table 24	Register Access Types	65
Table 25	Registers Clock Domains	Registers Clock Domains 66
Table 26	Port Registers RPC_x	72
Table 27	Power On Reset	79
Table 28	EEPROM Data Timing	79
Table 29	Expansion Bus Receive Signals Timing	80
Table 30	Expansion Bus Transmit Signals Timing	81
Table 31	SMI Timing	81

1 Introduction

1.1 General Description

The ADM6999U/UX is a high performance, low cost, and highly integration (Controller, PHY and Memory) eight-port 10/100 Mbps TX/FX plus one 1.6G Expansion port Ethernet switch controller with all ports supporting 10/100 Mbps Full/Half duplex switch function. The ADM6999U/UX is intended for applications to stand alone the bridge for low cost 16 Port Switch. The ADM6999UX is the environmentally friendly “green” package version.

ADM6999U/UX provides most advanced functions such as: **802.1p (Q.O.S.ADM6999U/UX), 802.1q (VLAN), Port MAC Address Locking, Management, Port Status, TP Auto-MDIX, 25M Crystal & Extra ninth Port (RMII/MII/GPSI)** functions to meet the customer’s requests on Switch demand.

The built-in 768K SRAM used for the packet buffer and address learning table is divided into 512 bytes/block to achieve the optimized memory utilization through complicated link list on packets with various lengths.

ADM6999U/UX also supports priority features by Port-Base, VLAN and IP TOS field checking. Users can easily set as different priority mode in individual port, through a small low-cost micro controller to initialize or on-the-fly to configure. Each output port supports two queues in the way of fixed N: 1 fairness queuing to fit the bandwidth demand on various types of packet such as Voice, Video and data. 802.1Q, Tag/Untag, and up to 32 groups of VLAN are also supported. ADM6999U/UX learns user define 4 or 5 bits of VLAN ID.

An intelligent address recognition algorithm makes ADM6999U/UX to recognize up to 2048 different MAC addresses and enables filtering and forwarding at full wire speed.

Port MAC address Locking function is also supported by ADM6999U/UX to use on Building Internet access to prevent multiple users share one port traffic.

1.2 Features

Main features:

- Supports eight 10M/100M auto-detect Half/Full duplex switch ports with TX/FX interfaces and one 1.6G Expansion Port.
- Built-in 12Kx64 SRAM.
- Supports 2048 MAC addresses table.
- Supports two queue for Qos.
- Supports priority features by Port-Based, 802.1p VLAN & IP TOS of packets.
- Supports Store & Forward architecture and perform forwarding and filtering at non-blocking full wire speed.
- Supports buffer allocation with 512 bytes per block.
- Supports Aging function Enable/Disable.
- Supports Serial & Scan LED mode with Power On auto diagnostic.
- Supports 802.3x Flow Control pause packet for Full Duplex in case buffer is full.
- Supports Back Pressure function for Half Duplex operation in case buffer is full.
- Supports packet length up to 1522 bytes.
- Broadcast Storming Filter function.
- Supports 802.1Q VLAN. Up to 16/32 VLAN groups is implemented by user define four/five bits of VLAN ID.
- Supports MAC-clone feature.
- Supports TP interface Auto MDIX function for auto TX/RX swap by strapping-pin.
- Easy Management 32bits smart counter for per port RX/TX byte/packet count, error count and collision count.
- Supports PHY status output for management system.
- 25M Crystal only for the whole system.
- 128 QFP package with 0.18um technology. 1.8V/3.3V power supply.

1.3 Applications

ADM6999U/UX in 128-pin PQFP:

- 16-port switch

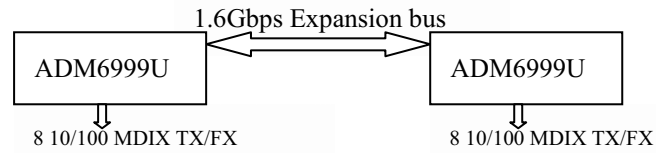

Figure 1 ADM6999U/UX's Application

2 Input and Output Signals

This chapter describes Pin Diagram and Pin Description.

2.1 Pin Diagram

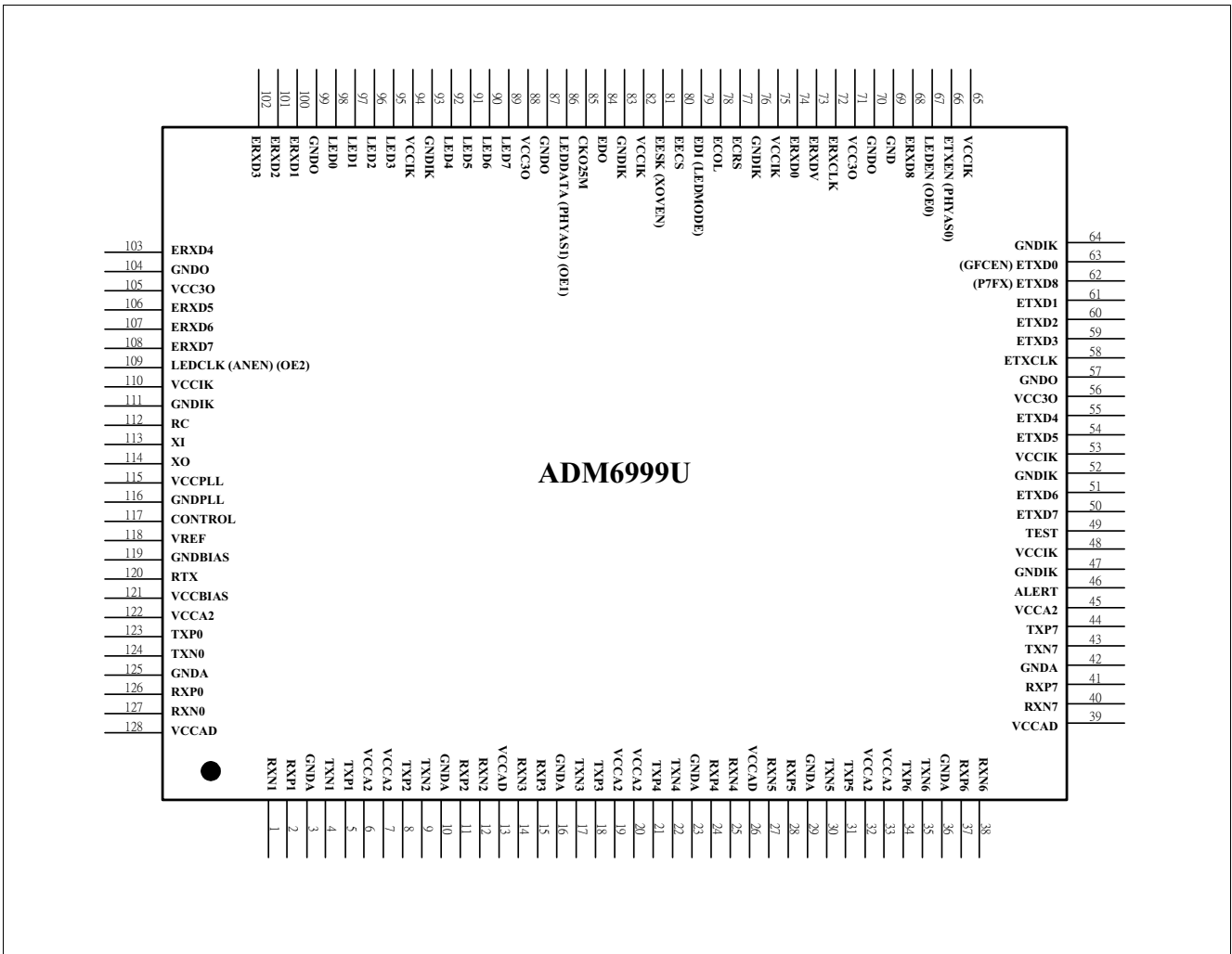

Figure 2 ADM6999U/UX 128 Pin Diagram

2.2 Pin Type and Buffer Type Abbreviations

Standardized abbreviations:

Table 1 Abbreviations for Pin Type

Abbreviations	Description
I	Standard input-only pin. Digital levels.
O	Output. Digital levels.
I/O	I/O is a bidirectional input/output signal.
AI	Input. Analog levels.
AO	Output. Analog levels.
AI/O	Input or Output. Analog levels.
PWR	Power
GND	Ground
MCL	Must be connected to Low (JEDEC Standard)
MCH	Must be connected to High (JEDEC Standard)
NU	Not Usable (JEDEC Standard)
NC	Not Connected (JEDEC Standard)

Table 2 Abbreviations for Buffer Type

Abbreviations	Description
Z	High impedance
PU1	Pull up, 10 k Ω
PD1	Pull down, 10 k Ω
PD2	Pull down, 20 k Ω
TS	Tristate capability: The corresponding pin has 3 operational states: Low, high and high-impedance.
OD	Open Drain. The corresponding pin has 2 operational states, active low and tristate, and allows multiple devices to share as a wire-OR. An external pull-up is required to sustain the inactive state until another agent drives it, and must be provided by the central resource.
OC	Open Collector
PP	Push-Pull. The corresponding pin has 2 operational states: Active-low and active-high (identical to output with no type attribute).
OD/PP	Open-Drain or Push-Pull. The corresponding pin can be configured either as an output with the OD attribute or as an output with the PP attribute.
ST	Schmitt-Trigger characteristics
TTL	TTL characteristics

2.3 Pin Description

Table 3 ADM6999U/UX 128 Pin Descriptions

Pin or Ball No.	Name	Pin Type	Buffer Type	Function
Twisted Pair Interface				
126	RXP0	AI/O		Twisted Pair Receive Input Positive
2	RXP1			
11	RXP2			
15	RXP3			
24	RXP4			
28	RXP5			
37	RXP6			
41	RXP7			
127	RXN0	AI/O		Twisted Pair Receive Input Negative
1	RXN1			
12	RXN2			
14	RXN3			
25	RXN4			
27	RXN5			
38	RXN6			
40	RXN7			
123	TXP0	AI/O		Twisted Pair Transmit Output Positive
5	TXP1			
8	TXP2			
18	TXP3			
21	TXP4			
31	TXP5			
34	TXP6			
44	TXP7			
124	TXN0	AI/O		Twisted Pair Transmit Output Negative
4	TXN1			
9	TXN2			
17	TXN3			
22	TXN4			
30	TXN5			
35	TXN6			
43	TXN7			

EBus Interfaces

Table 3 ADM6999U/UX 128 Pin Descriptions

Pin or Ball No.	Name	Pin Type	Buffer Type	Function
63	ETXD0	I/O	8mA, PU	EBus Transmit Data 0 Acts as GMII transmit data TXD0. Synchronous to the rising edge of TXCLK. Internally Pull-up. User must add pull high 1K resistor to 3.3V on 16 port application.
	GFCEN	I/O	8mA, PU	Setting GFCEN:Global Flow Control Enable At power-on-reset, latched as Full Duplex Flow control setting 0 _B , Disable flow-control 1 _B , Enable flow-control (default)
61	ETXD1	O	8mA	EBus Transmit Data bit 7~ Synchronous to the rising edge of GTXCLK.
60	ETXD2			
59	ETXD3			
55	ETXD4			
54	ETXD5			
51	ETXD6			
50	ETXD7			
62	P7FX	I/O	8mA, PD	Setting Port7 FX/TX Mode select Internal pull down. 0 _B , Port7 as TX port 1 _B , Port7 as FX port
	ETXD8	I/O	8mA, PD	EBus Transmit Data 8
66	ETXEN	I/O	8mA, PD	EBus Transmit Enable
	PHYAS0	I/O	8mA, PD	Setting PHAY0: Chip physical address 0 for multiple chip EEPROM access. Internal pull down. Power on reset value PHYAS0 combines with PHYAS1(LEDDATA). PHYAD Gigabit PHY Address 00 08 _H Master 01 09 _H Slave0 1x 18 _H Slave1(Not used) For two ADM6999U/UXs as 16port application : Master: ADM6999U/UX will read 93C46/66 EEPROM first Bank.(00 _H ~27 _H). Slave0: ADM6999U/UX will read 93C66 EEPROM second Bank.(40 _H ~67 _H). User must assert one SK cycle when CS is at idle stage and chip internal registers are being writing.

Table 3 ADM6999U/UX 128 Pin Descriptions

Pin or Ball No.	Name	Pin Type	Buffer Type	Function
74	ERXD0	I	PD	EBUS port receive data 8~0 Synchronous to the rising edge of RXCLK.
100	ERXD1			
101	ERXD2			
102	ERXD3			
103	ERXD4			
106	ERXD5			
107	ERXD6			
108	ERXD7			
68	ERXD8			
73	ERXDV	I	PD	EBUS receive data valid Internal pull down.
78	ECOL	I	PD	EBUS Collision input Internal pull down.
77	ECRS	I	PD	EBUS Port Carrier Sense Internal pull down.
58	ETXCLK	O	16mA	EBUS 125MHz clock Output
72	ERXCLK	I		EBUS Receive Clock Input
LED Interface, 11 pins				
67	Scan LED OE0	O	8mA	Scan LED Mode OE0: Scan LED Control for LINK LED
86	Serial LED LEDDATA	I/O	8mA	Serial LED Mode LEDDATA: Serial LED Data
	Scan LED OE1			Scan LED Mode OE1: Scan LED Control for Speed LED
	PHYAS1			Setting PHYAS1: Chip physical address. See pin 66 define.
109	Serial LED LEDCLK	I/O	8mA, PU	Serial LED Mode LEDCLK: Serial LED Clock
	Scan LED OE2			Scan LED Mode OE2: Scan LED Control for Duplex LED
	ANEN			Setting ANEN: On power-on-reset, latched as Auto Negotiation capability for all ports. 0 _B , Disable Auto Negotiation. 1 _B , Enable Auto Negotiation (defaulted by pulled up internally)

Table 3 ADM6999U/UX 128 Pin Descriptions

Pin or Ball No.	Name	Pin Type	Buffer Type	Function
98	LED0	I		Scan LED Data [7:0]
97	LED1			
96	LED2			
95	LED3			
92	LED4			
91	LED5			
90	LED6			
89	LED7			
92	Dual Color	I		Setting Dual Color: Serial LED mode only. Single Color Dual Color Select 0 _B , Single Color LED mode 1 _B , Dual Color LED mode.
EEPROM/Management Interface				
84	EEDO	I	TTL, PU	EEPROM Data Output Serial data input from EEPROM. This pin is internally pull-up.
80	EECS	O	4mA, PD	EEPROM Chip Select This pin is active high chip enable for EEPROM. When RC is low, it will be Tristate. This pin is internally pull-down.
81	EECK	I/O	4mA, PD	Serial Clock This pin is clock source for EEPROM.
	XOVEN	I/O	4mA, PD	Setting XOVEN: This pin is internally pull-down. On power-on-reset, latched as P7~0 Auto MDIX enable or not. Suggest externally pull up to enable Auto MDIX for all ports. 0 _B , to disable MDIX (defaulted) 1 _B , to enable MDIX
79	EEDI	O	4mA, PD	EEPROM Serial Data Input This pin is output for serial data transfer.
	LEDMODE	O	4mA, PD	Setting LEDMODE: On power-on-reset, latched as Dual Color mode or not. This pin is internal pull-down. 0 _B , to set Single color mode for LED 1 _B , to set Dual Color mode for LED
Misc.				
85	CKO25M	O	8mA	25M Clock Output
117	Control	O		FET Control Signal The pin is used to control FET for 3.3 V to 1.8 V regulator. Add 0.01 μf capacitor to GND.
120	RTX	A		TX Resistor Add 1.1K %1(A1), 1K %1 (A2) resistor to GND.
118	VREF	A		Analog Reference Voltage
112	RC	I	ST	RC Input for Power On reset Reset input pin

Table 3 ADM6999U/UX 128 Pin Descriptions

Pin or Ball No.	Name	Pin Type	Buffer Type	Function
113	XI	AI		25M Crystal Input 25M Crystal Input. Variation is limited to +/- 50ppm.
114	XO	AO		25M Crystal Output When connected to oscillator, this pin should left unconnected.
49	TEST	I	TTL	TEST Value At normal application connect to GND.
Chip Configuration				
46	ALERT	O		Alert LED Display This pin will show the status of power-on-diagnostic and broadcast traffic.
Power/Ground				
3, 10, 16, 23, 29, 36, 42, 125	GNDA	I		Ground Used by AD Block
6, 7, 19, 20, 32, 33, 45, 122	VCCA2	I		1.8 V, Power Used by TX Line Driver
13, 26, 39, 128	VCCAD	I		3.3 V, Power Used by AD Block
119	GNDBIAS	I		Ground Used by Bias Block
121	VCCBIAS	I		3.3 V, Power Used by Bias Block
116	GNDPLL	I		Ground used by PLL
115	VCCPLL	I		1.8 V, Power used by PLL
47, 52, 64, 76, 83, 93, 111	GNDIK	I		Ground Used by Digital Core
48, 53, 65, 75, 82, 94, 110	VCCIK	I		1.8 V, Power Used by Digital Core
57, 70, 87, 99, 104	GNDO	I		Ground Used by Digital Pad
56, 71, 88, 105	VCC3O	I		3.3 V, Power Used by Digital Pad
69	GND	I	TTL	Scan Enable This pin will be used as the scan enable input for testing. Connect to GND at normal application.

3 Descriptions

This chapter provides Functional Description, 10/100M PHY Block Description, Memory Block Description, Switch Functional Description, EEPROM Content and EEPROM Access Description.

3.1 Functional Description

The ADM6999U/UX integrates eight 100Base-X physical sub-layer (PHY), 100Base-TX physical medium dependent (PMD) transceivers, eight complete 10Base-T modules, 8 port 100/10 switch controller, and one 1.6G Expansion Port and memory into a single chip for both 10Mbps/s, 100Mbps/s Ethernet switch operations. It also supports 100Base-FX operation through external fiber-optic transceivers. The device is capable of operating in either Full Duplex mode or Half-Duplex mode in 10Mbps/s and 100Mbps/s. Operational modes can be selected by hardware configuration pins, software settings of management registers, or determined by the on-chip auto negotiation logic.

The ADM6999U/UX consists of three major blocks:

- 10/100M PHY Block
- Switch Controller Block
- Built-in 12Kx64 SSRAM

3.2 10/100M PHY Block Description

The 100Base-X section of the device implements the following functional blocks:

- 100Base-X physical coding sub-layer (PCS)
- 100Base-X physical medium attachment (PMA)
- Twisted-pair transceiver (PMD)

The 100Base-X and 10Base-T sections share the following functional blocks:

- Clock synthesizer module
- MII Registers
- IEEE 802.3u auto negotiation

3.2.1 100Base-X Module

The ADM6999U/UX implements 100Base-X compliant PCS, PMA and 100Base-TX compliant TP-PMD as illustrated in [Figure 3](#). Bypass options for each of the major functional blocks within the 100Base-X PCS provide flexibility for various applications. 100Mbps/s PHY loop back is included for diagnostic purpose.

3.2.2 100Base-X Receiver

The 100Base-X receiver consists of functional blocks required to recover and condition the 125Mbps/s received data stream. The ADM6999U/UX implements the 100Base-X receiving state machine diagram as given in ANSI/IEEE Standard 802.3u, Clause 24. The 125Mbps/s received data stream may originate from the on-chip twisted-pair transceiver in a 100Base-TX application. Alternatively, the received data stream may be generated by an external optical receiver as in a 100Base-FX application.

The receiver block consists of the following functional sub-blocks:

- A/D Converter
- Adaptive Equalizer and timing recovery module
- NRZI/NRZ and serial/parallel decoder
- De-scrambler
- Symbol alignment block
- Symbol Decoder
- Collision Detect Block
- Carrier sense Block

- Stream decoder block

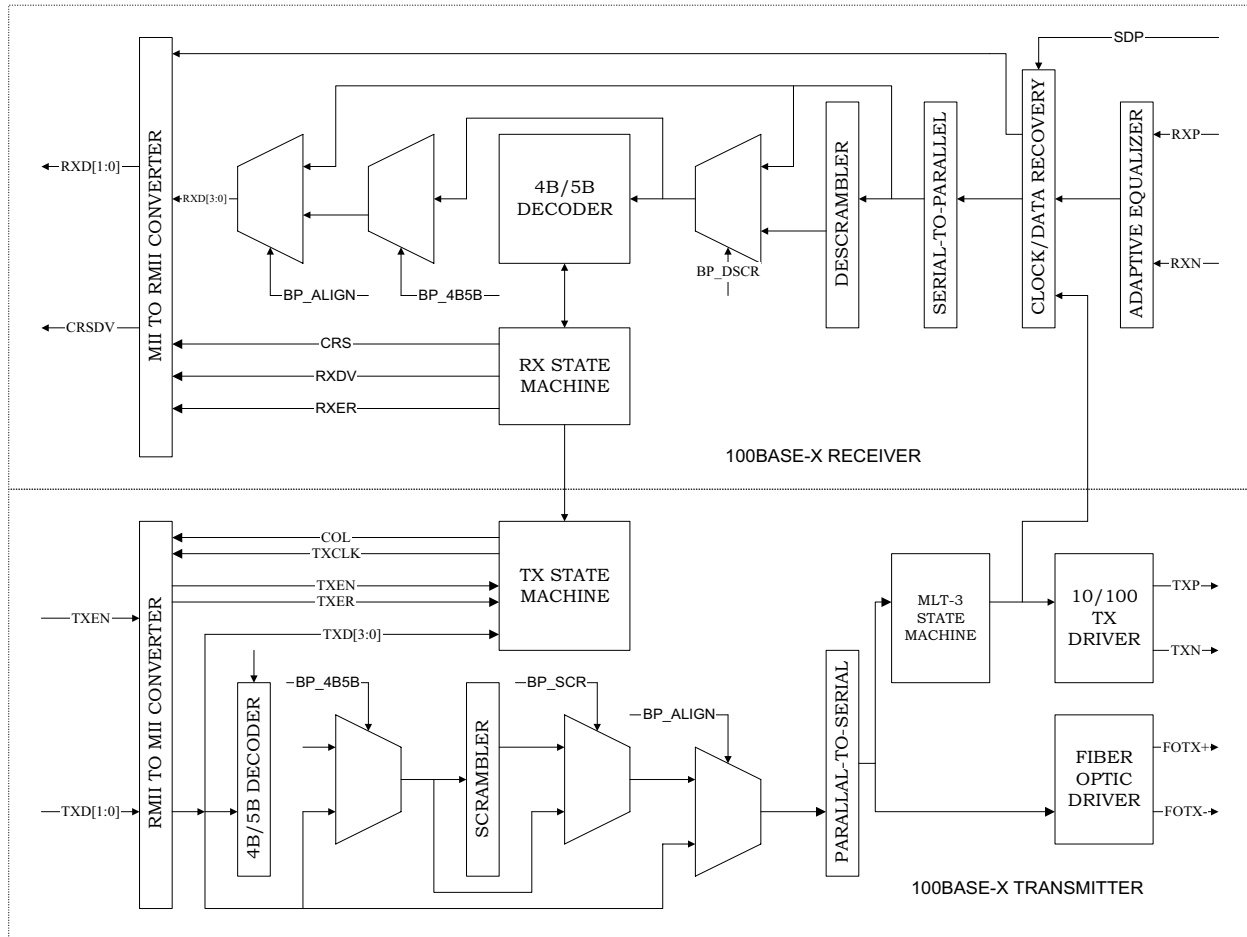

Figure 3 100Base-X Module

3.2.2.1 A/D Converter

High performance A/D converter with 125 MHz sampling rate converts signals received on RXP/RXN pins to 6 bits data streams; besides it possess auto-gain-control capability that will further improve receiving performance especially under long cable or harsh detrimental signal integrity. Due to high pass characteristic on transformer, built in base-line-wander correcting circuit will cancel it out and restore its DC level.

3.2.2.2 Adaptive Equalizer and Timing Recovery Module

All digital design is especial immune from noise environments and achieves better correlation between production and system testing. Baud rate Adaptive Equalizer/Timing Recovery compensates line loss induced from twisted pair and tracks far end clock at 125M samples per second. Adaptive Equalizer implemented with Feed forward and Decision Feedback techniques meet the requirement of BER less than 10⁻¹² for transmission on CAT5 twisted pair cable ranging from 0 to 120 meters.

3.2.2.3 NRZI/NRZ and Serial/Parallel Decoder

The recovered data is converted from NRZI to NRZ. The data is not necessarily aligned to 4B/5B code group's boundary.

3.2.2.4 Data De-scrambling

The de-scrambler acquires synchronization with the data stream by recognizing idle bursts of 40 or more bits and locking its deciphering Linear Feedback Shift Register (LFSR) to the state of the scrambling LFSR. Upon achieving synchronization, the incoming data is XORed by the deciphering LFSR and de-scrambled.

In order to maintain synchronization, the de-scrambler continuously monitors the validity of the unscrambled data that it generates. To ensure this, a link state monitor and a hold timer are used to constantly monitor the synchronization status. Upon synchronization of the de-scrambler the hold timer starts a 722 us countdown. Upon detection of sufficient idle symbols within the 722 us period, the hold timer will reset and begin a new countdown. This monitoring operation will continue indefinitely given a properly operating network connection with good signal integrity. If the link state monitor does not recognize sufficient unscrambled idle symbols within 722 us period, the de-scrambler will be forced out of the current state of synchronization and reset in order to re-acquire synchronization.

3.2.2.5 Symbol Alignment

The symbol alignment circuit in the ADM6999U/UX determines code word alignment by recognizing the /J/K delimiter pair. This circuit operates on unaligned data from the de-scrambler. Once the /J/K symbol pair (11000 10001) is detected, subsequent data is aligned on a fixed boundary.

3.2.2.6 Symbol Decoding

The symbol decoder functions as a look-up table that translates incoming 5B symbols into 4B nibbles. The symbol decoder first detects the /J/K symbol pair preceded by idle symbols and replaces the symbol with MAC preamble. All subsequent 5B symbols are converted to the corresponding 4B nibbles for the duration of the entire packet. This conversion ceases upon the detection of the /T/R symbol pair denoting the end of stream delimiter (ESD). The translated data is presented on the internal RXD[3:0] signal lines with RXD[0] represents the least significant bit of the translated nibble.

3.2.2.7 Valid Data Signal

The valid data signal (RXDV) indicates that recovered and decoded nibbles are being presented on the internal RXD[3:0] synchronous to receive clock, RXCLK. RXDV is asserted when the first nibble of translated /J/K is ready for transfer over the internal MII. It remains active until either the /T/R delimiter is recognized, link test indicates failure, or no signal is detected. On any of these conditions, RXDV is de-asserted.

3.2.2.8 Receive Errors

The RXER signal is used to communicate receiver error conditions. While the receiver is in a state of holding RXDV asserted, the RXER will be asserted for each code word that does not map to a valid code-group.

3.2.2.9 100Base-X Link Monitor

The 100Base-X link monitor function allows the receiver to ensure that reliable data is being received. Without reliable data reception, the link monitor will halt both transmitting and receiving operations until such time that a valid link is detected.

The ADM6999U/UX performs the link integrity test as outlined in IEEE 100Base-X (Clause 24) link monitor state diagram. The link status is multiplexed with 10Mbps/s link status to form the reportable link status bit in serial management register 1_H, and driven to the LNKACT pin.

When persistent signal energy is detected on the network, the logic moves into a Link-Ready state after approximately 500 us, and waits for an enable from the auto negotiation module. When receiving, the link-up state is entered, and the transmission and reception logic blocks become active. Should auto negotiation be disabled, the link integrity logic moves immediately to the link-up state after entering the link-ready state.

3.2.2.10 Carrier Sense

Carrier sense (CRS) for 100Mbps/s operation is asserted upon the detection of two noncontiguous zeros occurring within any 10-bit boundary of the received data stream.

The carrier sense function is independent of symbol alignment. In switch mode, CRS is asserted during either packet transmission or reception. For repeater mode, CRS is asserted only during packet reception. When the idle symbol pair is detected in the received data stream, CRS is de-asserted. In repeater mode, CRS is only asserted due to receive activity. CRS is intended to encapsulate RXDV.

3.2.2.11 Bad SSD Detection

A bad start of stream delimiter (Bad SSD) is an error condition that occurs in the 100Base-X receiver if carrier is detected (CRS asserted) and a valid /J/K set of code-group (SSD) is not received.

If this condition is detected, then the ADM6999U/UX will assert RXER and present $RXD[3:0] = 1110$ to the internal MII for the cycles hat corresponding to the received 5B code-groups until at least two idle code-groups are detected. Once at least two idle code groups are detected, RXER and CRS become de-asserted.

3.2.2.12 Far-End Fault

Auto negotiation provides a mechanism for transferring information from the Local Station to the link Partner that a remote fault has occurred for 100Base-TX. As auto negotiation is not currently specified for operation over fiber, the far end fault indication function (FEFI) provides this capability for 100Base-FX applications.

A remote fault is an error in the link that one station can detect while the other cannot. An example of this is a disconnected wire at a station's transmitter. This station will be receiving valid data and detect that the link is good via the link integrity monitor, but will not be able to detect that its transmission is not propagating to the other station.

A 100Base-FX station that detects such a remote fault may modify its transmitted idle stream from all ones to a group of 84 ones followed by a single 0. This is referred to as the FEFI idle pattern.

3.2.3 100Base-TX Transceiver

ADM6999U/UX implements a TP-PMD compliant transceiver for 100Base-TX operation. The differential transmitting driver is shared by the 10Base-T and 100Base-TX subsystems. This arrangement results in one device that uses the same external magnetic for both the 10Base-T and the 100Base-TX transmission with simple RC component connections. The individually wave-shaped 10Base-T and 100Base-TX transmitting signals are multiplexed in the transmission output driver selection.

3.2.3.1 Transmit Drivers

The ADM6999U/UX 100Base-TX transmission driver implements MLT-3 translation and wave-shaping functions. The rise/fall time of the output signal is closely controlled to conform to the target range specified in the ANSI TP-PMD standard.

3.2.3.2 Twisted-Pair Receiver

For 100Base-TX operation, the incoming signal is detected by the on-chip twisted-pair receiver that consists of a differential line receiver, an adaptive equalizer and a base-line wander compensation circuits.

The ADM6999U/UX uses an adaptive equalizer that changes filter frequency response in accordance with cable length. The cable length is estimated based on the incoming signal strength. The equalizer tunes itself automatically for any cable length to compensate for the amplitude and phase distortions incurred from the cable.

3.2.4 10Base-T Module

The 10Base-T Transceiver Module is IEEE 802.3 compliant. It includes the receiver, transmitter, collision, heartbeat, loop back, jabber, wave shaper, and link integrity functions, as defined in the standard.

The ADM6999U/UX 10Base-T module is comprised of the following functional blocks:

- Manchester encoder and decoder
- Collision detector
- Link test function
- Transmit driver and receiver
- Serial and parallel interface
- Jabber and SQE test functions
- Polarity detection and correction

3.2.4.1 Operation Modes

The ADM6999U/UX 10Base-T module is capable of operating in either half-duplex mode or full-duplex mode. In half-duplex mode, the ADM6999U/UX functions as an IEEE 802.3 compliant transceiver with fully integrated filtering. The COL signal is asserted during collisions or jabber events, and the CRS signal is asserted during transmitting and receiving. In full duplex mode the ADM6999U/UX can simultaneously transmit and receive data.

3.2.4.2 Manchester Encoder/Decoder

Data encoding and transmission begin when the transmission enable input (TXEN) goes high and continues as long as the transceiver is in good link state. Transmission ends when the transmission enable input goes low. The last transition occurs at the center of the bit cell if the last bit is a 1, or at the boundary of the bit cell if the last bit is 0. Decoding is accomplished by a differential input receiver circuit and a phase-locked loop that separate the Manchester-encoded data stream into clock signals and NRZ data. The decoder detects the end of a frame when no more mid bit transitions are detected. Within one and half bit times after the last bit, carrier sense is de-asserted.

3.2.4.3 Transmit Driver and Receiver

The ADM6999U/UX integrates all the required signal conditioning functions in its 10Base-T block such that external filters are not required. Only one isolation transformer and impedance matching resistors are needed for the 10Base-T transmitting and receiving interface. The internal transmitting filtering ensures that all the harmonics in the transmission signal are attenuated properly.

3.2.4.4 Smart Squelch

The smart squelch circuit is responsible for determining when valid data is present on the differential reception. The ADM6999U/UX implements an intelligent receiving squelch on the RXP/RXN differential inputs to ensure that impulse noise on the receiving inputs will not be mistaken for a valid signal. The squelch circuitry employs a combination of amplitude and timing measurements (as specified in the IEEE 802.3 10Base-T standard) to determine the validity of data on the twisted-pair inputs.

The signal at the start of the packet is checked by the analog squelch circuit and any pulses not exceeding the squelch level (either positive or negative, depending upon polarity) will be rejected. Once this first squelch level is overcome correctly, the opposite squelch level must then be exceeded within 150ns. Finally, the signal must exceed the original squelch level within an additional 150ns to ensure that the input waveform will not be rejected.

Only after all these conditions have been satisfied will a control signal be generated to indicate to the remainder of the circuitry that valid data is present.

Valid data is considered to be present until the squelch level has not been generated for a time longer than 200 ns, indicating end of packet. Once good data has been detected, the squelch levels are reduced to minimize the effect

of noise, causing premature end-of-packet detection. The receiving squelch threshold level can be lowered for use in longer cable applications. This is achieved by setting bit 10 of register address 11_H.

3.2.5 Carrier Sense

Carrier Sense (CRS) is asserted due to receive activity once valid data is detected via the smart squelch function. For 10 Mbits/s half duplex operation, CRS is asserted during either packet transmission or reception. For 10 Mbits/s full duplex and repeater mode operations, the CRS is asserted only due to receive activity.

3.2.6 Jabber Function

The jabber function monitors the ADM6999U/UX output and disables the transmitter if it attempts to transmit a longer than legal sized packet. If TXEN is high for greater than 24ms, the 10Base-T transmitter will be disabled. Once disabled by the jabber function, the transmitter stays disabled for the entire time that the TXEN signal is asserted. This signal has to be de-asserted for approximately 256 ms (The un-jab time) before the jabber function re-enables the transmit outputs. The jabber function can be disabled by programming bit 4 of register address 10_H to high.

3.2.7 Link Test Function

A link pulse is used to check the integrity of the connection with the remote end. If valid link pulses are not received, the link detector disables the 10Base-T twisted-pair transmitter, receiver, and collision detection functions.

The link pulse generator produces pulses as defined in IEEE 802.3 10Base-T standard. Each link pulse is nominally 100ns in duration and is transmitted every 16 ms, in the absence of transmitting data.

3.2.8 Automatic Link Polarity Detection

ADM6999U/UX's 10Base-T transceiver module incorporates an "automatic link polarity detection circuit". The inverted polarity is determined when seven consecutive link pulses of inverted polarity or three consecutive packets are received with inverted end-of-packet pulses. If the input polarity is reversed, the error condition will be automatically corrected and reported in bit 5 of register 10_H.

3.2.9 Clock Synthesizer

The ADM6999U/UX implements a clock synthesizer that generates all the reference clocks needed from a single external frequency source. The clock source must be a TTL level signal at 25 MHz +/- 50ppm

3.2.10 Auto Negotiation

The Auto Negotiation function provides a mechanism for exchanging configuration information between two ends of a link segment and automatically selecting the highest performance mode of operations supported by both devices. Fast Link Pulse (FLP) Bursts provide the signaling used to communicate auto negotiation abilities between two devices at each end of a link segment. For further detail regarding auto negotiation, refer to Clause 28 of the IEEE 802.3u specification. The ADM6999U/UX supports four different Ethernet protocols, so the inclusion of auto negotiation ensures that the highest performance protocol will be selected based on the ability of the link partner.

Highest priority relative to the following list:

1. 100Base-TX full duplex (highest priority)
2. 100Base-TX half duplex
3. 10Base-T full duplex
4. 10Base-T half duplex (lowest priority)

3.3 Memory Block Description

ADM6999U/UX builds in 768K bits memory inside. Memory buffer is divided as two blocks. One is MAC addressing table and another one is data buffer.

MAC address Learning Table size is 2048 entries with each entry occupying eight bytes length. These eight bytes data include 6 bytes source address, VLAN information, Port information and Aging counter.

Data buffer is divided into 512 bytes/block. ADM6999U/UX buffer management is per port fixed block number and all port share one global buffer. This architecture can get better memory utilization and network balance on different speed and duplex test conditions.

Received packet will separate as several 512 bytes/block and chain together. If packet size more than 512 bytes then ADM6999U/UX will chain two or more blocks to store receiving packet.

3.4 Switch Functional Description

The ADM6999U/UX uses a “store & forward” switching approach for the following reason:

Store & forward switches allow switching between different speed media (e.g. 10BaseX and 100BaseX). Such switches require the large elastic buffer especially bridging between a server on a 100Mbps network and clients on a 10Mbps segment.

Store & forward switches improve overall network performance by acting as a “network cache”

Store & forward switches prevent the forwarding of corrupted packets by the frame check sequence (FCS) before forwarding to the destination port.

3.4.1 Basic Operation

The ADM6999U/UX receives incoming packets from one of its ports, searches in the Address Table for the Destination MAC Address and then forwards the packet to the other port within the same VLAN group, if appropriate. If the destination address is not found in the address table, the ADM6999U/UX treats the packet as a broadcast packet and forwards the packet to the other ports which in the same VLAN group.

The ADM6999U/UX automatically learns the port number of attached network devices by examining the Source MAC Address of all incoming packets at wire speed. If the Source Address is not found in the Address Table, the device adds it to the table.

3.4.1.1 Address Learning

The ADM6999U/UX uses a hash algorithm to learn the MAC address and can learn up to 2K MAC addresses. Address is stored in the Address Table. The ADM6999U/UX searches for the Source Address (SA) of an incoming packet in the Address Table and acts as below:

If the SA was not found in the Address Table (a new address), the ADM6999U/UX waits until the end of the packet (non-error packet) and updates the Address Table. If the SA was found in the Address Table, then aging value of each corresponding entry will be reset to 0.

When the DA is PAUSE command, then the learning process will be disabled automatically by ADM6999U/UX.

3.4.1.2 Address Recognition and Packet Forwarding

The ADM6999U/UX forwards the incoming packets between bridged ports according to the Destination Address (DA) as below. All the packet forwarding will check VLAN first. A forwarding port must be within the same VLAN as the source port.

1. If the DA is an UNICAST address and the address was found in the Address Table, the ADM6999U/UX will check the port number and acts as follows:
 - a) If the port number is equal to the port on which the packet was received, the packet is discarded.
 - b) If the port number is different, the packet is forwarded across the bridge.

2. If the DA is an UNICAST address and the address was not found, the ADM6999U/UX treats it as a multicast packet and forwards across the bridge.
3. If the DA is a Multicast address, the packet is forwarded across the bridge.
4. If the DA is PAUSE Command (01-80-C2-00-00-01), then this packet will be dropped by ADM6999U/UX. ADM6999U/UX can issue and learn PAUSE command.
5. ADM6999U/UX will forward the packet with DA of (01-80-C2-00-00-00), filter out the packet with DA of (01-80-C2-00-00-01), and forward the packet with DA of (01-80-C2-00-00-02 ~ 01-80-C2-00-00-0F)

3.4.1.3 Address Aging

Address aging is supported for topology changes such as an address moving from one port to the other. When this happens, the ADM6999U/UX internally has a 300 seconds timer will aged out (remove) the address from the address table. Aging function can be enabled/disabled by user. Normally, disabling aging function is for security purpose.

3.4.1.4 Back off Algorithm

The ADM6999U/UX implements the truncated exponential back off algorithm compliant to the IEEE802.3 CSMA/CD standard. ADM6999U/UX will restart the back off algorithm by choosing 0-9 collision counts. The ADM6999U/UX resets the collision counter after 16 consecutive retransmit trials.

3.4.1.5 Inter-Packet Gap (IPG)

IPG is the idle time between any two successive packets from the same port. The typical number is 96-bits time. The value is 9.6 μ s for 10Mbps ETHERNET, and 960ns for 100Mbps fast ETHERNET. ADM6999U/UX provides the option of a 92-bit gap in EEPROM to prevent packet lost when Flow Control is turned off and clock P.P.M. value differs.

3.4.1.6 Illegal Frames

The ADM6999U/UX will discard all illegal frames such as runt packet (less than 64 bytes), oversize packet (greater than 1518 or 1522 bytes) and bad CRC. Dribbling packing with good CRC value will accept by ADM6999U/UX. In case of bypass mode enabled, ADM6999U/UX will support tag and untagged packets with size up to 1522 bytes. In case of non-bypass mode, ADM6999U/UX will support tag packets up to 1526bytes, and untagged packets up to 1522bytes.

3.4.1.7 Half Duplex Flow Control

Back Pressure function is supported for half-duplex operation. When the ADM6999U/UX cannot allocate a receiving buffer for an incoming packet (buffer full), the device will transmit a jam pattern on the port, thus forcing a collision. Back Pressure is enabled by the BPEN set during RESET asserting. An Infineon-ADMtek Co Ltd proprietary algorithm is implemented inside the ADM6999U/UX to prevent back pressure function causing HUB partitioned under heavy traffic environment and reduce the packet lost rate to increase the whole system performance.

3.4.1.8 Full Duplex Flow Control

When full duplex port runs out of its receiving buffer, a PAUSE packet command will be issued by ADM6999U/UX to notice the packet sender to pause transmission. This frame based flow control is totally compliant to IEEE 802.3x. ADM6999U/UX can issue or receive pause packet.

3.4.1.9 Broadcast Storm Filter

If Broadcast Storming filter is enable, the broadcast packets over the rising threshold within 50 ms will be discarded by the threshold setting. See EEPROM Reg.10_H.

Broadcast storm mode after initial:

Time interval: 50 ms

The max. packet number = 7490 in 100Base, 749 in 10Base

Table 4 Port Rising/Falling Threshold

Per Port Rising Threshold				
	00	01	10	11
All 100TX	Disable	10%	20%	40%
Not All 100TX	Disable	1%	2%	4%

Per Port Falling Threshold				
	00	01	10	11
All 100TX	Disable	5%	10%	20%
Not All 100TX	Disable	0.5%	1%	2%

3.4.2 Auto TP MDIX Function

At normal application which Switch connect to NIC card is by one by one TP cable. If Switch connects other device such as another Switch must by two way. First one is Cross Over TP cable. Second way is to use extra RJ45 which crossover internal TX+- and RX+- signal. By second way customers can use one by one cable to connect two Switch devices. All these efforts need extra cost and are not good solutions. ADM6999U/UX provides Auto MDIX function which can adjust TX+- and RX+- at correct pin. Users can use one by one cable between ADM6999U/UX and other device. This function can be Enable/Disable by hardware pin and EEPROM configuration register 01_H~09_H bit 15. If hardware pin set all port at Auto MDIX mode then EEPROM setting is useless. If the hardware pin sets all port at non Auto MDIX mode then EEPROM can set each port this function enable or disable.

3.4.3 Port Locking

Port locking function will provide customers a simple way to limit per port user number to one. If this function is turned on then ADM6999U/UX will lock first MAC address in learning table. After this MAC address locking will never age out except Reset signal. Another MAC address which is not the same as locking one will be dropped. ADM6999U/UX provides one MAC address per port. This function is per port setting. When turning on Port Locking function, recommend customer to turn off aging function. See EEPROM register 12_H bit 0~8.

3.4.4 VLAN Setting & Tag/Untag & Port-base VLAN

ADM6999U/UX supports bypass mode and untagged port as default setting while the chip is power-on. Thus, every packet with or without tag will be forwarding to the destination port without any modification by ADM6999U/UX. Meanwhile port-base VLAN could be enabled according to the PVID value (user define 4bits to map 16 groups written at register 13_H to register 22_H) of the configuration content of each port.

ADM6999U/UX also supports 16 802.1Q VLAN groups. In VLAN four bytes tag include twelve VLAN ID. ADM6999U/UX learns user define four bits of VID. If users need to use this function, two EEPROM registers are needed to be programmed first:

- Port VID number at EEPROM register 01_H~09_H bit 13~10, register 28_H~2B_H and register 2C_H bit 7~0:
ADM6999U/UX will check coming packet. If coming packet is non VLAN packet then ADM6999U/UX will use PVID as VLAN group reference. ADM6999U/UX will use packet's VLAN value when receiving tagged packet.

- VLAN Group Mapping Register. EEPROM register 013_H~022_H define VLAN grouping value. Users use these register to define VLAN group.

Users can define each port as Tag port or Untag port by Configuration register Bit 4. The operation of packet between Tag port and Untag port can explain by follow example:

Example1: Port receives Untag packet and send to Untag port

ADM6999U/UX will check the port user define four bits of VLAN ID first then check VLAN group resister. If the destination port is in the same VLAN as the receiving port then this packet will forward to the destination port without any change. If the destination port is not in the same VLAN as the receiving port then this packet will be dropped.

Example2: Port receives Untag packet and send to Tag port

ADM6999U/UX will check the port user define fours bits of VLAN ID first then check VLAN group resister. If the destination port is in the same VLAN as the receiving port than this packet will forward to the destination port with four byte VLAN Tag and new CRC. If the destination port is not in the same VLAN as the receiving port then this packet will be dropped.

Example3: Port receives Tag packet and send to Untag port

ADM6999U/UX will check the packet VLAN ID first then check VLAN group resister. If the destination port is in the same VLAN as the receiving port than this packet will forward to the destination port after removing four bytes with new CRC error. If the destination port is not in the same VLAN as the receiving port then this packet will be dropped.

Example4: Port receives Tag packet and send to Tag port

ADM6999U/UX will check the user define packet VLAN ID first then check VLAN group resister. If the destination port is in the same VLAN as the receiving port than this packet will forward to the destination port without any change. If the destination port is not in the same VLAN as the receiving port then this packet will be dropped.

3.4.5 Priority Setting

It is a trend that data, voice and video will be put on networking, Switch not only deals data packet but also provides service of multimedia data. ADM6999U/UX provides two priority queues on each port with N:1 rate. See EEPROM Reg. 10_H.

This priority function can set three ways as below:

- By Port Base: Set specific port at specific queue. ADM6999U/UX only checks the port priority and does not check packet's content VLAN and TOS at bypass mode.
- By VLAN first: ADM6999U/UX checks VLAN three priority bit first then IP TOS priority bits. Chip must be set at Tag mode.
- By IP TOS first: ADM6999U/UX checks IP TOS three priority bit first then VLAN three priority bits. Chip must be set at Tag mode.

If the port sets at VLAN/TOS priority but the receiving packet is without VLAN or TOS information then port base priority will be used.

3.4.6 LED Display

The ADM6999U/UX provides two different interfaces to drive the status to the LEDs. Each interface supports visibility per port of port speed, combined transmitting and receiving activity, and duplex collision status. Different interfaces and it color mode are applied according to LEDMODE pin and the configuration of the ADM6999U/UX latched during the power on reset.

Table 5 LED Display

Configuration	LED Mode	Interface utilized
ADM6999U /UX	1: serial interface 0: scan interface	Serial Interface: Totally two pins, LEDCLK, and LEDDATA are used to output the LED status. Scan Interface: Three control and eight LED status pins are used to output the phy status.

3.4.6.1 Serial LED Interface

A two pins interface, LEDDATA and LEDCLK, provides external shift register to capture the LED status indicated by the ADM6999U/UX. The status is encapsulated within the shift sequence, which is a consecutive stream of 8-bit status words. The first word is the DUPCOL status, the second is the speed status, and the last is the LNKACT status. Each word contains 8 bits and each bit corresponds to each port of the designated LED status. The designated LED status is sent first followed by port1 then port 2, etc.. The shift sequence is repeated every 40 ms and each bit last 640ns. [Figure 4](#) shows the external circuit.

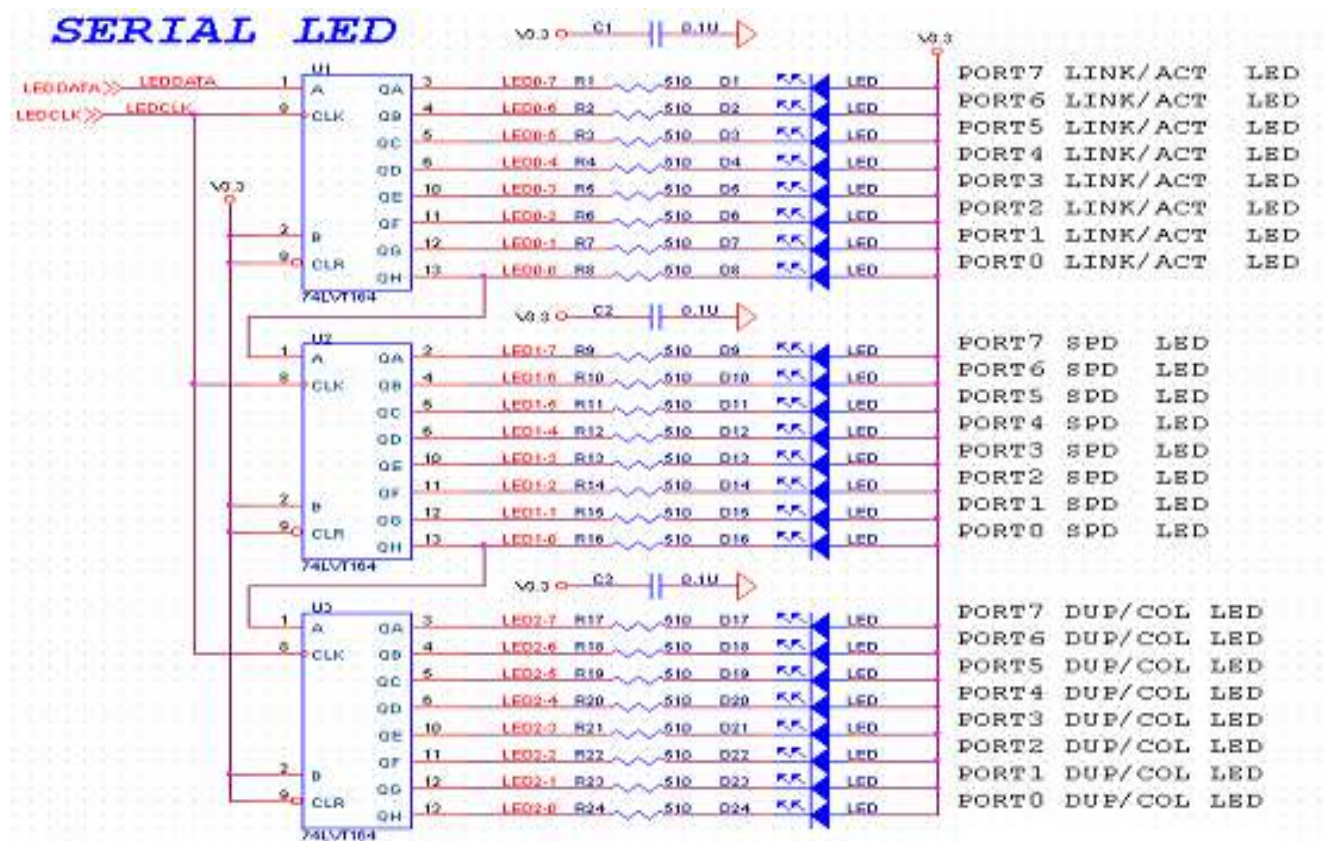

Figure 4 Serial LED Interface

3.4.6.2 Scan LED Interface

This interface is specific and it is only applied in the Ebus mode. It uses three control and 8 LED output pins to display the PHY status. Using this interface can lower the system cost effectively. [Figure 5](#) shows the external circuit.

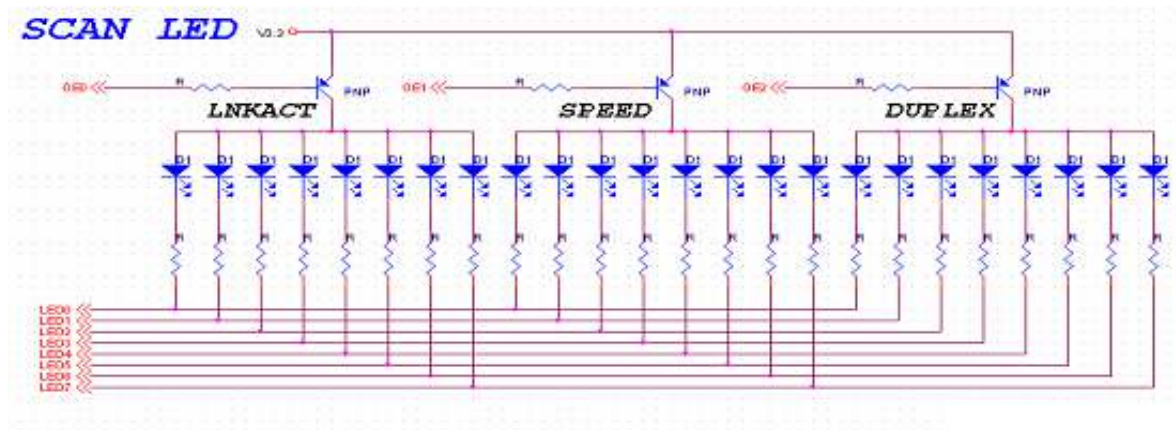

Figure 5 Scan LED Interface

Table 6 LED Corresponding Interface

Configuration		LEDMODE	Interface utilized
ADM6999U/UX	8+1MII	1: dual color 0: single color	Serial Interface. Totally two pins, LEDCLK, and LEDDATA are used to output the LED status.
ADM6999U/UX	8+1 GPSI 8+1 RMII	1: dual color 0: single color	Parallel Interface. Three pins per port are used to output the LED status types.

3.5 EEPROM Content

EEPROM provides ADM6999U/UX many options setting such as:

- Port Configuration: Speed, Duplex, Flow Control Capability and Tag/Untag
- VLAN & TOS Priority Mapping
- Broadcast Storming rate and Trunk
- Fiber Select, Auto MDIX select
- VLAN Mapping
- Per Port Buffer number

Table 7 EEPROM Register Map

Register	Bit 15-8	Bit 7-0	Default Value
00 _H	Signature		4154 _H
01 _H	Port 0 Configuration		040F _H
02 _H	Port 1 Configuration		040F _H
03 _H	Port 2 Configuration		040F _H
04 _H	Port 3 Configuration		040F _H
05 _H	Port 4 Configuration		040F _H
06 _H	Port 5 Configuration		040F _H
07 _H	Port 6 ConfigurationADM6999U/UX		040F _H
08 _H	Port 7 Configuration		040F _H
09 _H	Expansion Port Configuration		040F _H
0A _H	VID 0,1 option	Expansion Port Configuration	5902 _H
0B _H	Configuration Regsiter		8000 _H
0C _H	Reserved		FA50 _H
0D _H	Reserved		FA50 _H
0E _H	VLAN priority Map High	VLAN priority Map Low	5500 _H
0F _H	TOS priority Map High	TOS priority Map Low	5500 _H
10 _H	Miscellaneous Configuration 0		0040 _H
11 _H	Miscellaneous Configuration 1		FF00 _H
12 _H	Miscellaneous Configuration 2		3600 _H
13 _H	VLAN 0 outbound Port Map or VLAN 1 outbound Port Map	VLAN 0 outbound Port Map or VLAN 0 outbound Port Map	FFFF _H
14 _H	VLAN 1 outbound Port Map or VLAN 3 outbound Port Map	VLAN 1 outbound Port Map or VLAN 2 outbound Port Map	FFFF _H
15 _H	VLAN 2 outbound Port Map or VLAN 5 outbound Port Map	VLAN 2 outbound Port Map or VLAN 4 outbound Port Map	FFFF _H
16 _H	VLAN 3 outbound Port Map or VLAN 7 outbound Port Map	VLAN 3 outbound Port Map or VLAN 6 outbound Port Map	FFFF _H
17 _H	VALN 4 outbound Port Map or VLAN 9 outbound Port Map	VLAN 4 outbound Port Map or VLAN 8 outbound Port Map	FFFF _H

Table 7 EEPROM Register Map

Register	Bit 15-8	Bit 7-0	Default Value
18 _H	VLAN 5 outbound Port Map or VLAN 11 outbound Port Map	VLAN 5 outbound Port Map or VLAN 10 outbound Port Map	FFFF _H
19 _H	VLAN 6 outbound Port Map or VLAN 13 outbound Port Map	VLAN 6 outbound Port Map or VLAN 12 outbound Port Map	FFFF _H
1A _H	VLAN 7 outbound Port Map or VLAN 15 outbound Port Map	VLAN 7 outbound Port Map or VLAN 14 outbound Port Map	FFFF _H
1B _H	VLAN 8 outbound Port Map or VLAN 17 outbound Port Map	VLAN 8 outbound Port Map or VLAN 16 outbound Port Map	FFFF _H
1C _H	VLAN 9 outbound Port Map or VLAN 19 outbound Port Map	VLAN 9 outbound Port Map or VLAN 18 outbound Port Map	FFFF _H
1D _H	VLAN 10 outbound Port Map or VLAN 21 outbound Port Map	VLAN 10 outbound Port Map or VLAN 20 outbound Port Map	FFFF _H
1E _H	VLAN 11 outbound Port Map or VLAN 23 outbound Port Map	VLAN 11 outbound Port Map or VLAN 22 outbound Port Map	FFFF _H
1F _H	VLAN 12 outbound Port Map or VLAN 25 outbound Port Map	VLAN 12 outbound Port Map or VLAN 24 outbound Port Map	FFFF _H
20 _H	VLAN 13 outbound Port Map or VLAN 27 outbound Port Map	VLAN 13 outbound Port Map or VLAN 26 outbound Port Map	FFFF _H
21 _H	VLAN 14 outbound Port Map or VLAN 29 outbound Port Map	VLAN 14 outbound Port Map or VLAN 28 outbound Port Map	FFFF _H
22 _H	VLAN 15 outbound Port Map or VLAN 31 outbound Port Map	VLAN 15 outbound Port Map or VLAN 30 outbound Port Map	FFFF _H
23 _H	P1 Buffer Threshold Control	P0 Buffer Threshold Control	0000 _H
24 _H	P3 Buffer Threshold Control	P2 Buffer Threshold Control	0000 _H
25 _H	P5 Buffer Threshold Control	P4 Buffer Threshold Control	0000 _H
26 _H	P7 Buffer Threshold Control	P6 Buffer Threshold Control	0000 _H
27 _H	Total Buffer Threshold Control	P8 Buffer Threshold Control	0000 _H
28 _H	P1 PVID [11:4]	P0 PVID [11:4]	0000 _H
29 _H	P3 PVID [11:4]	P2 PVID [11:4]	0000 _H
2A _H	P5 PVID [11:4]	P4 PVID [11:4]	0000 _H
2B _H	P7 PVID [11:4]	P6 PVID [11:4]	0000 _H
2C _H	VLAN Group Configuration	P8 PVID [11:4]	D000 _H
2D _H	Reserved		4442 _H

3.5.1 EEPROM Registers Overview

Table 8 Registers Address Space Registers Address Space

Module	Base Address	End Address	Note
EEPROM	00 _H	2C _H	

Table 9 Registers Overview

Register Short Name	Register Long Name	Offset Address	Page Number
SR	Signature Register	00 _H	33
PCR_0	Port Configuration Register 0	01 _H	34
PCR_1	Port 1 Configuration Register	02 _H	35
PCR_2	Port 2 Configuration Register	03 _H	35
PCR_3	Port 3 Configuration Register	04 _H	35
PCR_4	Port 4 Configuration Register	05 _H	35
PCR_5	Port 5 Configuration Register	06 _H	35
PCR_6	Port 6 Configuration Register	07 _H	35
PCR_7	Port 7 Configuration Register	08 _H	35
PCR_8	Port 8 Configuration Register	09 _H	35
GPCR	Gigabit Port Configuration Register	0A _H	36
CR	Configuration Register	0B _H	37
VLAN_PMR	VLAN Priority Map Register	0E _H	38
TOS_PMR	TOS Priority Map Register	0F _H	39
MCR_0	Miscellaneous Configuration Register 0	10 _H	41
VLAN_MSR	VLAN Mode Select Register	11 _H	43
MCR_2	Miscellaneous Configuration Register 2	12 _H	46
VLAN_MTR_0	VLAN Mapping Table Register 0	13 _H	47
VLAN_MTR	VLAN Mapping Table Registers	13 _H	48
VLAN_MTR_1	VLAN Mapping Table Register 1	14 _H	49
VLAN_MTR_2	VLAN Mapping Table Register 2	15 _H	49
VLAN_MTR_3	VLAN Mapping Table Register 3	16 _H	49
VLAN_MTR_4	VLAN Mapping Table Register 4	17 _H	49
VLAN_MTR_5	VLAN Mapping Table Register 5	18 _H	49
VLAN_MTR_6	VLAN Mapping Table Register 6	19 _H	49
VLAN_MTR_7	VLAN Mapping Table Register 7	1A _H	49
VLAN_MTR_8	VLAN Mapping Table Register 8	1B _H	49
VLAN_MTR_9	VLAN Mapping Table Register 9	1C _H	49
VLAN_MTR_10	VLAN Mapping Table Register 10	1D _H	49
VLAN_MTR_11	VLAN Mapping Table Register 11	1E _H	49
VLAN_MTR_12	VLAN Mapping Table Register 12	1F _H	49
VLAN_MTR_13	VLAN Mapping Table Register 13	20 _H	49
VLAN_MTR_14	VLAN Mapping Table Register 14	21 _H	49
VLAN_MTR_15	VLAN Mapping Table Register 15	22 _H	49

Table 9 Registers Overview (cont'd)

Register Short Name	Register Long Name	Offset Address	Page Number
PBTCR_P01	Port Buffer Threshold Control Reg. P0, P1	23 _H	50
PBTCR_P23	Port Buffer Threshold Control Reg. P2, P3	24 _H	50
PBTCR_P45	Port Buffer Threshold Control Reg. P4, P5	25 _H	51
PBTCR_P67	Port Buffer Threshold Control Reg. P6, P7	26 _H	51
TBTCR	Total Buffer Threshold Control Register	27 _H	52
PVID11_4_CR_P01	Port0, 1 PVID bit11~4 Configuration Register	28 _H	53
PVID11_4_CR_P23	Port2, 3 PVID bit11~4 Configuration Register	29 _H	54
PVID11_4_CR_P45	Port4, 5 PVID bit 11~4 Configuration Register	2A _H	55
PVID11_4_CR_P67	Port6, 7 PVID bit 11~4 Configuration Register	2B _H	56
PVID11_4_VLAN_CR	P8 PVID bit 11~4/VLAN Group Shift Bits Conf.	2C _H	56

The register is addressed wordwise.

Table 10 Register Access Types

Mode	Symbol	Description HW	Description SW
read/write	rw	Register is used as input for the HW	Register is read and writable by SW
read	r	Register is written by HW (register between input and output -> one cycle delay)	Value written by software is ignored by hardware; that is, software may write any value to this field without affecting hardware behavior (= Target for development.)
Read only	ro	Register is set by HW (register between input and output -> one cycle delay)	SW can only read this register
Read virtual	rv	Physically, there is no new register, the input of the signal is connected directly to the address multiplexer.	SW can only read this register
Latch high, self clearing	lhsc	Latch high signal at high level, clear on read	SW can read the register
Latch low, self clearing	llsc	Latch high signal at low-level, clear on read	SW can read the register
Latch high, mask clearing	lhmk	Latch high signal at high level, register cleared with written mask	SW can read the register, with write mask the register can be cleared (1 clears)
Latch low, mask clearing	llmk	Latch high signal at low-level, register cleared on read	SW can read the register, with write mask the register can be cleared (1 clears)
Interrupt high, self clearing	ihsc	Differentiate the input signal (low->high) register cleared on read	SW can read the register
Interrupt low, self clearing	ilsc	Differentiate the input signal (high->low) register cleared on read	SW can read the register
Interrupt high, mask clearing	ihmk	Differentiate the input signal (high->low) register cleared with written mask	SW can read the register, with write mask the register can be cleared
Interrupt low, mask clearing	ilmk	Differentiate the input signal (low->high) register cleared with written mask	SW can read the register, with write mask the register can be cleared
Interrupt enable register	ien	Enables the interrupt source for interrupt generation	SW can read and write this register

Table 10 Register Access Types (cont'd)

Mode	Symbol	Description HW	Description SW
latch_on_reset	lor	rw register, value is latched after first clock cycle after reset	Register is read and writable by SW
Read/write self clearing	rWSC	Register is used as input for the hw, the register will be cleared due to a HW mechanism.	Writing to the register generates a strobe signal for the HW (1 pdi clock cycle) Register is read and writable by SW.

Table 11 Registers Clock DomainsRegisters Clock Domains

Clock Short Name	Description

3.5.1.1 EEPROM Registers Description

Signature Register

ADM6999U/UX will check register 0 value before read all EEPROM content. If this value not match with 0x4154h then other values in EEPROM will be useless. ADM6999U/UX will use internal default value. User can not write Signature register when programming ADM6999U/UX internal register.

SR	Offset	Reset Value
Signature Register	00_H	4154_H

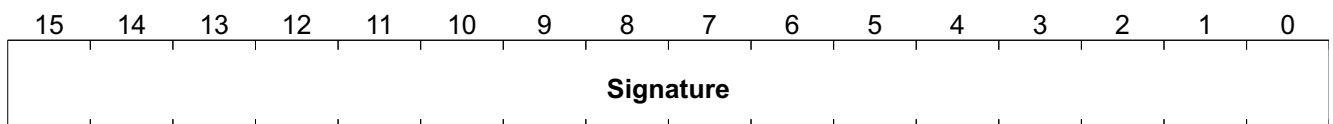

Field	Bits	Type	Description
Signature	15:0	ro	Signature 4154 _H , must be value

Configuration Registers

Register 0x09h bit5 is not effective on disable port. User can disable port by VLAN.

PCR_0 **Offset**
Port Configuration Register 0 **01_H** **Reset Value**
040F_H

15	14	13	12	11	10	9	8	7	6	5	4	3	2	1	0
ANE	SI		ID			PBPN	EN	TOS	PD	TP	DC	SC	AN	FC	

Field	Bits	Type	Description
ANE	15	rw	Auto MDIX Enable Hardware Reset latch value EECK can set global Auto MDIX function. If hardware pin set all port at Auto MDIX then this bit is useless. If hardware pin set chip at non Auto MDIX then this bit can set each port at Auto MDIX. 0 _B D , disable, default 1 _B E , enable
SI	14	rw	Select FX Interface Port7 TX/FX can set by hardware Reset latch value P7FX. If hardware pin set Port7 as FX then this bit is useless. If hardware pin set Port7 as TX then this pin can set Port7 as FX or TX. 0 _B TP , TP mode, default 1 _B FX , FX mode
ID	13:10	rw	Port VLAN ID Check Register 28 _H ~2C _H for other PVID[11:4]. Default 1.
PBPN	9:8	rw	Port Base Priority Number From 1~0 mapping to Q1~Q0. Default 0.
EN	7	rw	Enable Port Based Priority If this bit turn on then ADM6999U/UX will not check TOS or VLAN as priority reference. ADM6999U/UX will check port base priority only. ADM6999U/UX default is bypass mode which checks port base priority only. If users want check VLAN tag priority then must set chip at Tag mode. See 11 _H . 0 _B , Disable, default 1 _B , Enable
TOS	6	rw	TOS Over VLAN Priority Define ADM6999U/UX priority source when VLAN & TOS existed in the packet. 0 _B , VLAN priority level higher than TOS, default 1 _B , TOS priority level higher than VLAN
PD	5	rw	Port Disable Not include Expansion port. Expansion port disable can be done by VLAN separation. 0 _B , enable port, default 1 _B , disable port

Field	Bits	Type	Description
TP	4	rw	VLAN Tag Port 0 _B , Untag port, default 1 _B , Tag port
DC	3	rw	Duplex Capability 0 _B , Half Duplex 1 _B , Full Duplex, default
SC	2	rw	Speed Capability 0 _B , 10M 1 _B , 100M, default
AN	1	rw	Auto Negotiation Capability Enable 0 _B , disable 1 _B , enable, default
FC	0	rw	802.3X Flow Control Capability 0 _B , disable 1 _B , enable, default

Table 12 PCR_x Registers Table

Register Short Name	Register Long Name	Offset Address	Page Number
PCR_1	Port 1 Configuration Register	02 _H	
PCR_2	Port 2 Configuration Register	03 _H	
PCR_3	Port 3 Configuration Register	04 _H	
PCR_4	Port 4 Configuration Register	05 _H	
PCR_5	Port 5 Configuration Register	06 _H	
PCR_6	Port 6 Configuration Register	07 _H	
PCR_7	Port 7 Configuration Register	08 _H	
PCR_8	Port 8 Configuration Register	09 _H	

Note: Register 09_H bit5 is not effective on disable port. User can disable port by VLAN

Gigabit Port Configuration Register

GPCR	Offset	Reset Value
Gigabit Port Configuration Register	0A_H	5902_H

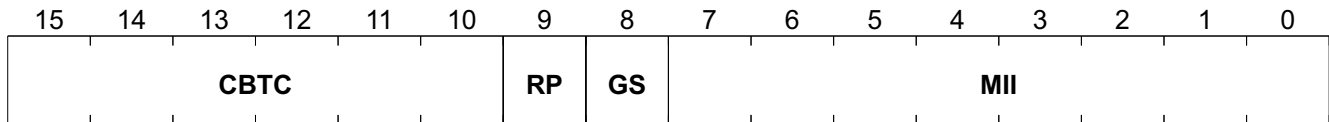

Field	Bits	Type	Description
CBTC	15:10	rw	<p>Cascade Buffer Threshold Control. Casecade buffer threshold control. These bits function only when ADM6999U/UX is configured to the EBUS mode and bit[15] in 27_H is configured to 1. 010110_B , default</p> <p>Bit[13:10]: The buffers allocated to each port in the casecade switch is equal to Bit[13:10] * 4</p> <p>Bit[15:14]: The totally used buffers in the switch.</p> <p>00_B , 48, When the used buffer count reaches 48, the casecade port starts to check the buffer count that has been used by the port in the casecade switch</p> <p>01_B , 64, When the used buffer count reaches 64, the casecade port starts to check the buffer count that has been used by the port in the casecade switch.</p> <p>10_B , 80 When the used buffer count reaches 80, the casecade port starts to check the buffer count that has been used by the port in the casecade switch.</p> <p>11_B , 96 When the used buffer count reaches 96, the casecade port starts to check the buffer count that has been used by the port in the casecade switch.</p>
RP	9	rw	<p>Replaced Packet VID 0, 1 by PVID 1/ADM6999U/UX will replace packet VID by PVID when coming packet's VID=0 or 1, 0/ADM6999U/UX will not replace packet's VID 0 & 1. 0_B , disable, default 1_B , enable</p>
GS	8	rw	<p>Giga Speed selection MSB Gigabit Speed selection MSB bit of MII register 01_H 1_B , default</p>
MII	7:0	rw	<p>MII register 9 bit[15:8] See MII register 09_H definition 20_H , default</p>

Configuration Register

CR	Offset	Reset Value
Configuration Register	0B_H	8000_H

15	14	13	12	11	10	9	8	7	6	5	4	3	2	1	0
FE	Res	Res			Res			ET	EL	Res			Res		

Field	Bits	Type	Description
FE	15	rw	Disable Far_End_Fault Detection ADM6999U/UX will not recognize Far_End_Fault when turn on this bit. 0 _B , enable 1 _B , disable, default
Res	14	ro	Reserved 0 _B , default
Res	13	ro	Reserved 0 _B , default
Res	12:8	ro	Reserved 00000 _B , default
ET	7	rw	Enable Trunk 0 _B , Disable, default 1 _B , enable Port6, 7 as Trunk port
EL	6	rw	Enable IPG Leveling 1/92 bit. 0/96 bit. When this bit is enable ADM6999U/UX will transmit packet out at 96 bit or 92 bit to clean buffer. If user disable this function then ADM6999U/UX will transmit packet at 96 bit. 0 _B , Disable, default 1 _B , Enable
Res	5	ro	Reserved 0 _B , default
Res	4:0	ro	Reserved 00000 _B , default

VLAN Priority Map Register

VLAN_PMR	Offset	Reset Value
VLAN Priority Map Register	0E_H	5500_H

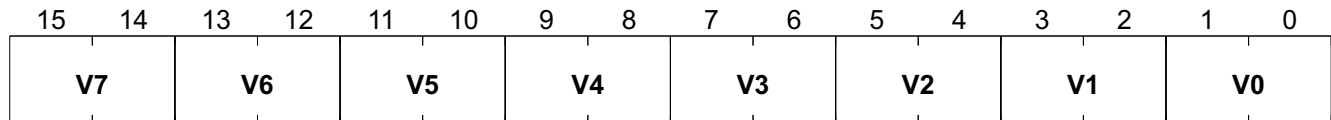

Field	Bits	Type	Description
V7	15:14	rw	Mapped Priority of Tag Value (VLAN) 7 01 _B , default
V6	13:12	rw	Mapped Priority of Tag Value (VLAN) 6 01 _B , default
V5	11:10	rw	Mapped Priority of Tag Value (VLAN) 5 01 _B , default
V4	9:8	rw	Mapped Priority of Tag Value (VLAN) 4 01 _B , default
V3	7:6	rw	Mapped Priority of Tag Value (VLAN) 3 00 _B , default
V2	5:4	rw	Mapped Priority of Tag Value (VLAN) 2 00 _B , default
V1	3:2	rw	Mapped Priority of Tag Value (VLAN) 1 00 _B , default
V0	1:0	rw	Mapped Priority of Tag Value (VLAN) 0 00 _B , default

00: low priority queue. Q0

01: high priority queue. Q1

The weight ratio is 1:N. Queue ratio (defined in 10_H bit[13:12])

Reg. 0x10 Bit[13:12]	Weight Ratio
00	1:1
01	1:2
10	1:3
11	1:4

The default is port-base priority for un-tag packet and none IP frame.

TOS Priority Map Register

TOS_PMR	Offset	Reset Value
TOS Priority Map Register	0F_H	5500_H



Field	Bits	Type	Description
V7	15:14	rw	Mapped Priority of Tag Value (TOS) 7 01 _B , default
V6	13:12	rw	Mapped Priority of Tag Value (TOS) 6 01 _B , default
V5	11:10	rw	Mapped Priority of Tag Value (TOS) 5 01 _B , default
V4	9:8	rw	Mapped Priority of Tag Value (TOS) 4 01 _B , default
V3	7:6	rw	Mapped Priority of Tag Value (TOS) 3 00 _B , default
V2	5:4	rw	Mapped Priority of Tag Value (TOS) 2 00 _B , default
V1	3:2	rw	Mapped Priority of Tag Value (TOS) 1 00 _B , default
V0	1:0	rw	Mapped Priority of Tag Value (TOS) 0 00 _B , default

00: low priority queue. Q0

01: high priority queue. Q1

The weight ratio is 1:N. Queue ratio (defined in 10_H/bit[13:12])

Reg. 0x10 Bit[13:12]	Weight Ratio
00	1:1
01	1:2
10	1:3
11	1:4

The default is port-base priority for un-tag packet and none IP frame.

Packet with Priority

- Normal Packet Content

Ethernet Packet from Layer 2

Preamble/SFD	Destination (6 bytes)	Source (6 bytes)	Packet length (2 bytes)	Data (46-1500 bytes)	CRC (4 bytes)
–	Byte 0~5	Byte 6~11	Byte 12~13	Byte 14	–

- **VLAN Packet**

ADM6999U/UX will check packet byte 12 &13. If byte[12:13] = 8100h then this packet is a VLAN packet.

Tag Protocol TD 8100	Tag Control Information TCI	LEN Length	Routing Information
Byte 12~13	Byte14~15	Byte 16~17	Byte 18

Byte 14~15: Tag Control Information TCI

Bit[15:13]: User Priority 7~0

Bit 12: Canonical Format Indicator (CFI)

Bit[11~0]: VLAN ID. The ADM6999U/UX will use bit[3:0] as VLAN group.

- **TOS IP Packet**

ADM6999U/UX check byte 12 &13 if this value is 0800h then ADM6999U/UX knows this is a TOS priority packet.

Type 0800	IP Header
Byte 12~13	Byte 14~15

IP header define
Byte 14

Bit[7:0]: IP protocol version number & header length

Byte 15: Service type

Bit[7~5]: IP Priority (Precedence) from 7~0

Bit 4: No Delay (D)

Bit 3: High Throughput

Bit 2: High Reliability (R)

Bit[1:0]: Reserved

Miscellaneous Configuration Register 0

MCR_0	Offset	Reset Value
Miscellaneous Configuration Register 0	10_H	0040_H

15	14	13	12	11	10	9	8	7	6	5	4	3	2	1	0
Res	QR	DM1	DM0	AD	Res	Res	XCRC	Res	BSE	BST					

Field	Bits	Type	Description
Res	15:14	ro	Reserved
QR	13:12	rw	Queue Ratio 00 _B , 1:1 01 _B , 1:2 10 _B , 1:3 11 _B , 1:4
DM1	11:10	rw	Discard Mode (drop scheme for Q1)
DM0	9:8	rw	Discard Mode (drop scheme for Q0)
AD	7	rw	Aging Disable 0 _B , enable aging, default 1 _B , disable aging
Res	6	ro	Reserved 0 _B , default
Res	5	ro	Reserved 0 _B , default
XCRC	4	rw	CRC Check Disable 0 _B , enable CRC Check, default 1 _B , disable CRC check
Res	3	ro	Reserved 0 _B , default
BSE	2	rw	Broadcast Storming Enable 0 _B , disable, default 1 _B , enable
BST	1:0	rw	Broadcast Storming Threshold See below table. 00 _B , default

Broadcast storm mode after initial:

Time interval : 50 ms

The max. packet number = 7490 in 100Base, 749 in 10Base

Table 13 Per Port Rising Threshold

	00	01	10	11
All 100TX	Disable	10%	20%	40%
Not All 100TX	Disable	1%	2%	4%

Table 14 Per Port Falling Threshold

	00	01	10	11
All 100TX	Disable	5%	10%	20%
Not All 100TX	Disable	0.5%	1%	2%

Table 15 Drop Scheme for each Queue

Discard Mode/ Utilization	00	01	10	11
TBD	0%	0%	25%	50%

VLAN Mode Select Register

VLAN_MSR	Offset	Reset Value
VLAN Mode Select Register	11_H	FF00_H

15	14	13	12	11	10	9	8	7	6	5	4	3	2	1	0
		Res			BP	T	Res	Res		MS	CE			Res	

Field	Bits	Type	Description
Res	15:11	ro	Reserved 11111 _B , default
BP	10	rw	Back-pressure Enable This is a global pin for all ports. 0 _B , disable 1 _B , enable, default
T	9	rw	RMII TXEN Timing If user connect several ADM6999U/UX to be Hubbing Switch then this bit turn on. If user connect RMII to RMII PHY then this bit must turn off. RMII mode supports half duplex only. 0 _B , RMII PHY 1 _B , Hubbing Switch, default
Res	8	ro	Reserved 1 _B , default
Res	7:6	ro	Reserved 00 _B , default
MS	5	rw	VLAN Mode Select 0 _B , by-pass mode with port-base VLAN, default 1 _B , 802.1Q base VLAN
CE	4	rw	MAC Clone Enable 0 _B , Normal mode. Learning with SA only. ADM6999U/UX fill/search MAC table by SA or DA only. Default. 1 _B , MAC Clone mode. Learning with SA, VID0. ADM6999U/UX fill/search MAC table by SA or DA with VID0. This bit can let chip learn two same addresses with different VID0.
Res	3:0	ro	Reserved 0000 _B , default

Below is Bit4, 5 VLAN Tag and MAC application example base on Infineon-ADMtek Co Ltd ADM6996.

Table 16 ADM6996 Port Mapping with ADM6999U/UX

ADM6996	ADM6999U/UX
Port0	Port0
–	Port1
Port1	Port2
–	Port3
Port2	Port4
–	Port5
Port3	Port6
Port4	Port7
Port5 MII	Port8 MII

Below is Router old architecture. The disadvantages of this are:

1. WAN port only support 10M Half-Duplex and non-MDIX function.
2. Need extra 10M NIC cost.
3. ISA bus will become bottleneck of whole system.

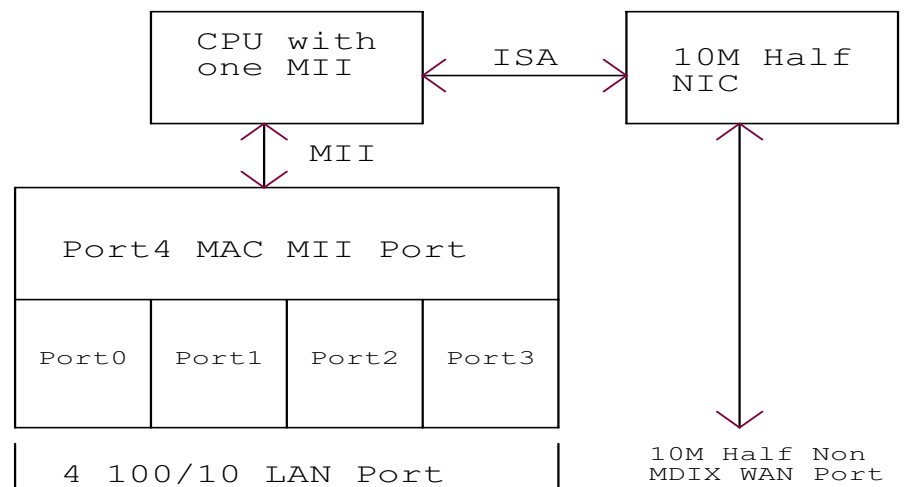

Figure 6 Router old architecture

Below is new architecture by using ADM6999U/UX serial chip VLAN function. The advantages of below are:

1. WAN Port can upgrade to 100/10 Full/Half, Auto MDIX.
2. WAN/LAN Port is programmable and put on same Switch.
3. No extra NIC and save the cost.
4. High bandwidth of MII port up to 200M speed.

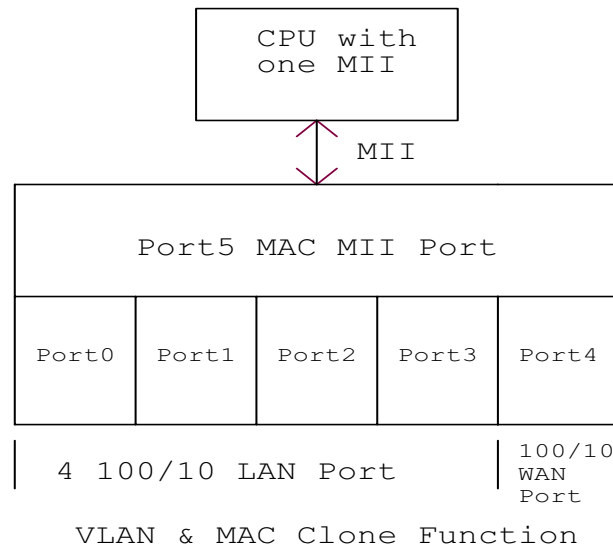

Figure 7 New architecture by using ADM6999U/UX serial chip VLAN function

New Router application works well on normal application. If user's ISP vendor (cable modem) lock Registration Card's ID then Router CPU must send this Lock Registration Card's ID to WAN Port. One condition happen is there exist two same MAC ID on this Switch. One is original Card and another one is CPU. This will make Switch learning table trouble.

ADM6999U/UX provides MAC Clone function that allows two same MAC addresses with different VLAN ID0 on learning table. This will solve Lock registration Card's ID issue. ADM6999U/UX serial chip will put these two same MAC addresses with different VLAN ID0 at different learning table entry.

How to Set ADM6999U/UX on Router:

- Port0~3: LAN Port
- Port4: WAN Port
- Port5: MII Port as CPU Port

Step1: Set Register 11_H bit4 and bit5 to 1.

{Coding: Write Register 11_H as 0xff30h}

Step2: Set Port0~3 as Untag Port and set PVID = 1.

{Coding: Write Register 01_H, 03_H, 05_H, 07_H as 840F_H. Port0~3 as Untag, PVID = 1, Enable MDIX}

Step3: Set Port4 as Untag Port and set PVID = 2.

{Coding: Write Register 08_H as 880F_H. Port4 as Untag, PVID = 2, Enable MDIX.}

Step4: Set Port5 MII Port as Tag Port and set PVID = 2.

{Coding: Write Register 09_H as 881F_H. Port5 MII port as Tag, PVID = 2.}

Step5: Group Port0, 1, 2, 3, 5 as VLAN 1.

{Coding: Write Register 14_H as 0155_H. VLAN1 cover Port0, 1, 2, 3, 5.}

Step6: Group Port4, 5 as VLAN 2.

{Coding: Write Register 15_H as 0180_H. VLAN2 cover Port4, 5.}

How MAC Clone Operation:

1. LAN to LAN/CPU Traffic. ADM6999U/UX LAN traffic to LAN/CPU only. Traffic to another LAN port will be untag packet. Traffic to CPU is Tag packet with VID = 1. CPU can check VID to distinguish LAN traffic or WAN traffic.

Descriptions

2. WAN to CPU Traffic. ADM6999U/UX WAN traffic to CPU only. Traffic to CPU is Tag packet with VID = 2. CPU can check VID to distinguish LAN traffic or WAN traffic.
3. CPU to LAN Packet. ADM6999U/UX CPU Packet to LAN port must add VID = 1 in VLAN field. ADM6999U/UX check VID to distinguish LAN traffic or WAN traffic. LAN output packet is Untag.
4. CPU to WAN Packet. ADM6999U/UX CPU Packet to WAN port must add VID = 2 in VLAN field. ADM6999U/UX check VID to distinguish LAN traffic or WAN traffic. WAN output packet is Untag.
5. ADM6999U/UX learning sequence. ADM6999U/UX will check VLAN mapping setting first then check learning table. User does not worry LAN/WAN traffic mix up.

Note: Bit 10: Half Duplex Back Pressure enable. 1/enable, 0/disable.

Miscellaneous Configuration Register 2

MCR_2	Offset	Reset Value
Miscellaneous Configuration Register 2	12_H	3600_H

15	14	13	12	11	10	9	8	7	6	5	4	3	2	1	0
DP	Res	PS	Res	Res	Res	EPML	ML7	ML6	ML5	ML4	ML3	ML2	ML1	ML0	

Field	Bits	Type	Description
DP	15	rw	Drop Packet when Excessive Collision Happen Enable 0 _B , Disable, default 1 _B , enable
Res	14	ro	Reserved
PS	13:12	rw	Power Saving Select
Res	11	ro	Reserved
Res	10:9	ro	Reserved
EPML	8	rw	Expansion Port MAC Lock 0 _B , Disable, default 1 _B , Lock first MAC source address
ML7	7	rw	Port7 MAC Lock 0 _B , Disable, default 1 _B , Lock first MAC source address
ML6	6	rw	Port6 MAC Lock 0 _B , Disable, default 1 _B , Lock first MAC source address
ML5	5	rw	Port5 MAC Lock 0 _B , Disable, default 1 _B , Lock first MAC source address
ML4	4	rw	Port4 MAC Lock 0 _B , Disable, default 1 _B , Lock first MAC source address

Descriptions

Field	Bits	Type	Description
ML3	3	rw	Port3 MAC Lock 0 _B , Disable, default 1 _B , Lock first MAC source address
ML2	2	rw	Port2 MAC Lock 0 _B , Disable, default 1 _B , Lock first MAC source address
ML1	1	rw	Port1 MAC Lock 0 _B , Disable, default 1 _B , Lock first MAC source address
ML0	0	rw	Port0 MAC Lock 0 _B , Disable, default 1 _B , Lock first MAC source address

Notes

1. Bit [8:0]: Port Locking enable. Learn one MAC ID when enable. 1/enable. 0/disable.
2. Bit[15]: Half Duplex excessive collision (16) drop packet enable. 1/drop. 0/no drop.

VLAN Mapping Table Register 0

16 VLAN Group: See Register 2C_H bit 11_B = 0

VLAN_MTR_0	Offset	Reset Value
VLAN Mapping Table Register 0	13 _H	FFFF _H

15	14	13	12	11	10	9	8	7	6	5	4	3	2	1	0
Res							P8	P7	P6	P5	P4	P3	P2	P1	P0

Field	Bits	Type	Description
P8	8	rw	VLAN Mapping Table Expansion Port
P7	7	rw	VLAN Mapping Table Port7
P6	6	rw	VLAN Mapping Table Port6
P5	5	rw	VLAN Mapping Table Port5
P4	4	rw	VLAN Mapping Table Port4
P3	3	rw	VLAN Mapping Table Port3
P2	2	rw	VLAN Mapping Table Port2

Field	Bits	Type	Description
P1	1	rw	VLAN Mapping Table Port1
P0	0	rw	VLAN Mapping Table Port0

Select the VLAN group ports is to set the corresponding bits to 1.

VLAN Mapping Table Registers 0

32 VLAN Group: See Register 2C_H bit 11_B = 1

VLAN_MTR																Offset	Reset Value
VLAN Mapping Table Registers																13 _H	FFFF _H
15	14	13	12	11	10	9	8	7	6	5	4	3	2	1	0		
P7	P6	P5	P4	P3	P2	P1	P0	P7	P6	P5	P4	P3	P2	P1	P0		

Field	Bits	Type	Description
P7	15	rw	Port 7, Odd VLAN Mapping Table
P6	14	rw	Port 6, Even VLAN Mapping Table
P5	13	rw	Port 5, Odd VLAN Mapping Table
P4	12	rw	Port 4, Even VLAN Mapping Table
P3	11	rw	Port 3, Odd VLAN Mapping Table
P2	10	rw	Port 2, Even VLAN Mapping Table
P1	9	rw	Port 1, Odd VLAN Mapping Table
P0	8	rw	Port 0, Even VLAN Mapping Table
P7	7	rw	Port 7, Odd VLAN Mapping Table
P6	6	rw	Port 6, Even VLAN Mapping Table
P5	5	rw	Port 5, Odd VLAN Mapping Table
P4	4	rw	Port 4, Even VLAN Mapping Table
P3	3	rw	Port 3, Odd VLAN Mapping Table
P2	2	rw	Port 2, Even VLAN Mapping Table
P1	1	rw	Port 1, Odd VLAN Mapping Table
P0	0	rw	Port 0, Even VLAN Mapping Table

All VLAN groups will cover Port8 at 32 group mode. This feature is good for multiple ADM6999U/UX systems.

Table 17 VLAN_MTR_x Registers Table

Register Short Name	Register Long Name	Offset Address	Page Number
VLAN_MTR_1	VLAN Mapping Table Register 1	14 _H	
VLAN_MTR_2	VLAN Mapping Table Register 2	15 _H	
VLAN_MTR_3	VLAN Mapping Table Register 3	16 _H	
VLAN_MTR_4	VLAN Mapping Table Register 4	17 _H	
VLAN_MTR_5	VLAN Mapping Table Register 5	18 _H	
VLAN_MTR_6	VLAN Mapping Table Register 6	19 _H	
VLAN_MTR_7	VLAN Mapping Table Register 7	1A _H	
VLAN_MTR_8	VLAN Mapping Table Register 8	1B _H	
VLAN_MTR_9	VLAN Mapping Table Register 9	1C _H	
VLAN_MTR_10	VLAN Mapping Table Register 10	1D _H	
VLAN_MTR_11	VLAN Mapping Table Register 11	1E _H	
VLAN_MTR_12	VLAN Mapping Table Register 12	1F _H	
VLAN_MTR_13	VLAN Mapping Table Register 13	20 _H	
VLAN_MTR_14	VLAN Mapping Table Register 14	21 _H	
VLAN_MTR_15	VLAN Mapping Table Register 15	22 _H	

Port Buffer Threshold Control Registers P0, P1

PBTCR_P01	Offset	Reset Value
Port Buffer Threshold Control Reg. P0, P1	23_H	0000_H

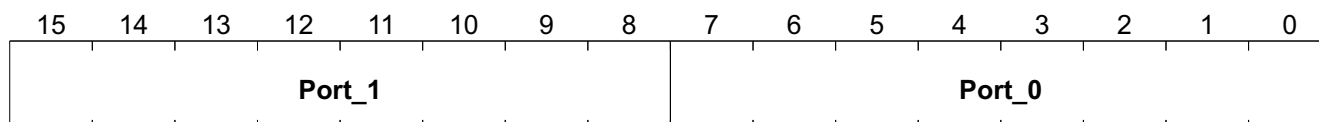

Field	Bits	Type	Description
Port_1	15:8	rw	Port1, Odd Port Buffer Threshold Control
Port_0	7:0	rw	Port0, Even Port Buffer Threshold Control

Port Buffer Threshold Control Register P2, P3

PBTCR_P23	Offset	Reset Value
Port Buffer Threshold Control Reg. P2, P3	24_H	0000_H

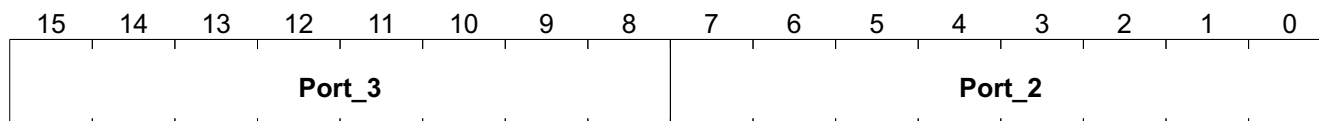

Field	Bits	Type	Description
Port_3	15:8	rw	Port3, Odd Port Buffer Threshold Control
Port_2	7:0	rw	Port2, Even Port Buffer Threshold Control

Port Buffer Threshold Control Register P4, P5

PBTCR_P45	Offset	Reset Value
Port Buffer Threshold Control Reg. P4, P5	25_H	0000_H

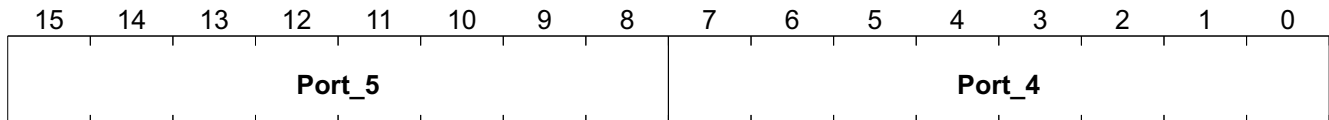

Field	Bits	Type	Description
Port_5	15:8	rw	Port5, Odd Port Buffer Threshold Control
Port_4	7:0	rw	Port4, Even Port Buffer Threshold Control

Port Buffer Threshold Control Register P6, P7

PBTCR_P67	Offset	Reset Value
Port Buffer Threshold Control Reg. P6, P7	26_H	0000_H

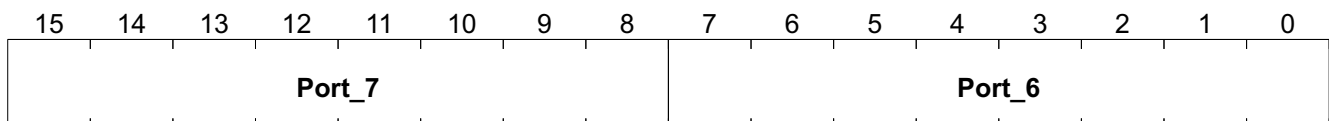

Field	Bits	Type	Description
Port_7	15:8	rw	Port7, Odd Port Buffer Threshold Control
Port_6	7:0	rw	Port6, Even Port Buffer Threshold Control

ADM6999U/UX supports buffer management scheme with dynamic thresholds to ensure the fair share of memory among different port queues. If users need each port to have a fixed threshold, they can configure the Bit 14 in the 27_H to 1.

Dynamic threshold management:

Bit[7]: The add bit. Bit[6:0]: The offset bits.

When Bit[7] = 1, the switch will use the value (buffers really used + 2*bit[6:0]) as the buffer count that the port has used.

When Bit[7] = 0, the switch will use the value (buffers really used - 2*bit[6:0]) as the buffer count that the port has used.

Fixed threshold management:

Bit[3:0]: The buffer threshold bits.

When the total buffer was not reached, the buffer amount allocated to each port will be equal to bit[3:0] * 4.

Port4, 5 PVID bit 11~4 Configuration Register

PVID11_4_CR_P45	Offset	Reset Value
Port4, 5 PVID bit 11~4 Configuration Register	2A_H	0000_H

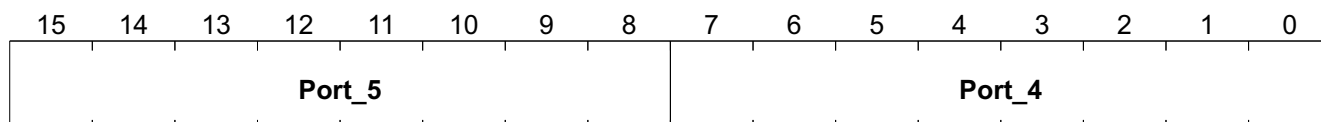

Field	Bits	Type	Description
Port_5	15:8	rw	Port5 PVID bit 11~4 These 8 bits combine with register 06 _H Bit[13~10] as full 12 bit VID. 00 _H , default
Port_4	7:0	rw	Port4 PVID bit 11~4 These 8 bits combine with register 05 _H Bit[13~10] as full 12 bit VID. 00 _H , default

Port6, 7 PVID bit 11~4 Configuration Register

PVID11_4_CR_P67	Offset	Reset Value
Port6, 7 PVID bit 11~4 Configuration Register	2B_H	0000_H

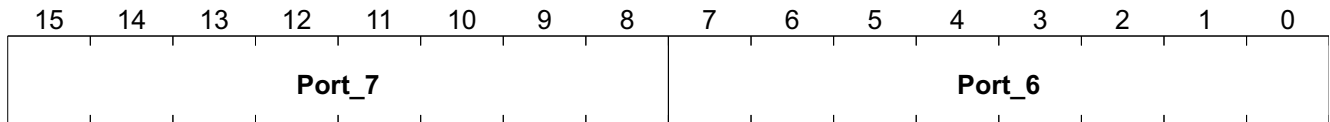

Field	Bits	Type	Description
Port_7	15:8	rw	Port7 PVID bit 11~4 These 8 bits combine with register 08 _H Bit[13~10] as full 12 bit VID. 00 _H , default
Port_6	7:0	rw	Port6 PVID bit 11~4 These 8 bits combine with register 07 _H Bit[13~10] as full 12 bit VID. 00 _H , default

Port8 PVID bit 11~4 and VLAN Group Shift Bits Configuration Register

PVID11_4_VLAN_CR	Offset	Reset Value
P8 PVID bit 11~4/VLAN Group Shift Bits Conf.	2C_H	D000_H

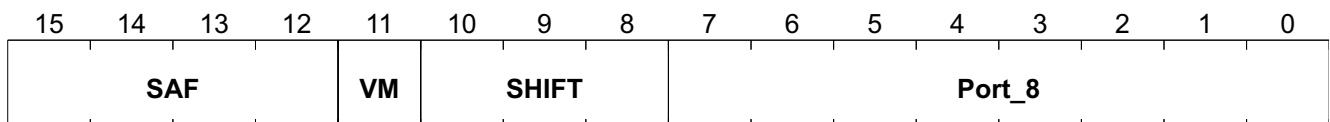

Field	Bits	Type	Description
SAF	15:12	rw	<p>Special Address Forwarding IEEE 802.3 reserved DA forward or drop police 1101_H , default</p> <p>Bit[15] Control reserved MAC (0180C2000010-0180C20000FF) 0_B , Discard 1_B , Forward, default</p> <p>Bit[14] Control reserved MAC (0180C2000002- 0180C200000F) 0_B , Discard 1_B , Forward, default</p> <p>Bit[13] Control reserved MAC (0180C2000001) 0_B , Discard, default 1_B , Forward</p> <p>Bit[12] Control reserved MAC (0180C2000000) 0_B , Discard 1_B , Forward, default</p>
VM	11	rw	<p>VLAN Mode Select 16 or 32 VLAN group. 0_B , 16 VLAN group,default 1_B , 32 VLAN group,default</p>
SHIFT	10:8	rw	<p>Tag Shift for VLAN Grouping VLAN Tagshift register. ADM6999U/UX will select 4/5 bit from total 12 bit VID as VLAN group preference. Select 4 or 5 bit from VID depend on bit 11 setting. For example Bit[10:8] = 001, Bit11 = 0, then ADM6999U/UX will select packet VID4~VID1 as VLAN group mapping. It is very flexible for user on VLAN grouping. 00C_H , default</p> <p>16 VLAN Mode 0_D , VID[3:0] 1_D , VID[4:1] 2_D , VID[5:2] 3_D , VID[6:3] 4_D , VID[7:4] 5_D , VID[8:5] 6_D , VID[9:6] 7_D , VID[10:7]</p> <p>32 VLAN Mode 0_D , VID[4:0] 1_D , VID[5:1] 2_D , VID[6:2] 3_D , VID[7:3] 4_D , VID[8:4] 5_D , VID[9:5] 6_D , VID[10:6] 7_D , VID[11:7]</p>

Descriptions

Field	Bits	Type	Description
Port_8	7:0	rw	Expansion Port PVID bit 11~4 These 8 bits combine with register 09 _H Bit[13~10] as full 12 bit VID. 00 _H , default

3.6 EEPROM Access Description

Customer can select ADM6999U/UX read EEPROM contents as chip setting or not. ADM6999U/UX will check the signature of EEPROM to decide read content of EEPROM or not.

Table 18 RC & EEPROM Content Relationship

RC	CS	SK	DI	DO
0	High Impedance	High Impedance	High Impedance	High Impedance
Rising edge 01 (30ms)	Output	Output	Output	Input
1 (after 30 ms)	Input	Input	I/O	Input

Keep at least 30 ms after RC from 0 to 1. ADM6999U/UX will read data from EEPROM. After RC if CPU update EEPROM that ADM6999U/UX will update configuration registers too.

When CPU programs EEPROM & ADM6999U/UX, ADM6999U/UX recognizes the EEPROM WRITE instruction only. If there is any Protection instruction before or after the EEPROM WRITE instruction, CPU needs to generate separated CS signal cycle for each Protection & WRITE instruction.

CPU can directly program ADM6999U/UX after 30ms of Reset signal rising edge with or without EEPROM.

ADM6999U/UX serial chips will latch hardware-reset value as recommend value. It includes EEPROM interface:

- EECS: Internal Pull down 40K resistor.
- EESK: TP port Auto-MDIX select. Internal pull down 40K resistor as non Auto-MDIX mode.
- EDI: Dual Color Select. Internal pull down 40K resistor as Single Color Mode.
- EDO: EEPROM enable. Internal pull up 40K resistor as EEPROM enable.

Below Figure is ADM6999U/UX serial chips EEPROM pins operation at different stage. Reset signal is control by CPU with at least 100ms low. Point1 is Reset rising edge. CPU must prepare proper value on ECS(0), EESK, EDI, EDO(1) before this rising edge. ADM6999U/UX will read this value into chip at Point2. CPU must keep these values over point2. Point2 is 200ns after Reset rising edge.

ADM6999U/UX serial chips will read EEPROM content at Point4 which 800ns far away from the rising edge of Reset. CPU must turn EEPROM pins EECS, EESK, EDI and EDO to High-Z or pull high before Point4.

If users want change the state to High-Z or pull high on EEPROM pins, the order is CS-> DI -> DO -> SK is better.

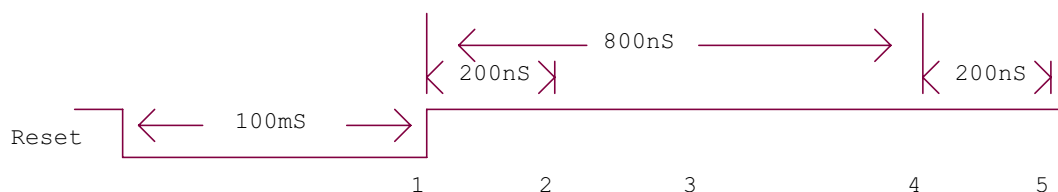

Figure 8 ADM6999U/UX serial chips EEPROM pins operation

The timing for writing to EEPROM is a little bit different. See below graph. Must be carefully when CS goes down after writing a command, SK must issue at least one clock. This is a difference between ADM6999U/UX with EEPROM write timing. If system is without EEPROM then users must write ADM6999U/UX internal register by 93C66 timing. If users use EEPROM then the writing timing is depend on EEPROM type.

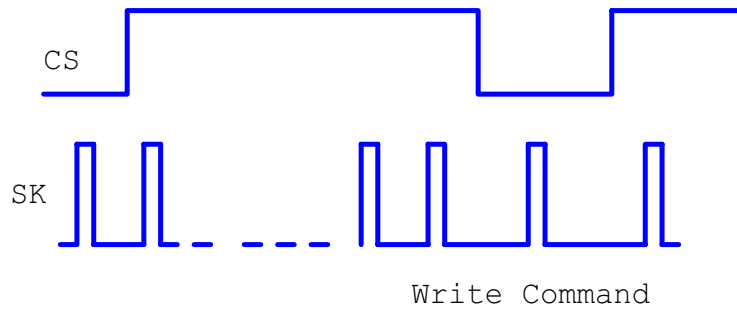

Figure 9 EEPROM Writing Command

4 TX/FX Interface

4.1 TP Interface

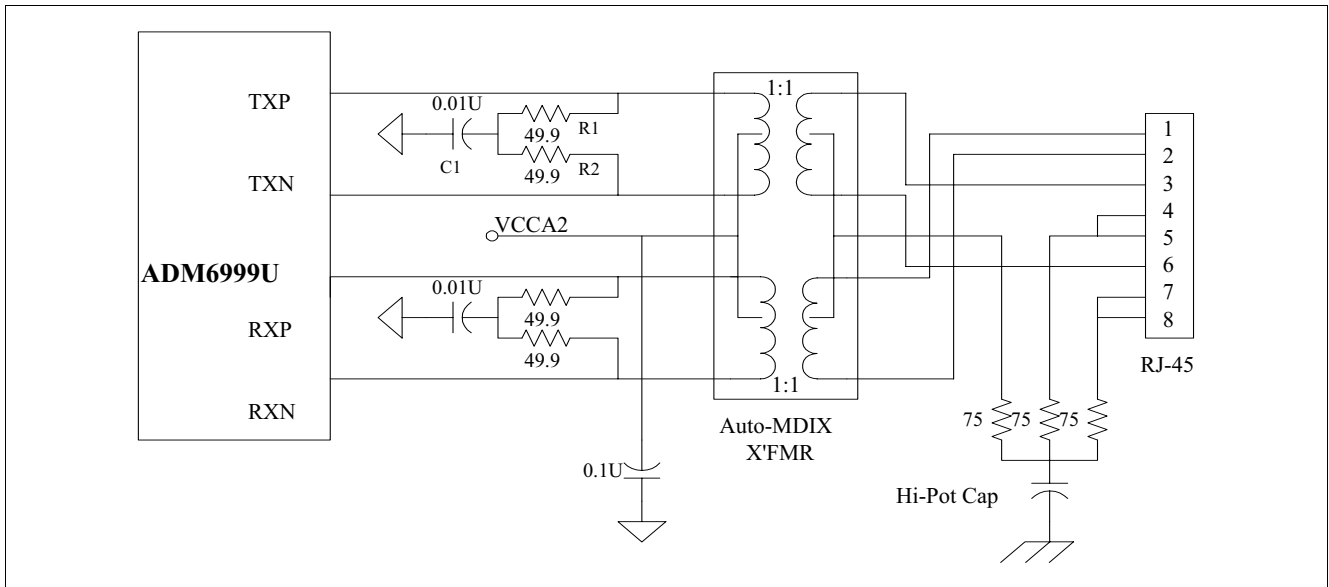

Figure 10 TP Interface

Transformer requirement:

- TX/RX rate 1:1
- TX/RX central tap connect together to VCCA2.

Users can change TX/RX pin for easy layout but do not change polarity. ADM6999U/UX supports auto polarity on receiving side.

4.2 FX Interface

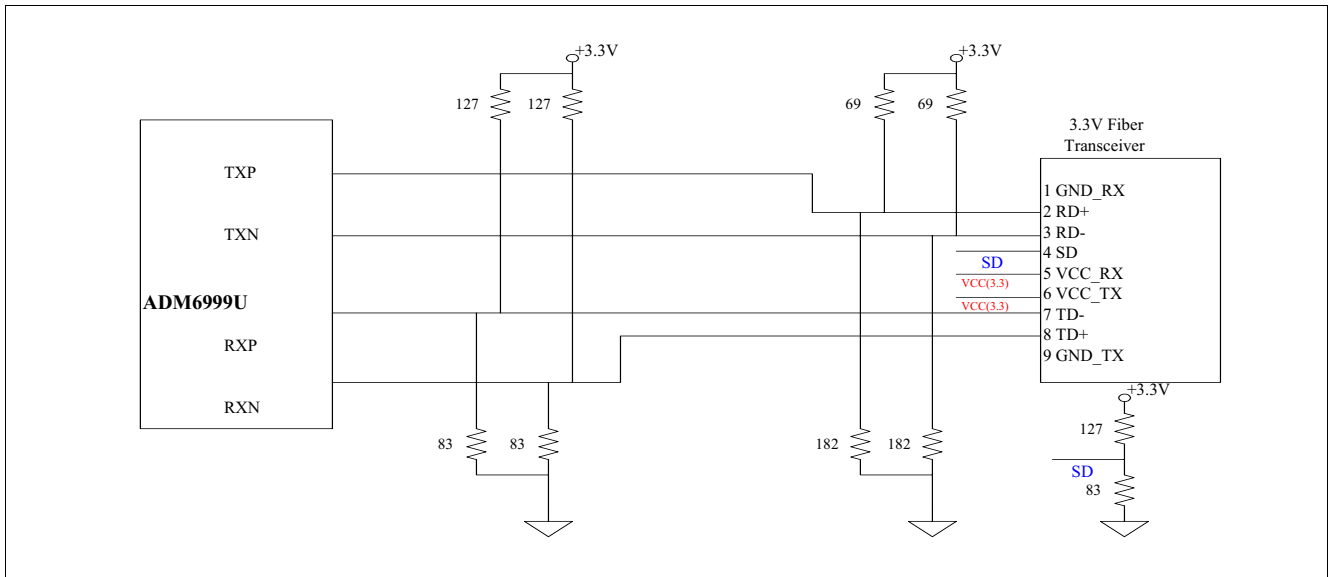

Figure 11 FX Interface

5 DC Characteristics

Table 19 Absolute Maximum Ratings

Parameter	Symbol	Values			Unit	Note / Test Condition
		Min.	Typ.	Max.		
Power Supply	V_{CC}	-0.3	–	3.63	V	–
TX line driver	V_{cca2}	–	–	1.8	V	–
PLL voltage	V_{ccpll}	–	–	1.8	V	–
Digital core voltage	V_{ccik}	–	–	1.8	V	–
Input Voltage	V_{IN}	-0.3	–	$V_{CC} + 0.3$	V	–
Output Voltage	V_{out}	-0.3	–	$V_{CC} + 0.3$	V	–
Storage Temperature	T_{STG}	-55	–	155	°C	–
Power Dissipation	PD	–	–	1.8	W	–
ESD Rating	ESD	–	–	2	KV	–

Table 20 Recommended Operating Conditions

Parameter	Symbol	Values			Unit	Note / Test Condition
		Min.	Typ.	Max.		
Power Supply	V_{CC}	2.8	3.3	3.465	V	–
TX line driver	V_{cca2}	1.7	1.8	1.9	V	–
PLL voltage	V_{ccpll}	1.7	1.8	1.9	V	–
Digital core voltage	V_{ccik}	1.7	1.8	1.9	V	–
Input Voltage	V_{in}	0	–	V_{CC}	V	–
Power consumption	PC	–	1.8	–	W	–
Junction Operating Temperature	T_j	0	25	115	°C	–

Table 21 DC Electrical Characteristics for 3.3 V Operation¹⁾

Parameter	Symbol	Values			Unit	Note / Test Condition
		Min.	Typ.	Max.		
Input Low Voltage	V_{IL}	–	–	$0.3 * V_{CC}$	V	CMOS
Input High Voltage	V_{IH}	$0.7 * V_{CC}$	–	–	V	CMOS
Output Low Voltage	V_{OL}	–	–	0.4	V	CMOS
Output High Voltage	V_{OH}	$0.7 * V_{CC}$	–	–	V	CMOS
Input Pull-up/down Resistance	R_I	–	100	–	kΩ	$V_{IL} = 0 \text{ V}$ or $V_{IH} = V_{CC}$

1) (under $V_{CC} = 3.0 \text{ V} \sim 3.6 \text{ V}$, $T_j = 0 \text{ °C} \sim 115 \text{ °C}$)

6 Serial Management

6.1 Serial Registers Map

Table 22 Registers Address Space

Module	Base Address	End Address	Note
Serial	00 _H	3C _H	

Table 23 Registers Overview

Register Short Name	Register Long Name	Offset Address	Page Number
Chip_ID	Chip Identifier Register	00 _H	66
PSR_0	Port Status 0 Register	01 _H	67
PSR_1	Port Status 1 Register	02 _H	70
CBSR	Cable Broken Status Register	03 _H	71
RPC_0	Port 0 Receive Packet Count	04 _H	71
RPC_1	Port 1 Receive Packet Count	05 _H	72
RPBC_2	Port 2 Receive Packet Byte Count	05 _H	72
RPC_2	Port 2 Receive Packet Count	06 _H	72
RPC_3	Port 3 Receive Packet Count	07 _H	72
RPC_4	Port 4 Receive Packet Count	08 _H	72
RPC_5	Port 5 Receive Packet Count	09 _H	72
RPC_6	Port 6 Receive Packet Count	0A _H	72
RPC_7	Port 7 Receive Packet Count	0B _H	72
RPC_8	Port 8 Receive Packet Count	0C _H	72
RPBC_0	Port 0 Receive Packet Byte Count	0E _H	72
RPBC_1	Port 1 Receive Packet Byte Count	0F _H	72
RPBC_3	Port 3 Receive Packet Byte Count	10 _H	72
RPBC_4	Port 4 Receive Packet Byte Count	11 _H	72
RPBC_5	Port 5 Receive Packet Byte Count	12 _H	72
RPBC_6	Port 6 Receive Packet Byte Count	13 _H	72
RPBC_7	Port 7 Receive Packet Byte Count	14 _H	72
RPBC_8	Port 8 Receive Packet Byte Count	15 _H	72
TPC_0	Port 0 Transmit Packet Count	16 _H	72
TPC_1	Port 1 Transmit Packet Count	17 _H	72
TPC_2	Port 2 Transmit Packet Count	18 _H	72
TPC_3	Port 3 Transmit Packet Count	19 _H	72
TPC_4	Port 4 Transmit Packet Count	1A _H	72
TPC_5	Port 5 Transmit Packet Count	1B _H	72
TPC_6	Port 6 Transmit Packet Count	1C _H	72
TPC_7	Port 7 Transmit Packet Count	1D _H	72

Table 23 Registers Overview (cont'd)

Register Short Name	Register Long Name	Offset Address	Page Number
TPC_8	Port 8 Transmit Packet Count	1E _H	72
TPBC_0	Port 0 Transmit Packet Byte Count	1F _H	72
TPBC_1	Port 1 Transmit Packet Byte Count	20 _H	72
TPBC_2	Port 2 Transmit Packet Byte Count	21 _H	72
TPBC_3	Port 3 Transmit Packet Byte Count	22 _H	72
TPBC_4	Port 4 Transmit Packet Byte Count	23 _H	72
TPBC_5	Port 5 Transmit Packet Byte Count	24 _H	72
TPBC_6	Port 6 Transmit Packet Byte Count	25 _H	72
TPBC_7	Port 7 Transmit Packet Byte Count	26 _H	72
TPBC_8	Port 8 Transmit Packet Byte Count	27 _H	73
CC_0	Port 0 Collision Count	28 _H	73
CC_1	Port 1 Collision Count	29 _H	73
CC_2	Port 2 Collision Count	2A _H	73
CC_3	Port 3 Collision Count	2B _H	73
CC_4	Port 4 Collision Count	2C _H	73
CC_5	Port 5 Collision Count	2D _H	73
CC_6	Port 6 Collision Count	2E _H	73
CC_7	Port 7 Collision Count	2F _H	73
CC_8	Port 8 Collision Count	30 _H	73
EC_0	Port 0 Error Count	31 _H	73
EC_1	Port 1 Error Count	32 _H	73
EC_2	Port 2 Error Count	33 _H	73
EC_3	Port 3 Error Count	34 _H	73
EC_4	Port 4 Error Count	35 _H	73
EC_5	Port 5 Error Count	36 _H	73
EC_6	Port 6 Error Count	37 _H	73
EC_7	Port 7 Error Count	38 _H	73
EC_8	Port 8 Error Count	39 _H	73
OFFR_0	Over Flow Flag 0 Register	3A _H	74
OFFR_1	Over Flow Flag 1 Register	3B _H	75
OFFR_2	Over Flow Flag 2 Register	3C _H	76

The register is addressed wordwise.

Table 24 Register Access Types

Mode	Symbol	Description HW	Description SW
read/write	rw	Register is used as input for the HW	Register is read and writable by SW
read	r	Register is written by HW (register between input and output -> one cycle delay)	Value written by software is ignored by hardware; that is, software may write any value to this field without affecting hardware behavior (= Target for development.)

Table 24 Register Access Types (cont'd)

Mode	Symbol	Description HW	Description SW
Read only	ro	Register is set by HW (register between input and output -> one cycle delay)	SW can only read this register
Read virtual	rv	Physically, there is no new register, the input of the signal is connected directly to the address multiplexer.	SW can only read this register
Latch high, self clearing	lhsc	Latch high signal at high level, clear on read	SW can read the register
Latch low, self clearing	llsc	Latch high signal at low-level, clear on read	SW can read the register
Latch high, mask clearing	lhmk	Latch high signal at high level, register cleared with written mask	SW can read the register, with write mask the register can be cleared (1 clears)
Latch low, mask clearing	llmk	Latch high signal at low-level, register cleared on read	SW can read the register, with write mask the register can be cleared (1 clears)
Interrupt high, self clearing	ihsc	Differentiate the input signal (low->high) register cleared on read	SW can read the register
Interrupt low, self clearing	ilsc	Differentiate the input signal (high->low) register cleared on read	SW can read the register
Interrupt high, mask clearing	ihmk	Differentiate the input signal (high->low) register cleared with written mask	SW can read the register, with write mask the register can be cleared
Interrupt low, mask clearing	ilmk	Differentiate the input signal (low->high) register cleared with written mask	SW can read the register, with write mask the register can be cleared
Interrupt enable register	ien	Enables the interrupt source for interrupt generation	SW can read and write this register
latch_on_reset	lor	rw register, value is latched after first clock cycle after reset	Register is read and writable by SW
Read/write self clearing	rwsc	Register is used as input for the hw, the register will be cleared due to a HW mechanism.	Writing to the register generates a strobe signal for the HW (1 pdi clock cycle) Register is read and writable by SW.

Table 25 Registers Clock DomainsRegisters Clock Domains

Clock Short Name	Description

6.1.1 Serial Registers Description

Chip Identifier Register

Chip_ID	Offset	Reset Value
Chip Identifier Register	00 _H	0002 1120 _H

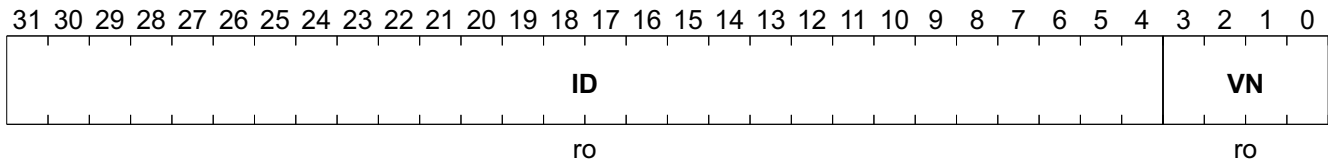

Field	Bits	Type	Description
ID	31:4	ro	ID 0002112 _H ID,
VN	3:0	ro	Version number 0000 _B VN,

Port Status 0 Register

PSR_0	Offset	Reset Value
Port Status 0 Register	01_H	0000 0000_H

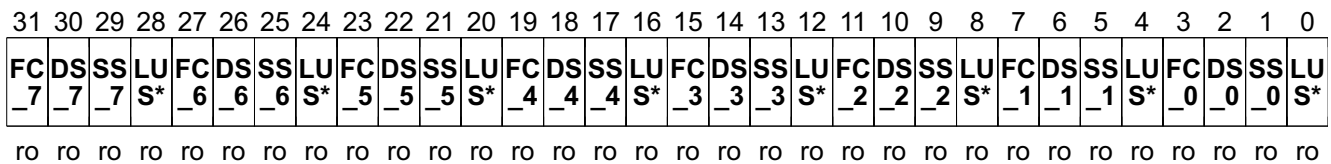

Field	Bits	Type	Description
FC_7	31	ro	Port 7 Flow Control Enable 0 _B , Flow Control Disable 1 _B , 802.3X on for full duplex or back pressure on for half duplex
DS_7	30	ro	Port 7 Duplex Status 0 _B , Half Duplex 1 _B , Full Duplex
SS_7	29	ro	Port 7 Speed Status 0 _B , 10 Mbit/s 1 _B , 100 Mbit/s
LUS_7	28	ro	Port 7 Linkup Status 0 _B , Link is not established 1 _B , Link is established
FC_6	27	ro	Port 6 Flow Control Enable 0 _B , Flow Control Disable 1 _B , 802.3X on for full duplex or back pressure on for half duplex
DS_6	26	ro	Port 6 Duplex Status 0 _B , Half Duplex 1 _B , Full Duplex
SS_6	25	ro	Port 6 Speed Status 0 _B , 10 Mbit/s 1 _B , 100 Mbit/s

Field	Bits	Type	Description
LUS_6	24	ro	Port 6 Linkup Status 0 _B , Link is not established 1 _B , Link is established
FC_5	23	ro	Port 5 Flow Control Enable 0 _B , Flow Control Disable 1 _B , 802.3X on for full duplex or back pressure on for half duplex
DS_5	22	ro	Port 5 Duplex Status 0 _B , Half Duplex 1 _B , Full Duplex
SS_5	21	ro	Port 5 Speed Status 0 _B , 10 Mbit/s 1 _B , 100 Mbit/s
LUS_5	20	ro	Port 5 Linkup Status 0 _B , Link is not established 1 _B , Link is established
FC_4	19	ro	Port 4 Flow Control Enable 0 _B , Flow Control Disable 1 _B , 802.3X on for full duplex or back pressure on for half duplex
DS_4	18	ro	Port 4 Duplex Status 0 _B , Half Duplex 1 _B , Full Duplex
SS_4	17	ro	Port 4 Speed Status 0 _B , 10 Mbit/s 1 _B , 100 Mbit/s
LUS_4	16	ro	Port 4 Linkup Status 0 _B , Link is not established 1 _B , Link is established
FC_3	15	ro	Port 3 Flow Control Enable 0 _B , Flow Control Disable 1 _B , 802.3X on for full duplex or back pressure on for half duplex
DS_3	14	ro	Port 3 Duplex Status 0 _B , Half Duplex 1 _B , Full Duplex
SS_3	13	ro	Port 3 Speed Status 0 _B , 10 Mbit/s 1 _B , 100 Mbit/s
LUS_3	12	ro	Port 3 Linkup Status 0 _B , Link is not established 1 _B , Link is established
FC_2	11	ro	Port 2 Flow Control Enable 0 _B , Flow Control Disable 1 _B , 802.3X on for full duplex or back pressure on for half duplex
DS_2	10	ro	Port 2 Duplex Status 0 _B , Half Duplex 1 _B , Full Duplex

Field	Bits	Type	Description
SS_2	9	ro	Port 2 Speed Status 0 _B , 10 Mbit/s 1 _B , 100 Mbit/s
LUS_2	8	ro	Port 2 Linkup Status 0 _B , Link is not established 1 _B , Link is established
FC_1	7	ro	Port 1 Flow Control Enable 0 _B , Flow Control Disable 1 _B , 802.3X on for full duplex or back pressure on for half duplex
DS_1	6	ro	Port 1 Duplex Status 0 _B , Half Duplex 1 _B , Full Duplex
SS_1	5	ro	Port 1 Speed Status 0 _B , 10 Mbit/s 1 _B , 100 Mbit/s
LUS_1	4	ro	Port 1 Linkup Status 0 _B , Link is not established 1 _B , Link is established
FC_0	3	ro	Port 0 Flow Control Enable 0 _B , Flow Control Disable 1 _B , 802.3X on for full duplex or back pressure on for half duplex
DS_0	2	ro	Port 0 Duplex Status 0 _B , Half Duplex 1 _B , Full Duplex
SS_0	1	ro	Port 0 Speed Status 0 _B , 10 Mbit/s 1 _B , 100 Mbit/s
LUS_0	0	ro	Port 0 Linkup Status 0 _B , Link is not established 1 _B , Link is established

Field	Bits	Type	Description
Count_0	31:0	ro	Port 0 Receive Packet Count

Other Port Registers have a similar structure as [RPC_0](#); see [Table 26](#).

Table 26 Port Registers RPC_x

Register Short Name	Register Long Name	Offset Address	Page Number
RPC_1	Port 1 Receive Packet Count	05 _H	
RPC_2	Port 2 Receive Packet Count	06 _H	
RPC_3	Port 3 Receive Packet Count	07 _H	
RPC_4	Port 4 Receive Packet Count	08 _H	
RPC_5	Port 5 Receive Packet Count	09 _H	
RPC_6	Port 6 Receive Packet Count	0A _H	
RPC_7	Port 7 Receive Packet Count	0B _H	
RPC_8	Port 8 Receive Packet Count	0C _H	
RPBC_0	Port 0 Receive Packet Byte Count	0E _H	
RPBC_1	Port 1 Receive Packet Byte Count	0F _H	
RPBC_2	Port 2 Receive Packet Byte Count	05 _H	
RPBC_3	Port 3 Receive Packet Byte Count	10 _H	
RPBC_4	Port 4 Receive Packet Byte Count	11 _H	
RPBC_5	Port 5 Receive Packet Byte Count	12 _H	
RPBC_6	Port 6 Receive Packet Byte Count	13 _H	
RPBC_7	Port 7 Receive Packet Byte Count	14 _H	
RPBC_8	Port 8 Receive Packet Byte Count	15 _H	
TPC_0	Port 0 Transmit Packet Count	16 _H	
TPC_1	Port 1 Transmit Packet Count	17 _H	
TPC_2	Port 2 Transmit Packet Count	18 _H	
TPC_3	Port 3 Transmit Packet Count	19 _H	
TPC_4	Port 4 Transmit Packet Count	1A _H	
TPC_5	Port 5 Transmit Packet Count	1B _H	
TPC_6	Port 6 Transmit Packet Count	1C _H	
TPC_7	Port 7 Transmit Packet Count	1D _H	
TPC_8	Port 8 Transmit Packet Count	1E _H	
TPBC_0	Port 0 Transmit Packet Byte Count	1F _H	
TPBC_1	Port 1 Transmit Packet Byte Count	20 _H	
TPBC_2	Port 2 Transmit Packet Byte Count	21 _H	
TPBC_3	Port 3 Transmit Packet Byte Count	22 _H	
TPBC_4	Port 4 Transmit Packet Byte Count	23 _H	
TPBC_5	Port 5 Transmit Packet Byte Count	24 _H	
TPBC_6	Port 6 Transmit Packet Byte Count	25 _H	
TPBC_7	Port 7 Transmit Packet Byte Count	26 _H	

Table 26 Port Registers RPC_x

Register Short Name	Register Long Name	Offset Address	Page Number
TPBC_8	Port 8 Transmit Packet Byte Count	27 _H	
CC_0	Port 0 Collision Count	28 _H	
CC_1	Port 1 Collision Count	29 _H	
CC_2	Port 2 Collision Count	2A _H	
CC_3	Port 3 Collision Count	2B _H	
CC_4	Port 4 Collision Count	2C _H	
CC_5	Port 5 Collision Count	2D _H	
CC_6	Port 6 Collision Count	2E _H	
CC_7	Port 7 Collision Count	2F _H	
CC_8	Port 8 Collision Count	30 _H	
EC_0	Port 0 Error Count	31 _H	
EC_1	Port 1 Error Count	32 _H	
EC_2	Port 2 Error Count	33 _H	
EC_3	Port 3 Error Count	34 _H	
EC_4	Port 4 Error Count	35 _H	
EC_5	Port 5 Error Count	36 _H	
EC_6	Port 6 Error Count	37 _H	
EC_7	Port 7 Error Count	38 _H	
EC_8	Port 8 Error Count	39 _H	

6.2 Serial Interface Timing

ADM6999U/UX serial chip internal counter or EEPROM access timing.

- EESK: Similar as MDC signal
- EDI: Similar as MDIO
- ECS: Must keep low

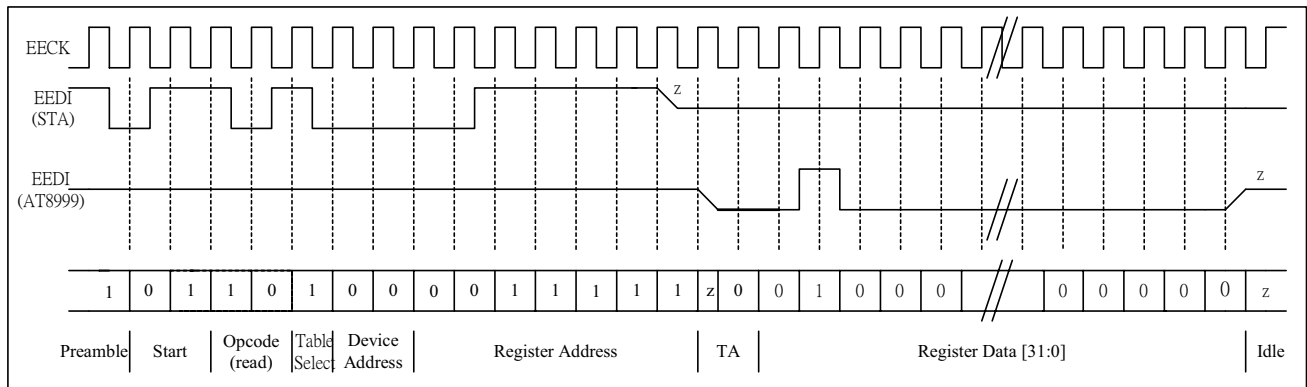

Figure 12 Serial Interface Timing X

- Preamble: At least 32 continuous "1".
- Start: 01(2 bits)
- Opcode: 10 (2 bits, Only supports read command)
- Table select: 1/Counter, 0/ EEPROM (1 bit)
- Register Address: Read Target register address. (7 bits)
- TA: Turn Around.
- Register Data: 32 bit data.
- Counter output bit sequence is bit 31 to bit 0.
- If users read EEPROM then 32 bits data will separate as two EEPROM registers. The sequence is:
 - Register +1, Register (Register is even number).
 - Register, Register-1(Register is Odd number).
 - Example: Read Register 00_H then ADM6999U/UX will drive 01_H & 00_H.Read Register 03_H then ADM6999U/UX will drive 03_H & 02_H
- Idle: EESK must send at least one clock at idle time.

ADM6999U/UX issue Reset internal counter command

- EESK: Similar as MDC signal
- EDI: Similar as MDIO
- ECS: Must keep low

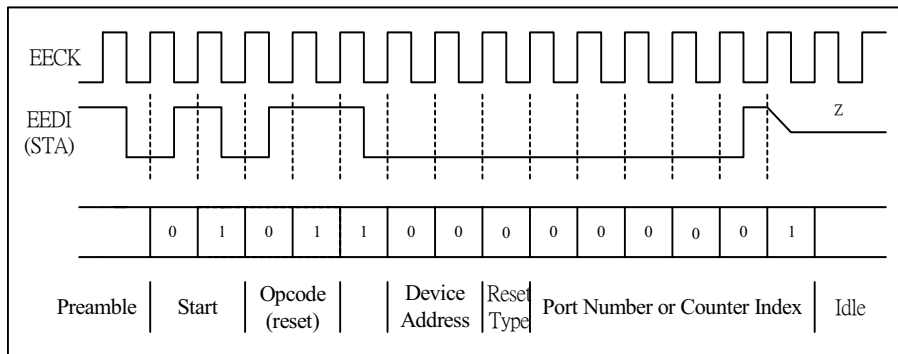

Figure 13 Serial Interface Timing Y

- Preamble: At least 32 continuous "1"
- Start: 01 (2 bits)
- Opcode: 01 (2 bits, Reset command)
- Device Address: Chip physical address as PHYAS[1:0]
- Reset_type: Reset counter by port number or by counter index
 - 1: Clear dedicate port's all counters
 - 0: Clear dedicate counter
- Port_number or counter index: User define clear port or counter
- Idle: EECK must send at least one clock at idle time

7 AC Characteristics

7.1 Power On Reset

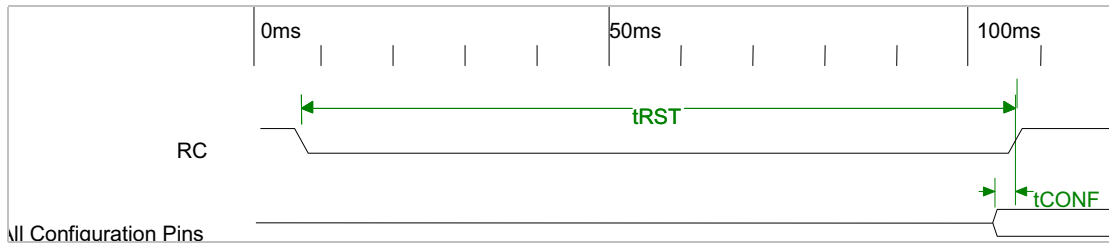

Figure 14 Power On Reset

Table 27 Power On Reset

Parameter	Symbol	Values			Unit	Note / Test Condition
		Min.	Typ.	Max.		
RST Low Period	T_{RST}	100	–	–	ms	–
Start of Idle Pulse Width	T_{CONF}	100	–	–	ns	–

7.2 EEPROM Data Timing

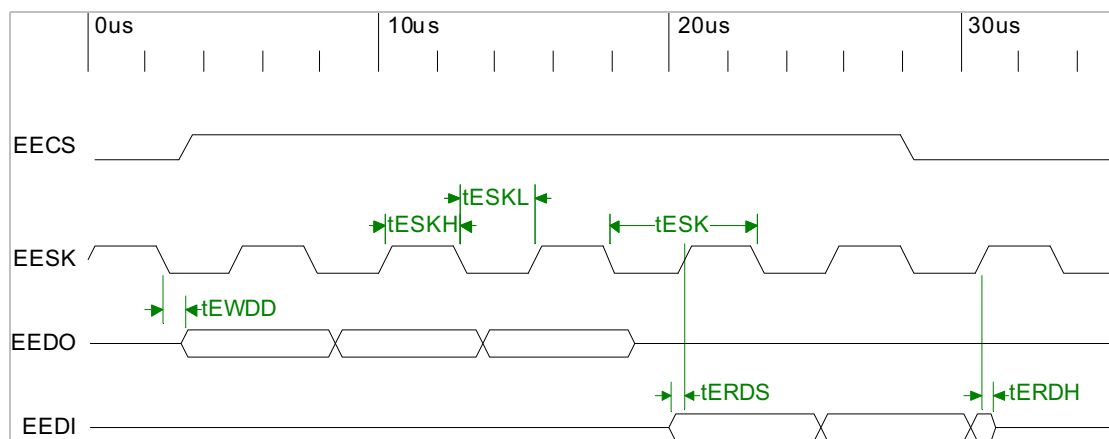

Figure 15 EEPROM Data Timing

Table 28 EEPROM Data Timing

Parameter	Symbol	Values			Unit	Note / Test Condition
		Min.	Typ.	Max.		
EESK Period	T_{ESK}	–	5120	–	ns	–
EESK Low Period	T_{ESKL}	2550	–	2570	ns	–

Table 28 EEPROM Data Timing (cont'd)

Parameter	Symbol	Values			Unit	Note / Test Condition
		Min.	Typ.	Max.		
EESK High Period	T_{ESKH}	2550	–	2570	ns	–
EEDI to EESK Rising Setup Time	T_{ERDS}	10	–	–	ns	–
EEDI to EESK Rising Hold Time	T_{ERDH}	10	–	–	ns	–
EESK Falling to EEDO Output Delay Time	T_{EWDD}	–	–	20	ns	–

7.3 Expansion Bus Receive Signals Timing

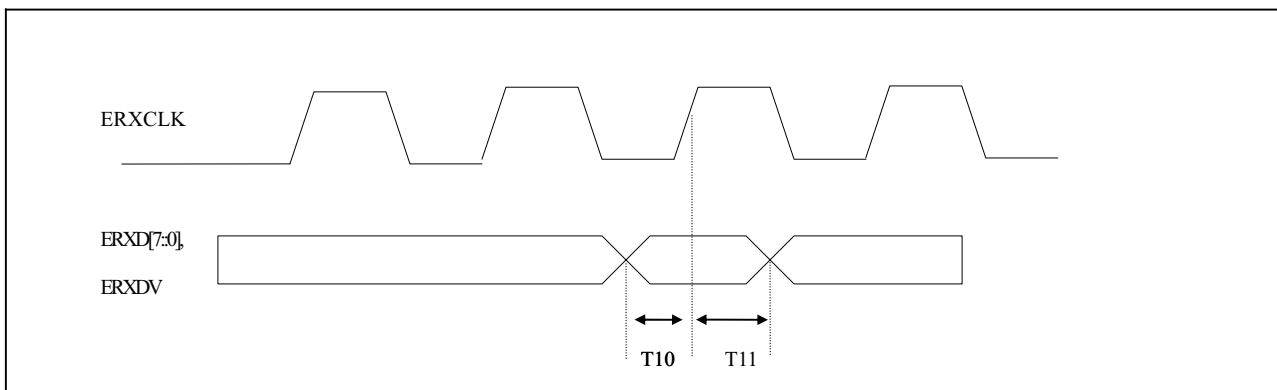

Figure 16 Expansion Bus Receive Signals Timing

Table 29 Expansion Bus Receive Signals Timing

Parameter	Symbol	Values			Unit	Note / Test Condition
		Min.	Typ.	Max.		
Setup Time to Rising ERXCLK	T_{10}	2	–	–	ns	–
Hold Time to Rising ERXCLK	T_{11}	0.5	–	–	ns	–

7.4 Expansion Bus Transmit Signals Timing

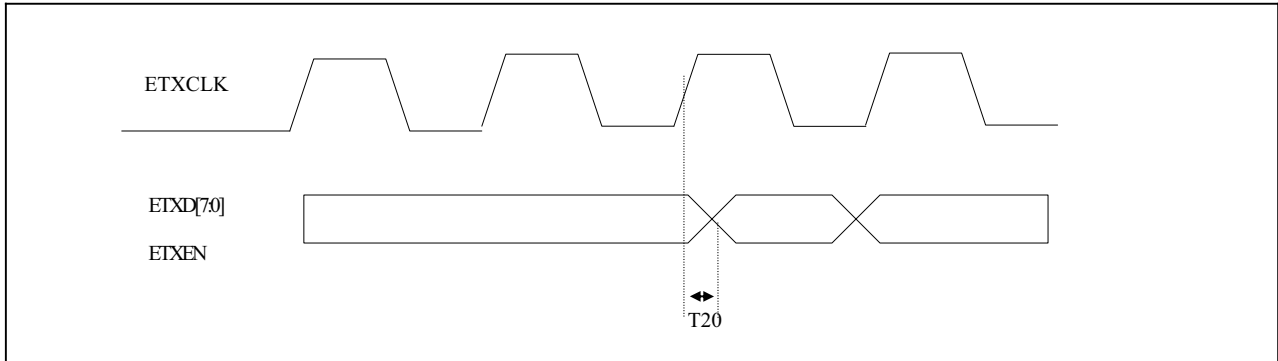

Figure 17 Expansion Bus Transmit Signals Timing

Table 30 Expansion Bus Transmit Signals Timing

Parameter	Symbol	Values			Unit	Note / Test Condition
		Min.	Typ.	Max.		
Data Valid Delay after Rising ETXCLK	T_{20}	1.5	–	4	ns	–

7.5 SMI Timing

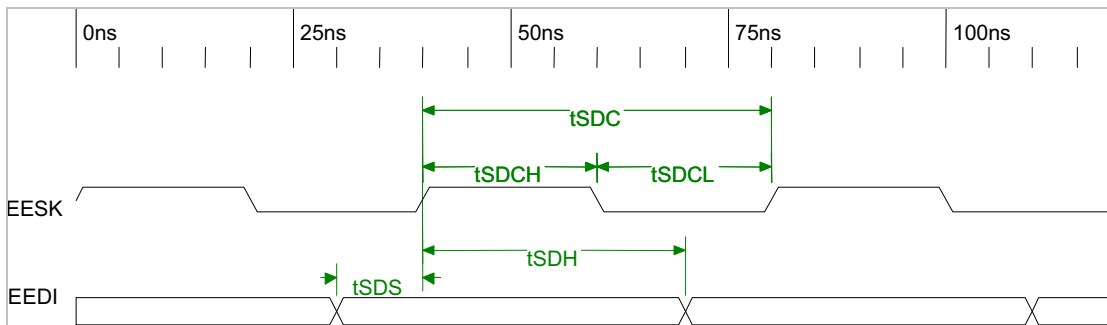

Figure 18 SMI Timing

Table 31 SMI Timing

Parameter	Symbol	Values			Unit	Note / Test Condition
		Min.	Typ.	Max.		
EESK Period	T_{CK}	20	–	–	ns	–
EESK Low Period	T_{CKL}	10	–	–	ns	–
EESK High Period	T_{CKH}	10	–	–	ns	–
EEDI to EESK rising setup time on read/write cycle	T_{SDS}	4	–	–	ns	–
EEDI to EESK rising hold time on read/write cycle	T_{SDH}	2	–	–	ns	–

8 Package

ADM6999U/UX 128 Pin PQFP Outside Dimension

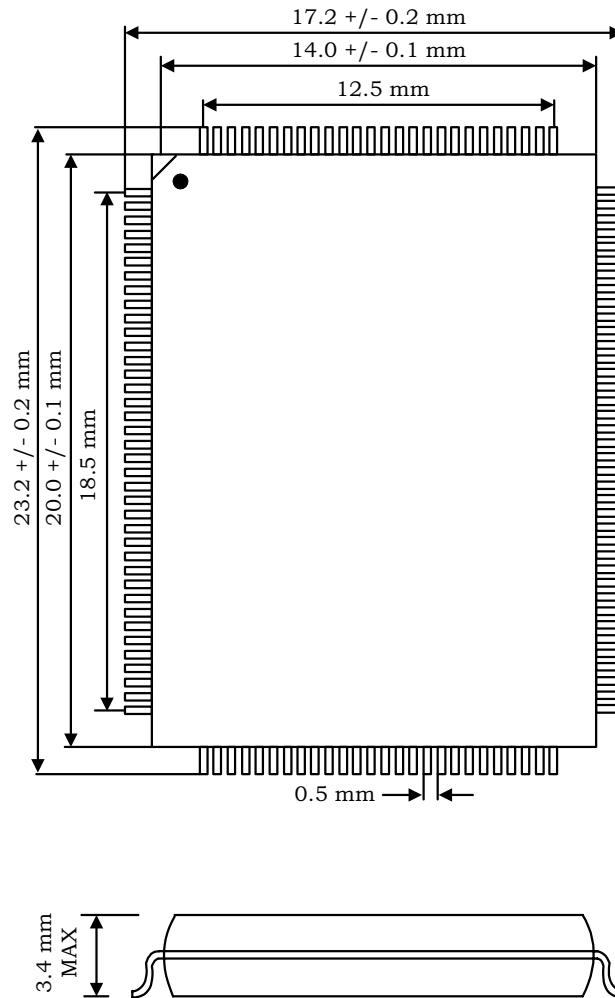

Figure 19 ADM6999U/UX 128 Pin PQFP Outside Dimension

References

- [1]
- [2]
- [3]
- [4]
- [5]
- [6]

Terminology

A

B

www.infineon.com

Published by Infineon Technologies AG