

## Evaluation Board for the **ADF4113HV** Integer-N PLL Frequency Synthesizer

### FEATURES

- Self-contained evaluation board, including synthesizer, VCO, TCXO for reference frequency, and loop filter
- Designed for 1 MHz PFD frequency and 50 kHz loop bandwidth
- Accompanying software allows complete control of synthesizer functions from a PC

### EVALUATION KIT CONTENTS

**EV-ADF4113HVSD1Z** board

CD that includes

- Self-installing software that allows users to control the board and exercise all functions of the device
- Electronic version of the **ADF4113HV** data sheet
- Electronic version of the **UG-165** user guide

### ADDITIONAL EQUIPMENT

- PC running Windows XP or more recent version
- SDP-S** board (system demonstration platform, serial only)
- Spectrum analyzer
- Oscilloscope (optional)

### DOCUMENTS NEEDED

**ADF4113HV** data sheet

### REQUIRED SOFTWARE

Analog Devices Int-N PLL software (Revision 7.3.1 or higher)  
**ADIsimPLL**

### GENERAL DESCRIPTION

This evaluation board allows the user to evaluate the performance of the **ADF4113HV** frequency synthesizer for phase-locked loops (PLLs). Figure 1 shows the board, which contains the **ADF4113HV** synthesizer, an edge-mounted SMA connector for the RF output signal, power supply connectors, a temperature compensated reference oscillator (TCXO) of 25 MHz frequency, and an SDP connector. There is also a loop filter (50 kHz) and a voltage controlled oscillator (VCO), the Mini-Circuits ROS-2260W+, on board.

The package contains Windows®-based software (XP or later) to allow easy programming of the synthesizer.

This evaluation board requires an **SDP-S** board (shown in Figure 1, but not supplied with the evaluation board kit). The **SDP-S** allows software programming of the **ADF4113HV** device.

### EVALUATION BOARD

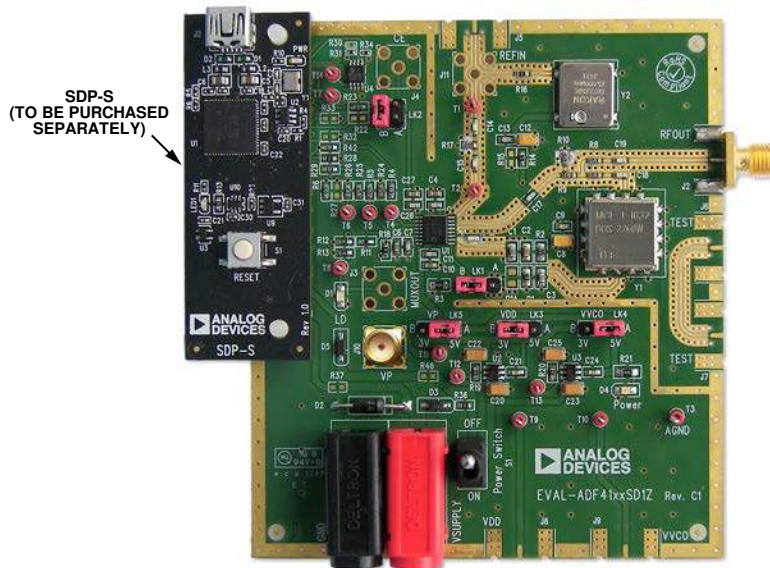

Figure 1. EV-ADF4113HVSD1Z with SDP-S

**TABLE OF CONTENTS**

Features .....	1	Input Signals.....	4
Evaluation Kit Contents.....	1	Output Signals .....	4
Additional Equipment .....	1	Default Operation and Jumper Selection Settings.....	5
Documents Needed.....	1	System Demonstration Platform (SDP) .....	5
Required Software .....	1	Evaluation Board Setup Procedure .....	6
General Description .....	1	Software Installation .....	6
Evaluation Board .....	1	Evaluation Board Software.....	10
Revision History .....	2	Evaluation and Test .....	12
Quick Start Guide.....	3	Evaluation Board Schematics and Artwork.....	13
Evaluation Board Hardware.....	4	Bill of Materials.....	20
Power Supplies .....	4	Related Links.....	21

**REVISION HISTORY**

**10/12—Rev. 0 to Rev. A**

Changed EVAL-ADF4113HVEB1Z to  
 EV-ADF4113HVSD1Z ..... Universal  
 Replaced All Sections, Tables, and Figures ..... Universal

**6/11—Revision 0: Initial Version**

## QUICK START GUIDE

Follow these steps to quickly evaluate the [ADF4113HV](#) device:

1. Install the Analog Devices Int-N PLL software.
2. Connect the [SDP-S](#) motherboard to the [EV-ADF4113HVSD1Z](#) board and to the PC.
3. Follow the hardware driver installation procedure that appears if you are using Windows XP.
4. Connect the power supplies to banana connectors (6 V to 12 V).
5. Connect 15 V to  $V_p$ .
6. Run the Analog Devices Int-N PLL software.
7. Select the SDP board and the [ADF4113HV](#) device in the **Select Device and Connection** tab in the main window of the evaluation board software.
8. Click the **Main Controls** tab. Set the correct values for **Reference Frequency** (25 MHz) and **RF VCO Output Frequency** (ranging from 1200 MHz to 2100 MHz), and then click **Write All Latches**.
9. Connect the spectrum analyzer to J2.
10. Measure the results.

## EVALUATION BOARD HARDWARE

The evaluation board requires the use of an [SDP-S](#) motherboard to program the device. The [SDP-S](#) board is not included with the evaluation board and must be purchased separately. The [EV-ADF4113HVSD1Z](#) schematics are shown in Figure 21 to Figure 23.

### POWER SUPPLIES

The board is powered from external banana connectors and an external 15 V source connected to the VP SMA connector. The supply voltage on the banana connectors can vary between 6 V and 12 V. The power supply circuit provides 3.0 V to  $V_{DD}$  on the board (which supplies the [ADF4113HV](#)  $AV_{DD}$  and  $DV_{DD}$  pins) and allows the user to choose either 3.0 V or 5 V for the VCO supply. The default settings are 3.0 V for the [ADF4113HV](#)  $V_{DD}$  and 5 V for the VCO supply. Note that  $V_{DD}$  should never exceed 3.3 V because exceeding this voltage level may damage the device. The supply pin,  $V_P$ , must be driven externally via J10 with 15 V.

External power supplies can be used to directly drive the device. In this case, the user must insert SMA connectors as shown in Figure 2.

### INPUT SIGNALS

The necessary reference input comes from an on-board temperature compensated crystal oscillator (TCXO) of 25 MHz frequency.

Alternatively, this can be sourced from an external generator. In this case, remove R16 and R14 to disconnect the TCXO from the supply and from the reference path, insert Connector J11 or the J5 edge-mount connector, and connect the external generator to the connector. A low noise, high slew rate reference source is best for achieving the stated performance of the [ADF4113HV](#).

Digital SPI signals are supplied through the SDP connector, J1. Using the [SDP-S](#) board is recommended. The [SDP-Blackfin](#) ([SDP-B](#)) board can also be used, but Resistor R57 must be removed from the [SDP-B](#) board. Some additional spurious low frequencies may appear if the [SDP-B](#) connector is used.

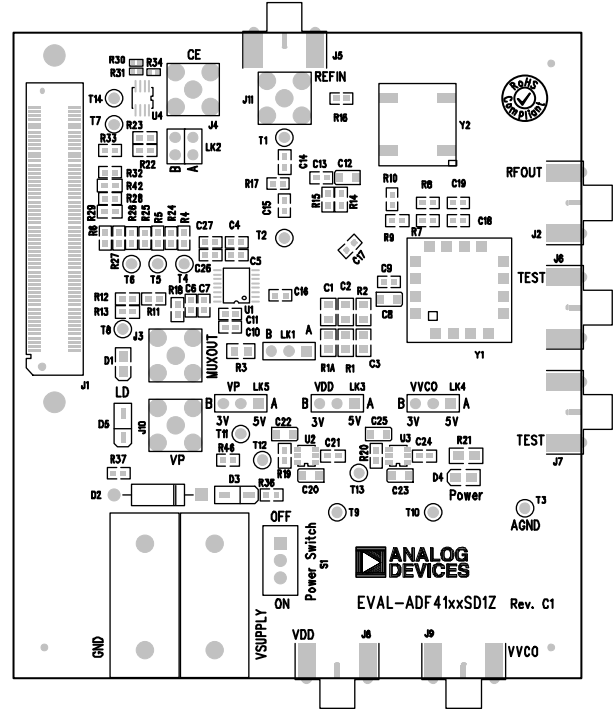

Figure 2. Evaluation Board Silkscreen

### OUTPUT SIGNALS

All components necessary for local oscillator (LO) generation are inserted on board. The PLL is made up of the [ADF4113HV](#) synthesizer, a passive loop filter, and the VCO. This board is supplied with a VCO ROS-2260W+ from Mini-Circuits, which covers a frequency range from 1290 MHz to 2260 MHz. A low-pass filter of 50 kHz loop bandwidth is inserted between the charge pump output and the VCO input. The VCO output is available at RFOUT through a standard SMA connector, J2. The MUXOUT signal can be monitored at Test Point T8 or at SMA Connector J3.

## DEFAULT OPERATION AND JUMPER SELECTION SETTINGS

Link positions and their respective functions are outlined in Table 1.

**Table 1. Link Positions and Functions**

Link	Position	Options	Description
LK1	A	R1A	Not used
	B	RSET	Normal operation
LK2	A	GND	Not used
	B	VDD	Normal operation
LK3 (V <sub>DD</sub> )	A	5 V	Not used
	B	3 V	Normal operation
LK4 (V <sub>VCO</sub> )	A	5 V	VCO supply (5 V)
	B	3 V	VCO supply (3 V)

## SYSTEM DEMONSTRATION PLATFORM (SDP)

The system demonstration platform (SDP) is a series of controller boards, interposer boards, and daughter boards that can be used for easy, low cost evaluation of Analog Devices, Inc., components and reference circuits. It is a reusable platform whereby a single controller board can be reused in various daughter board evaluation systems.

Controller boards connect to a PC via a USB 2.0 high speed port and provide a range of communication interfaces on a 120-pin connector. The pinout for this connector is strictly defined. A receptacle for this 120-pin connector is included on all SDP daughter boards, component evaluation boards, and Circuits from the Lab® reference circuit boards. There are two controller boards in the platform: the [SDP-B](#), which is based on the Blackfin® [ADSP-BF527](#), and the [SDP-S](#), which is a serial interface only controller board. The [SDP-S](#) has a subset of the [SDP-B](#) functionality.

Interposer boards route signals between the SDP 120-pin connector and a second connector. When the second connector is also a 120-pin connector, the interposer can be used for signal monitoring of the 120-pin connector signals. Alternatively, the second connector allows SDP platform elements to be integrated into a second platform, for example, the BeMicro SDK. More information on the SDP can be found at [www.analog.com/sdp](http://www.analog.com/sdp).

## EVALUATION BOARD SETUP PROCEDURE

### SOFTWARE INSTALLATION

Use the following steps to install the SDP drivers and Analog Devices Int-N PLL software.

1. Install the Analog Devices Int-N PLL software by double-clicking **ADI\_Int-N\_Setup.msi**. Note that the version number may be added to the file name.  
 If you are using Windows XP, follow the instructions in the Windows XP Software Installation Guide section (see Figure 3 to Figure 7).  
 If you are using Windows Vista or Windows 7, follow the instructions in the Windows Vista and Windows 7 Software Installation Guide section (see Figure 8 to Figure 12).  
 Note that the software requires Microsoft Windows Installer and Microsoft .NET Framework 3.5 (or higher). The installer connects to the Internet and downloads Microsoft .NET Framework automatically. Alternatively, before running the **ADI\_Int-N\_Setup.msi**, both the installer and .NET Framework can be installed from the CD provided in the evaluation board kit.
2. Connect your SDP board to **EV-ADF4113HVSD1Z** and to the USB port of the PC using the supplied USB cable. If you are using Windows XP, follow the steps in the Windows XP Driver Installation Guide section (see Figure 13 to Figure 16). If you are using Windows Vista or Windows 7, the drivers install automatically.

#### Windows XP Software Installation Guide

1. Click **Next**.

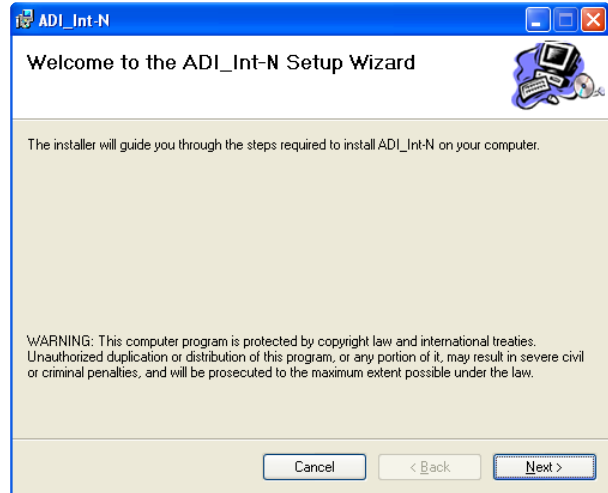

Figure 3. Windows XP Int-N PLL Software Installation, Setup Wizard

2. Choose an installation directory and click **Next**.

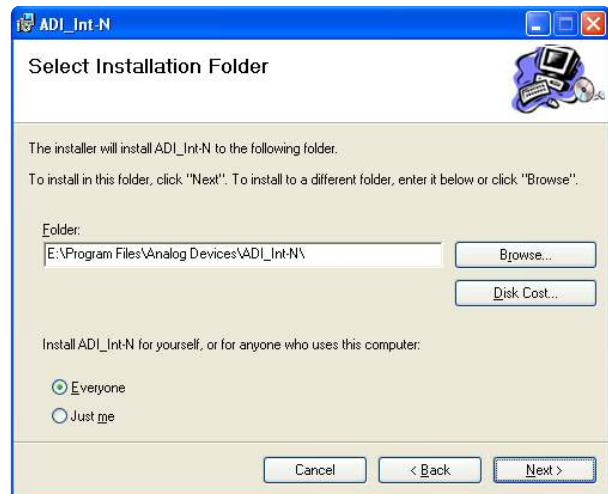

Figure 4. Windows XP Int-N PLL Software Installation, Select Installation Folder

3. Click **Next**.

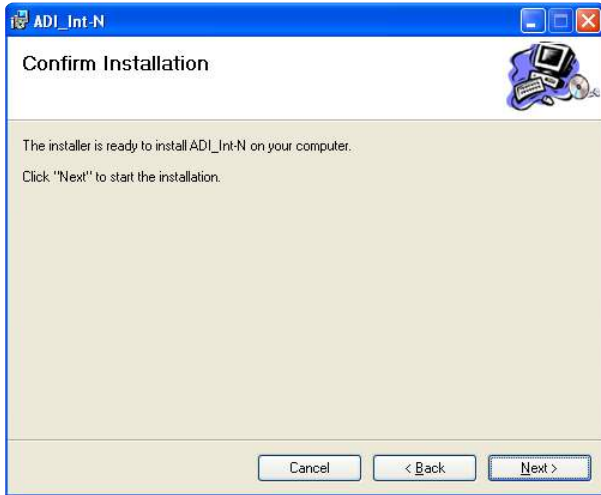

Figure 5. Windows XP Int-N PLL Software Installation, Confirm Installation

4. Click **Continue Anyway**.

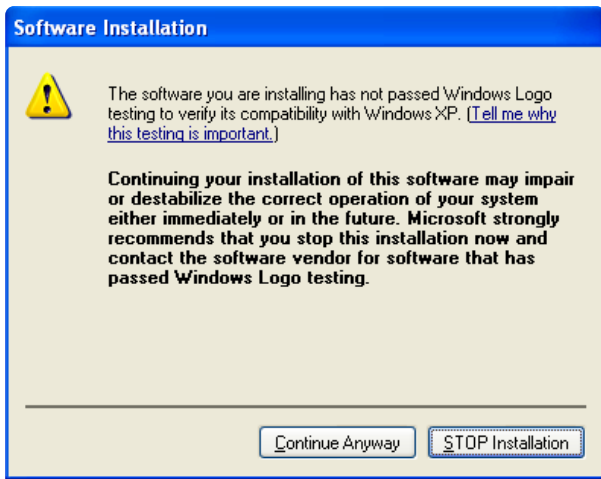

Figure 6. Windows XP Int-N PLL Software Installation, Logo Testing

5. Click **Close**.

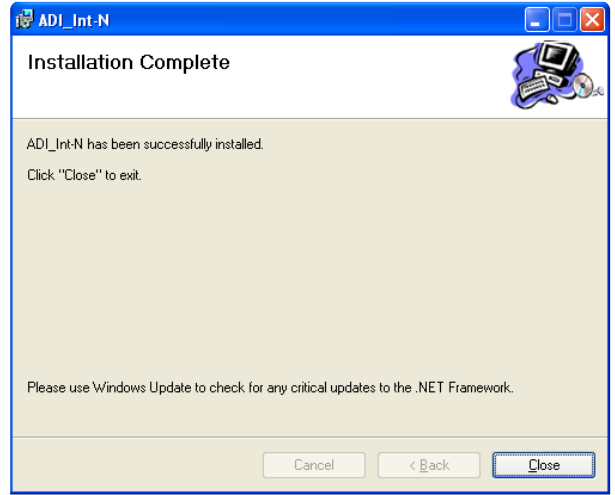

Figure 7. Windows XP Int-N PLL Software Installation, Installation Complete

**Windows Vista and Windows 7 Software Installation Guide**

1. Click **Next**.



Figure 8. Windows Vista/Windows 7 Int-N PLL Software Installation, Setup Wizard

2. Choose an installation directory and click **Next**.

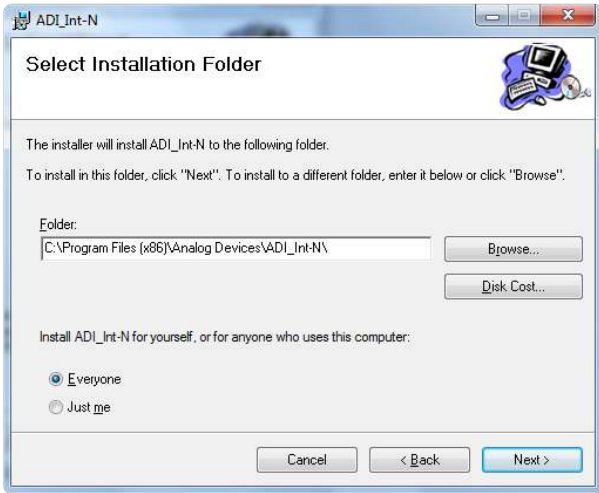

09150-009

Figure 9. Windows Vista/Windows 7 Int-N PLL Software Installation, Select Installation Folder

3. Click **Next**.

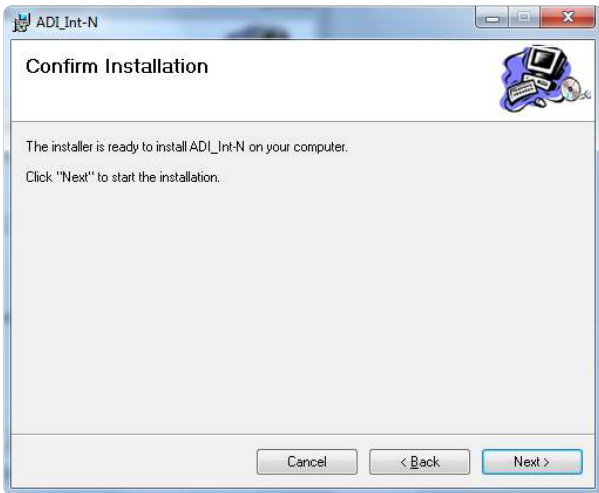

09150-010

Figure 10. Windows Vista/Windows 7 Int-N PLL Software Installation, Confirm Installation

4. Click **Install**.

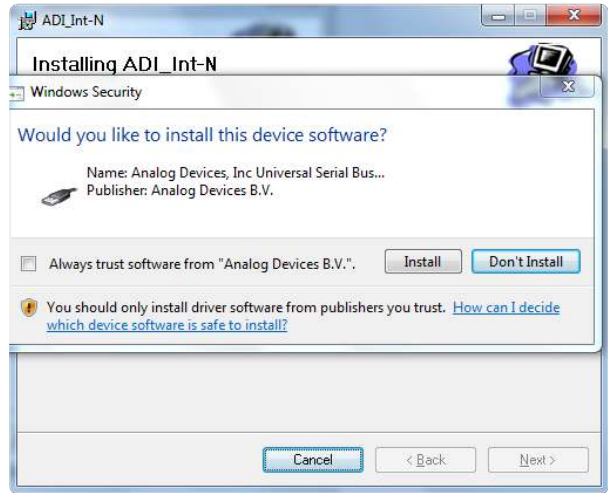

09150-011

Figure 11. Windows Vista/Windows 7 Int-N PLL Software Installation, Start Installation

5. Click **Close**.

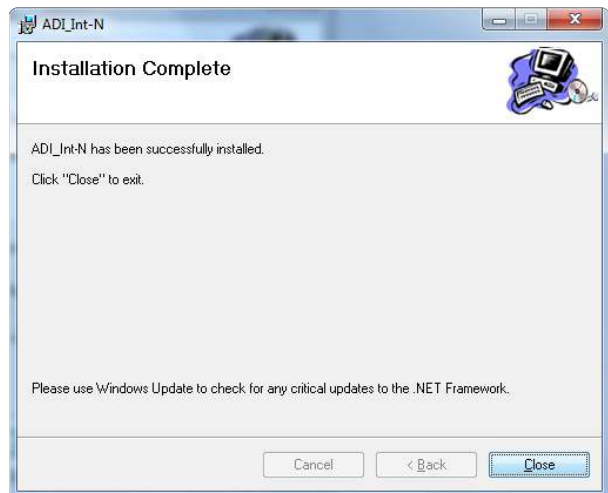

09150-012

Figure 12. Windows Vista/Windows 7 Int-N PLL Software Installation, Installation Complete



**Windows XP Driver Installation Guide**

1. Choose **Yes, this time only** and click **Next**.



Figure 13. Windows XP SDP-S Board Driver Installation, Found New Hardware Wizard

2. Click **Next**.

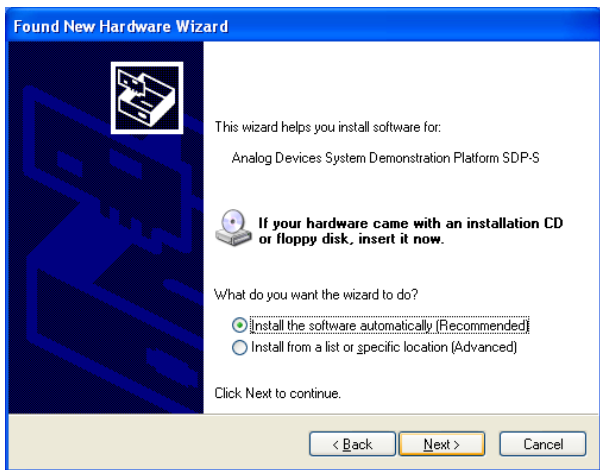

Figure 14. Windows XP SDP-S Board Driver Installation, Installation Options

3. Wait for the installation program to copy all the necessary files.

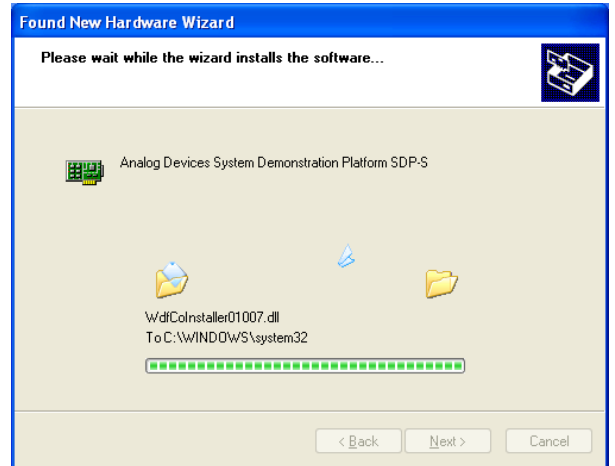

Figure 15. Windows XP SDP-S Board Driver Installation, Progress

4. Click **Finish**.

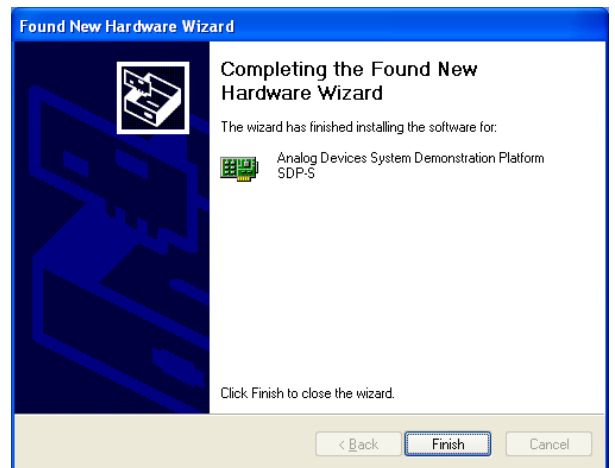

Figure 16. Windows XP SDP-S Board Driver Installation, Complete Installation

## EVALUATION BOARD SOFTWARE

The control software for the [EV-ADF4113HVSD1Z](#) is provided on a CD included in the evaluation board kit. To install the software, see the Software Installation section.

To run the software, click the **ADI PLL Int-N** file on the desktop or from the **Start** menu.

On the **Select Device and Connection** tab, choose the device and connection method, and then click **Connect**.

Confirm that **SDP board connected** is displayed at the bottom left of the window (see Figure 17). If this message is not displayed, the software cannot connect to the evaluation board.

Note that when the board is connected, there is about a 5 sec to 10 sec delay before the status label changes.

From the **File** menu, the current settings can be saved to and loaded from a text file.

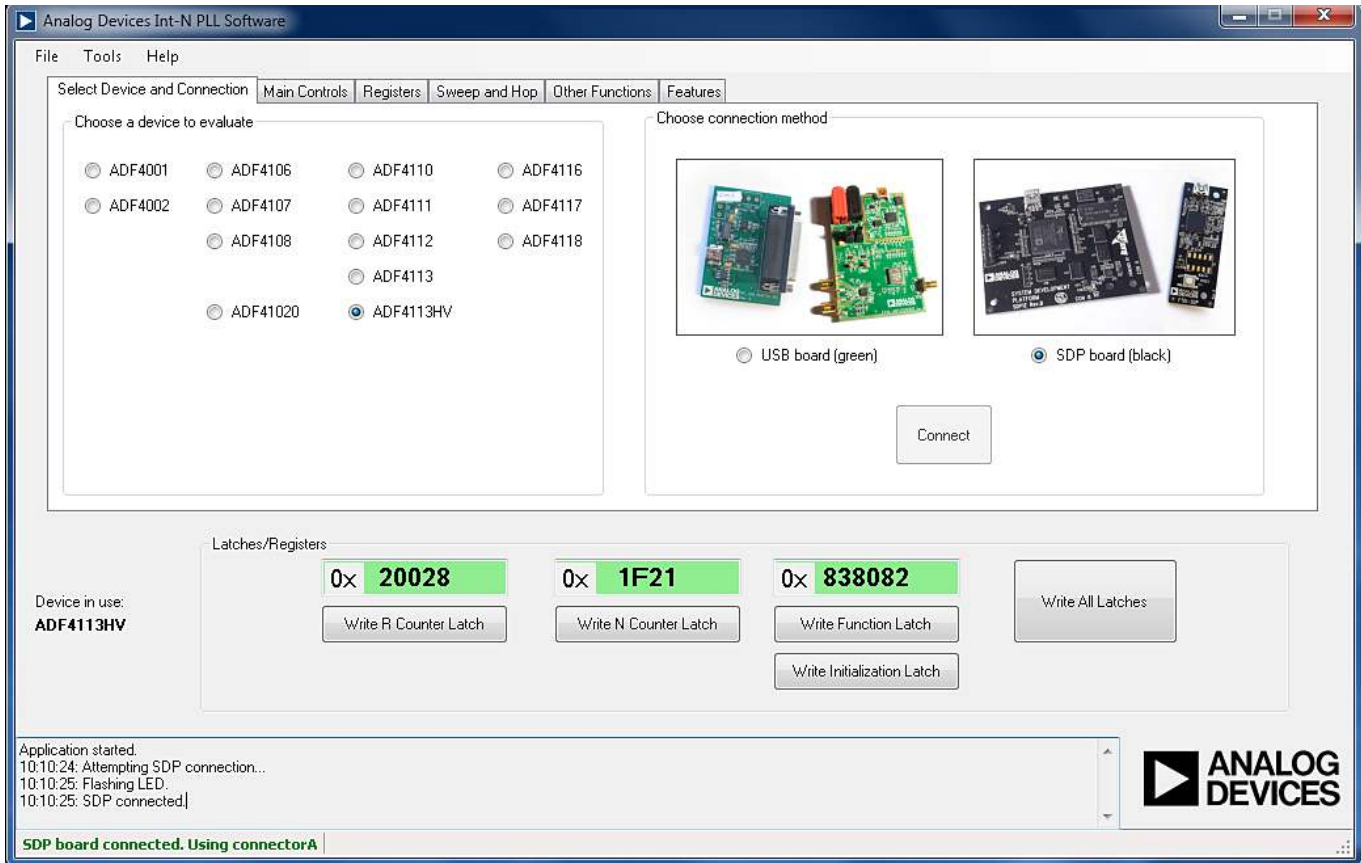

Figure 17. Int-N PLL Software, Main Window—Select Device and Connection

The **Main Controls** tab controls the PLL settings (see Figure 18). Use the **Reference Frequency** text box to set the correct reference frequency and the reference frequency divider. The default reference frequency in this box is 10 MHz; it must be changed to 25 MHz if the on-board reference oscillator is used.

Use the **RF Settings** section to control the output frequency. You can type the desired output frequency in the **RF VCO Output Frequency** text box (in megahertz).

In the **Registers** tab, you can manually input the desired value to be written to the registers.

In the **Sweep and Hop** tab, you can make the device sweep a range of frequencies or hop between two set frequencies.

In the **Latches/Registers** section at the bottom of the **Main Controls** tab of the main window, the values to be written to each register are displayed. If the background on the text box is green, the value displayed is different from the value actually on the device. Click **Write R Counter Latch**, **Write N Counter Latch**, **Write Function Latch**, or **Write Initialization Latch** to write the value displayed to the device.

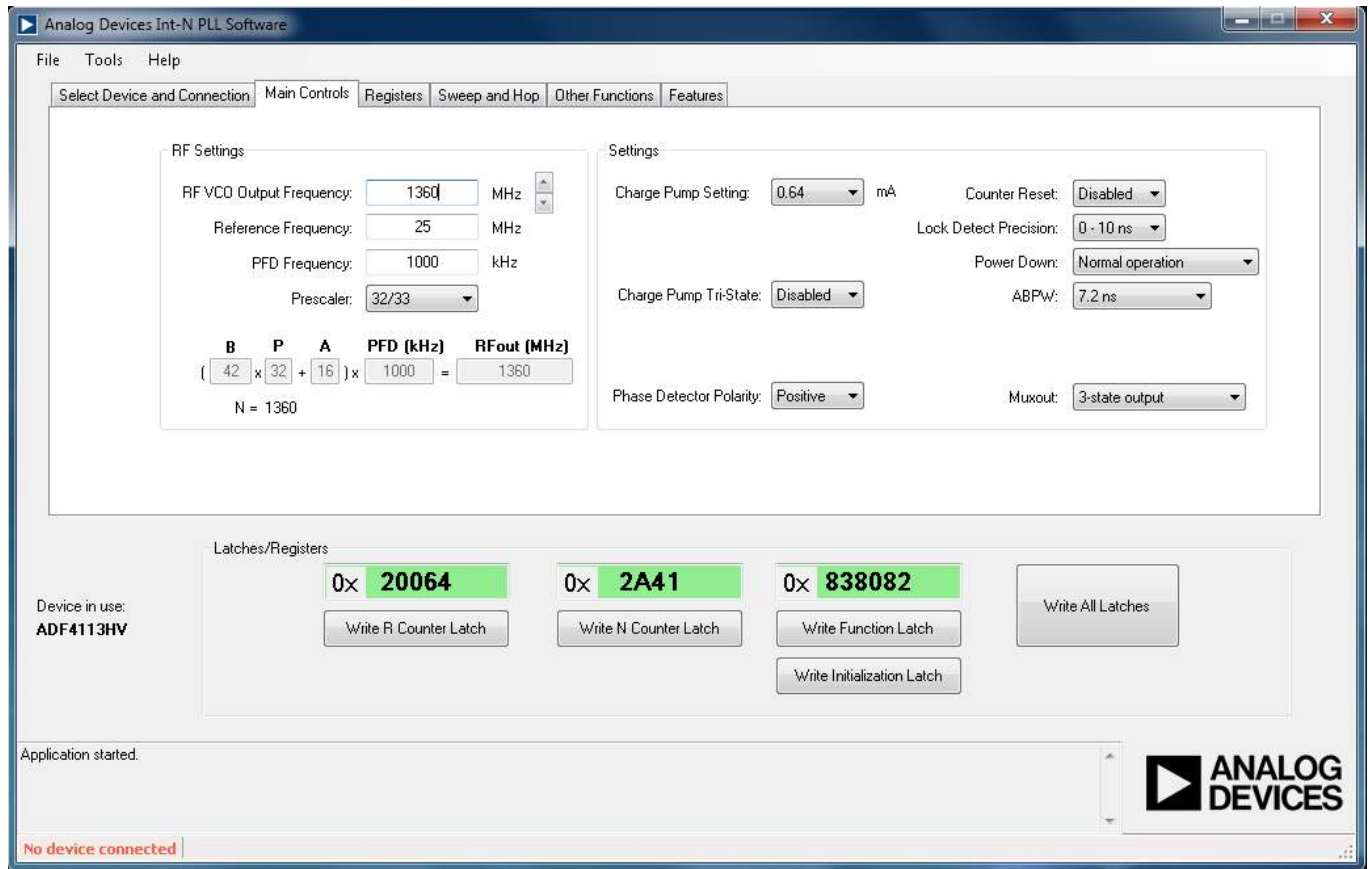

Figure 18. Int-N PLL Software, Main Window—Main Controls

## EVALUATION AND TEST

To evaluate and test the performance of the [ADF4113HV](#), use the following procedure:

1. Install the Int-N PLL software.
2. Connect the [SDP-S](#) connector to the [EV-ADF4113HVSD1Z](#) and to a PC using the supplied USB cable. If you are using Windows XP, follow the hardware driver installation procedure that appears.
3. Connect a spectrum analyzer to Connector J2.
4. Run the Int-N PLL software.
5. Select the SDP board and the [ADF4113HV](#) device in the **Select Device and Connection** tab in the main window of the evaluation board software.
6. From the **Main Controls** tab in the main window of the evaluation board software, set the desired frequency in the **RF VCO Output Frequency** text box. Set the **PFD Frequency** text box to 1000 kHz, and program the **Reference Frequency** text box to 25 MHz. See Figure 20 for the suggested measurement setup.
7. Measure the output spectrum. Figure 19 shows a phase noise plot at 1360 MHz output frequency.

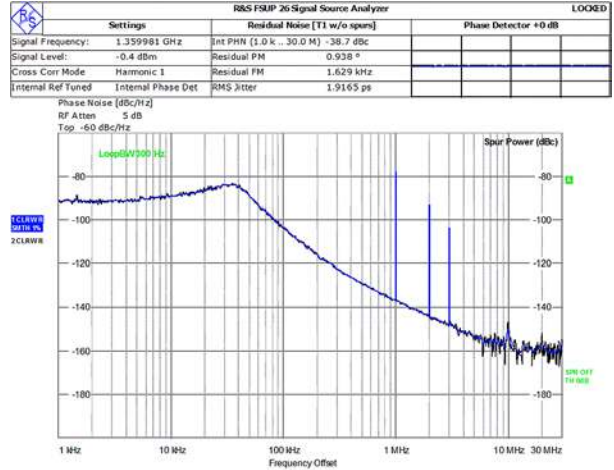

Figure 19. Signal Source Analyzer Display

09150-019

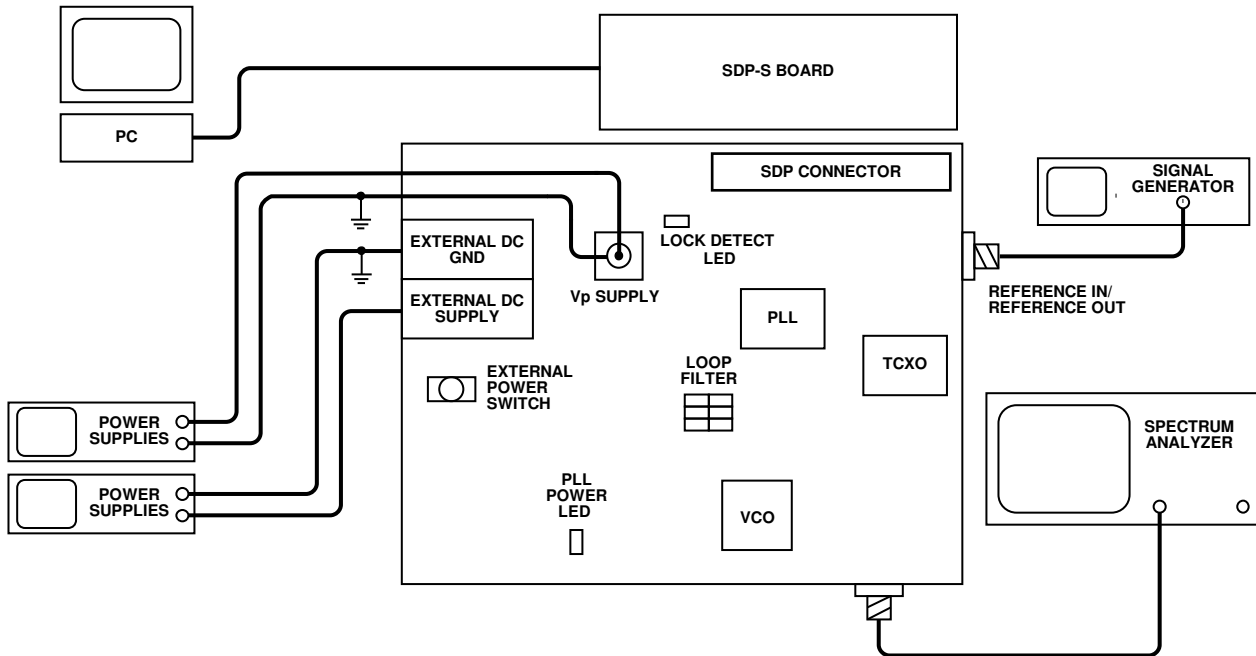
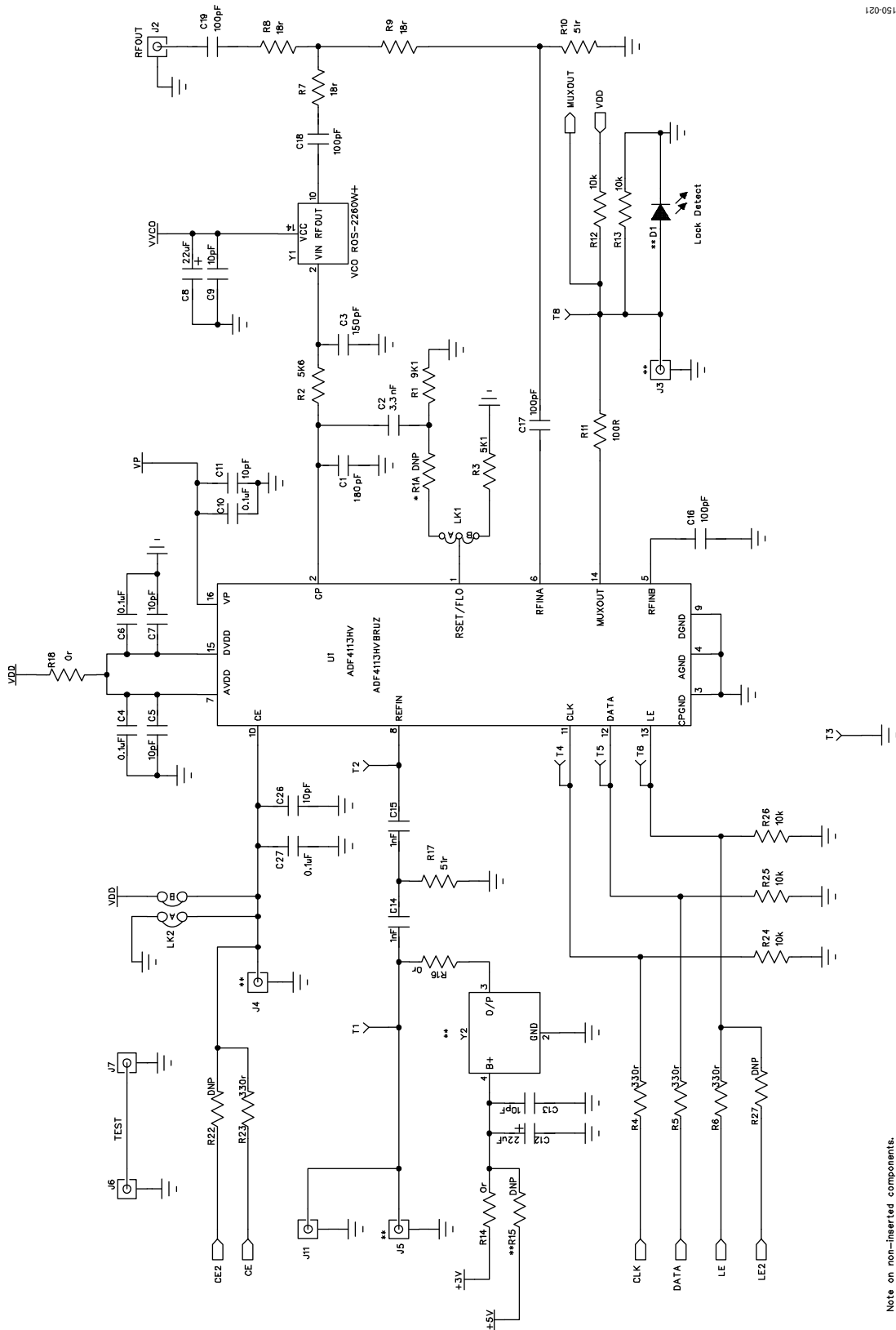

Figure 20. Typical Evaluation Setup

09150-020

EVALUATION BOARD SCHEMATICS AND ARTWORK

120-05160



Note on non-inserted components.  
 \* - These components can be inserted by the user for expansion purposes.

Figure 21. Evaluation Board Schematic (Page 1)

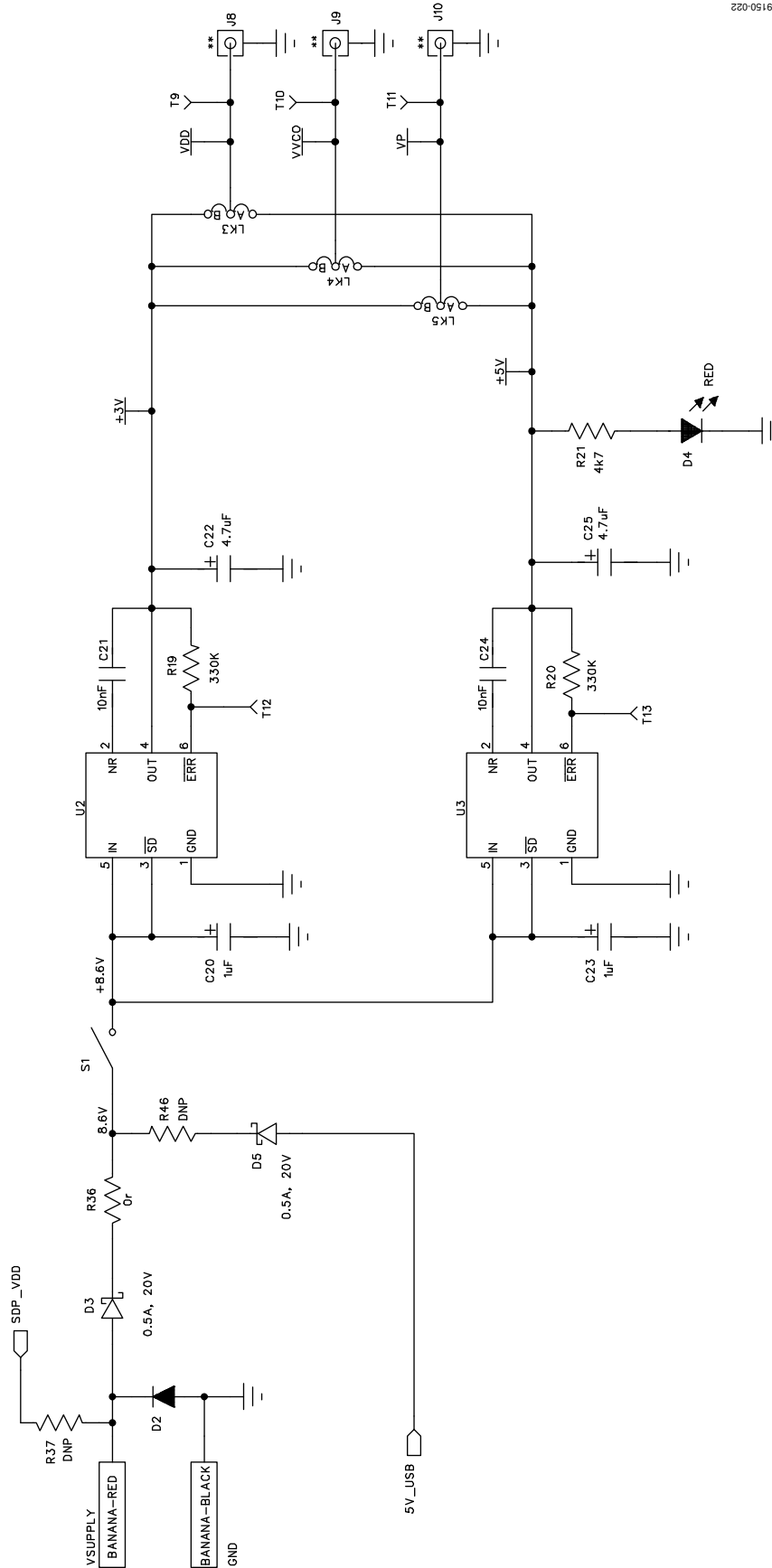

09150-022

Figure 22. Evaluation Board Schematic (Page 2)

09150-023

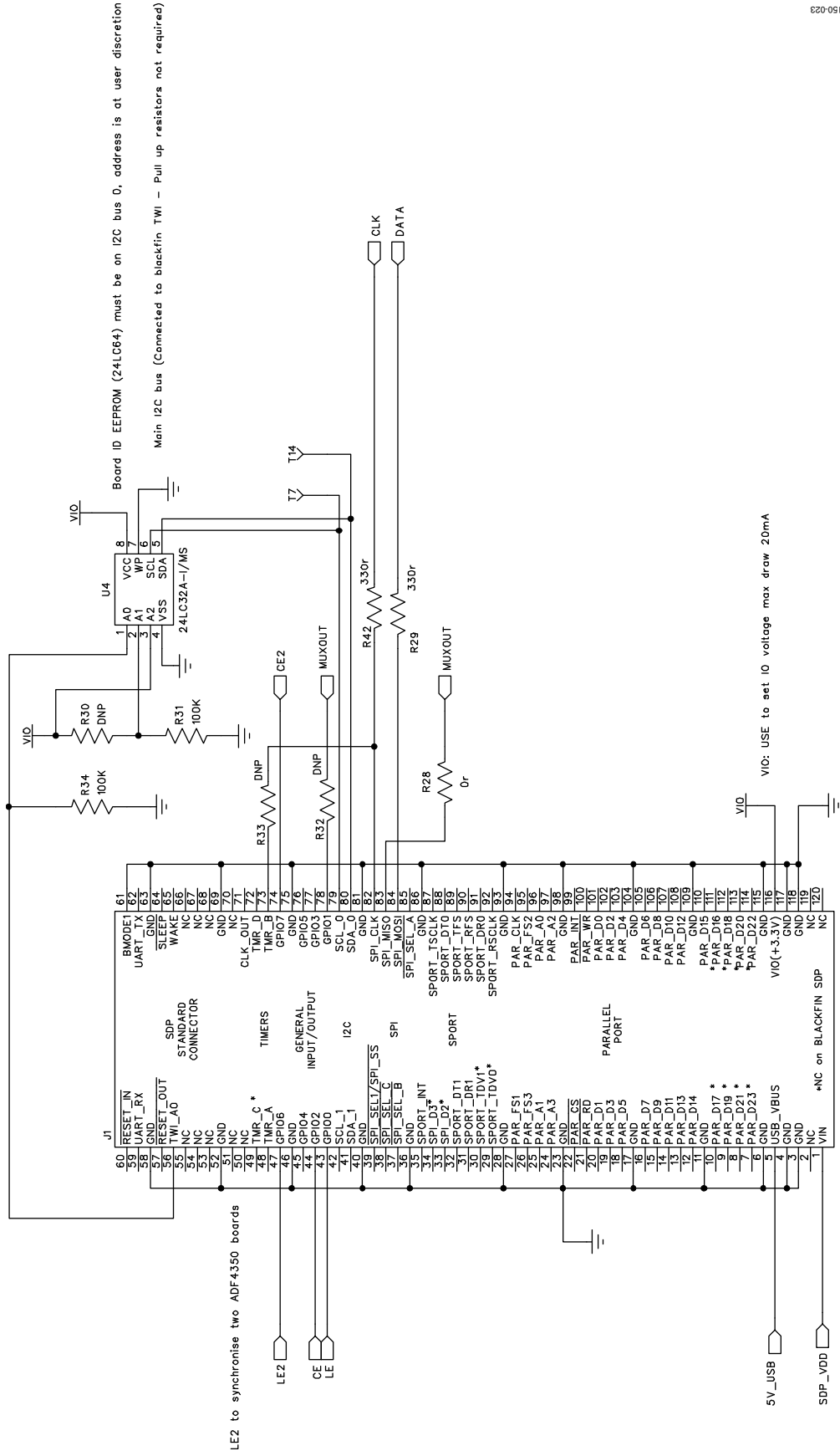
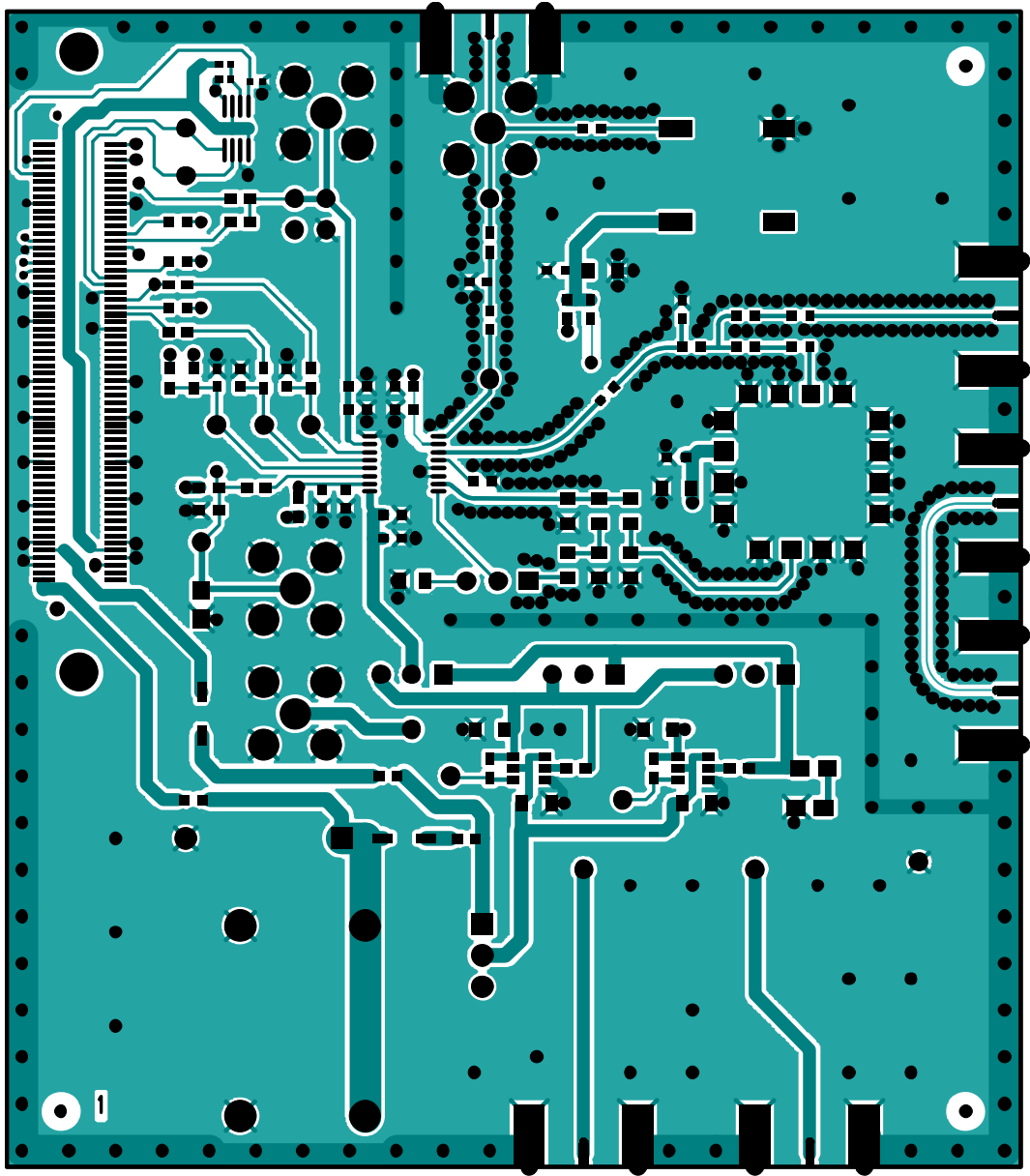

Figure 23. Evaluation Board Schematic (Page 3)



00150-024

Figure 24. Layer 1 (Component Side)



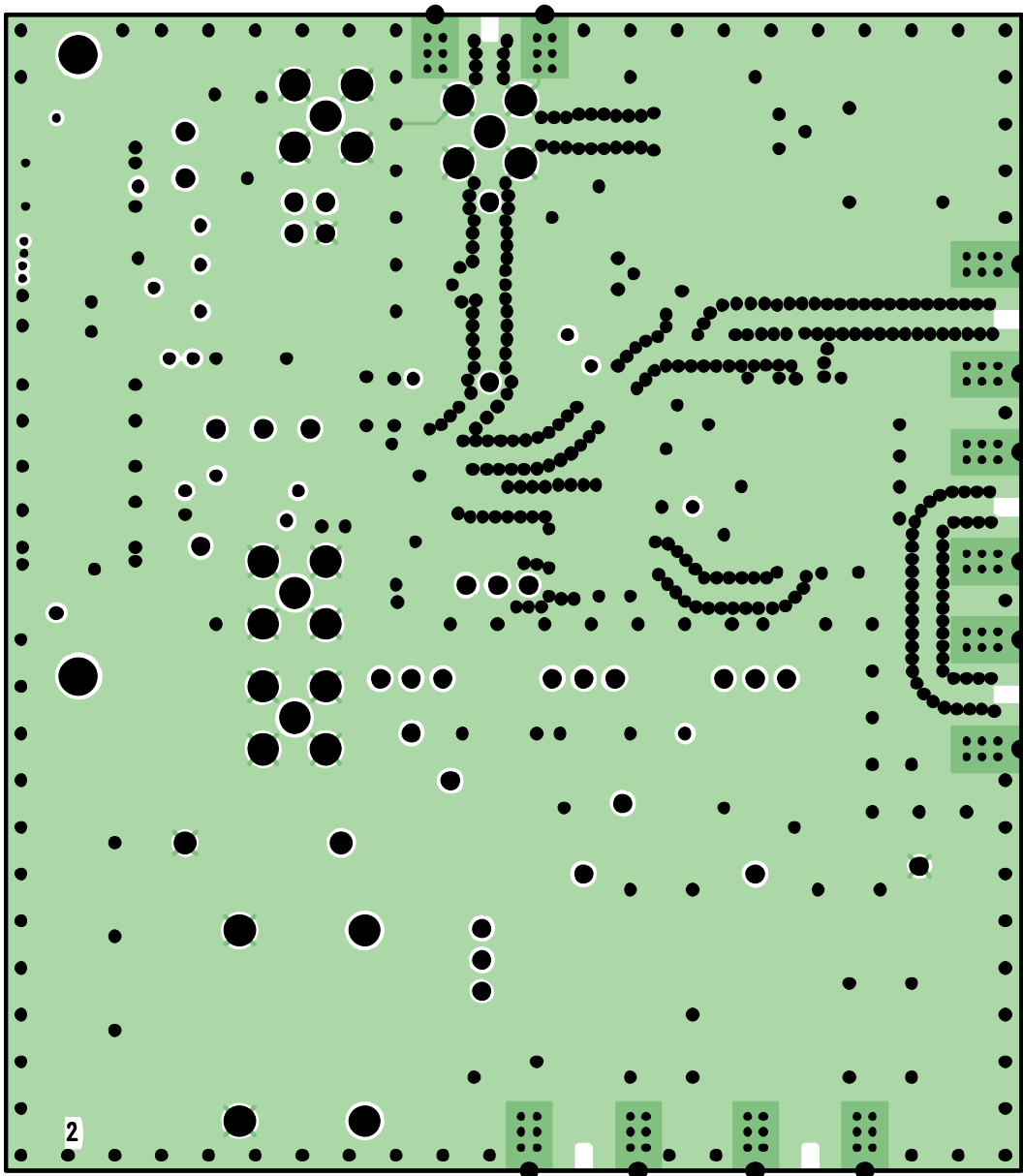

09150-025

Figure 25. Layer 2 (Ground Plane)

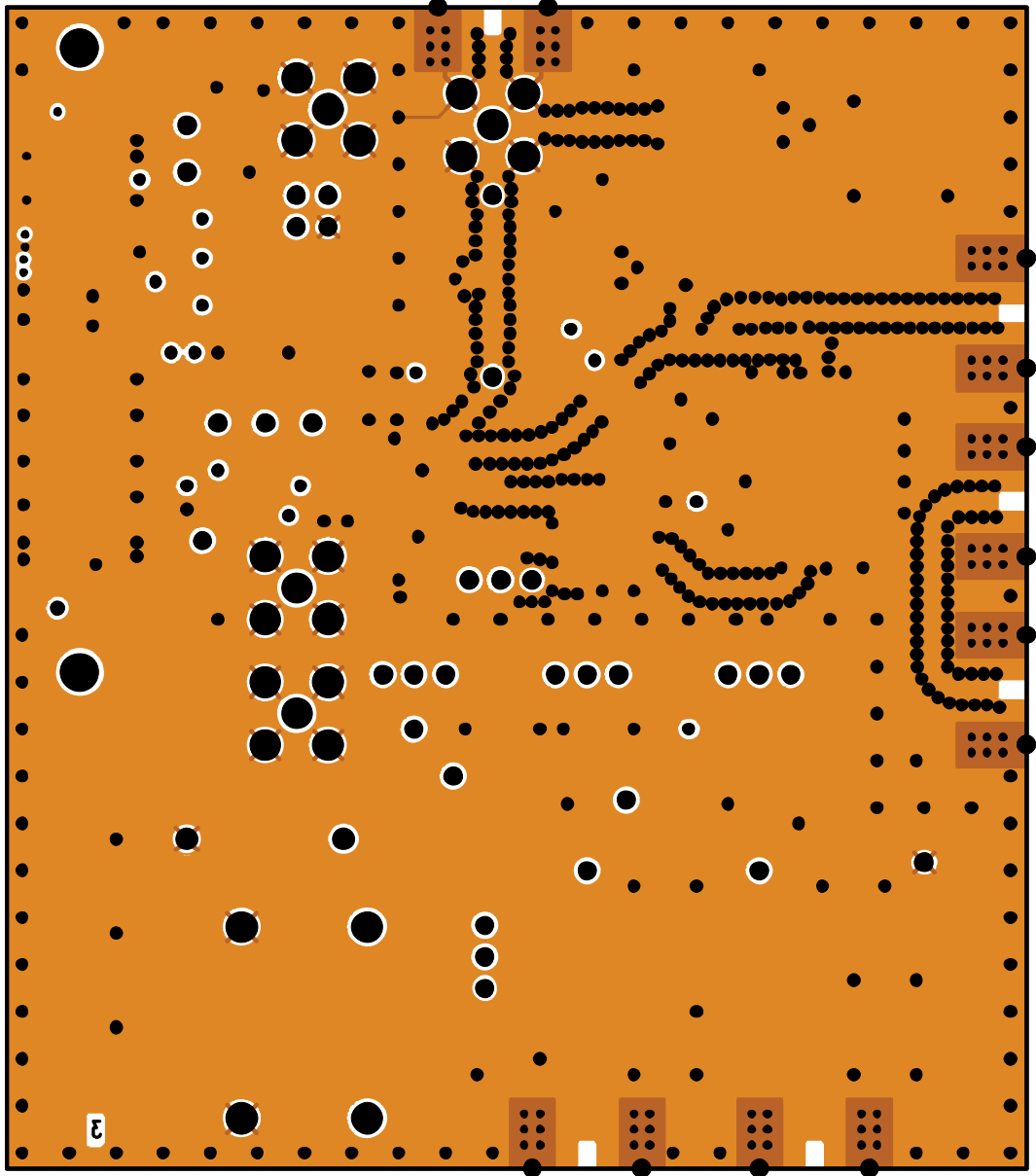

00150-026

Figure 26. Layer 3 (Power Plane)

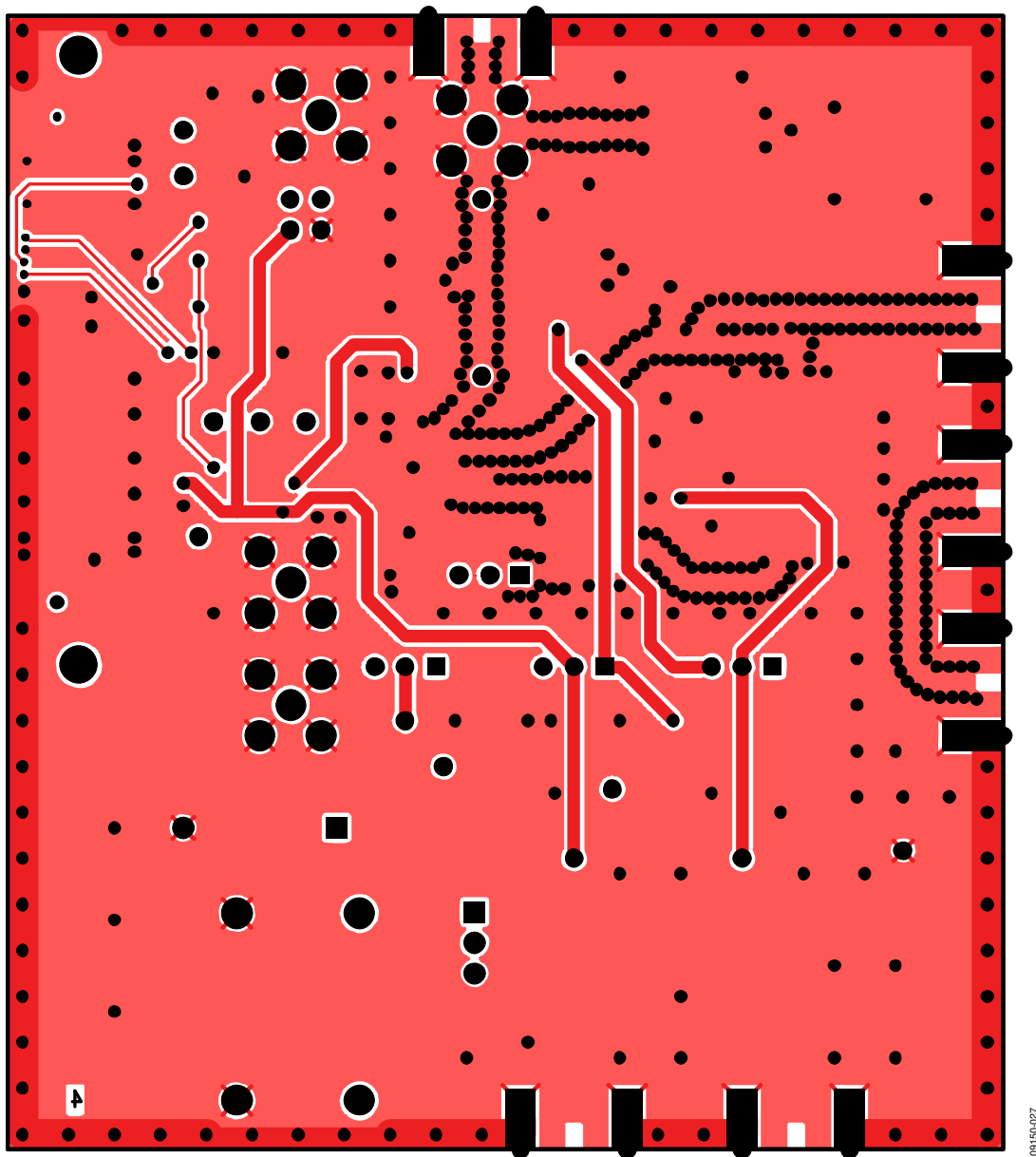

Figure 27. Layer 4 (Solder Side)

09150-027

## BILL OF MATERIALS

Table 2.

Reference Designator	Part Description	Manufacturer/Part No.
C1	Capacitor, 0603, 180 pF, 50 V, COG	Kemet C0603C181J5GAC
C2	Capacitor, 0603, 3.3 nF, 50 V, COG	TDK C1608C0G1H332J
C3	Capacitor, 0603, 150 pF, 50 V, COG	Kemet C0603C151J5GAC AUTO
C4, C6, C10, C27	Capacitor, 0603, 0.1 $\mu$ F, 16 V	AVX CM105X7R104K16AT
C5, C7, C9, C11, C13, C26	Capacitor, 0603, 10 pF, 50 V	AVX 06035A100JAT2A
C8, C12	Capacitor, Case A, 22 $\mu$ F, 6.3 V	AVX TAJA226K006RNJ
C14, C15	Capacitor, 0603, 1 nF, 50 V	AVX 06035A102JAT2A
C16, C17, C18, C19	Capacitor, 0603, 100 pF, 50 V	AVX 06035A101JAT2A
C20, C23	Capacitor, Case A, 1 $\mu$ F, 16 V	AVX TAJA105K016RNJ
C21, C24	Capacitor, 0603, 10 nF, 50 V	AVX 06035C103JAT2A
C22, C25	Capacitor, Case A, 4.7 $\mu$ F, 10 V	AVX TAJA475K010RNJ
D1	LED, green	OSRAM LGR971-Z
D2	Diode, DO41, 1 A, 50 V	Multicomp 1N4001
D3, D5	SD103C, 6.2 V	ON Semiconductor MBR0520LT1G
D4	LED, red	Avago HSMS-C170
J1	120-way connector, 0.6 mm pitch	Hirose FX8-120S-SV(21)
J2	Jack, SMA, SMA_EDGE	Emerson 142-0701-851
J3, J4, J11	Jack, SMA, receptacle straight PCB	Not inserted
J5, J6, J7, J8, J9	Jack, SMA, SMA_EDGE	Not inserted
J10	Jack, SMA, receptacle straight PCB	Pomona 72963
LK1, LK3, LK4	Jumper-2\SIP3, 3-pin link	Harwin M20-9990345 and M7566-05
LK2	Jumper-2	Harwin M20-9990245 and M7566-05
LK5	Jumper-2\SIP3, 3-pin link	Not inserted
GND	Black 4 mm banana socket	Deltron 571-0100-01
VSUPPLY	Red 4 mm banana socket	Deltron 571-0500-01
R1A	Resistor, 0805	Not inserted
R1	Resistor, 0603, 5.6 k $\Omega$	Multicomp MC 0.063 0603 1% 5k6
R2	Resistor, 0603, 9.1 k $\Omega$	Multicomp MC 0.063 0603 1% 9k1
R3	Resistor, 0805, 5.1 k $\Omega$ , $\pm$ 1%, 0.1 W	Multicomp MC 0.1 0805 1% 5K1
R4, R5, R6, R23, R29, R42	Resistor, 0603, 330 $\Omega$	Multicomp MC 0.063W 0603 1% 330R
R7, R8, R9	Resistor, 0603, 18 $\Omega$	Multicomp MC 0.063W 0603 1% 18R
R10, R17	Resistor, 0603, 51 $\Omega$	Multicomp MC 0.063W 0603 1% 51R
R11	Resistor, 0603, 100 $\Omega$	Multicomp MC 0.0625W 0402 1% 100R
R12, R13, R24, R25, R26	Resistor, 0603, 10 k $\Omega$	Multicomp MC 0.063W 0603 1% 10K
R14, R16, R18, R28, R36	Resistor, 0603, 0 $\Omega$	Multicomp MC 0.063W 0603 1% 0R
R15, R22, R27, R32, R33, R37, R46	Resistor, 0603	Not inserted
R19, R20	Resistor, 0603, 330 k $\Omega$ , $\pm$ 1%, 0.063 W	Multicomp MC 0.063W 0603 1% 330K
R21	Resistor, 0603, 4.7 k $\Omega$ , $\pm$ 1%, 0.063 W	Multicomp MC 0.063W 0603 1% 4K7
R30	Resistor, 0402	Not inserted
R31, R34	Resistor, RC31, 0402, 100 k $\Omega$	YAGEO (Phycomp) RC0402JR-07100KL
S1	Switch, PCB, SPDT, 20 V	APEM TL36P0050
T1 to T14	Test point, PCB, red PK_100	Vero 20-313137
U1	<a href="#">ADF4113HV</a> , 16-lead TSSOP	<a href="#">ADF4113HVBRUZ</a>
U3	<a href="#">ADP3300</a> , 6-lead SOT-23	<a href="#">ADP3300ARTZ-5REEL7</a>
U2	<a href="#">ADP3300</a> , 6-lead SOT-23	<a href="#">ADP3300ARTZ-3-RL7</a>
U4	32k I <sup>2</sup> C serial EEPROM, MSOP8	Microchip 24LC32A-I/MS
Y1	1290 MHz to 2260 MHz VCO	Mini-Circuits ROS-2260W+
Y2	25 MHz, SMD, temperature compensated crystal oscillator	Rakon TXO225B

**RELATED LINKS**

<b>Resource</b>	<b>Description</b>
<a href="#">ADF4113HV</a>	Product Page, Fractional-N Frequency Synthesizer
<a href="#">ADP3300</a>	Product Page, High Accuracy anyCAP® 50 mA Low Dropout Linear Regulator
<a href="#">ADSP-BF527</a>	Product Page, Low Power Blackfin Processor with Advanced Peripherals
<a href="#">SDP-S</a>	Product Page, System Demonstration Platform-Serial (SDP-S)
<a href="#">SDP-B</a>	Product Page, System Demonstration Platform-Blackfin (SDP-B)
<a href="#">UG-291</a>	User Guide, SDP-S Controller Board
<a href="#">UG-277</a>	User Guide, SDP-B Controller Board

**NOTES**

**NOTES**

## NOTES

I<sup>2</sup>C refers to a communications protocol originally developed by Philips Semiconductors (now NXP Semiconductors).

**ESD Caution**

**ESD (electrostatic discharge) sensitive device.** Charged devices and circuit boards can discharge without detection. Although this product features patented or proprietary protection circuitry, damage may occur on devices subjected to high energy ESD. Therefore, proper ESD precautions should be taken to avoid performance degradation or loss of functionality.

**Legal Terms and Conditions**

By using the evaluation board discussed herein (together with any tools, components documentation or support materials, the "Evaluation Board"), you are agreeing to be bound by the terms and conditions set forth below ("Agreement") unless you have purchased the Evaluation Board, in which case the Analog Devices Standard Terms and Conditions of Sale shall govern. Do not use the Evaluation Board until you have read and agreed to the Agreement. Your use of the Evaluation Board shall signify your acceptance of the Agreement. This Agreement is made by and between you ("Customer") and Analog Devices, Inc. ("ADI"), with its principal place of business at One Technology Way, Norwood, MA 02062, USA. Subject to the terms and conditions of the Agreement, ADI hereby grants to Customer a free, limited, personal, temporary, non-exclusive, non-sublicensable, non-transferable license to use the Evaluation Board FOR EVALUATION PURPOSES ONLY. Customer understands and agrees that the Evaluation Board is provided for the sole and exclusive purpose referenced above, and agrees not to use the Evaluation Board for any other purpose. Furthermore, the license granted is expressly made subject to the following additional limitations: Customer shall not (i) rent, lease, display, sell, transfer, assign, sublicense, or distribute the Evaluation Board; and (ii) permit any Third Party to access the Evaluation Board. As used herein, the term "Third Party" includes any entity other than ADI, Customer, their employees, affiliates and in-house consultants. The Evaluation Board is NOT sold to Customer; all rights not expressly granted herein, including ownership of the Evaluation Board, are reserved by ADI. CONFIDENTIALITY. This Agreement and the Evaluation Board shall all be considered the confidential and proprietary information of ADI. Customer may not disclose or transfer any portion of the Evaluation Board to any other party for any reason. Upon discontinuation of use of the Evaluation Board or termination of this Agreement, Customer agrees to promptly return the Evaluation Board to ADI. ADDITIONAL RESTRICTIONS. Customer may not disassemble, decompile or reverse engineer chips on the Evaluation Board. Customer shall inform ADI of any occurred damages or any modifications or alterations it makes to the Evaluation Board, including but not limited to soldering or any other activity that affects the material content of the Evaluation Board. Modifications to the Evaluation Board must comply with applicable law, including but not limited to the RoHS Directive. TERMINATION. ADI may terminate this Agreement at any time upon giving written notice to Customer. Customer agrees to return to ADI the Evaluation Board at that time. LIMITATION OF LIABILITY. THE EVALUATION BOARD PROVIDED HEREUNDER IS PROVIDED "AS IS" AND ADI MAKES NO WARRANTIES OR REPRESENTATIONS OF ANY KIND WITH RESPECT TO IT. ADI SPECIFICALLY DISCLAIMS ANY REPRESENTATIONS, ENDORSEMENTS, GUARANTEES, OR WARRANTIES, EXPRESS OR IMPLIED, RELATED TO THE EVALUATION BOARD INCLUDING, BUT NOT LIMITED TO, THE IMPLIED WARRANTY OF MERCHANTABILITY, TITLE, FITNESS FOR A PARTICULAR PURPOSE OR NON-INFRINGEMENT OF INTELLECTUAL PROPERTY RIGHTS. IN NO EVENT WILL ADI AND ITS LICENSORS BE LIABLE FOR ANY INCIDENTAL, SPECIAL, INDIRECT, OR CONSEQUENTIAL DAMAGES RESULTING FROM CUSTOMER'S POSSESSION OR USE OF THE EVALUATION BOARD, INCLUDING BUT NOT LIMITED TO LOST PROFITS, DELAY COSTS, LABOR COSTS OR LOSS OF GOODWILL. ADI'S TOTAL LIABILITY FROM ANY AND ALL CAUSES SHALL BE LIMITED TO THE AMOUNT OF ONE HUNDRED US DOLLARS (\$100.00). EXPORT. Customer agrees that it will not directly or indirectly export the Evaluation Board to another country, and that it will comply with all applicable United States federal laws and regulations relating to exports. GOVERNING LAW. This Agreement shall be governed by and construed in accordance with the substantive laws of the Commonwealth of Massachusetts (excluding conflict of law rules). Any legal action regarding this Agreement will be heard in the state or federal courts having jurisdiction in Suffolk County, Massachusetts, and Customer hereby submits to the personal jurisdiction and venue of such courts. The United Nations Convention on Contracts for the International Sale of Goods shall not apply to this Agreement and is expressly disclaimed.