

PART NUMBER	REVISION	DESCRIPTION	FEED TYPE
2266597-1	E	FINE CRIMP HEIGHT ADJUST	MECHANICAL
2266597-2	F	FINE CRIMP HEIGHT ADJUST	PNEUMATIC
5-2266597-1	E	SEAL STRIPPER CRIMPER TERMINATING UNIT	MECHANICAL
5-2266597-2	F	SEAL STRIPPER CRIMPER TERMINATING UNIT	PNEUMATIC
7-2266597-1	E	MECHANICAL AND CRIMP TOOLING KIT	MECHANICAL
7-2266597-2	F	PNEUMATIC AND CRIMP TOOLING KIT	PNEUMATIC
7-2266597-7	B	CRIMP TOOLING KIT	-

ATLANTIC VERSION TERMINATOR INTERFACE ADAPTER

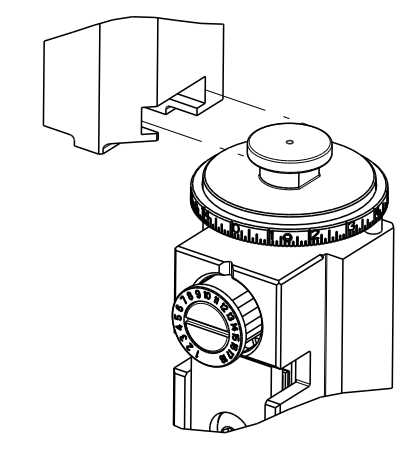

APPLICATOR DATA		
CRIMP	SIZE	TYPE
WIRE	1.90 mm [.075]	F
INSUL	3.20 mm [.126]	F

APPLICATOR INSTRUCTIONS 408-35042

TERMINAL DATA: MOLEX TERMINAL	MOLEX CRIMP SPECIFICATION
TERMINAL NAME: MINI-FIT JR	

WIRE STRIP LENGTH	INSULATION DIAMETER RANGE
3.00-3.50 mm [.118-.138 IN]	∅2.60-3.10 mm [.102-.122 IN]

TERMINAL APPLICATION SPECIFICATION	ATS-639041400 Rev A

TERMINALS APPLIED			
TE TERMINAL	MOLEX TERMINAL	TE TERMINAL	MOLEX TERMINAL
286673-1	39-00-0077	286857-1	39-00-0081
286673-2	39-00-0079	286857-2	39-00-0083
286673-3	39-00-0089	286857-3	39-00-0095
286673-6	39-00-0185	286857-4	39-00-0124
286673-7	39-00-0211	286857-5	39-00-0130
286673-8	39-00-0217	286857-6	39-00-0223
286673-9	39-00-0093	286857-7	44476-311
1-286673-0	39-00-0112	286857-8	39-00-0147
1-286673-1	39-00-0118	286857-9	39-00-0449
1-286673-2	39-00-0141	1-286857-0	39-00-0099
1-286673-9	45750-3211	1-286857-1	40-01-0855
2-286673-0	45750-3111	1-286857-2	98-00-0176
2-286673-1	46018-3541	1-286857-4	44485-3211
2-286673-2	44478-3111	1-286857-6	46012-3111
2-286673-3	44476-3111	1-286857-7	46012-3141
		1-286857-8	46012-3211
		1-286857-9	46012-3241
		2-286857-0	44485-3411
		2-286857-1	44476-3211
		2-286857-2	44478-3211

WIRE SIZE	CRIMP HEIGHT mm [INCH]	CRIMP HEIGHT REFERENCE SETTING
16 AWG OR 1.31mm2	1.19+/-0.05 [.047+/-0.002]	8.5

- 1 RECOMMENDED SPARE PARTS
 - 2 REFER TO SUPPLIED INSTRUCTION SHEET FOR CLEANING, LUBRICATION & STORAGE OF APPLICATOR.
 - 3 APPLY PART NUMBER 1-23419-5 LOCTITE TO THREADS OF ITEM 180. APPLY PART NUMBER 2-23419-6 LOCTITE TO THREADS OF ITEM 242.
 - 4 CRIMP HEIGHT REFERENCE SETTING WAS THE SETTING USED WHEN THE APPLICATOR WAS QUALIFIED AT THE FACTORY. ADJUSTMENT MAY BE NECESSARY WHEN RUNNING APPLICATOR IN THE FIELD.
 - 5 APPLICATOR DESIGNED FOR LARGER INSULATION (∅2.60-3.10mm)
 - 6 TERMINAL LUBRICANT IS RECOMMENDED.
7. UNLESS SPECIFIED OTHERWISE TORQUE VALUES SHALL BE USED PER DOCUMENT, 101-35000.

***WARNING**
 ON INSTALLATION, SET WIRE DISC TO CRIMP HEIGHT REFERENCE SETTING FOR LARGEST WIRE SIZE. CRIMP HEIGHT REFERENCE SETTINGS GREATER THAN THE VALUE SHOWN MAY CAUSE DAMAGE TO THE CRIMP TOOLING, REFER TO THE INSTRUCTION SHEET FOR PROPER SETUP AND ADJUSTMENTS.

ATLANTIC VERSION
 Shown on sheets 1 of 4 & 2 of 4
 (Pacific version shown on sheets 3 of 4 & 4 of 4)

LOC	DIST	REVISIONS					
A	66	P	LTN	DESCRIPTION	DATE	DWN	APVD
		C1		ECR-17-012061	18AUG2017	MZ	JDG
		D		ECR-18-001449	30JAN2018	MZ	KZ
		E		ECR-18-010197	29JUN2018	LG	TE
		F		ECR-21-006510	27JUN2021	TB	RR

-	-	-	1	1	-	-	1803515-3	RAM ASSEMBLY, SF ATLANTIC	293
-	-	-	1	1	-	-	2-1803583-1	APPLICATOR BASIC ASSEMBLY, SF	292
-	1	1	1	1	1	1	2119791-9	DEPRESSOR, WIRE	286
-	1	-	1	-	1	-	2119641-1	FEED CAM, AIR FEED	248
-	1	1	1	1	1	1	2119082-3	CAM, SNAIL, INSULATION ADJUSTMENT	244
-	1	1	1	1	1	1	2079764-1	WASHER, WAVE SPRING, CREST-TO-CREST	243
3	-	1	1	1	1	1	2119083-1	RETAINER, INSULATION DIAL	242
-	1	1	1	1	1	1	7-18023-7	SCR, SKT HD CAP M3 X 4.0	241
-	-	1	-	1	-	1	2119580-1	MECHANICAL FEED ASSEMBLY	239
-	1	-	1	-	1	-	2844940-1	AIR FEED MODULE	238
-	-	-	1	1	-	-	4-1722335-3	STRIPPER, SIDE FEED	182
3	-	-	-	1	1	-	1-5018030-0	NUT, HEX, REG, RoHS, M3.5	181
-	-	-	-	1	1	-	2-1752354-0	STANDOFF, HOLD-DOWN	180
-	-	-	1	1	-	-	993111-1	PIN, SLOTTED SPRING 3.0 X 20.0	177
-	-	-	1	1	-	-	5-22280-0	SPRING, COMPRESSION	176
-	-	-	1	1	-	-	1752353-3	GUIDE PIN, HOLDDOWN	175
-	-	-	1	1	-	-	1901680-2	GUIDE PIN, HOLDDOWN	174
-	REF	REF	REF	REF	REF	REF	994970-2	COUNTER, MAGNETIC	164
6	-	1	1	1	1	1	2119955-1	ASSY, LUBRICATOR, SIDE FEED	113
-	1	1	1	1	1	1	2844908-1	SCREW, LOCKING	99
-	1	1	1	1	1	1	2844907-1	POST, LOCKING	98
-	1	1	1	1	1	1	455888-6	SPACER, CRIMPER	82
-	1	1	1	1	1	1	1803607-2	DOCUMENTATION PACKAGE	71
-	1	1	1	1	1	1	2119791-5	DEPRESSOR, WIRE	70
-	1	1	1	1	1	1	2119740-1	TAG, IDENTIFICATION	67
-	2	2	2	2	2	2	2168078-1	SCREW, DRIVE, RH, RoHS, 2 x .188	66
-	1	1	1	1	1	1	2168083-2	SCR, SKT HD CAP, RoHS, M4 X 8.0	60
-	1	1	1	1	1	1	5-18022-5	SCR, HEX HD CAP, M4 X 6.0	59
-	1	1	1	1	1	1	1338685-1	PAWL, FEED	56
-	4	4	4	4	4	4	2168083-3	SCR, SKT HD CAP, RoHS, M4 X 12.0	54
-	2	2	2	2	2	2	2168083-8	SCR, SKT HD CAP, RoHS, M4 X 16	53
-	1	1	1	1	1	1	5018030-1	NUT, HEX, REG, RoHS, M3	52
-	1	1	1	1	1	1	811242-5	BUMPER, HOLD DOWN	51
-	1	1	1	1	1	1	690753-2	SPACER, TONKER	50
-	1	2	1	2	1	2	18023-9	SCR, SKT HD CAP M4 X 6.0	49
-	-	1	-	1	-	1	2119652-1	FEED CAM, PRE FEED	48
-	-	1	-	1	-	1	2119653-1	FEED CAM, POST FEED	47
-	1	1	-	-	1	1	1803583-9	APPLICATOR BASIC ASSEMBLY, SF	46
-	1	1	-	-	1	1	1803515-1	RAM ASSEMBLY, SF ATLANTIC	44
-	1	1	1	1	1	1	1803602-1	SCR, BHSC, RoHS (M8 X 25)	41
-	1	1	1	1	1	1	1752356-2	SUPPORT, TERMINAL	34
-	2	2	2	2	2	2	2079383-5	SCR, BHSC, RoHS (M4 X 20)	33
-	2	2	2	2	2	2	2-2844962-6	SPACER, CYLINDRICAL, STRIP GUIDE	30
-	1	1	1	1	1	1	2844992-1	ASSEMBLY, STRIP GUIDE	29
-	1	1	1	1	1	1	455888-5	SPACER, CRIMPER	28
-	1	1	1	1	1	1	1320928-2	STRIP GUIDE	24
-	1	1	-	-	1	1	2168083-2	SCR, SKT HD CAP, RoHS, M4 X 8.0	21
-	2	2	1	1	2	2	1-18028-2	WASHER, FLAT, REG M4	20
-	1	1	-	-	1	1	2119533-1	STRIPPER, SIDE FEED	19
1	1	1	1	1	1	1	2119806-1	INSERT, SHEAR	13
-	1	1	1	1	1	1	3-22280-3	SPRING, COMPRESSION	12
-	1	1	1	1	1	1	1-356885-4	STOP, SHEAR	11
1	1	1	1	1	1	1	2119805-1	SHEAR HOLDER, FRONT	10
-	1	1	1	1	1	1	1803095-3	FLOATING SHEAR, FRONT	9
1	2	2	1	1	1	1	2-1803171-1	ANVIL, COMBINATION	8
-	1	1	1	1	1	1	1-240641-0	SPACER	7
-	-	-	-	-	-	-	-	-	6
-	1	1	1	1	1	1	2119757-1	DEPRESSOR, SHEAR	5
-	1	1	1	1	1	1	238011-6	BLOCK, CRIMPER SPACER	4
1	2	2	1	1	1	1	3-1803223-3	CRIMPER, INSULATION F PREMIUM	3
-	-	-	-	-	-	-	-	-	2
1	2	2	1	1	1	1	4-1803224-8	CRIMPER, WIRE	1

ITEM NO	PART NO	DESCRIPTION	ITEM NO
-77	-72	-71	-52
-51	-2	-1	

THIS IS A PRELIMINARY DRAWING. IT IS SUBJECT TO CHANGE WITHOUT NOTICE. ANY DIMENSIONS SHOWN ARE FOR INFORMATION ONLY. DIMENSIONS SHOULD BE CONTACTED FOR THE LATEST REVISION.	DWN: R.O. WILSON 01DEC2014 CHK: K.J. STAKEM 02DEC2014 APVD: T.L. ELBIN 02DEC2014	NAME: Ocean Side Feed Applicator SIZE: A1 CAGE CODE: 00779 DRAWING NO: 2266597 SCALE: 1:2 SHEET: 1 OF 4 REV: F
---	--	--

LOC	DIST	REVISIONS					
A	66	P	LTN	DESCRIPTION	DATE	OWN	APVD
		-		SEE SHEET 1			

FEED TYPE MECHANICAL

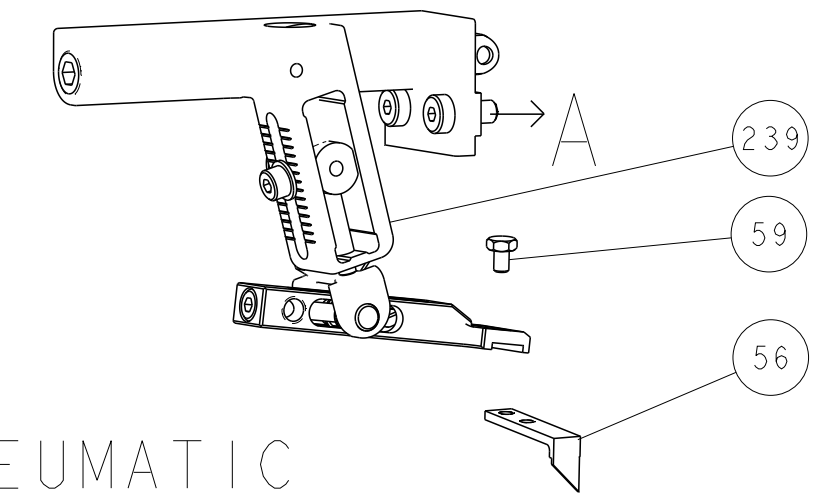

PNEUMATIC

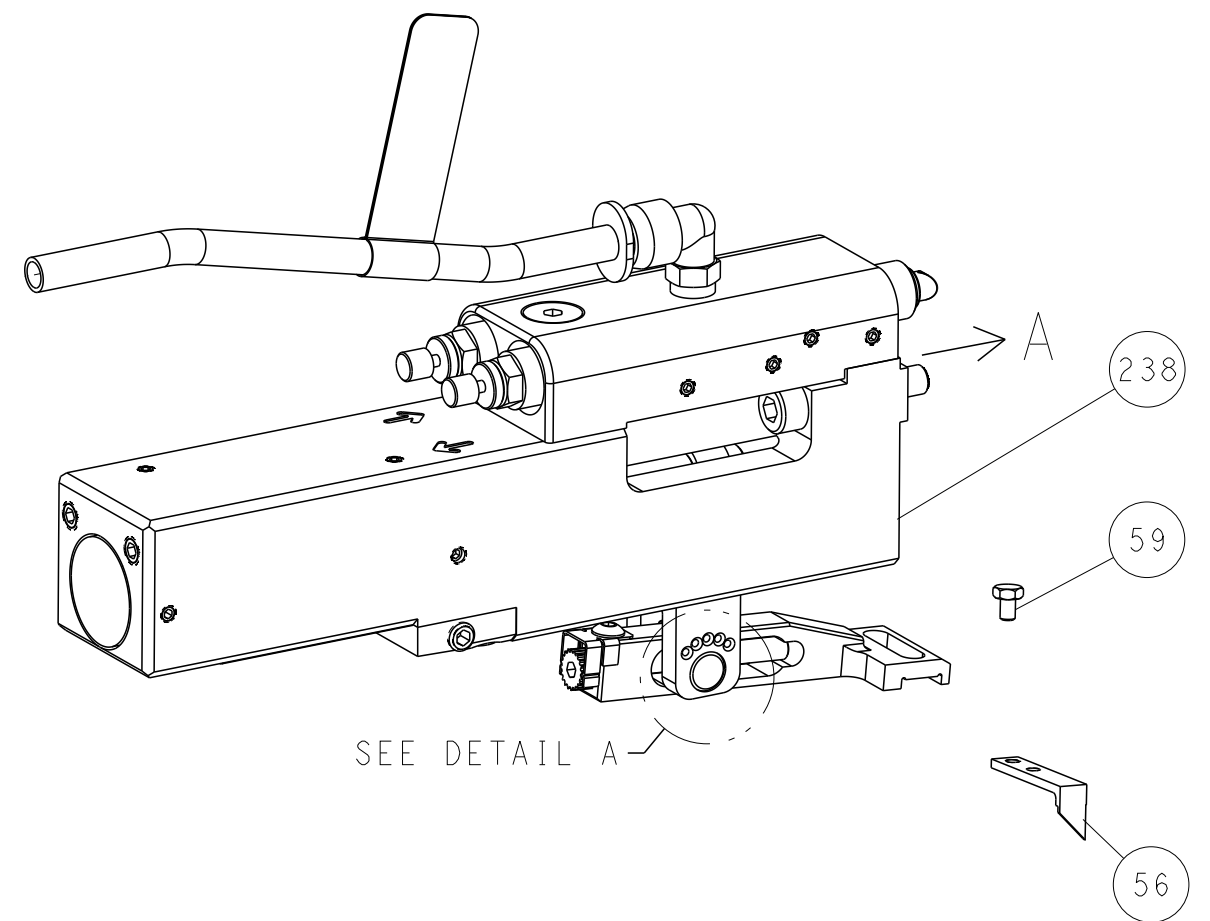

FEED SPRING SETTING POSITION (SHOWN FROM REAR SIDE)

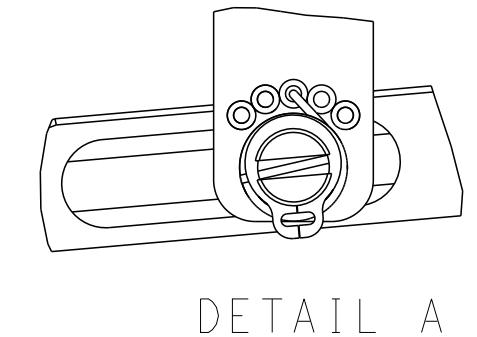

CAM POSITIONS

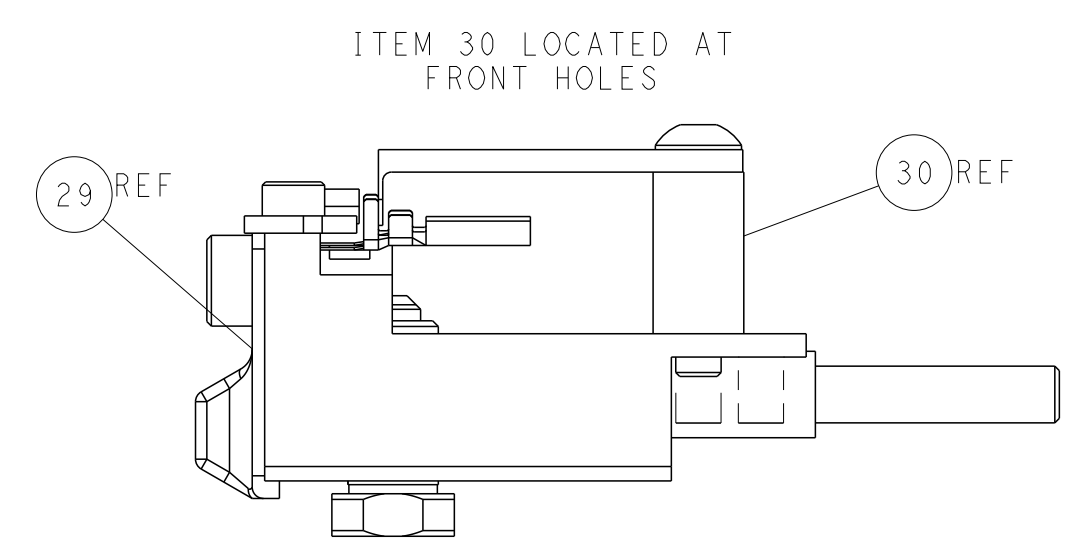
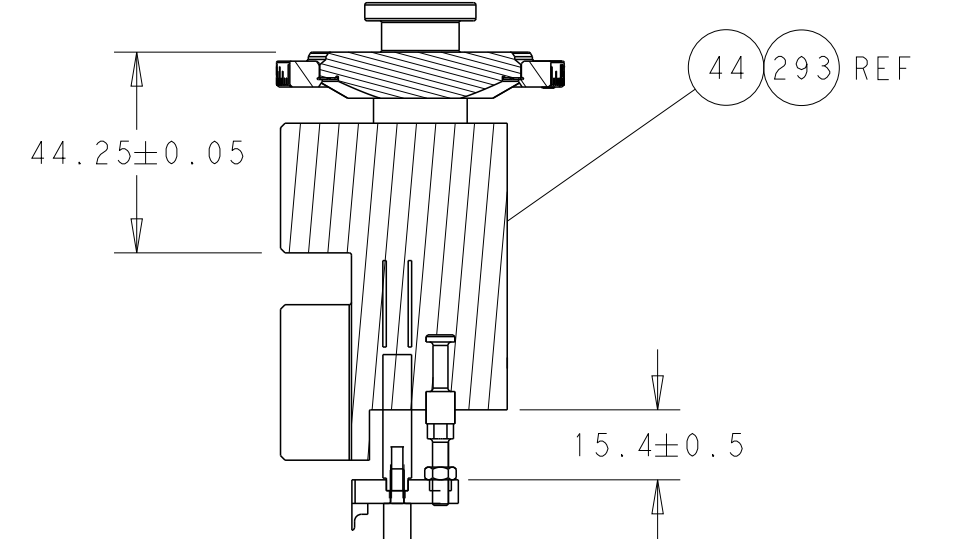
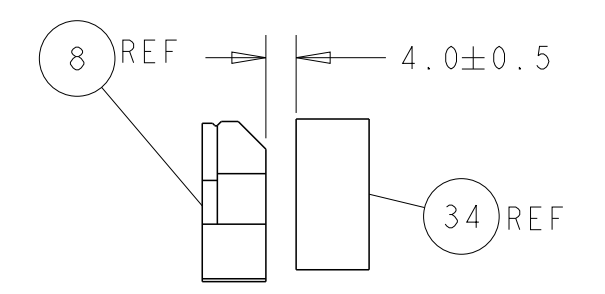
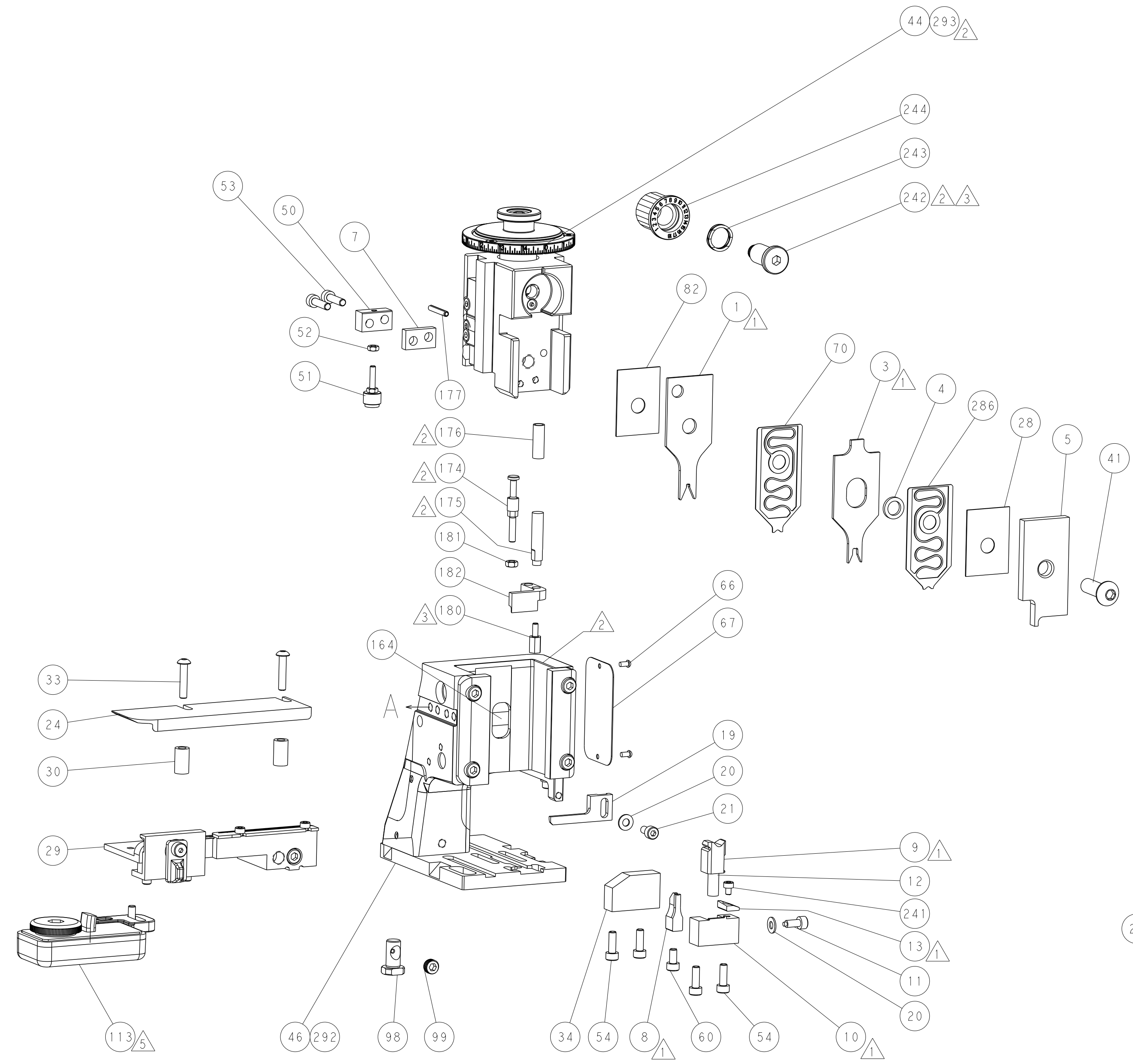
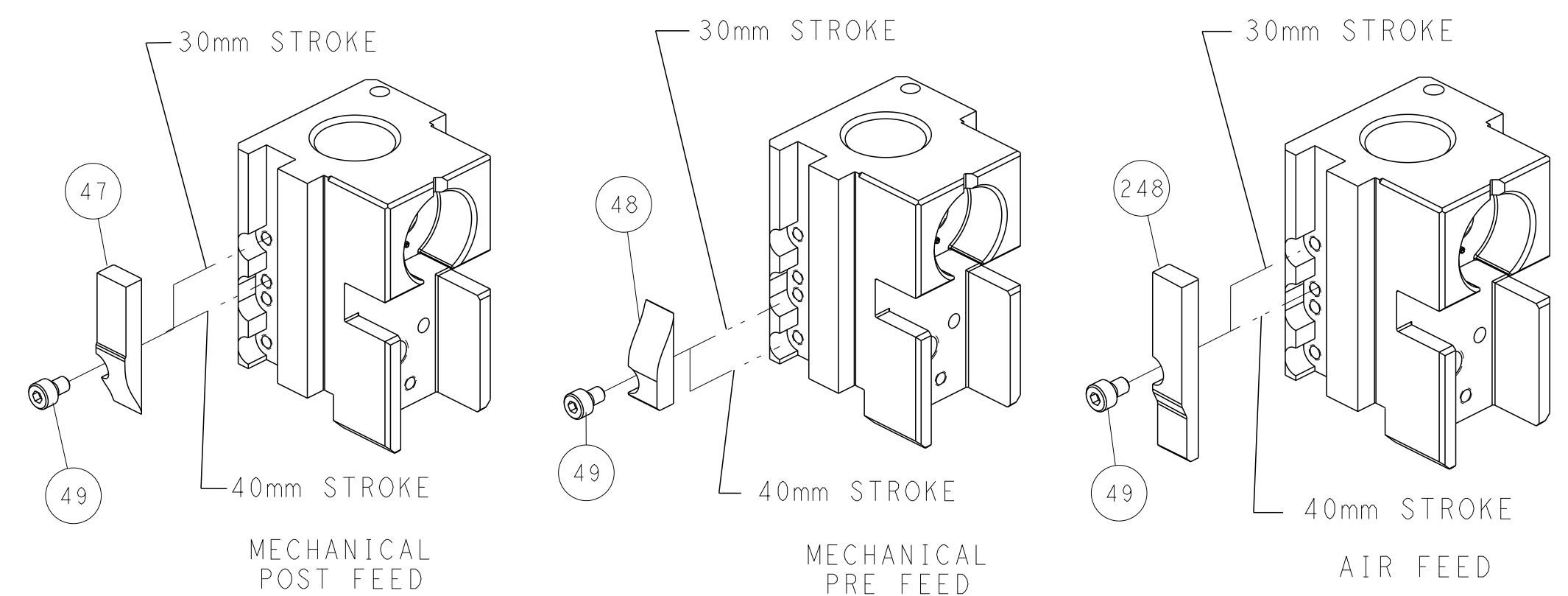

ATLANTIC VERSION
 Shown on sheets 1 of 4 & 2 of 4
 (Pacific version shown on sheets 3 of 4 & 4 of 4)

DIMENSIONS: mm 		TOLERANCES UNLESS OTHERWISE SPECIFIED: 0 PLC ± 1 PLC ± 2 PLC ± 3 PLC ± 4 PLC ± ANGLES ° ±		DWG: R.O. WILSON 01DEC2014 CHK: K.J. STAKEM 02DEC2014 APVD: T.L. ELBIN 02DEC2014 NAME: Ocean Side Feed Applicator SIZE: A1 CAGE CODE: 00779 DRAWING NO: C=2266597 SCALE: 1:2 SHEET: 2 OF 4 REV: F	
MATERIAL:		FINISH:		WEIGHT:	

PART NUMBER	REVISION	DESCRIPTION	FEED TYPE
2-2266597-1	E	FINE CRIMP HEIGHT ADJUST	MECHANICAL
2-2266597-2	F	FINE CRIMP HEIGHT ADJUST	PNEUMATIC
7-2266597-7	B	CRIMP TOOLING KIT	-

PACIFIC VERSION TERMINATOR
 INTERFACE ADAPTER

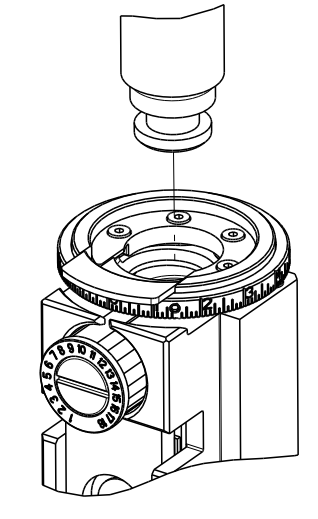

APPLICATOR DATA		
CRIMP	SIZE	TYPE
WIRE	1.90 mm [.075]	F
INSUL	3.20 mm [.126]	F

APPLICATOR INSTRUCTIONS
 408-35042

TERMINAL DATA: MOLEX TERMINAL MOLEX CRIMP SPECIFICATION

TERMINAL NAME: MINI-FIT JR	
WIRE STRIP LENGTH 3.00-3.50 mm [1.18-.138 IN]	INSULATION DIAMETER RANGE Ø2.60-3.10 mm [1.02-.122 IN]
TERMINAL APPLICATION SPECIFICATION ATS-639041400 Rev A	

TERMINALS APPLIED

TE TERMINAL	MOLEX TERMINAL	TE TERMINAL	MOLEX TERMINAL
286673-1	39-00-0077	286857-1	39-00-0081
286673-2	39-00-0079	286857-2	39-00-0083
286673-3	39-00-0089	286857-3	39-00-0095
286673-6	39-00-0185	286857-4	39-00-0124
286673-7	39-00-0211	286857-5	39-00-0130
286673-8	39-00-0217	286857-6	39-00-0223
286673-9	39-00-0093	286857-7	44476-311
1-286673-0	39-00-0112	286857-8	39-00-0147
1-286673-1	39-00-0118	286857-9	39-00-0449
1-286673-2	39-00-0141	1-286857-0	39-00-0099
1-286673-9	45750-3211	1-286857-1	40-01-0855
2-286673-0	45750-3111	1-286857-2	98-00-0176
2-286673-1	46018-3541	1-286857-4	44485-3211
2-286673-2	44478-3111	1-286857-6	46012-3111
2-286673-3	44476-3111	1-286857-7	46012-3141
		1-286857-8	46012-3211
		1-286857-9	46012-3241
		2-286857-0	44485-3411
		2-286857-1	44476-3211
		2-286857-2	44478-3211

WIRE SIZE	CRIMP HEIGHT mm [INCH]	CRIMP HEIGHT REFERENCE SETTING
16 AWG OR 1.31mm ²	1.19+/-0.05 [1.047+/-0.021]	8.5

- 1. RECOMMENDED SPARE PARTS
- 2. REFER TO SUPPLIED INSTRUCTION SHEET FOR CLEANING, LUBRICATION & STORAGE OF APPLICATOR.
- 3. APPLY PART NUMBER 2-23419-6 LOCTITE TO THREADS OF ITEM 242.
- 4. CRIMP HEIGHT REFERENCE SETTING WAS THE SETTING USED WHEN THE APPLICATOR WAS QUALIFIED AT THE FACTORY. ADJUSTMENT MAY BE NECESSARY WHEN RUNNING APPLICATOR IN THE FIELD.
- 5. APPLICATOR DESIGNED FOR LARGER INSULATION (Ø2.60-3.10mm)
- 6. TERMINAL LUBRICANT IS RECOMMENDED.
- 7. UNLESS SPECIFIED OTHERWISE TORQUE VALUES SHALL BE USED PER DOCUMENT, 101-35000.

***WARNING**
 ON INSTALLATION, SET WIRE DISC TO CRIMP HEIGHT REFERENCE SETTING FOR LARGEST WIRE SIZE. CRIMP HEIGHT REFERENCE SETTINGS GREATER THAN THE VALUE SHOWN MAY CAUSE DAMAGE TO THE CRIMP TOOLING, REFER TO THE INSTRUCTION SHEET FOR PROPER SETUP AND ADJUSTMENTS.

PACIFIC VERSION
 Shown on sheets 3 of 4 & 4 of 4
 (Atlantic version shown on sheets 1 of 4 & 2 of 4)

LOC	DIST	REV	DATE	BY	CHKD	APVD
A	66					

REV	DATE	BY	CHKD	APVD	DESCRIPTION	ITEM NO
-	1	1			2119791-9 DEPRESSOR, WIRE	286
-	1	1			2119082-3 CAM, SNAIL, INSULATION ADJUSTMENT	244
-	1	1			2079764-1 WASHER, WAVE SPRING, CREST-TO-CREST	243
-	1	1			2119083-1 RETAINER, INSULATION DIAL	242
-	1	1			7-18023-7 SCR, SKT HD CAP M3 X 4.0	241
-	-	1			2119580-1 MECHANICAL FEED ASSEMBLY	239
-	1	-			2844940-1 AIR FEED MODULE	238
-	REF	REF			994970-2 COUNTER, MAGNETIC	164
-	1	-			2119641-2 FEED CAM, AIR FEED	151
-	1	1			2168083-8 SCR, SKT HD CAP, RoHS, M4 X 16	144
-	4	4			2168083-9 SCR, SKT HD CAP, RoHS, M4 X 20	143
-	-	1			2119653-2 FEED CAM, POST FEED	142
-	1	1			1-1803583-0 APPLICATOR BASIC ASSEMBLY, SF	141
-	1	1			1803516-1 RAM ASSEMBLY, SF PACIFIC	140
-	1	1			2119955-1 ASSY, LUBRICATOR, SIDE FEED	113
-	1	1			2844908-1 SCREW, LOCKING	99
-	1	1			2844907-1 POST, LOCKING	98
-	1	1			455888-6 SPACER, CRIMPER	82
-	1	1			1803607-2 DOCUMENTATION PACKAGE	71
-	1	1			2119791-5 DEPRESSOR, WIRE	70
-	1	1			2119740-1 TAG IDENTIFICATION	67
-	2	2			2168078-1 SCREW, DRIVE, RH, RoHS, 2 x .188	66
-	1	1			5-18022-5 SCR, HEX HD CAP, M4 X 6.0	59
-	1	1			1338685-1 PAWL, FEED	56
-	2	2			2168083-8 SCR, SKT HD CAP, RoHS, M4 X 16	53
-	1	1			5018030-1 NUT, HEX, REG, RoHS, M3	52
-	1	1			811242-5 BUMPER, HOLD DOWN	51
-	1	1			690753-2 SPACER, TONKER	50
-	1	2			18023-9 SCR, SKT HD CAP M4 X 6.0	49
-	-	1			2119652-1 FEED CAM, PRE FEED	48
-	1	1			1803602-1 SCR, BHSC, RoHS (M8 X 25)	41
-	1	1			1752356-2 SUPPORT, TERMINAL	34
-	2	2			2079383-5 SCR, BHSC, RoHS (M4 X 20)	33
-	2	2			2-2844962-6 SPACER, CYLINDRICAL, STRIP GUIDE	30
-	1	1			2844992-1 ASSEMBLY, STRIP GUIDE	29
-	1	1			455888-5 SPACER, CRIMPER	28
-	1	1			1320928-2 STRIP GUIDE	24
-	1	1			2168083-2 SCR, SKT HD CAP, RoHS, M4 X 8.0	21
-	2	2			1-18028-2 WASHER, FLAT, REG M4	20
-	1	1			2119533-1 STRIPPER, SIDE FEED	19
-	1	1			2119806-1 INSERT, SHEAR	13
-	1	1			3-22280-3 SPRING, COMPRESSION	12
-	1	1			1-356885-4 STOP, SHEAR	11
-	1	1			2119805-1 SHEAR HOLDER, FRONT	10
-	1	1			1803095-3 FLOATING SHEAR, FRONT	9
-	1	1			2-1803171-1 ANVIL, COMBINATION	8
-	1	1			1-240641-0 SPACER	7
-	-	-			-	6
-	1	1			2119757-1 DEPRESSOR, SHEAR	5
-	1	1			238011-6 BLOCK, CRIMPER SPACER	4
-	1	1			3-1803223-3 CRIMPER, INSULATION F PREMIUM	3
-	-	-			-	2
-	1	1			4-1803224-8 CRIMPER, WIRE	1

DIMENSIONS: mm 		TOLERANCES UNLESS OTHERWISE SPECIFIED: 0 PLC ± 1 PLC ± 2 PLC ± 3 PLC ± 4 PLC ± ANGLES ± FINISH		DWG: R.O. WILSON 01DEC2014 CHK: K.J. STAKEM 02DEC2014 APVD: T.L. ELBIN 02DEC2014 PRODUCT SPEC APPLICATION SPEC		NAME: Ocean Side Feed Applicator SIZE: A1 CAGE CODE: 00779 DRAWING NO: C=2266597 RESTRICTED TO: F	
MATERIAL: -		WEIGHT: -		SCALE: 1:2		SHEET 3 OF 4	

LOC		DIST		REVISIONS			
A	66	P	LTM	DESCRIPTION	DATE	OWN	APVD
-	-	-	-	SEE SHEET 1	-	-	-

FEED TYPE MECHANICAL

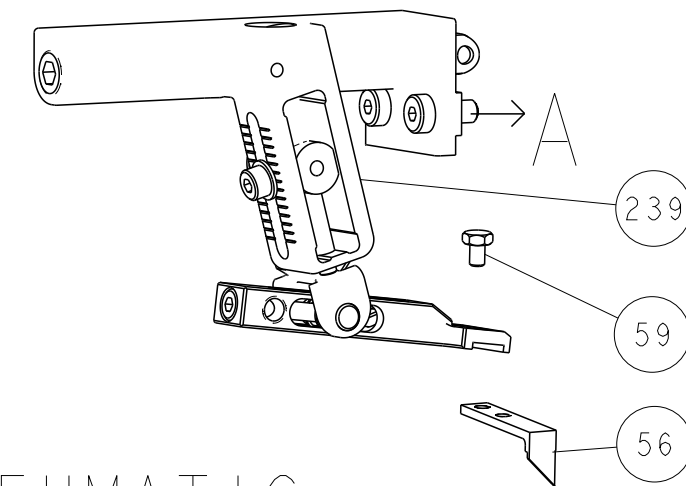

PNEUMATIC

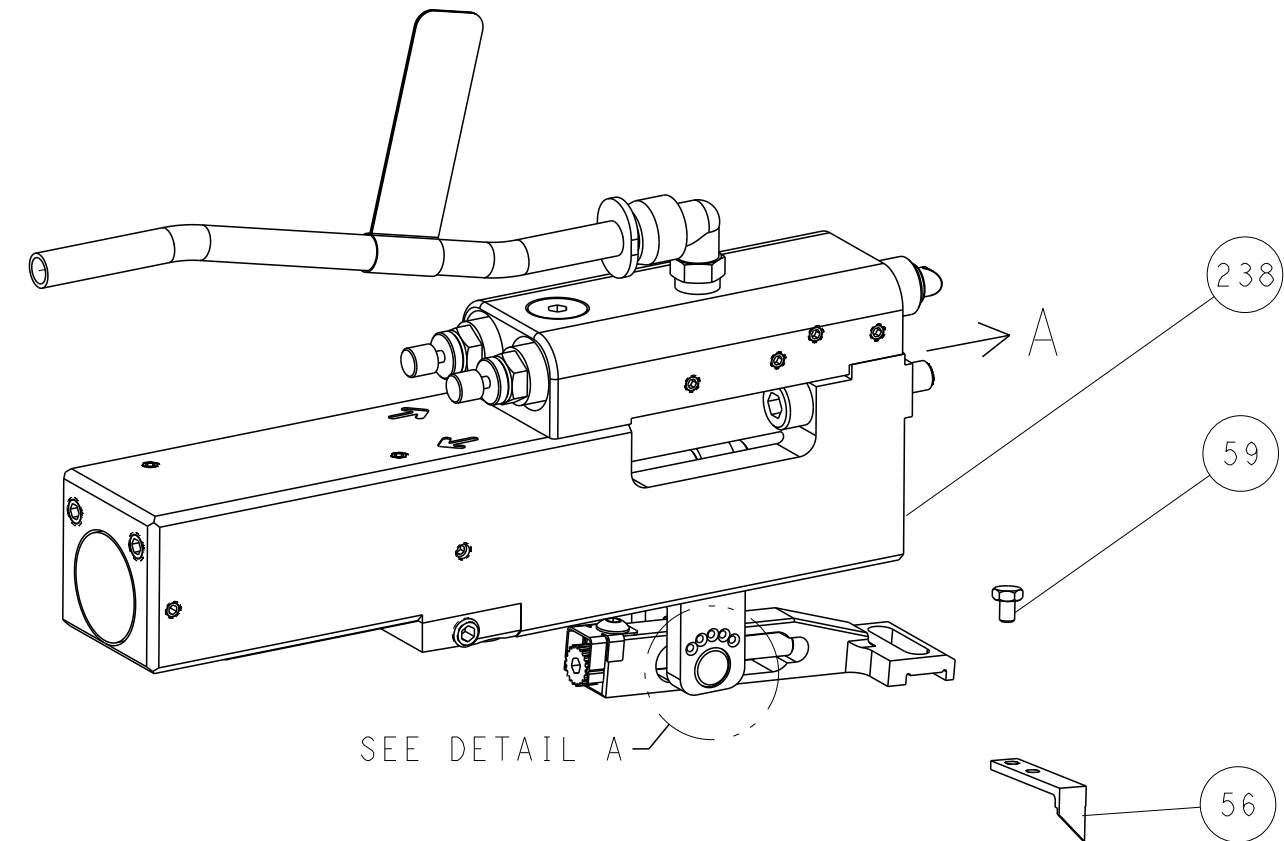

FEED SPRING SETTING POSITION (SHOWN FROM REAR SIDE)

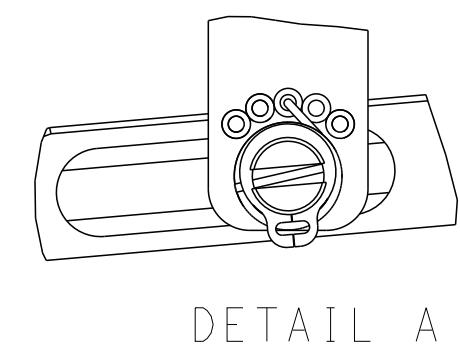

DETAIL A

CAM POSITIONS

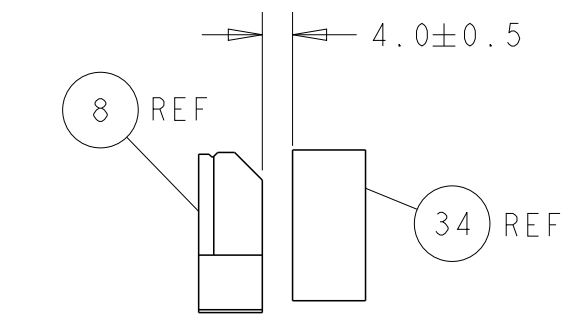
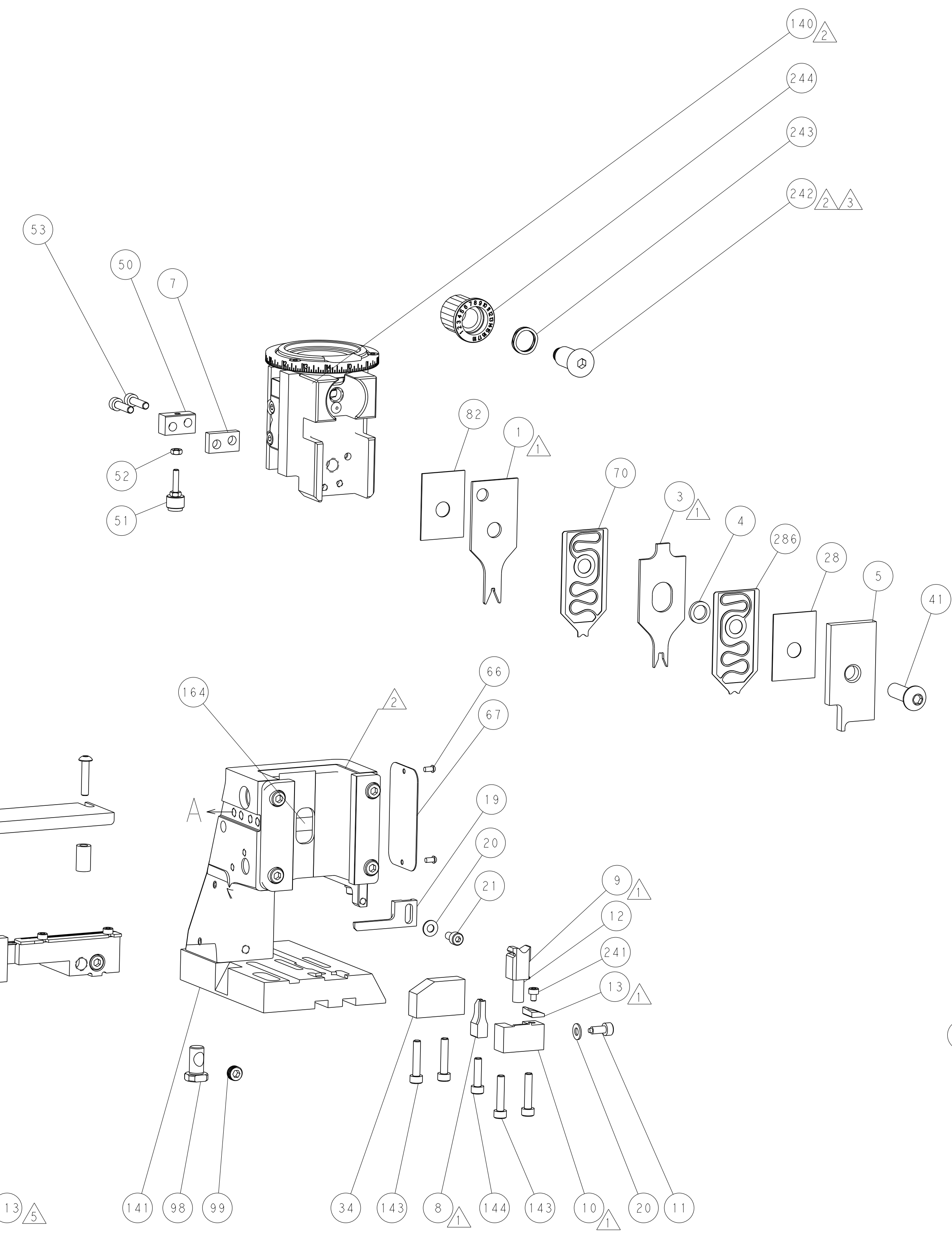
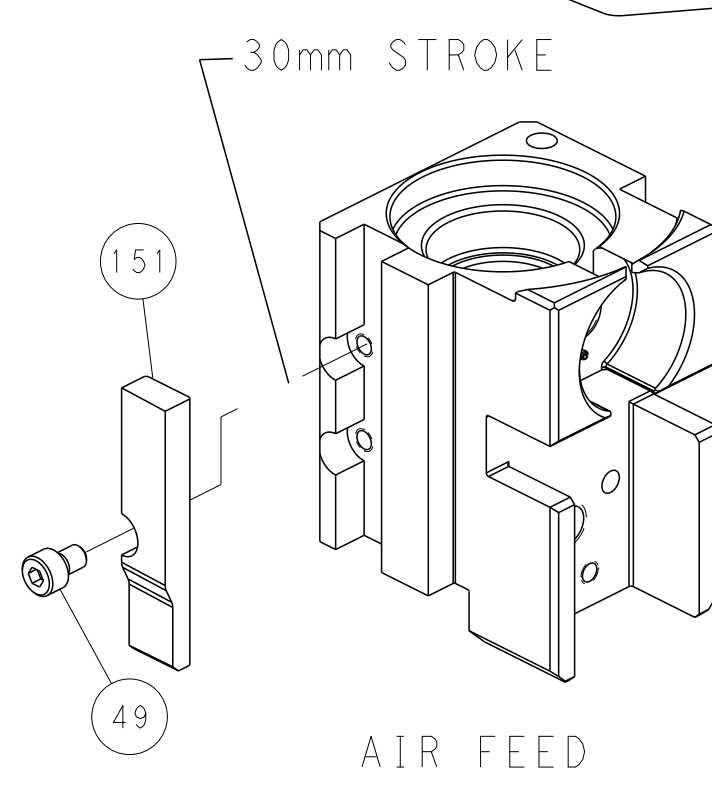
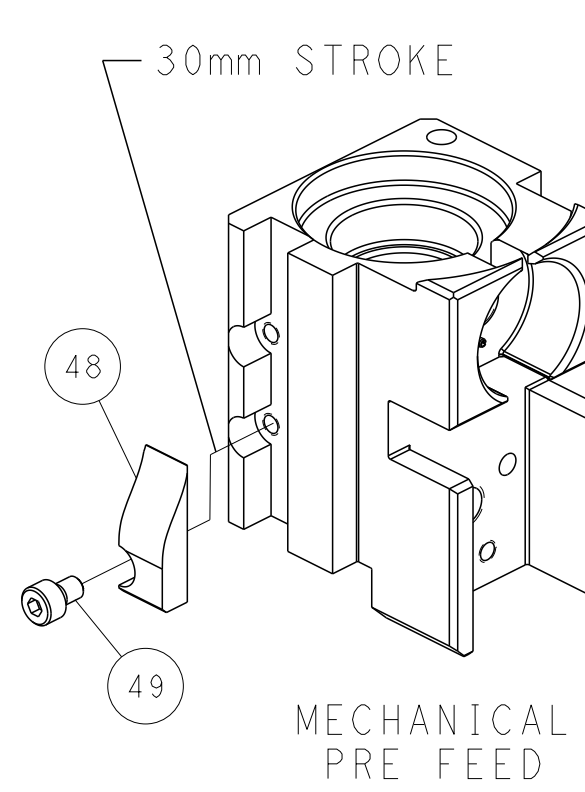
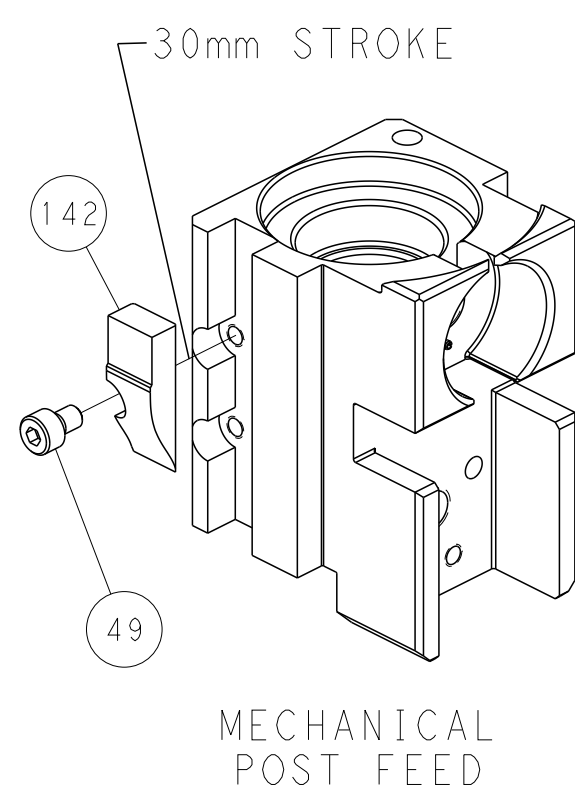

TERMINAL SUPPORT LOCATION

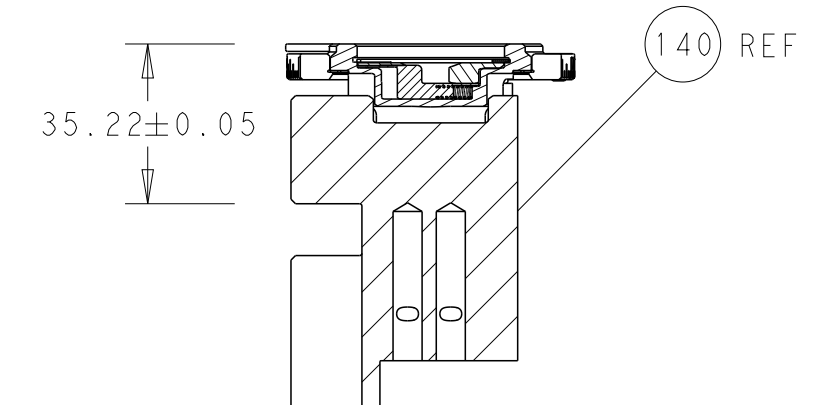

RAM SET-UP

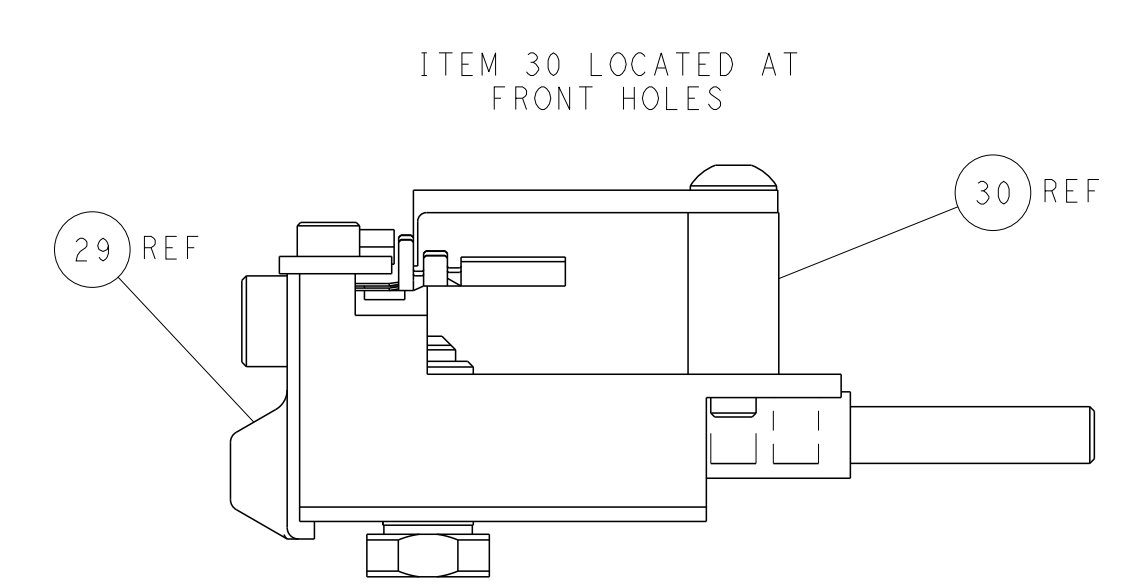

FEED TRACK POSITION GUIDE BY INSULATION BARREL

PACIFIC VERSION
 Shown on sheets 3 of 4 & 4 of 4
 (Atlantic version shown on sheets 1 of 4 & 2 of 4)

DIMENSIONS:		TOLERANCES UNLESS OTHERWISE SPECIFIED:		DWG: R.O. WILSON 01DEC2014		TE Connectivity	
mm	0 PLC ±	1 PLC ±	2 PLC ±	3 PLC ±	4 PLC ±	5 PLC ±	Harrisburg, PA 17105-3608
ANGLES	FINISH	MATERIAL		CHK: K.J. STAKEM	NAME: T.L. ELBIN	Ocean Side Feed Applicator	
MATERIAL		FINISH		APVD: T.L. ELBIN 02DEC2014	PRODUCT SPEC	RESTRICTED TO	
MATERIAL		FINISH		APPLICATION SPEC	SIZE	CAGE CODE	DRAWING NO
MATERIAL		FINISH		WEIGHT	A1	00779	2266597
MATERIAL		FINISH		Customer Accessible Production Drawing	SCALE	SHEET	OF
MATERIAL		FINISH		SCALE: 1:2	SHEET: 4	OF: 4	REV: F