

MAX6575L/H

SOT Temperature Sensor with Multidrop Single-Wire Digital Interface

General Description

The MAX6575L/H is a low-cost, low-current temperature sensor with a single-wire digital interface. It features accuracy of $\pm 3^{\circ}\text{C}$ at $+25^{\circ}\text{C}$, $\pm 4.5^{\circ}\text{C}$ at $+85^{\circ}\text{C}$, and $\pm 5^{\circ}\text{C}$ at $+125^{\circ}\text{C}$. The MAX6575L/H is a monostable, externally triggered temperature sensor that allows a microprocessor (μP) to interface with up to eight temperature sensors using a single control line. Temperatures are sensed by measuring the time delay between the falling edge of the external triggering pulse and the falling edge of the subsequent pulse delays reported from the devices. Different sensors on the same I/O line use different timeout multipliers to avoid overlapping signals.

The MAX6575L/H features eight different timeout multipliers; these are selectable by using the two time-select pins on each device and choosing the “L” or “H” version. The “L” version provides four delay ranges less than 50ms. The “H” version provides four delay ranges greater than 50ms. The MAX6575L/H is available in a space-saving 6-pin SOT23 package.

Applications

- Critical μP and μC Temperature Monitoring
- Portable Battery-Powered Equipment
- Cell Phones
- Battery Packs
- Hard Drives/Tape Drives
- Networking and Telecom Equipment
- Medical Equipment

Typical Operating Circuit

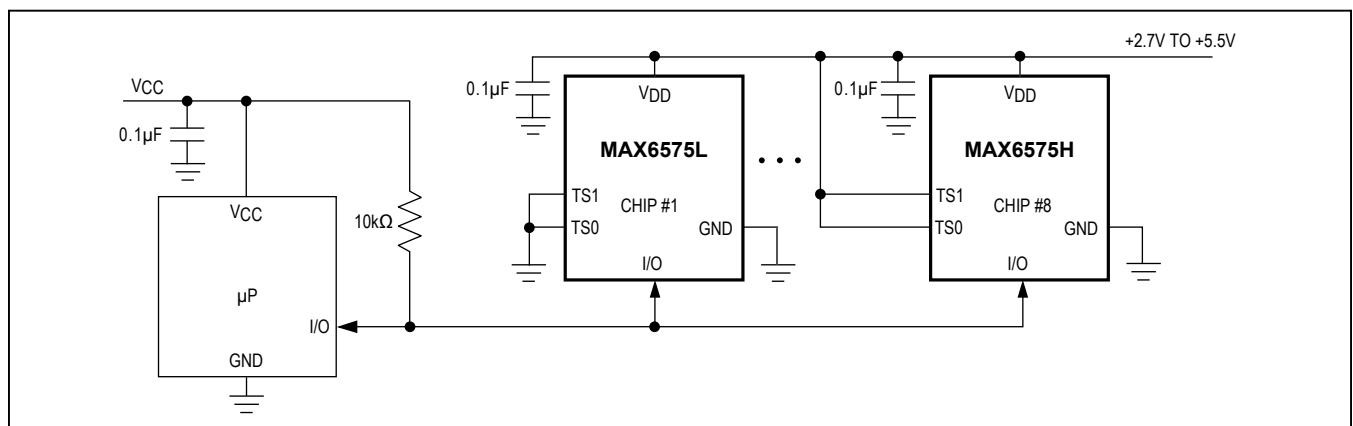

Features

- Simple Single-Wire Interface to μP or μC
- Multidrop up to Eight Sensors on One Wire
- $\pm 0.8^{\circ}\text{C}$ Accuracy at $+25^{\circ}\text{C}$ ($\pm 3^{\circ}\text{C}$ max)
- Operates from $+2.7\text{V}$ to $+5.5\text{V}$ Supply Voltage
- Low 150 μA (typ) Supply Current
- Standard Operating Temperature Range -40°C to $+125^{\circ}\text{C}$
- Small 6-Pin SOT23 Package

Ordering Information

PART	TEMP.RANGE	PIN-PACKAGE	SOT TOP MARK
MAX6575LZUT	-40°C to $+125^{\circ}\text{C}$	6 SOT23	AABG
MAX6575HZUT	-40°C to $+125^{\circ}\text{C}$	6 SOT23	AABH

Selector Guide

PART	TIMEOUT MULTIPLIERS ($\mu\text{s}/^{\circ}\text{K}$)
MAX6575L	5, 20, 40, 80
MAX6575H	160, 320, 480, 640

Pin Configuration appears at end of data sheet.

Absolute Maximum Ratings

Terminal Voltage (with respect to GND)	Continuous Power Dissipation ($T_A = +70^\circ\text{C}$)
V_{DD}-0.3V to +6V	6-Pin SOT23 (derate 7.10mW/°C above +70°C).....571mW
TS1, TS0.....-0.3V to ($V_{DD} + 0.3\text{V}$)	Operating Temperature Range-40°C to +125°C
I/O.....-0.3V to +6V	Storage Temperature Range-65°C to +150°C
Input/Output Current, All Pins.....±20mA	Lead Temperature (soldering, 10s)+300°C

Stresses beyond those listed under "Absolute Maximum Ratings" may cause permanent damage to the device. These are stress ratings only, and functional operation of the device at these or any other conditions beyond those indicated in the operational sections of the specifications is not implied. Exposure to absolute maximum rating conditions for extended periods may affect device reliability.

Electrical Characteristics

($V_{DD} = +2.7\text{V}$ to +5.5V, $T_A = -40^\circ\text{C}$ to +125°C, unless otherwise noted. Typical values are specified at $T_A = +25^\circ\text{C}$ and $V_{DD} = +5\text{V}$, unless otherwise noted.)

PARAMETER	SYMBOL	CONDITIONS	MIN	TYP	MAX	UNITS
V_{DD} Range	V_{DD}		2.7		5.5	V
Supply Current	I_{DD}	$V_{DD} = 5.5\text{V}$ $T_A = -40^\circ\text{C}$ to +85°C $T_A = -40^\circ\text{C}$ to +125°C		150	250 400	µA
Temperature Sensor Error (Note 1)		$T_A = -20^\circ\text{C}$	-7.5	±1.1	+7.5	°C
		$T_A = 0^\circ\text{C}$	-5.5	±0.9	+5.5	
		$T_A = +25^\circ\text{C}$	-3.0	±0.8	+3.0	
		$T_A = +85^\circ\text{C}$	-4.5	±0.5	+4.5	
		$T_A = +125^\circ\text{C}$	-5.0	±0.5	+5.0	
Output Pulse Delay	t_{D1}	MAX6575L, T (temp) in °K, Figure 1	$V_{TS1} = \text{GND}, V_{TS0} = \text{GND}$	5T		µs
	t_{D2}		$V_{TS1} = \text{GND}, V_{TS0} = V_{DD}$	20T		
	t_{D3}		$V_{TS1} = V_{DD}, V_{TS0} = \text{GND}$	40T		
	t_{D4}		$V_{TS1} = V_{DD}, V_{TS0} = V_{DD}$	80T		
	t_{D5}	MAX6575H, T (temp) in °K, Figure 1	$V_{TS1} = \text{GND}, V_{TS0} = \text{GND}$	160T		
	t_{D6}		$V_{TS1} = \text{GND}, V_{TS0} = V_{DD}$	320T		
	t_{D7}		$V_{TS1} = V_{DD}, V_{TS0} = \text{GND}$	480T		
	t_{D8}		$V_{TS1} = V_{DD}, V_{TS0} = V_{DD}$	640T		
Output Pulse Low Time	t_{L1-8}	Figure 1		5T		µs
Reset Pulse Width (Note 2)	t_{RESET}	Figure 1	4.6		16.0	ms
Setup Time	t_{SETUP}	Figure 1		10		µs
Start Pulse (Note 3)	t_{START}	Figure 1, $T_A = +25^\circ\text{C}$	2.5			µs
Delay Time from Trigger to Ready (Note 4)	t_{READY}	Figure 1			520	ms
Glitch Immunity on I/O Input				500		ns
Time-Select Pin Logic Levels	V_{IL}				0.8	V
	V_{IH}		2.3			
I/O Output Voltage Low	V_{OL}	$V_{DD} > 4.5\text{V}, I_{\text{SINK}} = 3.2\text{mA}$			0.4	V
		$V_{DD} > 2.7\text{V}, I_{\text{SINK}} = 1.2\text{mA}$			0.3	
I/O Input Voltage Low	V_{IL}				0.8	V
I/O Input Voltage High	V_{IH}		2.3			V

Note 1: See Temperature Accuracy histograms in *Typical Operating Characteristics*.

Note 2: Guaranteed by design. Not production tested.

Note 3: Limit maximum start pulse at 1ms to avoid timing overlap.

Note 4: If no reset pulse is applied.

Typical Operating Characteristics

(V_{DD} = +5V, T_A = +25°C, unless otherwise noted.)

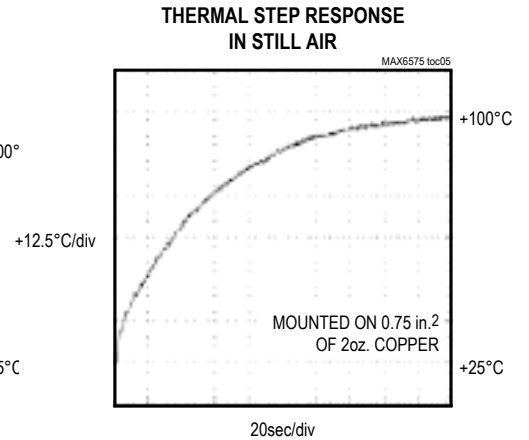
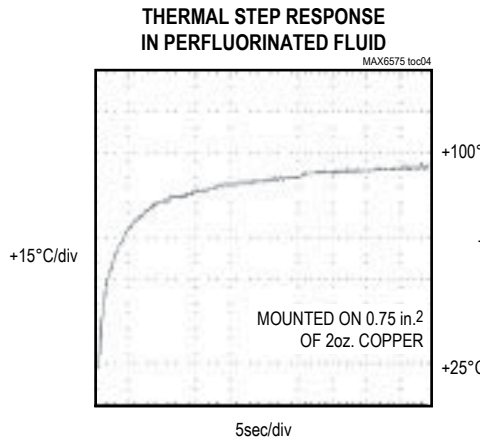
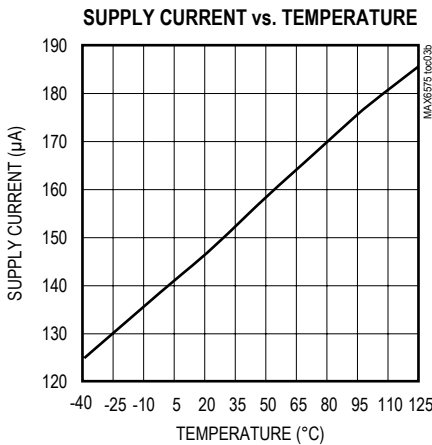
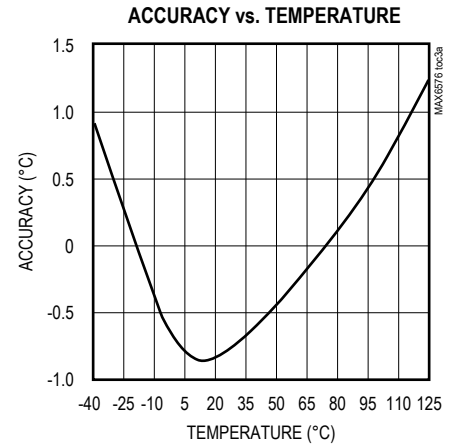
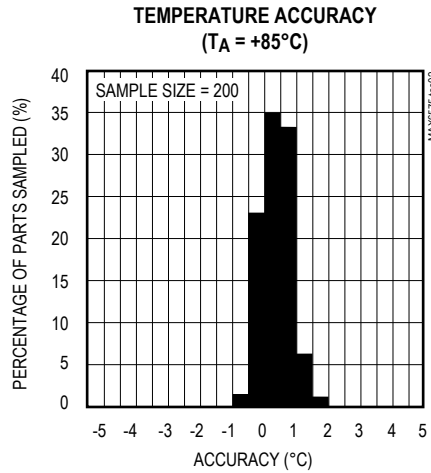
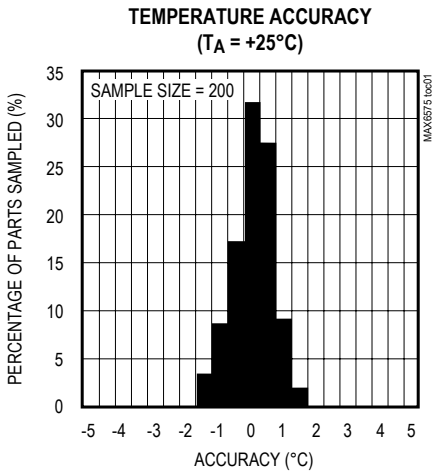

Pin Configuration

PIN	NAME	FUNCTION
1	V _{DD}	Positive Supply Voltage
2	GND	Ground
3	N.C.	No Connect. Connect pin to GND or leave open.
4, 5	TS0, TS1	Time-Select Pins. Set the time delay factor by connecting TS1 and TS0 to either V _{DD} or GND. See Table 1.
6	I/O	Bidirectional Interface Pin. A time delay between when the part is initiated externally by pulling I/O low and when the part subsequently pulls I/O low, is proportional to absolute temperature (°K).

Detailed Description

The MAX6575L/H low-cost, low-current (150µA typ) temperature sensor is ideal for interfacing with microcontrollers or microprocessors. The MAX6575L/H is a monostable, externally triggered temperature sensor that uses a Temp→Delay conversion to communicate with a µP over a single I/O line. Time-select pins (TS1, TS0) permit the internal temperature-controlled oscillator (TCO) to be scaled by four preset timeout multipliers, allowing eight separate temperature sensors to share one I/O line. Different sensors on the same I/O line will use different timeout multipliers to avoid overlapping signals.

Operating the MAX6575L/H

Figure 1 illustrates the timing for the MAX6575L/H. When the device is powered up, it assumes a ready state where it awaits an external trigger at the I/O pin. The I/O pin of the MAX6575L/H has an open-drain output structure that requires a pullup resistor to maintain the proper logic levels. Once the I/O pin is pulled low and then released, control of the I/O pin is transferred to the MAX6575L/H. The temperature conversion begins on the falling edge of the externally triggered pulse. The I/O line is pulled low at a later time. That time is determined by the device temperature and the Time Select pins (TS1, TS0). The I/O line remains low for 5Tµs, where T is the temperature in degrees Kelvin. The temperature of the device is represented by the edgeto-edge delay of the externally triggered pulse and the falling edge of the subsequent pulse originating from the device. The device can be manually reset by pulling the I/O line low for more than tRESET (16ms max). The device will automatically reset after a

Table 1. Time-Select Pin Configuration

TIME-SELECT PINS		TIMEOUT MULTIPLIERS (µs/°K)	
TS1	TS0	MAX6575L	MAX6575H
GND	GND	5	160
GND	VDD	20	320
VDD	GND	40	480
VDD	VDD	80	640

maximum delay of 520ms, at which point it will again be in a ready state awaiting a start pulse.

Definition of Terms:

- tRESET: Time I/O must be externally pulled low to guarantee the MAX6575L/H is in a ready state awaiting external trigger. (Part will assume a ready state after 520ms without a reset pulse.)
- tSETUP: Time I/O must be high prior to a start pulse.
- tSTART: Trigger pulse which starts the on-chip timing sequence on its falling edge.
- tDx: Timing delay between the falling edge of the start pulse and the falling edge initiated by CHIP#x.
- tLx: I/O pulse low time (5Tµs).
- tREADY: Time after falling edge of start pulse when the MAX6575L/H will reset itself and await the next external trigger.

The temperature, in degrees Celsius, may be calculated as follows:

$$T(^{\circ}\text{C}) = [t_{Dx}(\mu\text{s}) / \text{timeout multiplier}(\mu\text{s}/^{\circ}\text{K})] - 273.15^{\circ}\text{K}$$

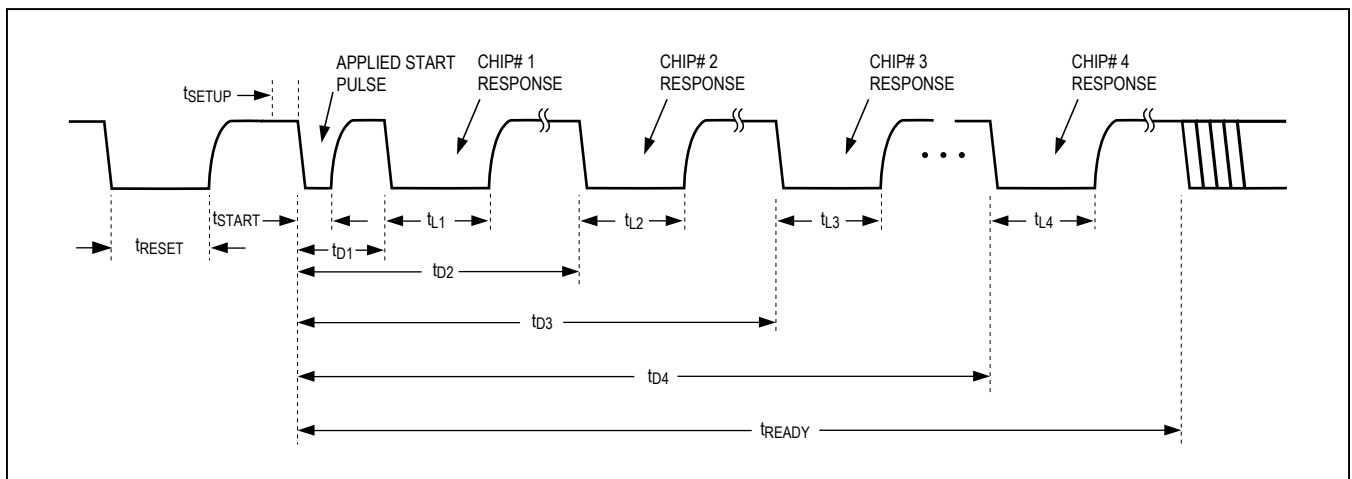

Figure 1. Timing Diagram

Table 2. Allowable Temperature Differential (°C)

TIMEOUT MULTIPLIER	MAX6575L				MAX6575H			
	5	20	40	80	160	320	480	640
5		>165	>165	>165	>165	>165	>165	>165
20			95.5	>165	>165	>165	>165	>165
40				132.0	>165	>165	>165	>165
80					153.5	>165	>165	>165
160						>165	>165	>165
320							70.2	>165
480								37.9
640								

Table 3. Typical Peak Noise Amplitude

PARAMETER	MAX6575L				MAX6575H			
Timeout Multiplier	5	20	40	80	160	320	480	640
Noise Amplitude (°C)	±0.33	±0.15	±0.15	±0.098	±0.091	±0.063	±0.043	±0.037

Time-Select Pins (TS1, TS0)

Table 1 shows the configuration of the Time-select pins for the MAX6575L/H. Each device allows four selectable timeout multipliers intended to prevent overlapping when multiple devices are used on the same I/O line. Tie TS1 and TS0 to either GND or V_{DD} to select the desired temperature multiplier.

To monitor several chips on the same I/O line, different timeout multipliers should be selected using the TS1 and TS0 pins. The timeout periods are then scaled so that the response times will not overlap (see *Timeout Selection*).

Applications Information

Timeout Selection

Under extreme temperature conditions, it is possible for an overlap to occur between the timeout delays of different sensors in a multidrop configuration. This overlap can occur only if the temperature differential recorded between two devices is very large. Timeout overlaps can be avoided in multidrop configurations by selecting the appropriate timeout multipliers. Table 2 illustrates the allowable temperature differential between devices when the maximum error is present on each device. Allowable temperature differentials greater than 165°C indicate no overlap.

For example, if the maximum temperature differential in a system is 80°C, the only combinations of timeout multipliers that could result in timeout overlap would be a 320:480 μ s/°K (70.2°C) or a 480:640 μ s/°K (37.9°C) combination. As long as these combinations of timeout multipliers are not used in the same multidrop configuration, no overlap can occur. Thus, seven MAX6575L/H parts can be used in the same multidrop configuration if the maximum temperature differential between parts is 80°C. A similar analysis shows that four MAX6575L/H parts can be used when the maximum temperature differential extends over the entire 165°C range of the part.

Noise Considerations

The accuracy of the MAX6575L/H timeout delay is susceptible to noise generated both internally and externally. The effects of external noise can be minimized by placing a 0.1 μ F ceramic bypass capacitor close to the device's supply pin. Internal noise is inherent in the operation of the device and is detailed in Table 3. Internal averaging minimizes the effect of this noise when using longer timeout multipliers. The effects of this noise are included in the overall accuracy of the device as specified in the *Electrical Characteristics table*.

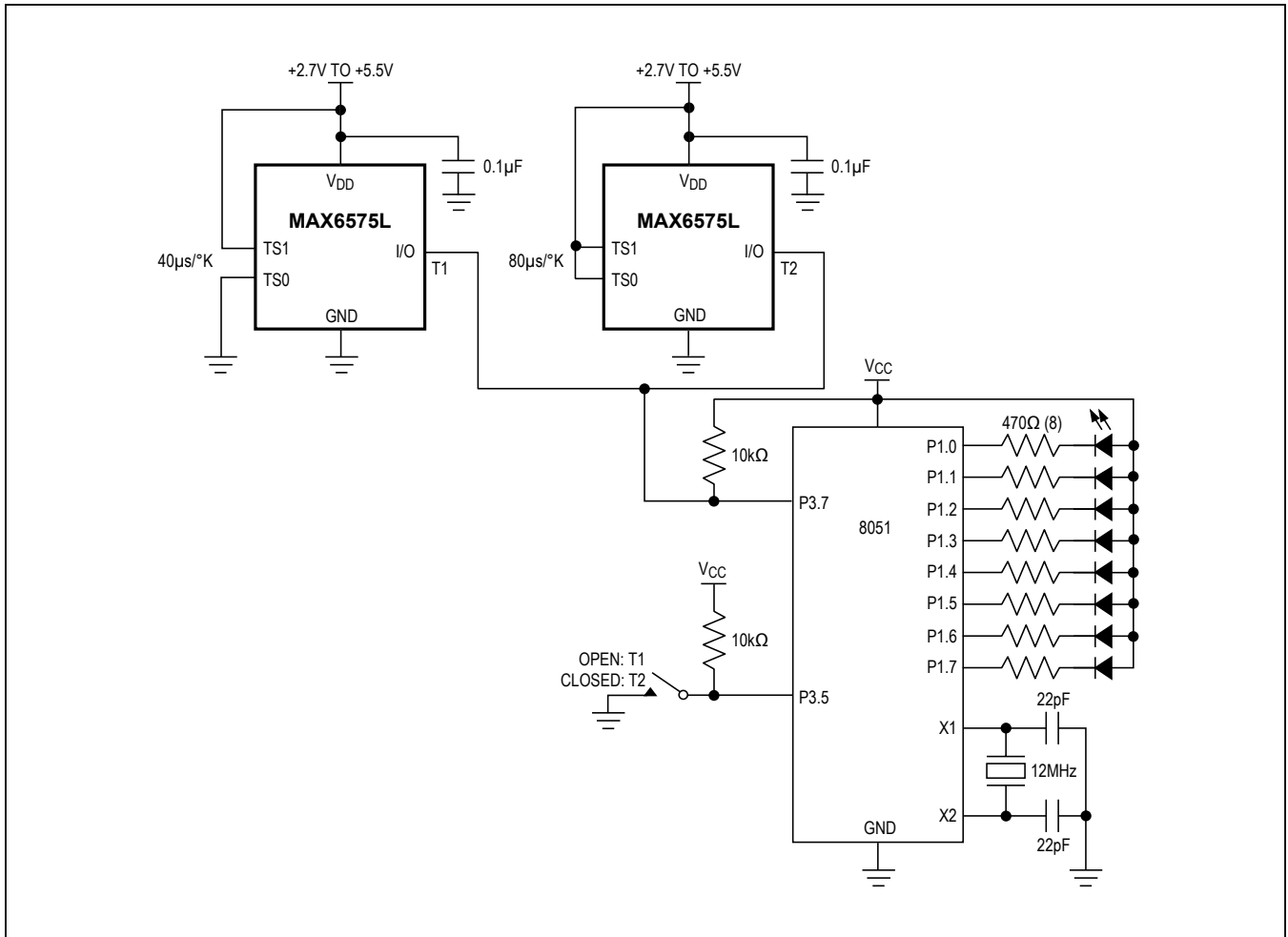

Figure 2. Interfacing Multiple Devices with a Microcontroller

Interfacing Multiple Devices with a Microcontroller

Figure 2 shows how to interface multiple MAX6575L/H devices with an 8051 microcontroller. The first device, T1, is configured for a timeout multiplier of 40µs/°K, while the second device, T2, is configured for a timeout multiplier of 80µs/°K to avoid overlap. The microcontroller takes in temperature values from both sensors, T1 and T2, on a single port pin, P3.7. The microcontroller displays five times the temperature in degrees Celsius in binary on Port 1. A switch connected to a pull-up resistor at Port 3.5 selects which temperature is displayed: open = T1, closed = T2. Code is provided for this application as Listing 1.

Listing 1. 8051 Code Example

```

;*****
; Demonstration and test code for MAX6575 Temp to Delay
; Takes in temperature values from 2 sensors on single
; port pin, P3.7 and displays temp as 5 times C in binary on
; port 1. port 3.5 selects which temp displayed- H=1, L=2.
; example: room temp= 21 C, display 105 or 01101001 on P1
;*****
;EQUATES
TEMP1H    EQU    10H            ;TEMPERATURE 1
TEMP1L    EQU    11H
TEMP2H    EQU    12H            ;TEMPERATURE 2
TEMP2L    EQU    13H

D1        EQU    30H            ;delay scratch registers
D2        EQU    31H
D3        EQU    32H

;PINS
IOPIN     BIT    P3.7           ;single pin interface
SLCT      BIT    P3.5           ;select display 1/2= H/L
;MAIN
        ORG    0                ;note one isr's used- timer overflow
        AJMP  BEGIN            ;jump over isr's

        ORG    0BH              ;timer 0 overflow- error
        CLR   TF0              ;clear timer overflow
        POP   ACC              ;unstack return address
        POP   ACC              ;unstack return address
        PUSH  LOW(DOTMP)       ;return to top on error
        PUSH  HIGH(DOTMP)      ;return to top on error
        CLR   TR0              ;clear timer run
        RETI                    ;error

        org    30h
BEGIN:    MOV   SP,#70h         ;set sp at 70H
;setup timer0 to do timing
        MOV   TMOD,#01H        ;t0 timer 16 bit
        MOV   IE,#82H          ;enable tf0 irq- error
;
;inits done- measure 2 temps
DOTMP:    MOV   TH0,#0          ;zero counter
        MOV   TL0,#0          ;zero counter
        SETB  TR0              ;start timer
        CLR   IOPIN           ;write pin low- start
        CALL  DLYP1           ;100 uS min low
        SETB  IOPIN           ;bring high

;do temp 1
        MOV   R0,#TEMP1H       ;point at temp1- high byte
        CALL  GTTP             ;get temp1

;do temp 2
        MOV   R0,#TEMP2H       ;point at temp2- high byte
        CALL  GTTP             ;get temp2

        CLR   TR0              ;stop timer- acquisition done

```

Listing 1. 8051 Code Example (continued)

```

; 2 temps are stored- display bin value of selected on P1
; temps are 40T,80T- times are in us

        MOV    R0,#TEMP1L        ;get temp1- low byte (40T)
        MOV    R4,#3 ;shift right 3x for 5x temp, div 8
        CALL  TMTOC ;convert delay to degrees C x 5
        JNB   P3.5,DSP2         ;if select low, display temp2
        MOV   A,TEMP1L         ;get temperature
        CPL   A                ;invert it for active low led's
        MOV   P1,A             ;display this temp

DSP2:   MOV    R0,#TEMP2L        ;get temp2- low byte (80T)
        MOV    R4,#4            ;shift right 4x for 5x temp, div 16
        CALL  TMTOC            ;convert delay to degrees C x 5
        JB    P3.5,DSP1        ;if select high, display temp1 above
        MOV   A,TEMP2L        ;get temperature
        CPL   A                ;invert it for active low led's
        MOV   P1,A             ;display this temp

;done

;wait for 600 ms and do it again
DSP1:   MOV    D3,#60
DLL1:   MOV    D2,#100
DLL2:   MOV    D1,#50           ;inner loop
DLLLP:  DJNZ   D1,DLLLP        ;loop 100 us
        DJNZ   D2,DLL2        ;loop 10 ms
        DJNZ   D3,DLL1        ;loop 600ms
        JMP    DOTMP          ;loop forever

;*****
;subroutines
;*****
;GET TEMP- main, capture timer0 to @r0 after pin low edge
GTPP:   JB    IOPIN,GTPP       ;wait for low- irq gets hangs
        MOV   A,TH0           ;get high- quick
        MOV   B,TLO           ;get low- quick
        CJNE  A,TH0,ROLL      ;check rollover msb
        JMP   NOROL           ;no
ROLL:   MOV   A,TH0           ;get high again
        MOV   B,TLO           ;get low again
NOROL:  MOV   @R0,A           ;stash msb
        INC   R0              ;point next
        MOV   @R0,B           ;stash lsb
WAITH:  JNB   IOPIN,WAITH     ;wait for low- irq gets hangs
        RET

;sub; converts us to degrees c x 5, R4 is # of right shifts
TMTOC:  CALL  SHRO            ;shift right
        DJNZ  R4,TMTOC        ;loop til shifted= 5x
        MOV  A,@R0           ;get x5 lsb
        CLR  C                ;ready for subb
        SUBB A,#055H         ;low byte of 273 x 5- offset
        MOV  @R0,A           ;stash back
        DEC  R0              ;point hi
        MOV  A,@R0           ;get hi- prop carry

```

Listing 1. 8051 Code Example (continued)

```

                SUBB  A,#05H           ;sub high of 273 x 5- offset
                MOV   @R0,A           ;stash back- degrees c x 5 in temp
                RET                    ;done

;shift right routine- "divide by 2" - point low on enter/exit
SHR0:          DEC   R0               ;point high
                MOV   A,@R0           ;get high
                CLR   C                ;roll 0 into msbit
                RRC   A                ;shift right
                MOV   @R0,A           ;stash back
                INC   R0               ;point low
                MOV   A,@R0           ;get low- prop carry
                RRC   A                ;shift right
                MOV   @R0,A           ;stash back
                RET                    ;pointing at lsb on exit

;short delay- 100 uS
DLYP1:         MOV   D1,#50           ;~100 uS
D1LP:          DJNZ  D1,D1LP          ;delay- also entry
                RET                    ;return after .1 ms

                END
    
```

Pin Configuration

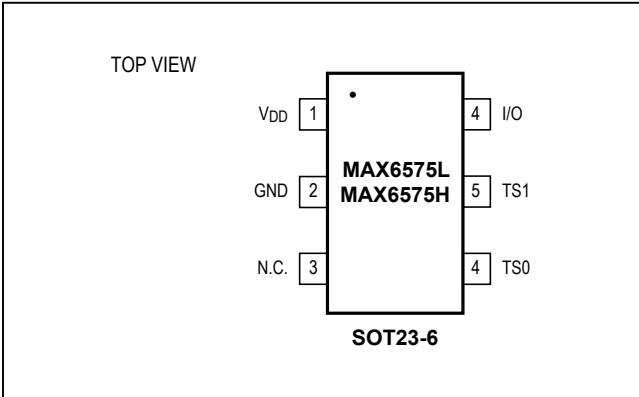

Package Information

For the latest package outline information and land patterns (footprints), go to www.maximintegrated.com/packages. Note that a "+", "#", or "-" in the package code indicates RoHS status only. Package drawings may show a different suffix character, but the drawing pertains to the package regardless of RoHS status.

PACKAGE TYPE	PACKAGE CODE	OUTLINE NO.	LAND PATTERN NO.
6 SOT23	U6-4	21-0058	90-0175

Revision History

REVISION NUMBER	REVISION DATE	DESCRIPTION	PAGES CHANGED
0	4/99	Initial release	—
1	11/14	Removed automotive reference from data sheet	1

For pricing, delivery, and ordering information, please contact Maxim Direct at 1-888-629-4642, or visit Maxim Integrated's website at www.maximintegrated.com.

Maxim Integrated cannot assume responsibility for use of any circuitry other than circuitry entirely embodied in a Maxim Integrated product. No circuit patent licenses are implied. Maxim Integrated reserves the right to change the circuitry and specifications without notice at any time. The parametric values (min and max limits) shown in the Electrical Characteristics table are guaranteed. Other parametric values quoted in this data sheet are provided for guidance.