



CODE 40 - LOW PROFILE HEAT SHRINK BOOT BACKSHELL

209M312-19B

SERIES _____
 ORDER NUMBER (TABLE 1) _____
 MATERIAL _____
 REFER TO CH00-0250-004
 FINISH _____
 REFER TO CH00-0250-004

NOTES:

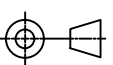
1. THIS PRODUCT IS DESIGNED TO TERMINATE A HEAT SHRINKABLE LIPPED BOOT TO A CONNECTOR.
2. FOR ADDITIONAL DIMENSIONS, ORDERING INFORMATION AND MODIFICATIONS, SEE CH00-0250-004.
3. BACKSHELL TO BE PERMANENTLY MARKED/BAGGED AND LABELLED WITH CODE IDENTIFICATION NUMBER AND PART NUMBER. (e.g. 06090-209M312-19B).
4. KNURL INSIDE BOOT GROOVE MAY BE SUPPLIED AT MANUFACTURER'S OPTION.
5. BACKSHELL MATES TO MIL-C-38999 SERIES III & IV, CLASS C, F, K AND W, D38999/20, /24, /26, /40, /46, /47 CONNECTORS AND WHEN SO MATED SHALL PROVIDE A WATER-TIGHT SEAL MEETING THE REQUIREMENTS OF MIL-C-85049, PAR. 3.5.7.

DRAWN	W.RUST	DATE	14/09/2015	 3RD ANGLE PROJECTION NOT TO SCALE	TITLE: LOW PROFILE HEAT SHRINK BOOT BACKSHELL	 Polamco 
CHECKED		DATE	14/09/2015			
APPROVED	K.SHEPPARD	DATE	09/10/2015	UNLESS OTHERWISE SPECIFIED ALL DIMENSIONS IN MILLIMETRES GENERAL TOL LINEAR +/-0,25MM ANGULAR +/- 1°	ASSY USED ON: MIL-DTL-38999 SERIES III & IV	
APPROVED	H.SMITH	DATE	14/10/2015			
REVISIONS						
LTR	DESCRIPTION	DATE	APPROVED			
F	REVISED PER ECO-15-003649	03/06/15	I.MYONG			
G	REVISED PER ECO-15-013980	14/10/2015	H.SMITH			
TE CAGE CODE: 06090 POLAMCO/TE CAGE CODE: U5792					TE CONNECTIVITY - POLAMCO LTD RESERVES THE RIGHT TO AMEND THIS DRAWING AND THE INFORMATION SET FORTH HEREON AT ANY TIME. USERS SHOULD INDEPENDENTLY EVALUATE THE SUITABILITY OF THE PRODUCT FOR THEIR APPLICATION.	DRAWING NO: 209M3XX
					DRAWING REV: G	SHT 1

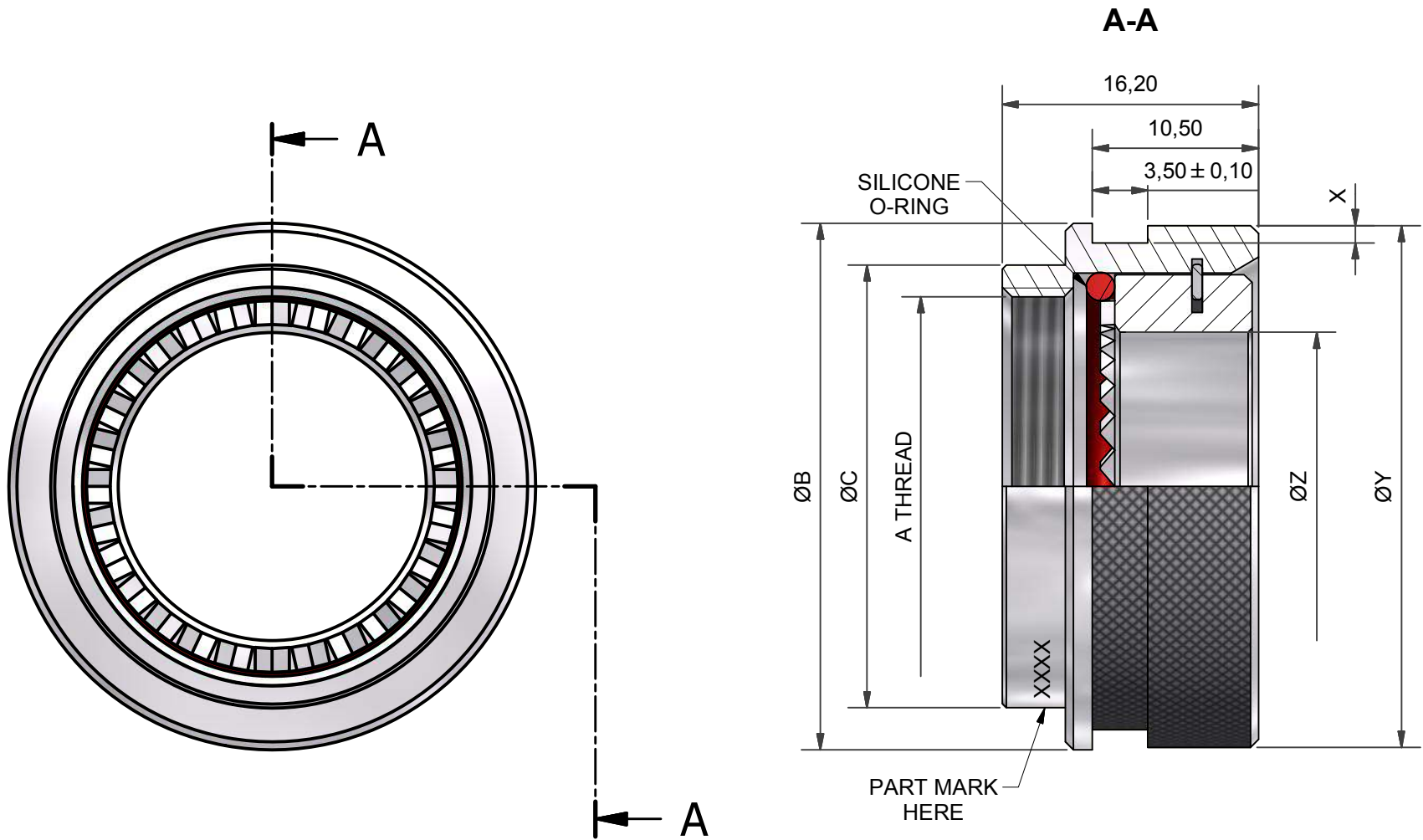
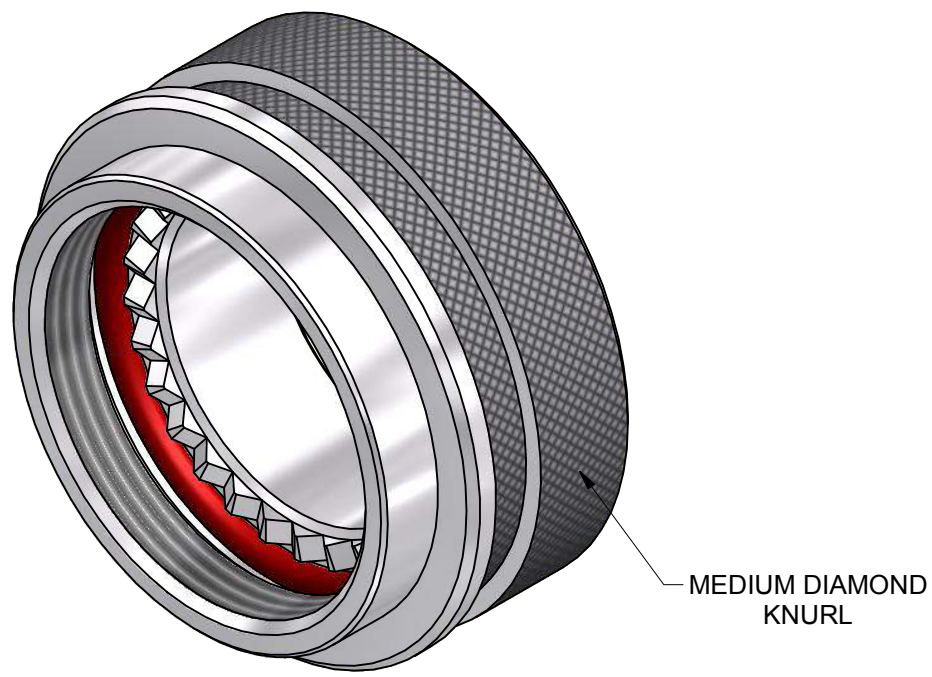

TABLE 1

BASE PART NUMBER	SHELL SIZE COM'L / MIL ⑤	A THREAD	ØB MAX	ØC MAX	X MIN	ØY +0/-0,40	ØZ ±0,15
209M308	9 / A	M12 x 1.0	19,1	15,0	1,1	17,5	6,8
209M310	11 / B	M15 x 1.0	22,3	18,0	1,1	20,7	10,3
209M312	13 / C	M18 x 1.0	25,4	21,0	1,1	23,9	13,1
209M314	15 / D	M22 x 1.0	30,3	25,0	1,1	28,7	16,3
209M316	17 / E	M25 x 1.0	33,3	28,0	1,1	33,0	19,5
209M318	19 / F	M28 x 1.0	36,5	31,0	1,1	35,0	21,9
209M320	21 / G	M31 x 1.0	38,1	34,0	1,7	36,5	25,1
209M322	23 / H	M34 x 1.0	41,3	37,0	1,7	39,8	28,3
209M324	25 / J	M37 x 1.0	44,5	40,0	1,7	43,0	31,5

DRAWN	W.RUST	DATE	14/09/2015
CHECKED		DATE	14/09/2015
APPROVED	K.SHEPPARD	DATE	09/10/2015
APPROVED	H.SMITH	DATE	14/10/2015
REVISIONS			
LTR	DESCRIPTION	DATE	APPROVED
F	REVISED PER ECO-15-003649	03/06/15	I.MYONG
G	REVISED PER ECO-15-013980	14/10/2015	H.SMITH
TE CAGE CODE: 06090 POLAMCO/TE CAGE CODE: U5792			

3RD ANGLE PROJECTION NOT TO SCALE

TITLE:
LOW PROFILE HEAT SHRINK BOOT BACKSHELL

ASSY USED ON:
MIL-DTL-38999 SERIES III & IV

UNLESS OTHERWISE SPECIFIED ALL DIMENSIONS IN MILLIMETRES
GENERAL TOL
LINEAR +/-0,25MM
ANGULAR +/- 1°

TE CONNECTIVITY - POLAMCO LTD RESERVES THE RIGHT TO AMEND THIS DRAWING AND THE INFORMATION SET FORTH HEREON AT ANY TIME. USERS SHOULD INDEPENDENTLY EVALUATE THE SUITABILITY OF THE PRODUCT FOR THEIR APPLICATION.

Polamco

TE connectivity

DRAWING NO: 209M3XX	DRAWING REV: G	SHT 2
-------------------------------	--------------------------	-----------------