

Evaluating the LT4322, Floating, High-Voltage Active Rectifier Controller**FEATURES**

- ▶ Fully featured evaluation board for the [LT4322](#)
- ▶ High voltage half-wave rectification
- ▶ AC Diode replacement

EVALUATION KIT CONTENTS

- ▶ DC3117A evaluation board

DOCUMENTS NEEDED

- ▶ LT4322 data sheet

EQUIPMENT NEEDED

- ▶ AC power supply
- ▶ Voltmeter
- ▶ Constant current or resistive load
- ▶ Oscilloscope

GENERAL DESCRIPTION

Demonstration circuit 3117A features the floating, high voltage active rectifier controller LT4322, which is suitable for applications requiring high voltage line rectification with DC outputs up to 170V. While components were chosen to optimize performance at 60Hz, the LT4322 is capable of operating at up to 100kHz.

The LT4322 drives an N-Channel MOSFET to perform half-wave rectification functionally like a diode but with much lower power dissipation. This topology eases thermal constraints and increases the usable output voltage. An N-Channel topology has multiple benefits over a P-Channel topology, including lower $R_{DS(ON)}$, a smaller footprint, lower cost, and a wider selection of MOSFETs.

Only a few essential components are required to operate the LT4322 as a half-wave rectifier: a single N-Channel MOSFET (M1), a reservoir capacitor (C1B), an AC-smoothing capacitor (C2), a gate capacitor (CG1), and in applications where the peak-to-peak input voltage exceeds 60V, an N-Channel depletion mode MOSFET (M2).

Design files for this circuit board are available at: <http://www.analog.com>.

TABLE OF CONTENTS

Features.....	1	M1 – Ideal Diode MOSFET.....	6
Evaluation Kit Contents.....	1	M2 – Depletion Mode MOSFET.....	6
Documents Needed.....	1	C1 and C1B – V_{DDA} Reservoir Capacitors.....	6
Equipment Needed.....	1	CG1 – GATE Capacitor.....	6
General Description.....	1	C2, C2-2 – Output Capacitor.....	6
DC3117A Evaluation Board Photograph.....	3	Optional Component Pads.....	7
Performance Summary.....	4	Voltage, Current, Frequency Modifications.....	7
Quick Start Procedure.....	5	Evaluation Board Schematic.....	8
Board Description.....	6	Ordering Information.....	9
Overview.....	6	Bill of Materials.....	9
U1 – The Diode Controller.....	6		

REVISION HISTORY**2/2023—Revision 0: Initial Version**

DC3117A EVALUATION BOARD PHOTOGRAPH

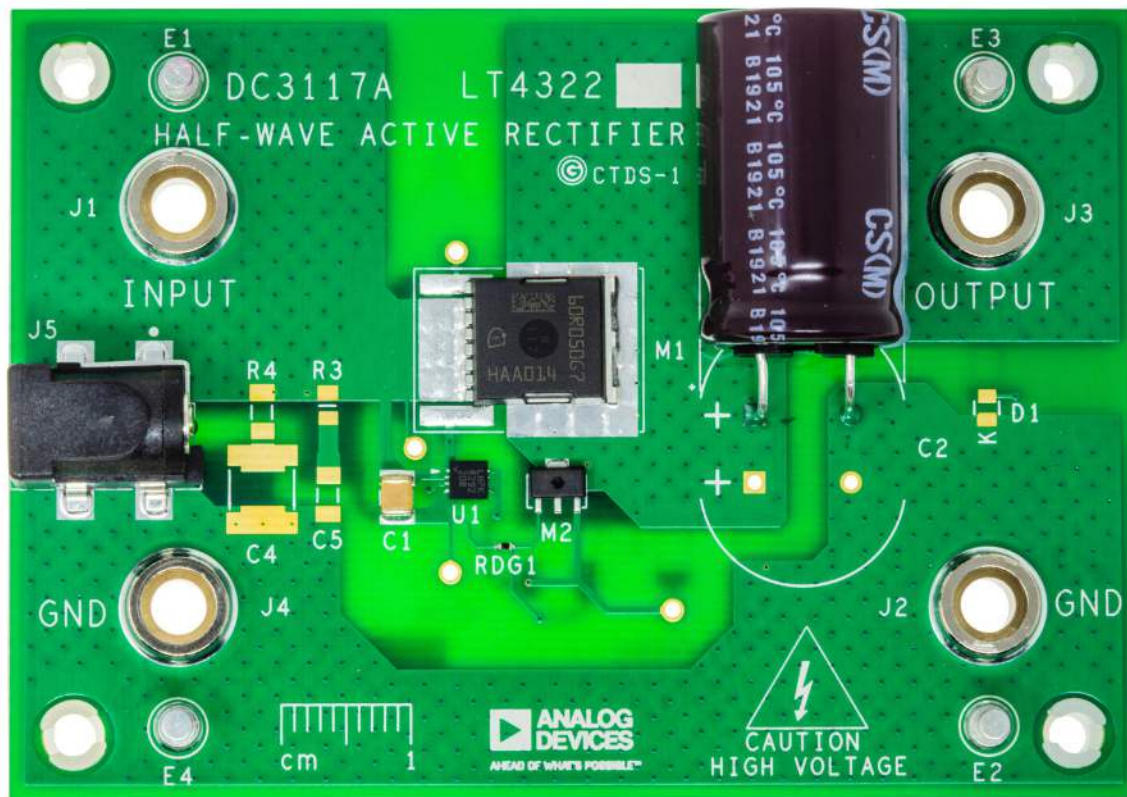

Figure 1. DC3117A Evaluation Board Photograph

PERFORMANCE SUMMARY

Specifications are at $T_A = 25^\circ\text{C}$, unless otherwise noted.

Table 1. Performance Summary¹

Parameter	Test Conditions/Comments	Min	Typ	Max	Unit
AC Input Voltage	Shorting Resistor R1 Installed	7		20	$V_{AC(RMS)}$
	No Shorting Resistor R1	7	120	140	$V_{AC(RMS)}$
Output Voltage	Shorting Resistor R1 Installed	9.5		60	V
	No Shorting Resistor R1	9.5	170	200	V
Output Current	With Installed C2, resistive load			1.2	A_{RMS}
	With Additional C2, resistive load			5	A_{RMS}

¹ Generated using default components from the Parts List.

QUICK START PROCEDURE

WARNING! High voltage testing should be performed by qualified personnel only. As a safety precaution, at least two people should be present during high voltage testing. There are exposed conductors on the bottom of the board, and any banana plugs present will protrude through the bottom of the board. The underlying surface should be non-conductive and clear of any wire, solder, and other conductive debris.

A simple demonstration of DC3117A operation is as follows:

1. Connect an AC power supply to input and GND, as shown in Figure 2. Make sure that the output voltage of the supply is within the input voltage range of the DC3117A, as shown in Table 1. Verify that shorting resistor R1 has been removed before exceeding $20V_{AC(RMS)}$. Take care not to exceed 24V or 5A when using the barrel jack (J5). Use the turrets (E1 to E4) and banana jacks (J1 to J4) in all valid current/voltage ranges.
2. Connect a load and voltmeter across output and GND, as shown in Figure 2. Turn down the load current to zero. Put the voltmeter in DC volt measurement mode.
3. Raise the AC input power supply voltage to the desired level. Check the output voltage with the voltmeter. For cases where the input supply is a $120V_{AC}$ line voltage, the voltmeter reads $\sim 170V_{DC}$.
4. Raise the load current to the desired level. Make sure that the load current is within the maximum load current, as shown in Table 1. The installed $150\mu F$ output smoothing capacitor (UCS2D151MHD C2) ripple current rating allows a load up to $1.2A_{RMS}$ at $25^{\circ}C$. Connect an additional C2 or choose a capaci-

tor with a higher ripple current rating than the UCS2D151MHD for larger loads, up to $5A_{RMS}$.

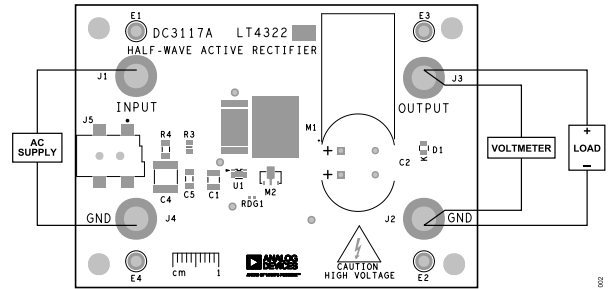

Figure 2. Measurement Equipment Setup

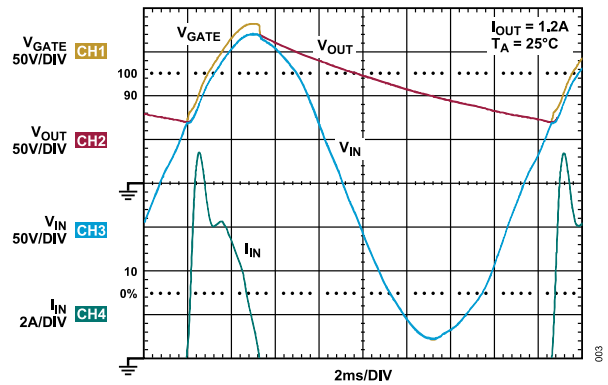

Figure 3. Typical Performance Under $1.2A_{RMS}$ Resistive Load

BOARD DESCRIPTION

OVERVIEW

DC3117A features an [LT4322](#) controlling an N-Channel MOSFET to provide a highly efficient, compact, and low-profile solution for half-wave rectification. Careful attention has been paid to the board layout to provide at least 104mil (2.6mm) clearance between the larger copper planes and as much clearance as possible between components and traces to ensure DC3117A operation up to the maximum voltage of the chosen components.

DC3117A is a 2-layer board with 2oz copper on each layer. The copper in the power path can carry 20A continuously, depending on ambient conditions. Furthermore, all copper planes in the power-path are doubled on the bottom copper layer where possible. With the default components however, the load current is limited to 1.2A_{RMS} by the ripple current rating of C2.

After replacing C2 with a 2.2mF capacitor, the load current can be increased to 5A_{RMS} at an ambient temperature of 25°C. At 5A_{RMS} load the package temperature of the IPT60R050G7 reaches 95°C.

For ease of evaluation probe points have been provided for the LT4322 pins.

The following is a brief description of the main components of DC3117A.

U1 – THE DIODE CONTROLLER

U1 is the LT4322 in an 8-pin, 3mm x 3mm side-wettable DFN package. For more details, refer to the LT4322 data sheet on its operation.

M1 – IDEAL DIODE MOSFET

M1 is the Infineon N-Channel MOSFET IPT60R050G7 in an HSOFF package. It was selected for its 600V drain-to-source breakdown voltage, $\pm 20V$ $V_{GS(MAX)}$, and 43m Ω drain-to-source on-state resistance (at 10V V_{GS}). M1's $\pm 20V$ $V_{GS(max)}$ is compatible with the 12V limit on LT4322's gate drive. When the input and output are at -170V and +170V respectively (peak AC line voltage), M1's drain-to-source voltage is at 340V. This is comfortably below M1's 600V drain-to-source breakdown voltage specification.

M2 – DEPLETION MODE MOSFET

M2 is the Microchip N-Channel depletion mode MOSFET DN2450K4 in a TO-243AA (SOT-89) package. It was selected for its 500V drain-to-source breakdown voltage and 700mA I_{DSS} . When input is at -170V and output is at 170V, M2's drain-to-source voltage is close to 340V, safely below its 500V breakdown specification. The 700mA I_{DSS} allows the 50mA to 100mA peak current required by the LT4322 V_{DDC} pin while refreshing its V_{DDA} reservoir capacitor.

C1 AND C1B – V_{DDA} RESERVOIR CAPACITORS

Due to their strong voltage coefficient, the actual value of multilayer ceramic capacitors is often significantly less than what is stated, especially at voltages close to the capacitor's maximum voltage rating. Additionally, the voltage coefficient is a function of the capacitor's physical size. A 2220, 25V-rated ceramic capacitor is chosen for C1B to achieve a true value of 22 μ F at the 12V operating voltage for this 60Hz application.

Alternatively, for 60Hz applications, users can populate C1 with a 0.1 μ F ceramic capacitor and solder a 22 μ F aluminum electrolytic capacitor between the LT4322's V_{DDA} pin and the input trace instead of populating C1B. For input frequencies ≥ 200 Hz, users can leave C1B unpopulated and populate only C1.

CG1 – GATE CAPACITOR

The LT4322 is optimally compensated with a 10nF capacitance between the gate and source of the external power MOSFET. The necessity of CG1 is dependent on the choice of M1 and its inherent C_{ISS} value. In the case of the IPT60R050G7, CG1 is populated with a 10nF capacitor to improve stability in forward regulation. For more details, refer to the Gate Capacitor Selection section of the LT4322 data sheet.

C2, C2-2 – OUTPUT CAPACITOR

Output capacitors C2 and C2-2 provide the output load current for the majority of the AC period. For more details, refer to Output Capacitor C_{OUT} Selection of the LT4322 data sheet on selecting the capacitance value as a function of output load current, AC period, and maximum allowed output voltage droop. [Figure 3](#) shows the output voltage droop from 170V to 72V for a 1.2A_{RMS} resistive load and 16.7ms period (60Hz) when C2 = 150 μ F.

Users must also ensure that the RMS current in the capacitor does not exceed the maximum ripple current rating so that the capacitor lifetime is not compromised. An electrolytic capacitor's ripple current rating is a function of RMS current, frequency, and ambient temperature. Consult the manufacturer's specifications and ensure that the selected device is suited to operate within the required frequency, temperature, and load current conditions of the application.

BOARD DESCRIPTION

OPTIONAL COMPONENT PADS

Some components (M1, M2, C2, and C3) are provided with extra unstuffed pads to try out different values and sizes or other circuits from the [LT4322](#) data sheet. Some of these extra pads are on the backside of the board.

M1 has a universal MOSFET footprint on both outer layers to accommodate power-SO8, DPAK, D2PAK, HSO8, and LFPAK packages. Users can populate the top and bottom M1 footprints simultaneously to connect two power MOSFETs in parallel, thereby reducing the total MOSFET power loss by a factor of two. M2 has a footprint on the backside for the DPAK package.

While the board is populated with a single aluminum electrolytic capacitor C2 on the output voltage by default, there are footprints for another aluminum electrolytic capacitor C2-2 and a multilayer ceramic capacitor C3 on the output. This allows users to try various combinations of total output capacitance and ESR with various output current loads.

Components R3, R4, C4, and C5 are provided to facilitate optional snubbing networks. Though they are populated by default, they are unnecessary in most applications. For more details, refer to the Input Snubber section of the [LT4322](#) data sheet.

VOLTAGE, CURRENT, FREQUENCY MODIFICATIONS

For higher voltage operation, see [Table 2](#) and ensure that the stated components meet or exceed the minimum voltage requirement for the desired input/output voltages. Due to the half-wave topology, take note that components M1 and M2 must be able to withstand the entire peak-to-peak voltage of the input supply.

To modify the board for higher current, try the following in this order, while still ensuring all board components meet or exceed the minimum requirements outlined in [Table 2](#):

1. Raise the C2 value and ripple current capacity
2. Select an M1 replacement with a lower $R_{DS(ON)}$ value
3. Add a second matching FET in parallel using the backside MOSFET footprint

For applications using an AC input supply less than $20V_{RMS}$, R1 can be installed to short M2 from the circuit. For higher frequency AC input, it is optimal to pick a lower value C1 even though the installed value works. For frequencies below 60Hz, C1 must be increased. For more details, refer to the V_{DDA} Capacitor Selection section of the [LT4322](#) data sheet.

Table 2. Voltage Requirements

Part Reference	Minimum Voltage Requirement
C1, C1B, CG1	16V
C2, C3, C4, C5	$V_{IN(PEAK)}$ or Desired $V_{OUT(MAXDC)}$
M1, M2	$BV_{DSS} \geq V_{IN(PEAK-PEAK)}$

EVALUATION BOARD SCHEMATIC

P00

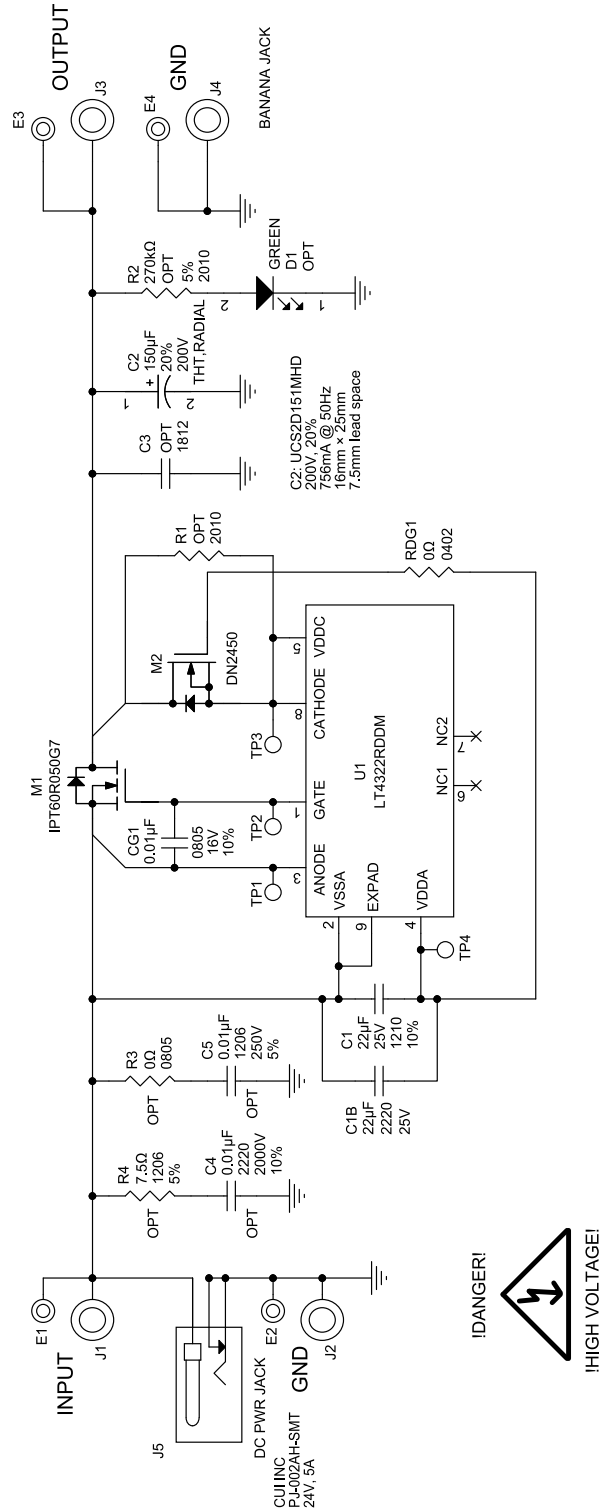

HIGH VOLTAGE

Figure 4. DC3117A Schematic Diagram

ORDERING INFORMATION

BILL OF MATERIALS

Table 3. DC3117A Bill of Materials

Item	Quantity	Reference Designator	Part Description	Manufacturer, Part Number
Required Circuit Components				
1	1	C1	Capacitor, 22 μ F, X7R, 25 V, 10%, 1210	AVX, 12103C226KAT2A Kemet, GRM32ER71E226KE15L Murata, CL32B226KAJNNNE Samsung, CL32B226KAJNNNE
2	1	C2	Capacitor, 150 μ F, Aluminium Electrolytic, 200 V, 20%, THT, Radial	Nichicon, UCS2D151MHD
3	1	C1B	Capacitor, CER 22 μ F, 25 V, X7R, 2220	Kemet, C2220C226K3RAC7800 Kyocera AVX, 22203C226KAZ2A Cal-chip Electronics, GMC55X7R226K25NT
4	1	M1	Transistor, N-Channel MOSFET, 650 V, 44 A, HSOF-8	Infineon, IPT60R050G7 Infineon, IPT60R050G7XTMA1
5	1	M2	Transistor, N-Channel MOSFET, Depletion Mode, 500 V, 230 mA, SOT-243AA (SOT-89)	Microchip, DN2450N8-G
6	1	RDG1	Resistor, 0 Ω , 1/16 W, 0402	NIC, NRC04ZOTRF R Ω , MCR01MZPJ000 Vishay, CRCW04020000Z0ED Yageo, RC0402JR-070RL
7	1	U1	IC, Active Bridge Ideal Diode Controller, DFN-8	ANALOG DEVICES, LT4322RDDM#PBF
Additional Demo Board Circuit Components				
8	0	C2-2	Capacitor, 150 μ F, Aluminium Electrolytic, 200 V, 20%, THT, Radial	Nichicon, UCS2D151MHD
9	1	C4	Capacitor, 0.01 μ F, X7R, 2000 V, 10%, 2220	Kemet, C2220C103KGRACTU
10	1	C5	Capacitor, 0.01 μ F, U2J, 250 V, 5%, 1206	Murata, GRM31B7U2E103JW31
11	0	C3	Capacitor, Option, 1812	
12	1	CG1	Capacitor, 0.01 μ F, X7R, 16 V, 10%, 0805	Würth Elektronik, 885012207039
13	1	D1	LED, Green, Water-clear, 0805	Würth Elektronik, 150080GS75000
14	0	M1-1	Transistor, N-Channel MOSFET, 650 V, 44 A, HSOF-8	Infineon, IPT60R050G7 Infineon, IPT60R050G7XTMA1
15	0	M2-1	Transistor, N-Channel MOSFET, Depletion Mode, 500 V, 350 mA, TO -252AA (D-PAK)	Microchip, DN2450K4-G
16	0	R1	Resistor, Option, 2010	
17	1	R2	Resistor, 270 k Ω , 5%, 3/4W, 2010, AEC-Q200	Panasonic, ERJ-12ZYJ274U
18	1	R3	Resistor, 0 Ω , 1/8 W, 0805	Yageo, RC0805JR-070RL
19	1	R4	Resistor, 7.5 Ω , 5%, 1/4 W, 1206	Yageo, RC1206JR-077R5L
Hardware: For Demo Board Only				
20	4	E1,E2,E3,E4	Test points, turret, 0.094" MTG. hole, PCB 0.062" THK	Mill-Max, 2501-2-00-80-00-00-07-0
21	4	J1,J2,J3,J4	Connectors, Banana Jack, Female , THT, Non-Insulated, , Swage , 0.218"	Keystone, 575-4
22	1	J5	Connectors, DC PWR Jack , Female, 3 Term, 1 Port, 2 mm ID, 6.5 mm OD, HORZ, R/A, SMT, 24 V _{DC} , 5 A	CUI INC., PJ-002AH-SMT-TR

ORDERING INFORMATION

Table 3. DC3117A Bill of Materials (Continued)

Item	Quantity	Reference Designator	Part Description	Manufacturer, Part Number
23	1	LB1	Label Spec, Demo Board Serial Number	Brady, THT-96-717-10
24	4	MP5, MP6, MP7, MP8	Standoff, Nylon, Snap-On, 0.25" (6.4 mm)	Keystone, 8831 Wurth Elektronik, 702931000
25	1	PCB1	PCB, DC3117A	Approved Supplier, 600-DC3117A
26	0	TP1, TP2, TP3, TP4	Test points, 0.044", 0.275 L x 0.093 W, TH	Keystone, 1036

**ESD Caution**

ESD (electrostatic discharge) sensitive device. Charged devices and circuit boards can discharge without detection. Although this product features patented or proprietary protection circuitry, damage may occur on devices subjected to high energy ESD. Therefore, proper ESD precautions should be taken to avoid performance degradation or loss of functionality.

Legal Terms and Conditions

By using the evaluation board discussed herein (together with any tools, components documentation or support materials, the "Evaluation Board"), you are agreeing to be bound by the terms and conditions set forth below ("Agreement") unless you have purchased the Evaluation Board, in which case the Analog Devices Standard Terms and Conditions of Sale shall govern. Do not use the Evaluation Board until you have read and agreed to the Agreement. Your use of the Evaluation Board shall signify your acceptance of the Agreement. This Agreement is made by and between you ("Customer") and Analog Devices, Inc. ("ADI"), with its principal place of business at Subject to the terms and conditions of the Agreement, ADI hereby grants to Customer a free, limited, personal, temporary, non-exclusive, non-sublicensable, non-transferable license to use the Evaluation Board FOR EVALUATION PURPOSES ONLY. Customer understands and agrees that the Evaluation Board is provided for the sole and exclusive purpose referenced above, and agrees not to use the Evaluation Board for any other purpose. Furthermore, the license granted is expressly made subject to the following additional limitations: Customer shall not (i) rent, lease, display, sell, transfer, assign, sublicense, or distribute the Evaluation Board; and (ii) permit any Third Party to access the Evaluation Board. As used herein, the term "Third Party" includes any entity other than ADI, Customer, their employees, affiliates and in-house consultants. The Evaluation Board is NOT sold to Customer; all rights not expressly granted herein, including ownership of the Evaluation Board, are reserved by ADI. CONFIDENTIALITY. This Agreement and the Evaluation Board shall all be considered the confidential and proprietary information of ADI. Customer may not disclose or transfer any portion of the Evaluation Board to any other party for any reason. Upon discontinuation of use of the Evaluation Board or termination of this Agreement, Customer agrees to promptly return the Evaluation Board to ADI. ADDITIONAL RESTRICTIONS. Customer may not disassemble, decompile or reverse engineer chips on the Evaluation Board. Customer shall inform ADI of any occurred damages or any modifications or alterations it makes to the Evaluation Board, including but not limited to soldering or any other activity that affects the material content of the Evaluation Board. Modifications to the Evaluation Board must comply with applicable law, including but not limited to the RoHS Directive. TERMINATION. ADI may terminate this Agreement at any time upon giving written notice to Customer. Customer agrees to return to ADI the Evaluation Board at that time. LIMITATION OF LIABILITY. THE EVALUATION BOARD PROVIDED HEREUNDER IS PROVIDED "AS IS" AND ADI MAKES NO WARRANTIES OR REPRESENTATIONS OF ANY KIND WITH RESPECT TO IT. ADI SPECIFICALLY DISCLAIMS ANY REPRESENTATIONS, ENDORSEMENTS, GUARANTEES, OR WARRANTIES, EXPRESS OR IMPLIED, RELATED TO THE EVALUATION BOARD INCLUDING, BUT NOT LIMITED TO, THE IMPLIED WARRANTY OF MERCHANTABILITY, TITLE, FITNESS FOR A PARTICULAR PURPOSE OR NON-INFRINGEMENT OF INTELLECTUAL PROPERTY RIGHTS. IN NO EVENT WILL ADI AND ITS LICENSORS BE LIABLE FOR ANY INCIDENTAL, SPECIAL, INDIRECT, OR CONSEQUENTIAL DAMAGES RESULTING FROM CUSTOMER'S POSSESSION OR USE OF THE EVALUATION BOARD, INCLUDING BUT NOT LIMITED TO LOST PROFITS, DELAY COSTS, LABOR COSTS OR LOSS OF GOODWILL. ADI'S TOTAL LIABILITY FROM ANY AND ALL CAUSES SHALL BE LIMITED TO THE AMOUNT OF ONE HUNDRED US DOLLARS (\$100.00). EXPORT. Customer agrees that it will not directly or indirectly export the Evaluation Board to another country, and that it will comply with all applicable United States federal laws and regulations relating to exports. GOVERNING LAW. This Agreement shall be governed by and construed in accordance with the substantive laws of the Commonwealth of Massachusetts (excluding conflict of law rules). Any legal action regarding this Agreement will be heard in the state or federal courts having jurisdiction in Suffolk County, Massachusetts, and Customer hereby submits to the personal jurisdiction and venue of such courts. The United Nations Convention on Contracts for the International Sale of Goods shall not apply to this Agreement and is expressly disclaimed.

