

ISL68220

Digital Dual Output, 2-Phase PWM Controller

The [ISL68220](#) is a digital dual output multiphase ($X+Y \leq 2$) PWM controller with PMBus V1.3 compatibility. The controller can be configured to support any required phase assignments up to a maximum of two phases across the two outputs (X and Y). For example, 1+1, 1+0, or even single output operation as a 2+0 configuration are supported. When combined with the Renesas family of Smart Power Stages and DrMOS devices, designs of exceptional density and performance can be created.

The ISL68220 uses the proprietary Renesas digital synthetic current modulation scheme to achieve the industry-best combination of transient response, ease of tuning, and efficiency across the full load range. Diode emulation and automatic phase add/drop features allow you to extract maximum efficiency from the converter regardless of load conditions. You can use the intuitive Renesas PowerNavigator™ to configure and monitor the device.

With minimal external components, easy configuration, robust fault management, and highly accurate regulation capability, implementing a high-performance, multiphase regulator has never been easier.

Applications

- DDR memory solutions
- Artificial intelligence/accelerator cards (FPGA, ASIC)
- Network equipment
- Server/storage equipment
- Telecom/datacom equipment
- Point-of-load power supply (memory, DSP, ASIC, FPGA)

Related Literature

For a full list of related documents, visit our website:

- [ISL68220](#) device page

Features

- Advanced linear digital modulation scheme
 - Auto phase add/drop with PFM mode for excellent load vs efficiency profile
 - Dual edge modulation with optional diode braking for faster transient response
 - Excellent VOUT transition performance
 - Zero latency synthetic current control for excellent high-frequency current balance
- Flexible phase assignment from 0 to 2 phases per output
- Up to 2MHz switching frequency operation for high density designs
- Differential remote voltage sensing supports $\pm 0.5\%$ closed-loop system accuracy over load, line, and temperature
- Highly accurate current sensing for excellent load-line regulation and accurate OCP
 - Supports the full range of Renesas Smart Power Stage (SPS) devices
- Comprehensive fault management enables high reliability systems
 - Pulse-by-pulse (per phase) and total output current limiting
 - Black Box status recording capability with first fault indicator
- Intuitive configuration using [PowerNavigator](#)
- SMBus/PMBus V1.3 compatible
- Up to 16 user configurations stored in device Non-Volatile Memory (NVM)

Contents

1. Overview	6
1.1 Typical Application	6
1.2 Internal Block Diagram	7
1.3 Ordering Information	8
1.4 Pin Configuration	9
1.5 Functional Pin Descriptions	10
2. Specifications	11
2.1 Absolute Maximum Ratings	11
2.2 Thermal Information	11
2.3 Recommended Operating Conditions	11
2.4 Electrical Specifications	12
3. Initializing the Device	14
3.1 Power-On Reset (POR)	14
3.2 Selecting the PMBus Address	15
3.3 Selecting the User Configurations	15
3.4 Configuring the Device	16
4. Operating the Device	17
4.1 Input Voltage Sensing	17
4.2 Lossless Input Current and Power Sensing	17
4.3 VMON Voltage Sensing	17
4.4 Enabling and Soft-Starting the Device	18
4.5 Disabling the Device	18
4.6 Phase Configuration and Automatic Phase Dropping	18
4.7 Diode Emulation and PFM Operation	19
4.8 Diode Braking	20
4.9 Switching Frequency	20
4.10 Output Current Sensing	20
5. Temperature Sensing	23
5.1 SPS Temperature Sensing	23
5.2 NTC Temperature Sensing	23
5.3 Temperature Compensation	24
6. Fault Monitoring and Protection	25
6.1 Power-Good Signals	25
6.2 Overvoltage/Undervoltage Protection	25
6.3 Output Overcurrent Protection	26
6.4 Smart Power Stage OC Fault Detect	27
6.5 Thermal Protection and nVRHOT	27
6.6 Catastrophic Failure Protection	28
6.7 Black Box Recorder	28
7. Layout and Design Considerations	29
7.1 Pin Noise Sensitivity, Design, and Layout Consideration	29

8.	PMBus Protocol	30
8.1	Send Byte Protocol	30
8.2	Write Byte/Word Protocol	30
8.3	Read Byte/Word Protocol	31
8.4	Group Command Protocol	31
8.5	Alert Response Address	31
9.	PMBus Commands Summary	32
9.1	PMPMBus Use Guidelines	35
9.2	PMBus Data Formats	35
10.	PMBus Command Detail	36
10.1	PAGE (00h)	36
10.2	OPERATION (01h)	37
10.3	ON_OFF_CONFIG (02h)	38
10.4	CLEAR_FAULTS (03h)	38
10.5	PHASE (04h)	39
10.6	PAGE_PLUS_WRITE (05h)	39
10.7	PAGE_PLUS_READ (06h)	40
10.8	WRITE_PROTECT (10h)	40
10.9	CAPABILITY (19h)	41
10.10	SMBALERT_MASK (1Bh)	42
10.11	VOUT_MODE (20h)	42
10.12	VOUT_COMMAND (21h)	43
10.13	VOUT_TRIM (22h)	43
10.14	VOUT_CAL_OFFSET (23h)	44
10.15	VOUT_MAX (24h)	44
10.16	VOUT_MARGIN_HIGH (25h)	45
10.17	VOUT_MARGIN_LOW (26h)	45
10.18	VOUT_TRANSITION_RATE (27h)	46
10.19	VOUT_DROOP (28h)	46
10.20	VOUT_MIN (2Bh)	47
10.21	FREQUENCY_SWITCH (33h)	47
10.22	POWER_MODE (34h)	48
10.23	VIN_ON (35h)	49
10.24	VIN_OFF (36h)	49
10.25	VOUT_OV_FAULT_LIMIT (40h)	50
10.26	VOUT_OV_FAULT_RESPONSE (41h)	51
10.27	VOUT_UV_FAULT_LIMIT (44h)	52
10.28	VOUT_UV_FAULT_RESPONSE (45h)	53
10.29	IOUT_OC_FAULT_LIMIT (46h)	54
10.30	IOUT_OC_FAULT_RESPONSE (47h)	55
10.31	OT_FAULT_LIMIT (4Fh)	56
10.32	OT_FAULT_RESPONSE (50h)	57
10.33	OT_WARN_LIMIT (51h)	58
10.34	UT_FAULT_LIMIT (53h)	58
10.35	UT_FAULT_RESPONSE (54h)	59
10.36	VIN_OV_FAULT_LIMIT (55h)	60
10.37	VIN_OV_FAULT_RESPONSE (56h)	61
10.38	VIN_OV_WARN_LIMIT (57h)	62

10.39	VIN_UV_WARN_LIMIT (58h)	62
10.40	VIN_UV_FAULT_LIMIT (59h)	63
10.41	VIN_UV_FAULT_RESPONSE (5Ah)	64
10.42	IIN_OC_FAULT_LIMIT (5Bh)	65
10.43	IIN_OC_FAULT_RESPONSE (5Ch)	66
10.44	IIN_OC_WARN_LIMIT (5Dh)	67
10.45	TON_DELAY (60h)	67
10.46	TON_RISE (61h)	68
10.47	TOFF_DELAY (64h)	68
10.48	TOFF_FALL (65h)	69
10.49	STATUS_BYTE (78h)	70
10.50	STATUS_WORD (79h)	71
10.51	STATUS_VOUT (7Ah)	72
10.52	STATUS_IOUT (7Bh)	72
10.53	STATUS_INPUT (7Ch)	73
10.54	STATUS_TEMPERATURE (7Dh)	73
10.55	STATUS_CML (7Eh)	74
10.56	STATUS_MFR_SPECIFIC (80h)	75
10.57	READ_VIN (88h)	75
10.58	READ_IIN (89h)	76
10.59	READ_VOUT (8Bh)	76
10.60	READ_IOUT (8Ch)	77
10.61	READ_TEMPERATURE_1 (8Dh)	77
10.62	READ_TEMPERATURE_2 (8Eh)	78
10.63	READ_TEMPERATURE_3 (8Fh)	78
10.64	READ_POUT (96h)	79
10.65	READ_PIN (97h)	79
10.66	PMBUS_REVISION (98h)	80
10.67	MFR_ID (99h)	80
10.68	MFR_MODEL (9Ah)	80
10.69	MFR_REVISION (9Bh)	81
10.70	MFR_DATE (9Dh)	81
10.71	IC_DEVICE_ID (ADh)	81
10.72	IC_DEVICE_REV (AEh)	82
10.73	DMAFIX (C5h)	82
10.74	DMASEQ (C6h)	82
10.75	DMAADDR (C7h)	83
10.76	PEAK_OC_LIMIT (CDh)	83
10.77	PEAK_UC_LIMIT (CEh)	84
10.78	VMON_ON (D0h)	84
10.79	VMON_OFF (D1h)	85
10.80	COMPPROP (DDh)	86
10.81	COMPINTEG (DEh)	87
10.82	COMPIDFF (DFh)	88
10.83	COMPCFB (E0h)	88
10.84	HS_BUS_CURRENT_SCALE (E3h)	89
10.85	PHASE_CURRENT (E4h)	90
10.86	PHASE_TEMPERATURE (E5h)	90
10.87	PEAK_OCUC_COUNT (E9h)	91
10.88	SLOW_IOUT_OC_LIMIT (EAh)	92

10.89	FAST_OC_FILT_COUNT (EBh)	93
10.90	SLOW_OC_FILT_COUNT (ECh).....	93
10.91	LOOPCFG (F0h)	94
10.92	RESTORE_CFG (F2h)	95
11.	Revision History.....	96
12.	Package Outline Drawing	97

1. Overview

1.1 Typical Application

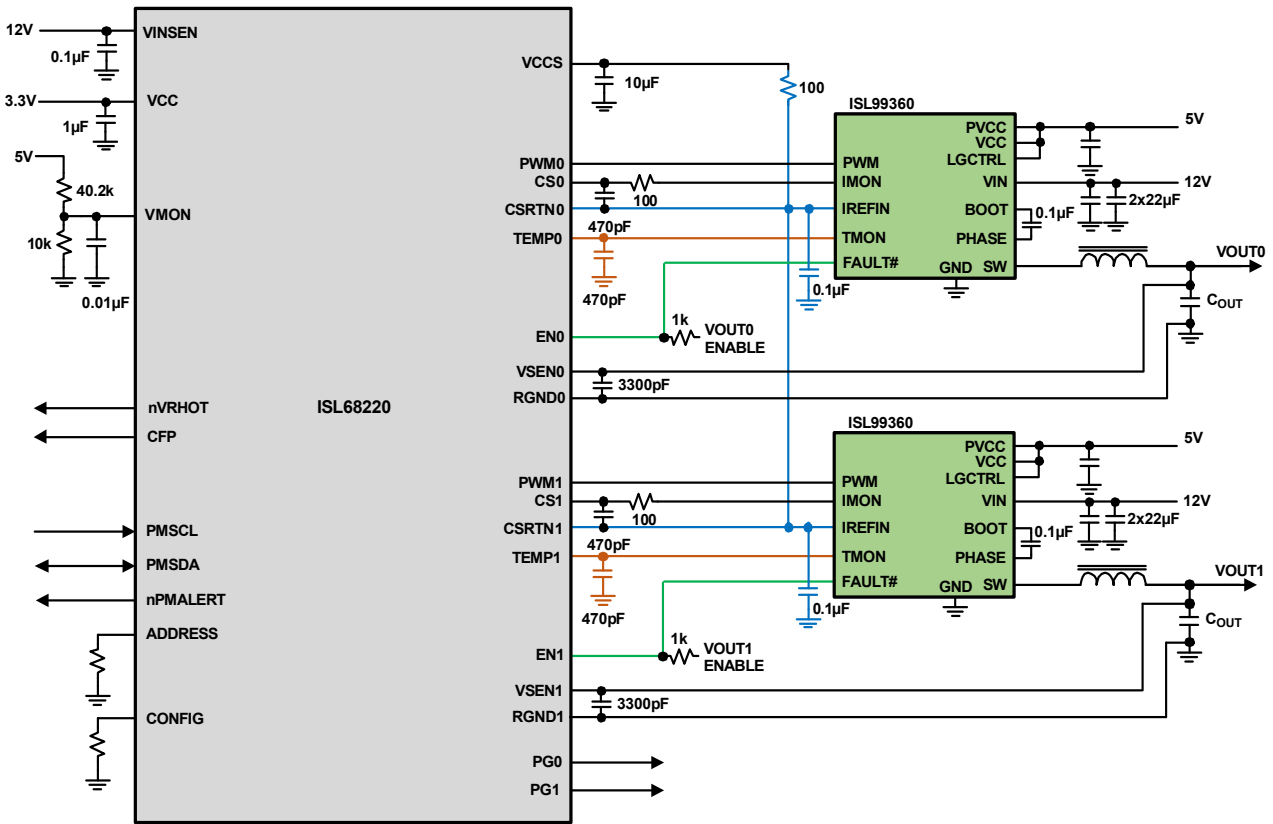

Figure 1. 1+1 Solution Using Smart Power Stage

1.2 Internal Block Diagram

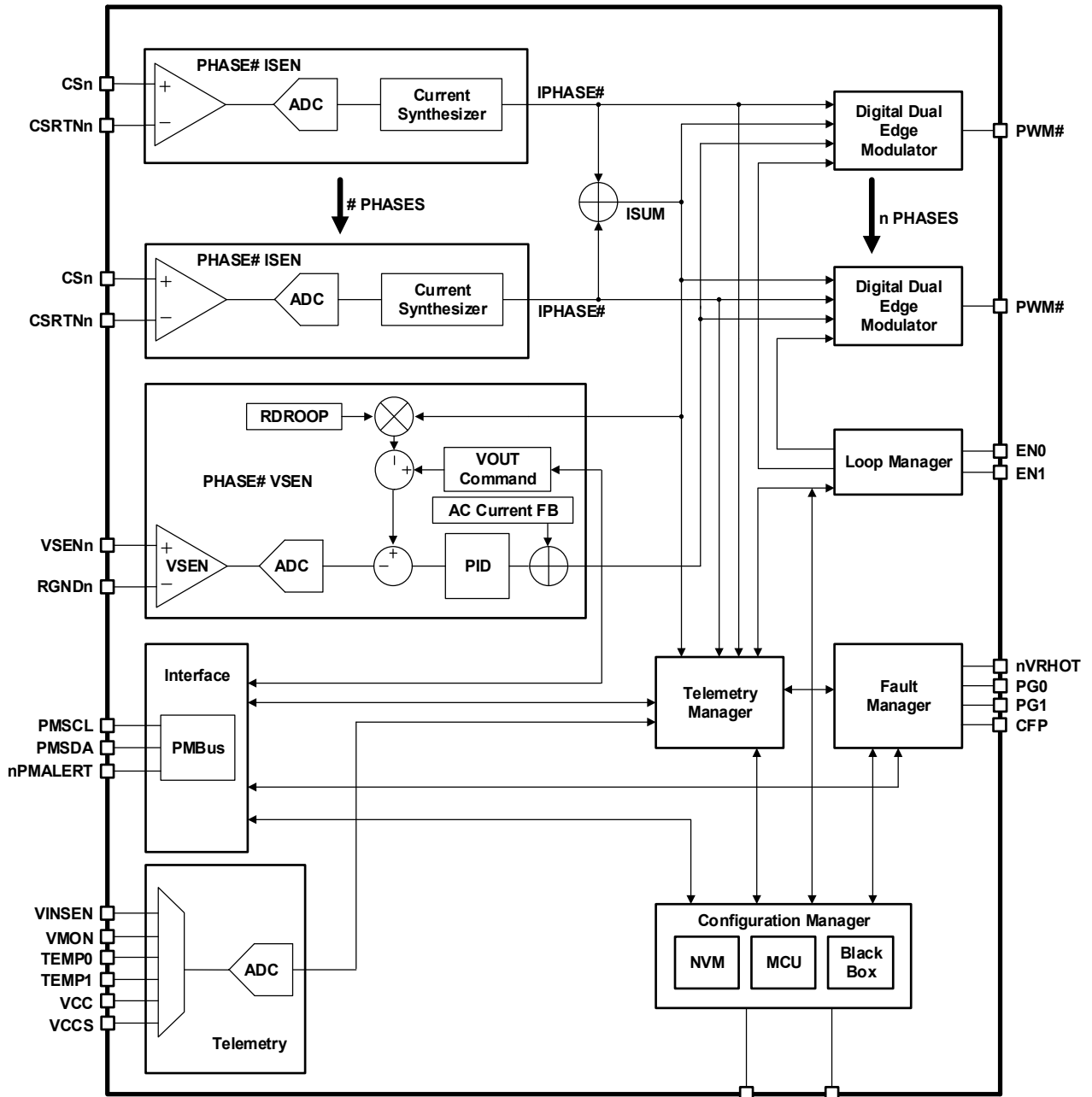

Figure 2. Internal Block Diagram

1.3 Ordering Information

Part Number (Notes 2, 3)	Part Marking	Junction Temperature (°C)	Tape and Reel (Units) (Note 1)	Package (RoHS Compliant)	Pkg. Dwg. #
ISL68220IRAZ	ISL68220 IRZ	-40 to +125	-	32 Ld 4x4 QFN	L32.4x4D
ISL68220IRAZ-T	ISL68220 IRZ	-40 to +125	6k	32 Ld 4x4 QFN	L32.4x4D
ISL68220IRAZ-T7A	ISL68220 IRZ	-40 to +125	250	32 Ld 4x4 QFN	L32.4x4D

Notes:

- See [TB347](#) for details about reel specifications.
- These Pb-free plastic packaged products employ special Pb-free material sets, molding compounds/die attach materials, and 100% matte tin plate plus anneal (e3 termination finish, which is RoHS compliant and compatible with both SnPb and Pb-free soldering operations). Pb-free products are MSL classified at Pb-free peak reflow temperatures that meet or exceed the Pb-free requirements of IPC/JEDEC J-STD-020.
- For Moisture Sensitivity Level (MSL), see the [ISL68220](#) device page. For more information about MSL, see [TB363](#).

Table 1. Key Differences Between Family of Parts

Part Number	Phase Configuration Output X/Output Y/Output Z	Bus Specification Supported	Package
ISL68220	$X+Y \leq 2$	PMBus	QFN 32 Ld, 4x4mm
ISL68221	$X+Y+Z \leq 3$	PMBus	QFN 40 Ld, 5x5mm
ISL68222	$X+Y \leq 5$	PMBus	QFN 40 Ld, 5x5mm
ISL68223	$X+Y \leq 4$	PMBus	QFN 40 Ld, 5x5mm
ISL68224	$X+Y+Z \leq 6$	PMBus	QFN 52 Ld, 6x6mm
ISL68225	$X+Y \leq 9$	PMBus	QFN 52 Ld, 6x6mm
ISL68226	$X+Y+Z \leq 8$	PMBus	QFN 60 Ld, 7x7mm
ISL68227	$X \leq 12$	PMBus	QFN 60 Ld, 7x7mm
ISL68229	$X+Y+Z \leq 12$	PMBus	QFN 68 Ld, 8x8mm
ISL68233	$X+Y \leq 5$	PMBus/AVSBus	QFN 40 Ld, 5x5mm
ISL68236	$X+Y \leq 9$	PMBus/AVSBus	QFN 52 Ld, 6x6mm
ISL68239	$X+Y+Z \leq 12$	PMBus/AVSBus	QFN 68 Ld, 8x8mm

Table 2. Power Stage Recommendations

Part Number	Rating (A)	Type	TOUT	TREF	REFIN	FAULT#	Package Dwg. #	Pin-to-Pin Compatible	Typically Used With
5.0V PWM Power Stage Family									
ISL99227B	60	SPS	Yes	No	Yes	Yes	L32.5x5V	N/A	Phase Doublers: ISL6617A
ISL99360B	60	SPS	Yes	No	Yes	Yes	L32.5x5W	N/A	
3.3V PWM Power Stage Family									
ISL99227	60	SPS	Yes	No	Yes	Yes	L32.5x5V	N/A	Full Digital Controllers: ISL68/69xxx
ISL99360	60	SPS	Yes	No	Yes	Yes	L32.5x5W	N/A	
ISL99380	80	SPS	Yes	No	Yes	No	L39.5x6A	ISL99390	
ISL99390	90	SPS	Yes	No	Yes	No	L39.5x6A	ISL99380	
ISL99392	90	SPS	Yes	Yes	No	Yes	L39.5x6A	N/A	ISL682xx/692xx controllers that support low power state PWM protocol

1.4 Pin Configuration

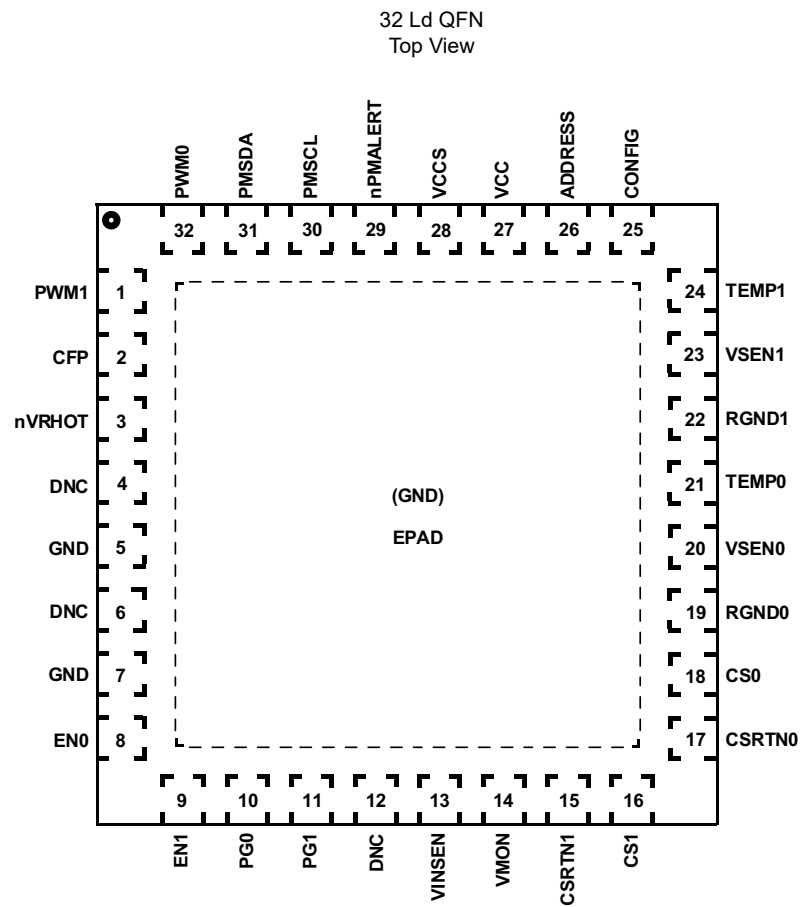

1.5 Functional Pin Descriptions

See [Table 5 on page 29](#) for design layout considerations.

Pin Number	Pin Name	Description
1, 32	PWM [1:0]	Pulse-Width Modulation (PWM) outputs. Connect these pins to the PWM input pins of 3.3V logic-compatible, smart power stages, driver ICs, or DrMOS.
2	CFP	Catastrophic fault protection output. This active, high-logic signal can be configured to alert the host to major fault events.
3	nVRHOT	Thermal warning indicator. This open-drain output is pulled low in the event of a sensed over-temperature at the TEMP pins.
5, 7	GND	Connect to ground.
9, 8	EN [1:0]	Input pin used for enable control of outputs. Connect to ground if not used.
11, 10	PG [1:0]	Open-drain, power-good indicator for outputs.
4, 6, 12	DNC	Do not connect to this pin.
13	VINSEN	Input voltage sense pin for the V_{IN} supply voltage.
14	VMON	Input voltage sense pin for the driver supply voltage.
15, 17	CSRTN [1:0]	The CS and CSRTN pins are current-sense inputs to individual phase differential amplifiers. Unused phases should have their respective current-sense inputs grounded. The CS and CSTRN pins support smart power stage, DCR, and resistor sensing. Connection details depend on the current-sense method chosen.
16, 18	CS [1:0]	
22, 19	RGND [1:0]	Negative differential voltage sense input for outputs. Connect to a negative remote sensing point. Connect to ground if not used.
23, 20	VSEN [1:0]	Positive differential voltage sense input for outputs. Connect to a positive remote sensing point. Connect to ground if not used.
24, 21	TEMP [1:0]	Input pin for sensing external temperature measurement at outputs. Supports NTC-based temperature sensing and smart power stage sensing. Connect to ground if not used.
25	CONFIG	Configuration ID selection pin. Attach a resistor from this pin to GND.
26	ADDRESS	SMBus/PMBus address selection pin.
27	VCC	Chip primary bias input. Connect this pin directly to a +3.3V supply with a 1 μ F or greater MLCC bypass capacitor.
28	VCCS	Internally generated 1.2V LDO logic supply from VCC. Decouple with a 4.7 μ F or greater MLCC (X5R or better).
29	nPMALERT	Open-drain output pin for alerting the SMBus host.
30	PMSCL	Serial clock signal pin for the SMBus interface.
31	PMSDA	Serial data signal pin for the SMBus interface.
EPAD	GND	The package pad serves as the GND return for all IC functions. Connect directly to the system GND plane with multiple vias.

2. Specifications

2.1 Absolute Maximum Ratings

Parameter	Pins	Minimum	Maximum	Unit
Input Voltage Range	VCC		+4.3	V
	VCCS		+1.6	V
	VINSEN	GND - 0.3	18	V
	All Other Pins	GND - 0.3	$V_{CC} + 0.3$	V
ESD Rating	Pins	Value		Unit
Human Body Model (Tested per JS-001-2017)	All Pins	2		kV
Charged Device Model (Tested per JS-002-2014)	All Pins	750		V
Latch-Up (Tested per JESD78E; Class 2, Level A)	All Pins	100		mA

CAUTION: Do not operate at or near the maximum ratings listed for extended periods of time. Exposure to such conditions can adversely impact product reliability and result in failures not covered by warranty.

2.2 Thermal Information

Thermal Resistance (Typical)	θ_{JA} (°C/W)	θ_{JC} (°C/W)
32 Ld 4x4 QFN Package (Notes 4, 5)	38	2.5

Notes:

- θ_{JA} is measured in free air with the component mounted on a high-effective thermal conductivity test board with direct attach features. See [TB379](#).
- For θ_{JC} , the case temperature location is the center of the exposed metal pad on the package underside.

Parameter	Minimum	Maximum	Unit
Maximum Junction Temperature		+150	°C
Maximum Storage Temperature Range	-65	+150	°C
Pb-Free Reflow Profile	see TB493		

2.3 Recommended Operating Conditions

Parameter	Minimum	Maximum	Unit
Supply Voltage, V_{CC}	3.135	3.465	V
Junction Temperature	-40	+125	°C
Output Voltage	0	3.05	V

2.4 Electrical Specifications

Recommended operating conditions, $V_{CC} = 3.3V$, unless otherwise specified. **Boldface limits apply across the operating ambient temperature range -40°C to +85°C.**

Parameter	Test Conditions	Min (Note 7)	Typ	Max (Note 7)	Unit
V_{CC} Supply Current					
Nominal Supply Current	$V_{CC} = 3.3V_{DC}$; $ENx = V_{IH}$, all rails and phases operating, $f_{SW} = 600kHz$		34		mA
Shutdown Supply Current	$V_{CC} = 3.3V_{DC}$; $EN = 0V$, no switching		8		mA
VCCS LDO Supply					
Output Voltage			1.22		V
Maximum Current Capability	Excluding internal load		20		mA
Power-On Reset (POR)					
V_{CC} Brownout Threshold			2.95		V
VCCS Rising POR Threshold			1		V
VCCS Falling POR Threshold			0.9		V
Enable Input High Level (V_{IH})		2			V
Enable Input Low Level (V_{IL})				0.8	V
Configurations Stored in Memory					
Maximum Number of Configurations Stored		28			
Maximum Number of Unique Configurations Stored		16			
POR to Initialization					
POR to Initialization Complete Time			15		ms
Output Voltage Characteristics					
System Accuracy	(Note 6), closed loop V_{OUT} set-point = 1.00V to 3.05V	-0.5		0.5	%
	(Note 6), closed loop V_{OUT} set-point = 0.8V to 0.999V	-5		5	mV
	(Note 6), closed loop V_{OUT} set-point = 0.25V to 0.799V	-8		+8	mV
Voltage Sense Amplifier					
Open Sense Current	Only at VSEN open detection during initialization period		220		μA
Input Impedance (VSEN - RGND)			140		k Ω
Maximum Common-Mode Input			$V_{CC} - 0.2$		V
Differential Input Range (VSEN - RGND)				3.05	V
Output Current-Sense and Overcurrent Protection					
Current-Sense Accuracy	SPS current sensing	-1		1	%
Average Overcurrent Threshold Resolution			0.1		A
Cycle-by-Cycle Current Limiting Threshold Resolution			0.4		A
Digital Droop					
Droop Resolution			0.01		mV/A
Oscillators					
Accuracy of Switching Frequency Setting			± 2		%

Recommended operating conditions, $V_{CC} = 3.3V$, unless otherwise specified. **Boldface limits apply across the operating ambient temperature range -40°C to +85°C. (Continued)**

Parameter	Test Conditions	Min (Note 7)	Typ	Max (Note 7)	Unit
Switching Frequency Range		0.2		2.0	MHz
Soft-Start and V_{OUT} Transition Rates					
Minimum Soft-Start Ramp Rate	Programmable minimum rate		0.01		mV/ μ s
Maximum Soft-Start Ramp Rate	Programmable maximum rate		100		mV/ μ s
Soft-Start Ramp Rate Accuracy			± 2		%
Minimum V_{OUT} Transition Rate			0.01		mV/ μ s
Maximum Fast V_{OUT} Transition Rate			100		mV/ μ s
V_{OUT} Transition Rate Accuracy		-4		4	%
PWM Output (PWM[1:0])					
PWMx Output High Level	$I_{OUT} = 4mA$	$V_{CC} - 0.4$			V
PWMx Output Low Level	$I_{OUT} = 4mA$			0.4	V
PWMx Tri-State Leakage (pin forced high)	$V_{PWM} = V_{CC}$			1	μA
PWMx Tri-State Leakage (pin forced low)	$V_{PWM} = 0V$	-1			μA
Thermal Monitoring and Protection					
Temperature Sensor Range		-50		150	$^{\circ}C$
Temperature Sensor Accuracy	SPS configuration		± 4.5		%
nVRHOT Output Low Impedance			9		Ω
Power-Good and Protection Monitors					
PG Output Low Voltage	$I_{OUT} = 4mA$ load			0.2	V
PG Leakage Current	With pull-up resistor externally connected to VCC		5		μA
Overvoltage Protection Threshold Resolution			1		mV
Undervoltage Protection Threshold Resolution			1		mV
Input Voltage-Sense and Catastrophic Failure Protection (CFP) Output					
Input Voltage Accuracy	VINSEN to ADC accuracy		± 2.5		%
Input Overvoltage Threshold Resolution			16		mV
CFP Output High Voltage	$I_{OUT} = 8mA$	$V_{CC} - 0.4$			V
CFP Output Low Voltage	$I_{OUT} = 8mA$			0.4	V
SMBus/PMBus					
nPMALERT, PMSDA Output Low Level	$I_{OUT} = 20mA$			0.4	V
PMSCL, PMSDA Input High Level		1.35			V
PMSCL, PMSDA Input Low Level				0.8	V
PMSCL, PMSDA Input Hysteresis			80		mV
PMSCL Frequency Range		0.01		2.00	MHz

Notes:

- These parts are designed and adjusted for accuracy with all errors in the voltage loop included. Verified by design and/or characterization.
- Compliance to datasheet limits is assured by one or more methods: production test, characterization, and/or design.

3. Initializing the Device

3.1 Power-On Reset (POR)

ISL68220 initialization begins after V_{CC} crosses its rising POR threshold. When POR conditions are met, basic digital subsystem integrity checks begin. During this process, the controller starts the telemetry subsystem, configures its PMBus address according to the ADDRESS pin resistor value, loads the selected user configuration from NVM as indicated by the CONFIG pin resistor value, checks fault status, and prepares for regulation. The PWM pins are held in tri-state until the device is commanded to regulate. [Figure 3](#) shows the device initialization sequence.

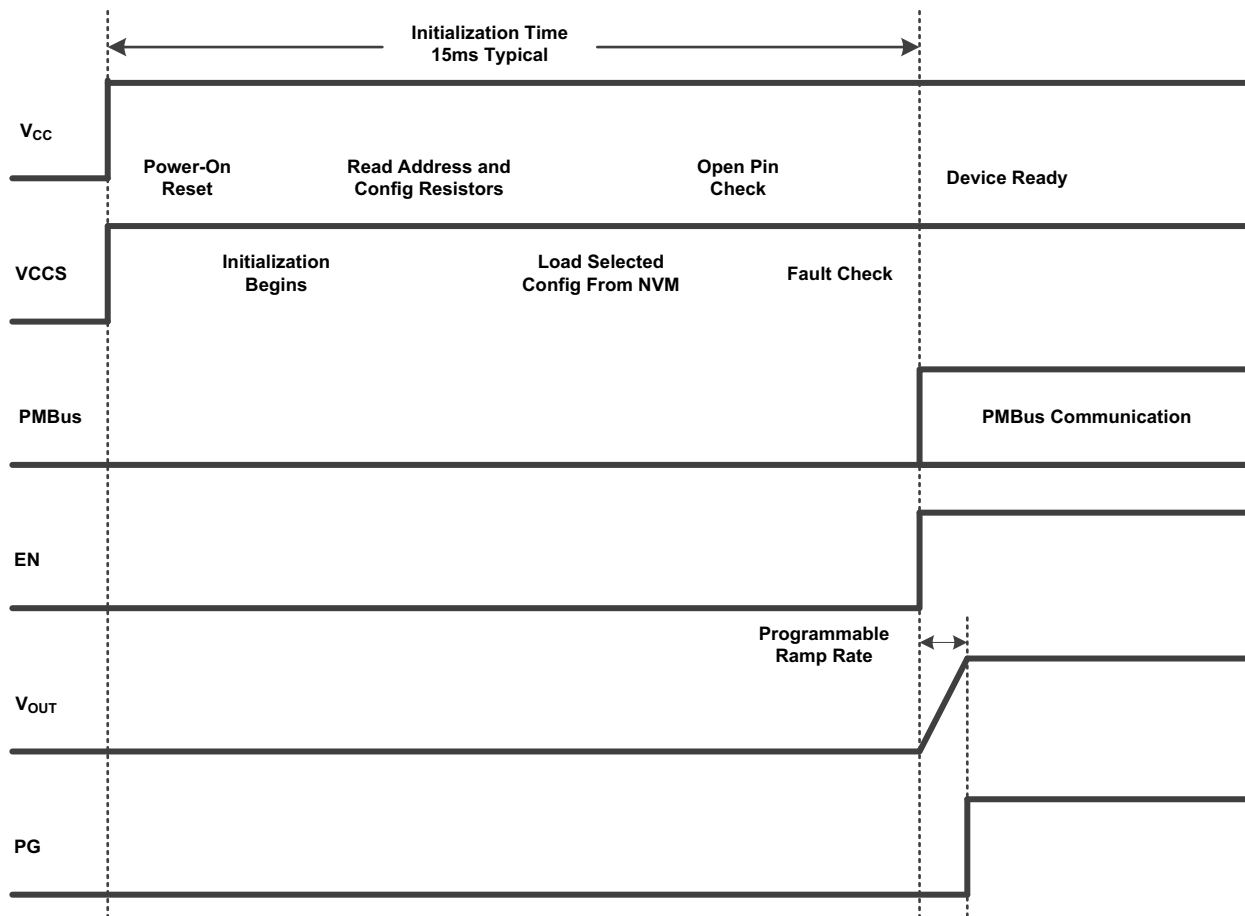

Figure 3. Simplified PMBus Initialization Timing Diagram

3.2 Selecting the PMBus Address

A resistor reader selects the PMBus slave address. The ADDRESS pin reads the value of a resistor connected to GND to determine the PMBus address to use during host communication. [Table 3](#) shows the $R_{ADDRESS}$ values to specify the PMBus slave addresses (7-bit).

Table 3. Resistor Value to PMBus Address Map

R Value (Ω)	PMBus Address	R Value (Ω)	PMBus Address
0	60	5230	51
162	61	5900	52
316	62	6650	53
487	63	7500	54
681	64	8450	55
887	65	9530	56
1130	66	10700	57
1370	67	12100	58
1650	45	13700	59
1960	46	15400	5A
2320	47	17400	5B
2670	4C	19600	5C
3090	4D	22100	5D
3570	4E	24300	5E
4120	4F	27400	5F
4640	50	30100	68

3.3 Selecting the User Configurations

At power-up, a user configuration is loaded for operation. The CONFIG pin reads the value of a resistor connected to GND to determine which user configuration is loaded. The ISL68220 supports 16 distinct configuration identifiers. [Table 4](#) provides the R_{CONFIG} value corresponding to each configuration identifier. A total of 28 one-time programmable non-volatile memory locations are available to store new user configurations or overwrite existing ones. With this flexibility, all 16 unique configurations can be written with 12 available overwrites, one configuration ID can be written up to 28 times, or any combination of configuration IDs can be written until the 28 write limit is reached. Only the most recent configuration for a given configuration ID is loaded. When all 28 memory locations have been written, the ISL68220 no longer accepts attempts to write to NVM. PowerNavigator provides a simple interface to store and load configurations.

Table 4. Resistor Value to CONFIG ID Map

R Value (Ω)	Configuration ID	R Value (Ω)	Configuration ID
0	0	1650	8
162	1	1960	9
316	2	2320	10
487	3	2670	11
681	4	3090	12
887	5	3570	13
1130	6	4120	14
1370	7	4640	15

3.4 Configuring the Device

Configure the ISL68220 to generate a configuration file using PowerNavigator and either directly load to the device RAM or program to the device NVM. During device initialization, the IC attempts to load a configuration from NVM. If no configuration is found, the device remains in a wait state with the PWM pins tri-stated. The device ignores attempts to enable and waits until a configuration is directly loaded using PowerNavigator. The ISL68220 features and functions described in this datasheet are all configured using PowerNavigator. The datasheet provides fundamental understanding of device behavior and design information. Additional details regarding the configuration process is provided in PowerNavigator.

4. Operating the Device

After the ISL68220 initializes and a configuration is loaded, it is ready for operation.

The ISL68220 has several performance enhancing features that enable it to meet the most stringent voltage regulation and efficiency demands. The synthetic current modulator provides excellent transient response to support the latest generation of ASICs and CPUs. Automatic phase dropping, diode emulation, and PFM operation improve efficiency across the load range. The ISL68220 supports Smart Power Stage (SPS) current sense and DCR/resistor current sense to enable optimal design. The device also supports a full complement of high resolution telemetry, including per phase temperature sense when paired with select Renesas SPS devices. The following sections provide more detail about these features.

4.1 Input Voltage Sensing

Input voltage is monitored using the VINSEN pin. Connect the VINSEN pin as shown in [Figure 4](#).

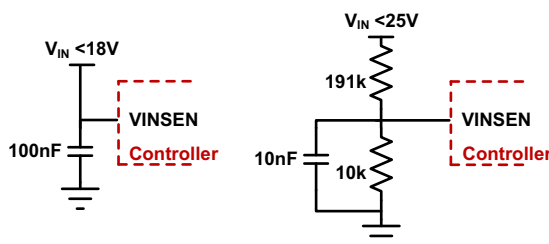

Figure 4. Input Voltage Sense Configuration

Input voltage is monitored continuously, and regulation is stopped anytime the sensed input voltage falls outside the boundaries established by configuration settings associated with the parameters $V_{IN\ ON}$, $V_{IN\ OFF}$, $V_{IN\ Overvoltage\ Fault\ Limit}$, and $V_{IN\ Undervoltage\ Fault\ Limit}$.

4.2 Lossless Input Current and Power Sensing

Input current telemetry is provided per rail using an input current synthesizer. By using the ISL68220's ability to precisely determine its operational conditions, the input current can be synthesized to a high degree of accuracy without the need for a lossy sense resistor. With a precise knowledge of the input current and voltage, the input power can be computed.

4.3 VMON Voltage Sensing

The VMON input pin provides a secondary input voltage sense with several selectable voltage ranges. The VMON input pin can be used to inhibit rail operation when the sensed voltage falls outside the boundary established by the configuration settings that are associated with the parameters $VMON_ON$ and $VMON_OFF$. If a rail is prevented from operating due to a VMON excursion, the rail restarts if the sensed voltage returns to the specified range. Use of this feature is optional for each rail. A typical use case for this voltage sensing feature is monitoring the bias supply voltage associated with the power stages and preventing operation if this voltage is below the configured range. Connection of the VMON pin for sensing the 5V SPS bias voltage is shown in [Figure 5](#).

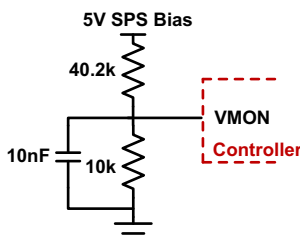

Figure 5. VMON Configuration

4.4 Enabling and Soft-Starting the Device

The ISL68220 outputs are enabled using the enable pin or PMBus. Enable method selection is configured in PowerNavigator on a per-rail basis. When the ISL68220 is commanded to regulate an output, it begins its soft-start sequence. Soft-start moves V_{OUT} smoothly to the programmed voltage. Soft-start timing is programmed using the [TON_DELAY \(60h\)](#) and [TON_RISE \(61h\)](#) PMBus commands.

If a pre-existing voltage bias exists on the output, the PWM signals are held in tri-state until the soft-start ramp reaches the prebias level. The tri-state prevents the converter from sinking current and pulling the prebias down. No special configuration is required to enable this operation.

4.5 Disabling the Device

Similar to the enabling process, outputs can be disabled using the EN pin or PMBus on a per-rail basis. The ISL68220 is configured to disable in two ways:

- **Immediate OFF:** Immediately ceases regulation and tri-state PWM pins
- **Soft OFF:** Actively ramps the output voltage down to 0V before ceasing activity as programmed in [TOFF_DELAY \(64h\)](#) and [TOFF_FALL \(65h\)](#) PMBus commands.

4.6 Phase Configuration and Automatic Phase Dropping

The ISL68220 supports two regulated outputs that control its two phases. Each rail is capable of controlling up to two phases, but the rails can be configured for fewer phases. Unused phases should have their CS and CSRTN pins grounded.

The ISL68220 supports Automatic Phase Dropping (APD) to optimize efficiency across the load range. [Figure 6](#) shows the typical characteristics of efficiency vs load current for a typical multiphase system as the phase count is varied. The diagram shows that optimal efficiency is achieved by using fewer phases as the load current decreases.

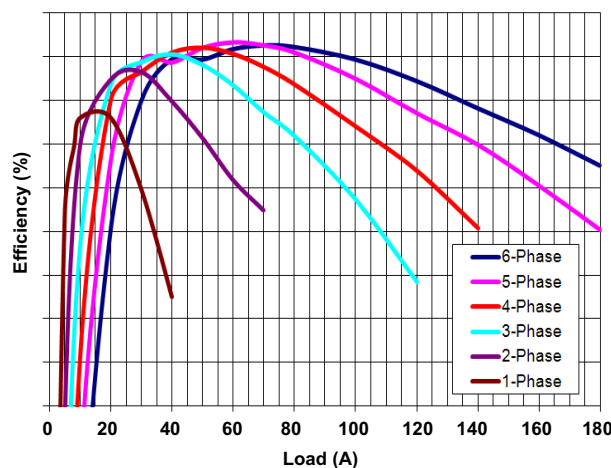

Figure 6. Efficiency vs Phase Number

The ISL68220 continuously monitors output current, and if APD is enabled, the device drops or adds phases from use as the load current varies.

Phases are dropped one at a time with a user-programmed delay between drop events. For example, if the delay is set to 1ms, two phases are active, and the load suddenly drops to a level needing only one phase; the ISL68220 begins by dropping a single phase after 1ms. An additional phase is dropped each millisecond until only one phase remains active. On Rail 0, phases are dropped beginning with the highest assigned phase. On Rail 1, phases are dropped beginning with the lowest assigned phase.

Phases are automatically returned to service when load conditions require more phases. The phases are returned to service in the opposite order they were dropped. Conditions that result in phase adding include increased load current, rapid change sensed on the output voltage, and V_{OUT} transition events. When rapid change is sensed on

the output voltage, the Fast Phase Add function prepares all dropped phases for activation so there is no delay if all phases are needed to support a load transient.

Any command to change the output voltage set point uses all phases, including V_{OUT} transition events. After the output voltage change is complete, phases begin dropping as configured.

To ensure dropped phases have sufficient bootstrap capacitor charge to turn on the high-side MOSFET after a long period of inactivity, a bootstrap refresh function periodically turns on the low-side MOSFET of each dropped phase to refresh the bootstrap capacitor.

To produce the most optimal efficiency across a wide range of output loading, the modulator supports automatic dropping or adding of phases and diode emulation (in a single-phase state). Use of APD and diode emulation are optional. If automatic phase dropping is enabled, the number of active phases at any time is determined solely by load current.

4.7 Diode Emulation and PFM Operation

As described in [“Phase Configuration and Automatic Phase Dropping” on page 18](#), the ISL68220 supports APD to optimize phase usage as load demand decreases. When the regulator drops to 1-phase operation, it supports diode emulation and Pulse Frequency Modulation (PFM) operation to further maximize efficiency. Traditionally, use of such efficiency boosting techniques has come at the expense of transient response, but the ISL68220 is able to meet all transient demands directly from diode emulation/PFM operation.

Diode emulation and PFM operation are supported when a single phase is active. If constant frequency operation is required at light loads, the feature can be disabled. If enabled, the low-side MOSFET conducts when the current is flowing from source-to-drain and does not allow a reverse current, emulating an ideal diode. As [Figure 7](#) shows, when the inductor current is positive, the LGATE is held on and allows the current to flow in the low resistance channel of the LFET. When current reaches 0, the LFET is turned off to prevent a reverse current in the inductor. The controller modulates the LFET state through the PWM pin of the respective regulator channel by tri-stating the PWM when the load current reaches zero, which commands the MOSFET driver to turn off both the HFET and LFET.

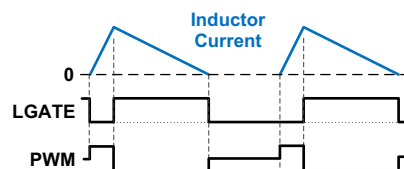

Figure 7. Diode Emulation PWM Signaling

In single-phase diode emulation operation, the ISL68220 delivers inductor current pulses with a user-programmed pulse width. By programming the pulse width, the output voltage ripple can be tuned to meet expectations for any system type. Pulse frequency is then modulated to maintain output voltage regulation, which is depicted in [Figure 8](#). The transition from single phase PFM to multiphase constant frequency operation is managed seamlessly by the ISL68220.

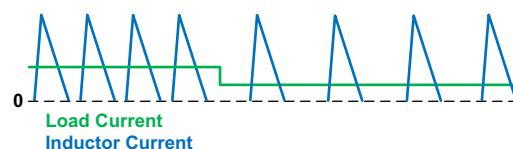

Figure 8. Single-Phase Light Load PFM Operation

4.8 Diode Braking

Applications that support loads with large transient current demands often have significant output voltage overshoot when the load current demand drops suddenly. In some cases, diode braking can allow overshoot reduction at the expense of thermal dissipation in the low-side MOSFET.

4.9 Switching Frequency

Switching frequency is independently programmable on each rail from 200kHz to 2MHz.

4.10 Output Current Sensing

The ISL68220 supports DCR, resistor, and smart power stage current sensing. Use the differential input CS and CSRTN pins to connect to the various sense elements.

4.10.1 SPS Current Sensing

In applications using Smart Power Stage (SPS), the SPS IMON output is connected to the corresponding ISL68220 CSn input. The CSRTNn pins are connected to the SPS current sense reference voltage. For connection details, see the typical application diagram shown in [Figure 1 on page 6](#).

4.10.2 Inductor DCR Sensing

Inductor windings have a resistive component (DCR) that drops a voltage proportional to the inductor current. [Figure 9](#) shows that the DCR is treated as a lumped element with one terminal inaccessible for measurement. Fortunately, a simple R-C network as shown in [Figure 9](#) can reproduce the hidden DCR voltage. By matching the R-C time constant to the L divided by DCR time constant, it is possible to precisely recreate the DCR voltage across the capacitor, so that $V_{DCR}(t) = VC(t)$, preserving even the switching frequency characteristic of the DCR voltage.

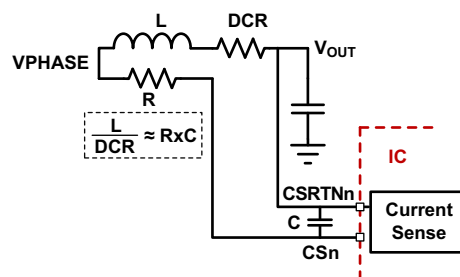

Figure 9. DCR Sensing Configuration

Modern inductors often have such low DCR values that the resulting signal is $<10\text{mV}$. To avoid noise problems, care must be taken in the Printed Circuit Board (PCB) layout to properly place the R-C components and route the differential lines between controller and inductor. [Figure 9](#) shows one PCB design method that places the R component near the inductor VPHASE and the C component very close to the IC pins. The design method maintains isolation of the noisy VPHASE node and maximizes filtering near the IC. Route the lines as a pair on a single layer directly to the controller. Avoid routing the pair near any switching signals such as Phase and PWM. This is the method used by Renesas on evaluation board designs. **Note:** The R component should be 0603 or greater size to limit the effects of voltage coefficient of resistance in the resistor.

Because the DCR is actually the resistance of a metal winding, the DCR value increases with rising temperature. The increase must be compensated or the sensed (and reported) current increases with temperature. To compensate the temperature effect, the ISL68220 provides temperature sensing options and an internal methodology to apply the correction.

4.10.3 Resistive Sensing

For more accurate current sensing, a dedicated current-sense resistor, R_{SENSE} , in series with each output inductor, can serve as the current-sense element. However, this technique reduces the overall converter efficiency due to the additional power loss on the current-sense element, R_{SENSE} .

A current-sensing resistor has a distributed parasitic inductance known as Equivalent Series Inductance (ESL), which is typically less than 4nH. Consider the ESL as a separate lumped quantity, as shown in [Figure 10](#). The phase current, I_L , flowing through the inductor, also passes through the ESL. Similar to DCR sensing described previously, a simple R-C network across the current-sense resistor extracts the R_{SENSE} voltage. Match the ESL/R_{SENSE} time constant to the R-C time constant.

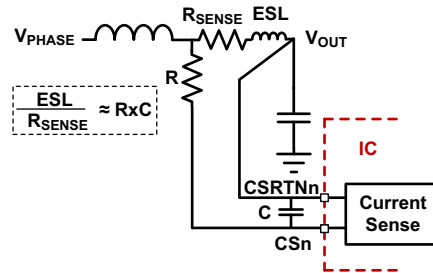

Figure 10. Sense Resistor in Series with Inductor

[Figure 11](#) shows the sensed waveforms with and without matching RC when using resistive sense. PCB layout for resistive sense should follow the guidance described for DCR sense.

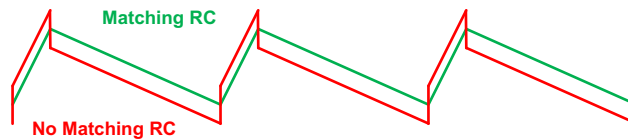

Figure 11. Voltage Across R with and without RC

4.10.4 L/DCR or ESL/R_{SEN} Matching

Assuming the compensator design is correct, [Figure 12](#) shows the expected load transient response waveforms if L/DCR or ESL/R_{SEN} matches the R-C time constant for a droop application. When the load current I_{OUT} has a square change, the output voltage V_{OUT} also has a square response, except for the potential overshoot at load release. However, there is always some uncertainty in the true parameter values involved in the time constant matching so that fine-tuning is generally required.

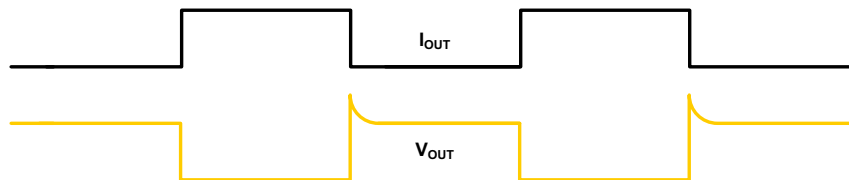

Figure 12. Desired Load Transient Response Waveforms

If the R-C timing constant is too large or too small, $V_C(t)$ does not accurately represent real-time $I_{OUT}(t)$ and worsens the transient response. [Figure 13 on page 22](#) shows the load transient response when the R-C time constant is too small. In this condition, V_{OUT} sags excessively on load insertion and can create a system failure or early overcurrent trip.

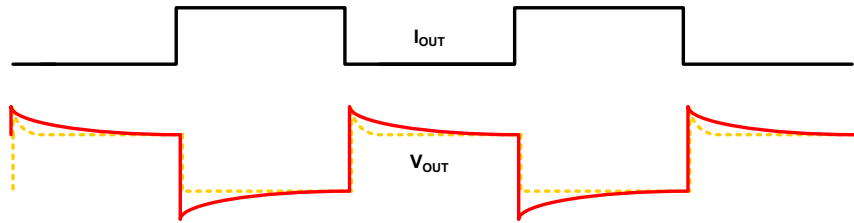

Figure 13. Load Transient Response when R-C Time Constant is Too Small

Figure 14 shows the transient response when the R-C time constant is too large. V_{OUT} is sluggish in drooping to its final value. Use these general guides if fine-tuning is needed.

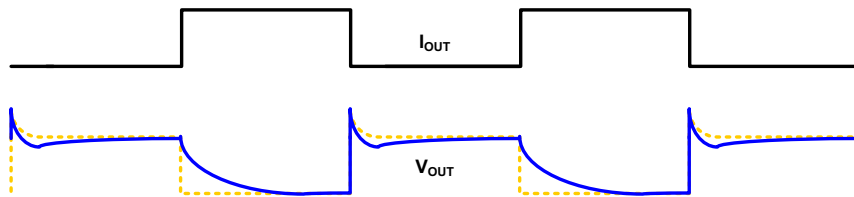

Figure 14. Load Transient Response when R-C Time Constant is Too Large

5. Temperature Sensing

The ISL68220 monitors internal die temperature and supports external per-rail SPS or NTC resistor temperature sense using the TEMPn pins. The controller also offers per-phase temperature sense using the CS and CSRTN pins when paired with select Renesas SPS devices.

5.1 SPS Temperature Sensing

ISL68220 can be configured to sense SPS temperature on a per-rail or per-phase basis. To configure for per-rail temperature sense, connect the TOUT/FLT pin of each SPS in the rail together and tie the net to the ISL68220 TEMPn pin. Select SPS devices also have current sense reference voltage outputs (TREF) that are proportional to temperature. The ISL68220 can be configured to accept this signal and report individual phase temperature. When configured for per-phase temperature sense, the SPS TOUT/FLT pins should remain connected to the ISL68220 TEMPn pin, because the SPS devices report internal fault conditions through the TOUT/FLT pin. See the typical application diagram ([Figure 1 on page 6](#)) for a detailed connection overview of per-rail temperature sense.

5.2 NTC Temperature Sensing

NTC temperature sensing is used in conjunction with inductor DCR output current sensing to sense the inductor temperature. In this configuration, the specified NTC is connected to the IC as shown in [Figure 15](#). To avoid noise problems, route the PCB traces leading to the NTC differentially and keep away from noise sources.

Note: Use the component values shown.

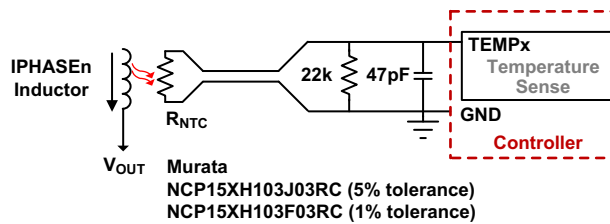

Figure 15. NTC Temperature Sense Connection

When automatic phase dropping is used in a multiphase design, position the NTC close to the phase that runs in single-phase operation. For Rail 0, the correct phase is the lowest phase number assigned to the rail. For Rail 1 and Rail 2, the correct phase is the highest phase number assigned, as shown in [Figure 16](#).

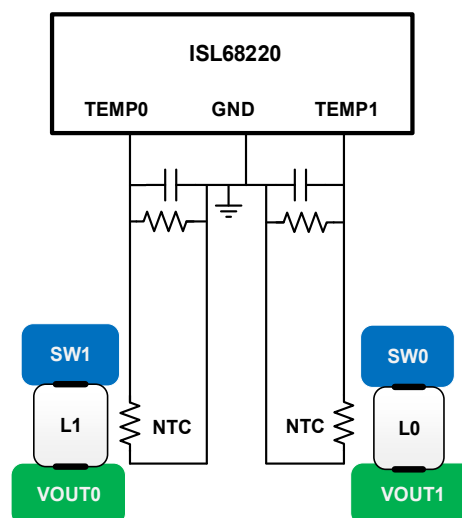

Figure 16. NTC Placement

5.3 Temperature Compensation

The ISL68220 supports temperature compensation to improve the DCR current sense accuracy. Copper wire used to form inductors has a resistivity temperature coefficient of 0.39%/°C. Because the voltage across the inductor is sensed for the output current information, the sensed signal has the same positive temperature coefficient as the inductor DCR.

Compensating current sense for temperature variation requires that the current-sensing element temperature and temperature coefficient are known. Although temperature coefficient is easily obtained, actual current-sense element temperature is difficult to measure directly. Instead an NTC temperature sensor placed near an inductor is measured, and the compensation is applied based on this sensed temperature.

A difference between the sensed temperature and the actual temperature exists, because the temperature sensor is not perfectly coupled to the inductor winding. To accommodate this difference, the ISL68220 allows you to fine-tune temperature compensation for optimal current sense accuracy. For applications requiring the highest current sense accuracy, use SPS current sense.

6. Fault Monitoring and Protection

The ISL68220 includes an extensive fault management system that integrates with high performance host controllers, supporting unprecedented remote system management and debugging capability. If a fault condition occurs, the IC deasserts the PG pin associated with the faulted rail and alerts the host using the PMAAlert pin. You can optionally configure the Catastrophic Failure Protection (CFP) to assert on select faults for additional protection measures at the system level. The ISL68220 also provides Black Box, a recorder with extensive fault logging to support system level debug.

Fault controls are independently enabled and associated fault responses are user configurable. Response type is independently configurable by fault type. Response types supported are:

- **Alert only:** The rail continues to operate.
- **Shut down immediately:** The rail is latched off until commanded on.
- **Shut down and retry with variable retry delay:** The rail attempts to retry indefinitely until the condition clears or the rail is commanded off.

When a fault condition has been declared, clear the fault by issuing a [CLEAR_FAULTS \(03h\)](#) command or by cycling the EN pin of the faulted rail.

6.1 Power-Good Signals

The PG pins are open-drain, power-good outputs that indicate completion of the soft-start sequence and output voltage of the associated rail within the expected regulation range. If a fault occurs, the PG pin of the associated rail is pulled low. PG is also pulled low immediately upon a rail disable.

6.2 Overvoltage/Undervoltage Protection

Output voltage is measured at the load sensing points differentially for regulation, and the same measurement is used for OVP and UVP. [Figure 17](#) shows a simplified OVP/UVP block diagram. The output voltage comparisons are done in the digital domain.

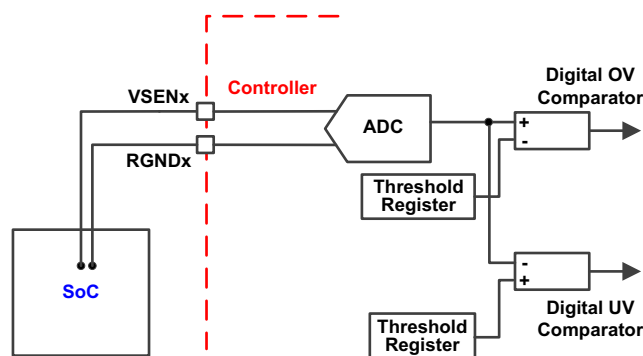

Figure 17. OV/UV Comparators

The device responds to an output overvoltage condition by disabling the output, declaring a fault, setting the PMALERT pin, pulling the PG pin low, and then pulsing the LFET until the output voltage drops below the threshold. Similarly, the device responds to an output undervoltage condition by disabling the output, declaring a fault, setting the PMALERT pin, and pulling the PG pin low. The output does not restart until the EN pin is cycled (unless the device is configured to retry).

The ISL68220 also features open pin sensing protection to detect an open of the output voltage sensing circuit. When this condition is detected, controller operation is suspended.

6.3 Output Overcurrent Protection

The ISL68220 offers a comprehensive overcurrent protection scheme that monitors the total output current, peak phase current, and the valley phase current. The scheme allows you to eliminate inductor saturation and limit the total output current. The ISL68220 supports shutdown and retry response types for OC faults. The response configuration applies to all output current fault mechanisms such as phase peak overcurrent and total output overcurrent.

Figure 18 shows the block diagram of the output overcurrent protection scheme.

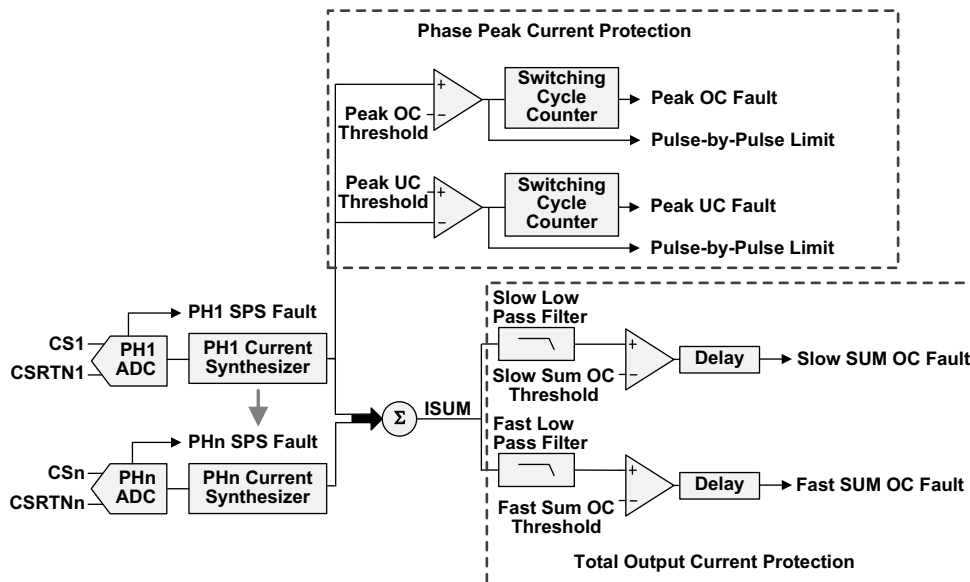

Figure 18. OCP Functional Diagram

Phases are protected from both overcurrent and undercurrent using a pulse-by-pulse scheme that acts instantly on a PWM signal if a detected phase current reaches its threshold. Thresholds for overcurrent and undercurrent allow you to precisely limit phase currents so the inductors never saturate. Phase current limiting behavior can be configured to either shut down the device after a user-determined number of consecutive events or continue indefinitely. If configured to continue indefinitely, the converter behaves much like a current source. Figures 19 and 20 show per-phase current limiting when the device is configured to shut down after a finite number of consecutive events.

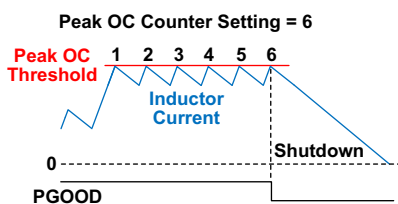

Figure 19. Peak OC Operation

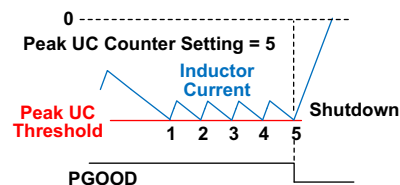

Figure 20. Peak UC Operation

The ISL68220 also supports total output current limits that have user-adjustable response delay. The two sum current limits, fast and slow, allow you to permit high maximum output current for a shorter period of time and lower output current for a longer period. The response delay for the limiting mechanisms is also adjustable. These mechanisms do not restrict the maximum output current until the current has exceeded a threshold for the response delay time. For example, suppose the device is configured with a Fast Sum OC limit of 60A, a response delay of 50µs, and a shutdown response type. Next, suppose a 70A load is then placed on the regulator. 70A is supplied to the load for 50µs, and the device then shuts down as shown in Figure 21.

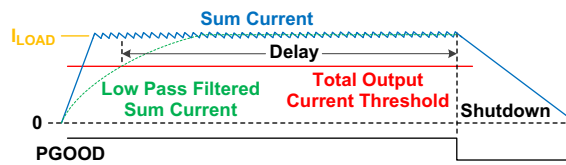

Figure 21. Total Output Current Protection

6.4 Smart Power Stage OC Fault Detect

Renesas Smart Power Stage (SPS) devices output a large signal on their IMON lines if peak current exceeds their preprogrammed threshold; for more details about this functionality, see the relevant SPS datasheet. The ISL68220 detects this fault flag by sensing the signals that exceed the current-sense ADC full scale range and immediately shuts down.

SPS devices that conform to the industry common footprint, such as the ISL99380, do not use the IOOUT pin for signaling overcurrent faults. All faults are signaled using their TOUT/FLT pins, and the ISL68220 provides a detector on each TEMP pin to support this method.

6.5 Thermal Protection and nVRHOT

The ISL68220 supports a comprehensive scheme for thermal alerting and protection. Regardless of the temperature sense method, the device supports over-temperature and under-temperature faults in addition to over-temperature warning. When configured for per phase temperature telemetry, temperature faults are triggered based on the hottest reported phase. For example, if a 2-phase rail with an over-temperature threshold of +110°C reports phase temperatures of +100°C, and +111°C, the device declares a fault because the hottest phase at +111°C exceeds the +110°C fault threshold. When configured for per-phase temperature sense, the SPS TOUT/FLT pins should remain connected to the ISL68220 TEMP pins.

IC die temperature is monitored to support telemetry and thermal shutdown. Shutdown occurs at approximately +130°C.

The nVRHOT pin is used at the system level to inform the powered device to reduce its power consumption. nVRHOT is an open-drain output; an external pull-up resistor is required. This signal is valid only after the controller is enabled. nVRHOT is pulled low when the sensed temperature for any rail reaches the PMBus OT_WARN threshold, providing the powered device with an advance warning of the IC thermal status.

Figure 22 shows the behavior of nVRHOT and an over-temperature fault shutdown.

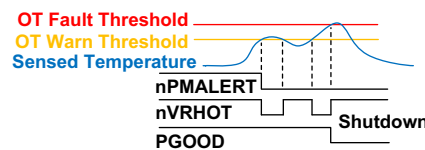

Figure 22. nVRHOT and Over-Temperature Shutdown

6.6 Catastrophic Failure Protection

The CFP pin supports Catastrophic Failure Protection (CFP) functionality. The pin can be configured to activate in the event of a catastrophic fault detection. The function is typically used to immediately disable the input supply to protect the entire system. The CFP function can be configured to respond to output overvoltage, input overvoltage, and/or output overcurrent faults.

6.7 Black Box Recorder

Black Box is a powerful diagnostic tool that captures all telemetry and status information when any fault occurs. The ISL68220 continuously monitors all rail and phase information along with the time duration for which the rail has been regulating, and the tool captures that data when a fault is registered. The tool reports the first fault bit that occurred to cause the shutdown. This diagnostic data is stored in RAM, and Black Box can be configured to additionally write to NVM for retrieval when the system loses input power as a fault occurs. The RAM record is updated every time a fault occurs. Black Box can write to NVM up to 10 times and provides an option to limit NVM writing to once per power cycle to avoid filling up the available NVM space inadvertently.

7. Layout and Design Considerations

The following layout and design strategies help minimize noise coupling and the impact of board parasitic impedances on converter performance, and they optimize the heat dissipating capabilities of the Printed Circuit Board (PCB). Follow these practices during the layout and design process.

7.1 Pin Noise Sensitivity, Design, and Layout Considerations

[Table 5](#) provides general guidance on best practices related to pin noise sensitivity. Use of good engineering judgment is required to implement designs based on criteria specific to the situation.

Table 5. Pin Design and/or Layout Considerations

Pin Name	Noise Sensitive	Description
VINSEN	Yes	Filter VINSEN with 100nF capacitor when sensing VIN directly. Use 10nF when using a resistor divider.
RGNDx VSENx	Yes	Treat each of the remote voltage sense pairs as differential signals in the PCB layout. Route them side by side on the same layer. Do not route them in proximity to noisy signals like PWM or Phase. Place a 3.3nF capacitor across the signals directly at the pins on the top layer.
PGx	No	Open-drain. Avoid setting its pull-up higher than VCC. Tie it to ground when not used.
PMSCL, PMSDA, nPMALERT	Yes	50kHz to 2MHz signals should pair up with nPMALERT and be routed carefully between devices and back to the host. Provide 20 mils of spacing within PMSDA, nPMALERT and PMSCL, and more than 30 mils to all other signals. See the SMBus design guidelines and place proper terminated (pull-up) resistance for impedance matching. Tie to ground when not used. Pull up to 3.3V max.
TEMPx	Yes	While using SPS, place a filter capacitor no greater than 500pF between each TEMP pin and ground near the IC. While using NTC, place a 47pF capacitor and a 22k resistor near the IC and route a differential signal pair from there to the remote NTC. Use Murata NCP15XH103J03RC (5% tolerance) or NCP15XH103F03RC (1% tolerance). Tie to ground if not used.
nVRHOT	No	Open drain. Avoid setting its pull-up rail higher than VCC.
VCC	Yes	Place a 1μF MLCC decoupling capacitor (X5R or better) directly at the pin.
VCCS	Yes	Place a 4.7μF MLCC decoupling capacitor (X5R or better) directly at the pin.
PWMx	No	Avoid routing near noise sensitive analog lines such as current sense or voltage sense. Leave floating if not used.
CSx CSRTNx	Yes	Treat each of the current sense pairs as differential signals in the PCB layout. Route them side by side on the same layer. Do not route them in close proximity to noisy signals like PWM or Phase. Proper routing of current sense is perhaps the most critical of all the layout tasks. Place the R-C filter between CSx and CSRTNx at the controller for SPS configuration.
GND	Yes	This EPAD is the ground for all IC signals. Use four or more vias to directly connect the EPAD to the ground plane. Never use only a single via or a 0Ω resistor connection to the power ground plane. Split ground planes are not advised.
General Comments		The layer next to the top or bottom layer should be a ground layer. The signal layers should be sandwiched between the ground layers if possible.

8. PMBus Protocol

The PMBus Protocol includes the Send Byte, the Write Byte/Word, Read Byte/Word, Group Command, and Alert Response Address protocols.

PMBus Protocol Legend

- S: Start Condition
- A: Acknowledge ("0")
- N: Not Acknowledge ("1")
- W: Write ("0")
- RS: Repeated Start Condition
- R: Read ("1")
- PEC: Packet Error Checking
- P: Stop Condition
- Acknowledge or DATA from Slave, Controller

8.1 Send Byte Protocol

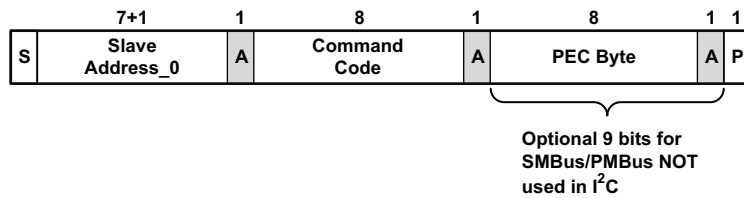

Example command: 03h Clear Faults
 (This clears all of the bits in Status Byte for the selected rail)

Figure 23. Send Byte Protocol

8.2 Write Byte/Word Protocol

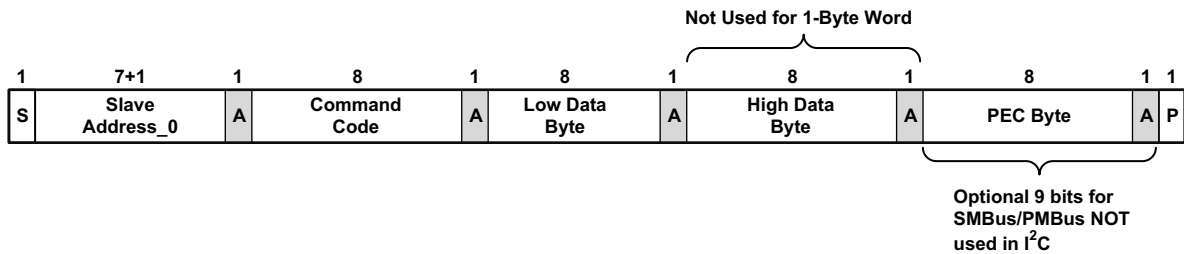

Example command: 21h VOUT_COMMAND

Figure 24. Write Byte/Word Protocol

8.3 Read Byte/Word Protocol

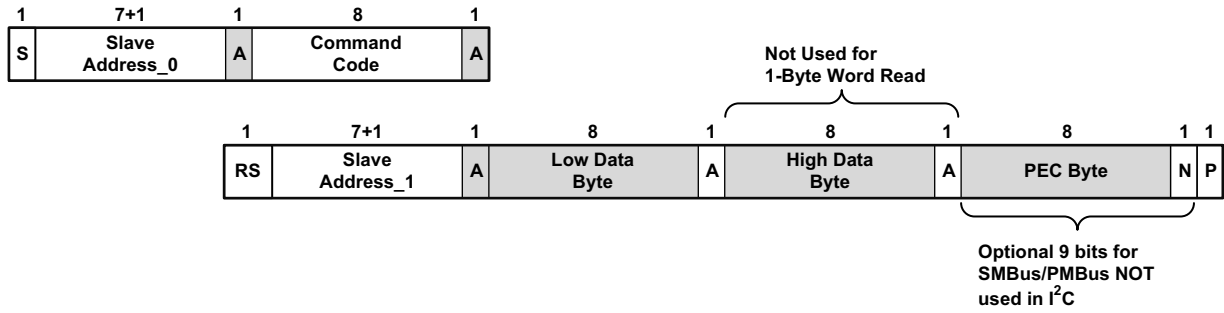

Example command: 8B READ_VOUT (Two words, read voltage of the selected rail).

Note: The STOP (P) bit is NOT allowed before the repeated START condition when reading contents of a register.

Figure 25. Read Byte/Word Protocol

8.4 Group Command Protocol

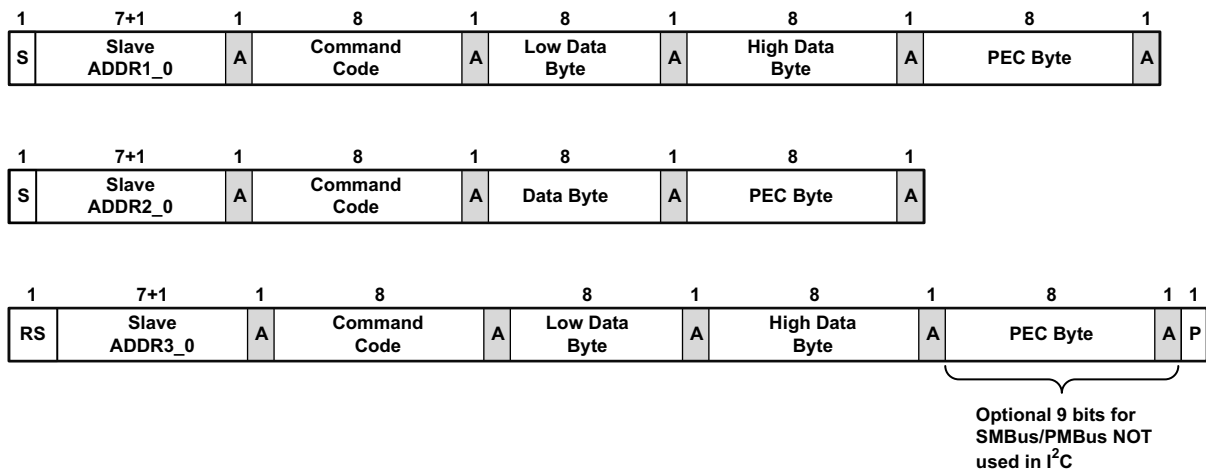

Note: No more than one command can be sent to the same Address

Figure 26. Group Command Protocol

8.5 Alert Response Address

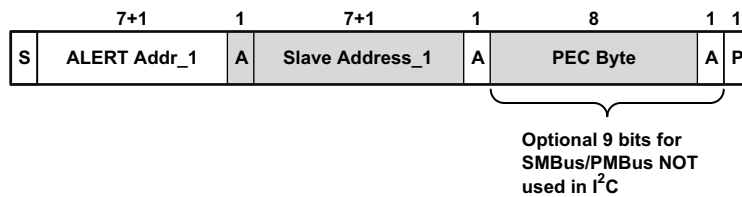

Figure 27. Alert Response Address (ARA, 0001_1001, 25h) for SMBus and PMBus

9. PMBus Commands Summary

Code	Command Name	Description	Type	Data Format	Default Value	Default Setting
00h	PAGE (00h)	Rail selector	R/W	Bit	00h	Page0
01h	OPERATION (01h)	Enable/disable, V _{OUT} source	R/W	Bit	08h	Immediate off, act on fault
02h	ON_OFF_CONFIG (02h)	On/off configuration settings	R/W	Bit	17h	ENABLE pin control, active high, immediate off
03h	CLEAR_FAULTS (03h)	Clears all fault bits in all registers and releases the nPMALERT pin	Write	N/A	N/A	N/A
04h	PHASE (04h)	Phase selector	R/W	Direct	00h	Phase 0
05h	PAGE_PLUS_WRITE (05h)	Allows page and command write in single transaction	Block Write	Bit	N/A	N/A
06h	PAGE_PLUS_READ (06h)	Allows page and command read in single transaction	Block Write/read/process call	N/A	N/A	N/A
10h	WRITE_PROTECT (10h)	Write protection to sets of commands	R/W	Bit	00h	No write protection
19h	CAPABILITY (19h)	Reports PMBus capability	Read	Bit	D0h	See detail
1Bh	SMBALERT_MASK (1Bh)	Mask status bits from SMBALERT signal	Block R/W	Bit	00h	No bits masked
20h	VOUT_MODE (20h)	Defines format for output voltage related commands	Read	Bit	40h	Direct format
21h	VOUT_COMMAND (21h)	Output voltage set by PMBus	R/W	Direct	0384h	900mV
22h	VOUT_TRIM (22h)	Applies trim voltage to V _{OUT} set-point	R/W	Direct	0000h	0mV
23h	VOUT_CAL_OFFSET (23h)	Applies offset voltage to V _{OUT} set-point	R/W	Direct	0000h	0mV
24h	VOUT_MAX (24h)	Absolute maximum voltage setting	R/W	Direct	0BEAh	3050mV
25h	VOUT_MARGIN_HIGH (25h)	Sets voltage target during margin high	R/W	Direct	03B1	945mV
26h	VOUT_MARGIN_LOW (26h)	Sets voltage target during margin low	R/W	Direct	0357	855mV
27h	VOUT_TRANSITION_RATE (27h)	Slew rate setting for V _{OUT} ramp	R/W	Direct	09C4h	25mV/μs
28h	VOUT_DROOP (28h)	Sets the load-line (V/I slope) resistance for the output	R/W	Direct	0000h	0μV/A
2Bh	VOUT_MIN (2Bh)	Absolute minimum voltage setting	R/W	Direct	0000h	0mV
33h	FREQUENCY_SWITCH (33h)	Sets PWM switching frequency	R/W	Direct	0258h	600kHz
34h	POWER_MODE (34h)	Sets the power conversion mode	R/W	Bit	03h	Maximum power
35h	VIN_ON (35h)	Sets the V _{IN} startup threshold	R/W	Direct	02BCh	7V
36h	VIN_OFF (36h)	Sets the V _{IN} shutdown threshold	R/W	Direct	01F4h	5V
40h	VOUT_OV_FAULT_LIMIT (40h)	Sets the V _{OUT} OV fault limit	R/W	Direct	0C1Ch	3100mV
41h	VOUT_OV_FAULT_RESPONSE (41h)	Configures the V _{OUT} OV fault response	R/W	Bit	84h	Latch off

Code	Command Name	Description	Type	Data Format	Default Value	Default Setting
44h	VOUT_UV_FAULT_LIMIT (44h)	Sets the V_{OUT} UV fault limit	R/W	Direct	0000h	0mV
45h	VOUT_UV_FAULT_RESPONSE (45h)	Configures the V_{OUT} UV fault response	R/W	Bit	84h	Latch off
46h	IOUT_OC_FAULT_LIMIT (46h)	Sets the I_{OUT} OC fault limit	R/W	Direct	12Ch	30A
47h	IOUT_OC_FAULT_RESPONSE (47h)	Configures the I_{OUT} OC fault response	R/W	Bit	C4h	Latch off
4Fh	OT_FAULT_LIMIT (4Fh)	Sets the OT fault limit	R/W	Direct	007Dh	125°C
50h	OT_FAULT_RESPONSE (50h)	Configures the OT fault response	R/W	Bit	84h	Latch off
51h	OT_WARN_LIMIT (51h)	Sets the OT warn limit	R/W	Direct	006Eh	110°C
53h	UT_FAULT_LIMIT (53h)	Sets the UT fault limit	R/W	Direct	FFD8h	-40°C
54h	UT_FAULT_RESPONSE (54h)	Configures the UT fault response	R/W	Bit	80h	Latch off
55h	VIN_OV_FAULT_LIMIT (55h)	Sets the V_{IN} OV fault limit	R/W	Direct	0640h	16V
56h	VIN_OV_FAULT_RESPONSE (56h)	Configures the V_{IN} OV fault response	R/W	Bit	84h	Latch off
57h	VIN_OV_WARN_LIMIT (57h)	Sets the V_{IN} OV warn limit	R/W	Direct	0708h	18V
58h	VIN_UV_WARN_LIMIT (58h)	Sets the V_{IN} UV warn limit	R/W	Direct	0000h	0mV
59h	VIN_UV_FAULT_LIMIT (59h)	Sets the V_{IN} UV fault limit	R/W	Direct	0000h	0mV
5Ah	VIN_UV_FAULT_RESPONSE (5Ah)	Configures the V_{IN} UV fault response	R/W	Bit	84h	Latch off
5Bh	IIN_OC_FAULT_LIMIT (5Bh)	Sets the I_{IN} OC fault limit	R/W	Direct	1388h	50A
5Ch	IIN_OC_FAULT_RESPONSE (5Ch)	Configures the I_{IN} OC fault response	R/W	Bit	04h	Ignore
5Dh	IIN_OC_WARN_LIMIT (5Dh)	Sets the I_{IN} OC warn limit	R/W	Direct	3A98h	150A
60h	TON_DELAY (60h)	Sets turn on delay time	R/W	Direct	0000h	0 μ s
61h	TON_RISE (61h)	Sets turn on rise time	R/W	Direct	01F4h	500 μ s
64h	TOFF_DELAY (64h)	Sets turn off delay time	R/W	Direct	0000h	0 μ s
65h	TOFF_FALL (65h)	Sets turn off fall time	R/W	Direct	01F4h	500 μ s
78h	STATUS_BYTE (78h)	First byte of STATUS_WORD	Read	Bit	N/A	N/A
79h	STATUS_WORD (79h)	Summary of critical faults	Read	Bit	N/A	N/A
7Ah	STATUS_VOUT (7Ah)	Reports V_{OUT} warnings/faults	Read	Bit	N/A	N/A
7Bh	STATUS_IOUT (7Bh)	Reports I_{OUT} warnings/faults	Read	Bit	N/A	N/A
7Ch	STATUS_INPUT (7Ch)	Reports input warnings/faults	Read	Bit	N/A	N/A
7Dh	STATUS_TEMPERATURE (7Dh)	Reports temperature warnings/faults	Read	Bit	N/A	N/A
7Eh	STATUS_CML (7Eh)	Reports communication, memory, logic errors	Read	Bit	N/A	N/A
80h	STATUS_MFR_SPECIFIC (80h)	Reports other specific faults	Read	Bit	N/A	N/A
88h	READ_VIN (88h)	Reports input voltage measurement	Read	Direct	N/A	mV
89h	READ_IIN (89h)	Reports input current measurement	Read	Direct	N/A	A
8Bh	READ_VOUT (8Bh)	Reports output voltage measurement	Read	Direct	N/A	mV

Code	Command Name	Description	Type	Data Format	Default Value	Default Setting
8Ch	READ_IOUT (8Ch)	Reports output current measurement	Read	Direct	N/A	A
8Dh	READ_TEMPERATURE_1 (8Dh)	Reports power stage temperature measurement	Read	Direct	N/A	°C
8Eh	READ_TEMPERATURE_2 (8Eh)	Reports internal temperature measurement	Read	Direct	N/A	°C
8Fh	READ_TEMPERATURE_3 (8Fh)	Reports TEMP pin temperature measurement	Read	Direct	N/A	°C
96h	READ_POUT (96h)	Reports output power	Read	Direct	N/A	W
97h	READ_PIN (97h)	Reports input power	Read	Direct	N/A	W
98h	PMBUS_REVISION (98h)	Reports the PMBus revision used	Read	Bit	33h	P1 R1.3, P2 R1.3
99h	MFR_ID (99h)	Stores inventory information	Block R/W	Bit	00000000h	Empty
9Ah	MFR_MODEL (9Ah)	Stores inventory information	Block R/W	Bit	00000000h	Empty
9Bh	MFR_REVISION (9Bh)	Stores inventory information	Block R/W	Bit	00000000h	Empty
9Dh	MFR_DATE (9Dh)	Stores inventory information	Block R/W	Bit	00000000h	Empty
ADh	IC_DEVICE_ID (ADh)	Reports device identification information	Block Read	Bit	49D26300h	49D26300h
A Eh	IC_DEVICE_REV (A Eh)	Reports device revision information	Block Read	Bit		Release revision
C5h	DMAFIX (C5h)	Fixed DMA transactions	R/W	Bit	0000h	0
C6h	DMASEQ (C6h)	Sequential DMA transaction	R/W	Bit	0000h	0
C7h	DMAADDR (C7h)	Sets the address for DMA transactions	R/W	Bit	0000h	0
CDh	PEAK_OC_LIMIT (CDh)	Sets peak per phase OC limit	R/W	Direct	258h	60A
CEh	PEAK_UC_LIMIT (CEh)	Sets peak per phase UC limit	R/W	Direct	FDA8	-60A
D0h	VMON_ON (D0h)	Sets the VMON startup threshold	R/W	Direct	1C2h	4500mV
D1h	VMON_OFF (D1h)	Sets the VMON shutdown threshold	R/W	Direct	190h	4000mV
DDh	COMPPROP (DDh)	Configures proportional gain	R/W	Bit	D90907C4	See detail
DEh	COMPINTEG (DEh)	Configures integral gain	R/W	Bit	A9h	See detail
DFh	COMPIDFF (DFh)	Configures differential gain	R/W	Bit	0h	See detail
E0h	COMPCFB (E0h)	Configures AC current feedback	R/W	Bit	560h	See detail
E3h	HS_BUS_CURRENT_SCALE (E3h)	Sets the high speed bus current scaling	R/W	Bit	4000h	1.0
E4h	PHASE_CURRENT (E4h)	Reports per-phase current	Read	Direct	N/A	A
E5h	PHASE_TEMPERATURE (E5h)	Reports per-phase temperature	Read	Direct	N/A	°C
E9h	PEAK_OCUC_COUNT (E9h)	Sets the count limit before fault	R/W	Bit	606h	6 cycles for OC & UC
E Ah	SLOW_IOUT_OC_LIMIT (E Ah)	Sets the slow I _{OUT} OC limit	R/W	Direct	C8h	20A
EBh	FAST_OC_FILT_COUNT (EBh)	Configures the fast OC filter	R/W	Bit	0696h	Filter = 10.7µs, Delay = 100µs
ECh	SLOW_OC_FILT_COUNT (ECh)	Configures the slow OC filter	R/W	Bit	0606h	Filter = 10.7µs, Delay = 1024µs

Code	Command Name	Description	Type	Data Format	Default Value	Default Setting
F0h	LOOPCFG (F0h)	Defines rail operating configuration	R/W	Bit	102031F6h	See detail
F2h	RESTORE_CFG (F2h)	Identifies configuration to be restored from NVM	R/W	Bit	00h	

9.1 PMBus Use Guidelines

All commands can be read at any time.

9.2 PMBus Data Formats

9.2.1 Direct

The Direct data format is a 2-byte binary integer.

9.2.2 Linear 16 Unsigned (L16U)

The L16u data format uses a fixed exponent (hard-coded to $N = -9h$) and a 16-bit unsigned integer mantissa (Y) to represent the real world decimal value (X). The relation between the real world decimal value (X), N, and Y is: $X = Y \cdot 2^{-9}$.

9.2.3 Linear 16 Signed (L16S)

The L16S data format uses a fixed exponent (hard-coded to $N = -9h$) and a 16-bit signed integer mantissa (Y) to represent the real world decimal value (X). The relation between the real world decimal value (X), N, and Y is: $X = Y \cdot 2^{-9}$.

9.2.4 Linear 11 (L11)

The L11 data format uses 5-bit two's complement exponent (N) and 11-bit two's complement mantissa (Y) to represent the real world decimal value (X).

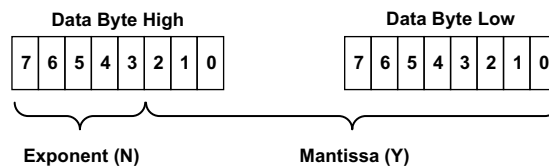

Figure 28. Linear 11 Data Format

The relation between the real world decimal value (X), N, and Y is: $X = Y \cdot 2^N$.

9.2.5 Bit Field (Bit)

A description of Bit Field is provided in the [“PMBus Command Detail” on page 36](#).

9.2.6 Custom (Cus)

Custom format

10. PMBus Command Detail

10.1 PAGE (00h)

Definition: Selects the communication path to Rail 0, Rail 1, both rails, or individual phases. All paged commands following this command are received and acted on by the selected destination path. Paged commands that can be written can be written globally, but can only be read on a specific page unless otherwise specified. Global commands remain global regardless of the value of this command. Individual phase access is available by setting this command to 80h and setting the individual phase value using the PHASE command.

Access: Global

Data Length in Bytes: 1

Data Format: Bit Field

Type: R/W

Default Value: 00h

Command	PAGE (00h)							
Format	Bit Field							
Bit Position	7	6	5	4	3	2	1	0
Access	R/W	R/W	R/W	R/W	R/W	R/W	R/W	R/W
Function	See Following Table							
Default Value	0	0	0	0	0	0	0	0

Bit Value	Setting
00h	Page 0 (Rail 0)
01h	Page 1 (Rail 1)
80h	Individual phase (set by the PHASE command)
FFh	Global (All Rails)

10.2 OPERATION (01h)

Definition: Sets Enable/Disable state when configured for PMBus enable. Sets the source of the target V_{OUT} . The following table reflects the valid settings for the device.

Access: Paged

Data Length in Bytes: 1

Data Format: Bit Field

Type: R/W

Default Value: 08h (Immediate off, Act on fault)

Command	OPERATION (01h)							
Format	Bit Field							
Bit Position	7	6	5	4	3	2	1	0
Access	R/W	R/W	R/W	R/W	R/W	R/W	R/W	R/W
Function	See Following Table							
Default Value	0	0	0	0	1	0	0	0

Bit Number	Purpose	Bit Value	Meaning
7	Enable/Disable Output	0	Disable
		1	Enable
6	Disable by PMBus Behavior	0	Immediate off (decay with PWM tri-state)
		1	Soft off (Use TOFF_DELAY and TOFF_FALL)
5:4	V_{OUT} Source	00	$V_{OUT_COMMAND}$
		01	$V_{OUT_MARGIN_LOW}$
		10	$V_{OUT_MARGIN_HIGH}$
		11	Not used
3:2	Margin Response	01	Ignore V_{OUT} OV, UV faults when margined.
		10	Act on V_{OUT} OV, UV faults when margined.
1	Not Supported	0	Not supported
0	Not Supported	X	Not supported

10.3 ON_OFF_CONFIG (02h)

Definition: Configures the interpretation and coordination of the OPERATION command and the ENABLE pin.

Access: Paged

Data Length in Bytes: 1

Data Format: Bit Field

Type: R/W

Default Value: 17h (ENABLE pin control)

Command	ON_OFF_CONFIG (02h)							
Format	Bit Field							
Bit Position	7	6	5	4	3	2	1	0
Access	R/W	R/W	R/W	R/W	R/W	R/W	R/W	R/W
Function	See Following Table							
Default Value	0	0	0	1	0	1	1	1

Bit Number	Purpose	Bit Value	Meaning
7:5	Not Supported	000	Not supported
4:2	Sets the source of enable	0XX	Output enables any time power is present regardless of pin or OPERATION command state.
		101	Output enables from the enable pin only.
		110	Output enables from the OPERATION command only.
		111	Output enables from the enable pin AND the OPERATION command. Both must be set to enable.
1	Polarity of ENABLE pin	0	Active low
		1	Active high
0	ENABLE pin action when commanding the unit to turn off	0	Use the configured TOFF_DELAY and TOFF_FALL settings.
		1	Turn off the output immediately (decay with PWM tri-state).

10.4 CLEAR_FAULTS (03h)

Definition: Clears all fault status bits in all registers and releases the nPMALERT pin (if asserted) simultaneously. If a fault condition still exists, the bit(s) reasserts immediately. This command does not restart a device if it is shut down, it only clears the faults.

Access: Paged

Data Length in Bytes: 0

Data Format: N/A

Type: Write only

10.5 PHASE (04h)

Definition: Sets the individual phase address for reading from PHASE_CURRENT (E4h) and PHASE_TEMPERATURE (E5h). The PAGE command must also be set to access phase information.

Access: Global

Data Length in Bytes: 1

Data Format: Direct

Type: R/W

Default Value: 00h (phase 0)

Equation: PHASE = (direct value)

Range: Phase 0 to 1

Command	PHASE (04h)							
Format	Direct							
Bit Position	7	6	5	4	3	2	1	0
Access	R/W	R/W	R/W	R/W	R/W	R/W	R/W	R/W
Function	Unsigned Integer							
Default Value	0	0	0	0	0	0	0	0

10.6 PAGE_PLUS_WRITE (05h)

Definition: Sets the page within a device, sends a command, and sends the data for the command in one packet.

Access: Global

Data Format: Bit Field

Type: Block Write

The PAGE_PLUS_WRITE command uses the WRITE BLOCK protocol.

Figure 29 shows an example of the PAGE_PLUS command being used to send a command that has two data bytes to be written and a PEC byte.

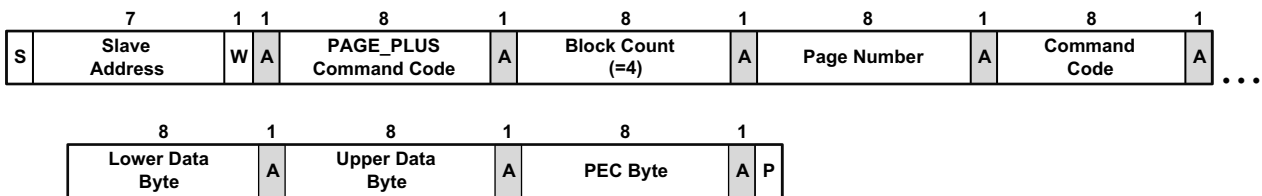

Figure 29. PAGE_PLUS_WRITE Command with a PEC Byte

10.7 PAGE_PLUS_READ (06h)

Definition: Sets the page within a device, sends a command, and reads the data returned by the command in one packet.

Access: Paged

Data Format: Bit Field

Type: Block Read

The PAGE_PLUS_READ command uses the BLOCK WRITE – BLOCK READ PROCESS CALL protocol.

Figure 30 shows an example of the PAGE_PLUS command being used to send a command that has two data bytes to be read and a PEC byte.

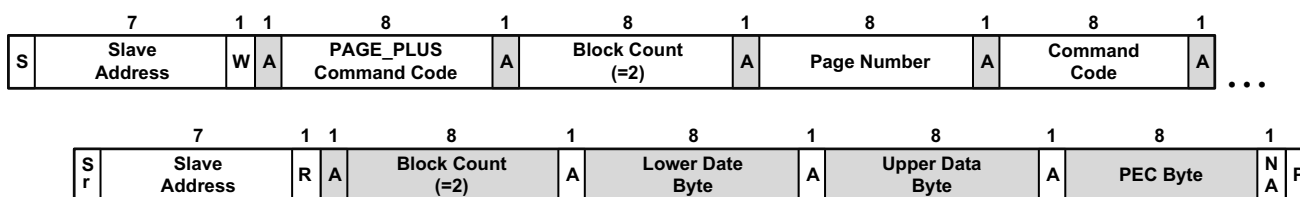

Figure 30. PAGE_PLUS_READ Command with a PEC Byte

10.8 WRITE_PROTECT (10h)

Definition: Sets the write protection of certain configuration commands.

Access: Global

Data Length in Bytes: 1

Data Format: Bit Field

Type: R/W

Default Value: 00h (enable all writes)

Command	WRITE_PROTECT (10h)							
Format	Bit Field							
Bit Position	7	6	5	4	3	2	1	0
Access	R/W	R/W	R/W	R/W	R/W	R/W	R/W	R/W
Function	See Following Table							
Default Value	0	0	0	0	0	0	0	0

Bits 7:0	Protection
1000 0000	Disable all writes except to WRITE_PROTECT command.
0100 0000	Disable all writes except to WRITE_PROTECT, OPERATION, and PAGE.
0010 0000	Disable all writes except to WRITE_PROTECT, OPERATION, PAGE, ON_OFF_CONFIG, and VOUT_COMMAND.
0000 0010	Disable all writes except to WRITE_PROTECT, OPERATION, PAGE, ON_OFF_CONFIG, VOUT_COMMAND, and DMA.
0000 0000	Enable all writes

Note: Any settings other than the five shown results in an invalid data fault.

10.9 CAPABILITY (19h)

Definition: Reports PMBus capabilities of the device.

Access: Global

Data Length in Bytes: 1

Data Format: Bit Field

Type: Read Only

Default Value: D0h (PEC supported, bus speed 1MHz, SMBALERT supported, Linear/Direct numeric data)

Command	CAPABILITY (19h)							
Format	Bit Field							
Bit Position	7	6	5	4	3	2	1	0
Access	R	R	R	R	R	R	R	R
Function	See Following Table							
Default Value	1	1	0	1	0	0	0	0

Bit Number	Purpose	Bit Value	Meaning
7	PEC Support	1	PEC supported
		0	PEC not supported
6:5	Maximum Bus Speed	11	Not supported
		10	1MHz
		01	400kHz
		00	100kHz
4	SMBALERT Support	1	SMBALERT pin and response protocol is supported.
		0	SMBALERT pin and response protocol is not supported.
3	Numeric Format	1	Numeric data, IEEE half precision floating point format
		0	Numeric data, Linear/Direct
2	Not Supported	0	Not supported
1:0	Not Supported	00	Not supported

10.10 SMBALERT_MASK (1Bh)

Definition: Prevents a warning or fault condition from asserting the SMBALERT# signal. Can be used on the following PMBus status commands: STATUS_VOUT, STATUS_IOUT, STATUS_INPUT, STATUS_TEMPERATURE, STATUS_CML, and STATUS_MFR_SPECIFIC.

Access: Paged

Data Format: Bit Field

Type: Block R/W

The command format used to block a status bit or bits from causing the SMBALERT# signal to be asserted is shown in [Figures 31](#) and [32](#). The bits in the mask byte align with the bits in the corresponding status register. For example, if the STATUS_TEMPERATURE command code is sent with the mask byte 01000000b, an over-temperature warning condition would be blocked from asserting SMBALERT#.

Note: [Figure 31](#) shows the command format used by the host to determine the SMBALERT_MASK setting for a given status register.

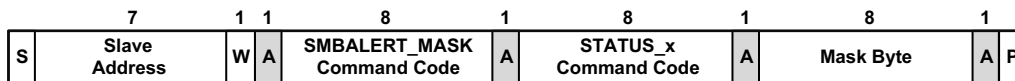

Figure 31. SMBALERT_MASK Command Packet Format

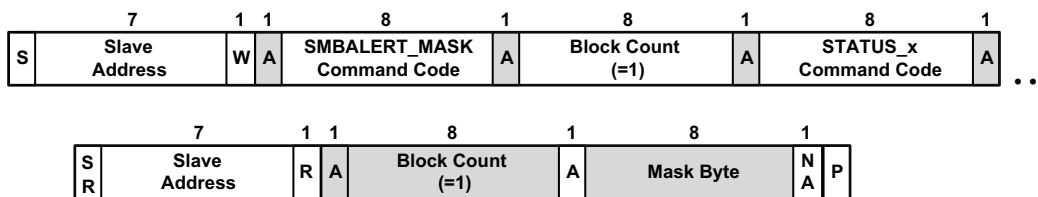

Figure 32. Retrieving the SMBALERT_MASK Setting for a Given Status Register

10.11 VOUT_MODE (20h)

Definition: Returns the supported V_{OUT} mode. Direct mode, 1mV per LSB.

Access: Global

Data Length in Bytes: 1

Data Format: Bit Field

Type: Read Only

Default Value: 40h

Command	VOUT_MODE (20h)							
Format	Bit Field							
Bit Position	7	6	5	4	3	2	1	0
Access	R/W	R/W	R/W	R/W	R/W	R/W	R/W	R/W
Function	Mode				Exponent			
Default Value	0	1	0	0	0	0	0	0

10.12 VOUT_COMMAND (21h)

Definition: Sets the value of V_{OUT} when the OPERATION command is configured for PMBus nominal operation. 1mV per LSB.

Access: Paged

Data Length in Bytes: 2

Data Format: Direct

Type: R/W

Default Value: 0384h (900mV)

Units: mV

Equation: V_{OUT} Command = (Direct value)

Range: 0mV to 3050mV

Command	VOUT_COMMAND (21h)																
Format	Direct																
Bit Position	15	14	13	12	11	10	9	8	7	6	5	4	3	2	1	0	
Access	R/W	R/W	R/W	R/W	R/W	R/W	R/W	R/W	R/W	R/W	R/W	R/W	R/W	R/W	R/W	R/W	
Function	Unsigned Integer																
Default Value	0	0	0	0	0	0	0	1	1	1	0	0	0	0	1	0	0

10.13 VOUT_TRIM (22h)

Definition: Applies a fixed trim voltage to the output voltage command value. This command is typically used to calibrate a device in the application circuit. 1mV per LSB.

Access: Paged

Data Length in Bytes: 2

Data Format: Direct

Type: R/W

Default Value: 0000h

Units: mV

Equation: V_{OUT} Trim = (Direct value)

Range: Any value that results in the V_{OUT} target being between 0V and V_{OUT_MAX}

Command	VOUT_TRIM (22h)																
Format	Direct																
Bit Position	15	14	13	12	11	10	9	8	7	6	5	4	3	2	1	0	
Access	R/W	R/W	R/W	R/W	R/W	R/W	R/W	R/W	R/W	R/W	R/W	R/W	R/W	R/W	R/W	R/W	
Function	Two's Complement Integer																
Default Value	0	0	0	0	0	0	0	0	0	0	0	0	0	0	0	0	0

10.14 VOUT_CAL_OFFSET (23h)

Definition: Applies a fixed offset voltage to the output voltage command value. This command is typically used to calibrate a device in the application circuit. 1mV per LSB.

Access: Paged

Data Length in Bytes: 2

Data Format: Direct

Type: R/W

Default Value: 0000h

Units: mV

Equation: V_{OUT} Cal Offset = (Direct value)

Range: Any value that results in the V_{OUT} target being between 0V and V_{OUT_MAX}

Command	VOUT_CAL_OFFSET (23h)															
Format	Direct															
Bit Position	15	14	13	12	11	10	9	8	7	6	5	4	3	2	1	0
Access	R/W	R/W	R/W	R/W	R/W	R/W	R/W	R/W	R/W	R/W	R/W	R/W	R/W	R/W	R/W	R/W
Function	Two's Complement Integer															
Default Value	0	0	0	0	0	0	0	0	0	0	0	0	0	0	0	0

10.15 VOUT_MAX (24h)

Definition: Sets the absolute maximum V_{OUT} regulation value regardless of any other commands or combinations. 1mV per LSB.

Access: Paged

Data Length in Bytes: 2

Data Format: Direct

Type: R/W

Default Value: 0BEAh (3050mV)

Units: mV

Equation: V_{OUT} Max = (Direct value)

Range: 0mV to 3050mV

Command	VOUT_MAX (24h)															
Format	Direct															
Bit Position	15	14	13	12	11	10	9	8	7	6	5	4	3	2	1	0
Access	R/W	R/W	R/W	R/W	R/W	R/W	R/W	R/W	R/W	R/W	R/W	R/W	R/W	R/W	R/W	R/W
Function	Unsigned Integer															
Default Value	0	0	0	0	1	0	1	1	1	1	1	0	1	0	1	0

10.16 VOUT_MARGIN_HIGH (25h)

Definition: Sets the value of V_{OUT} when the OPERATION command is configured for margin high. 1mV per LSB.

Access: Paged

Data Length in Bytes: 2

Data Format: Direct

Type: R/W

Default Value: 3B1h (945mV)

Units: mV

Equation: V_{OUT} Margin High = (Direct value)

Range: 0mV to 3050mV

Command	VOUT_MARGIN_HIGH (25h)																
Format	Direct																
Bit Position	15	14	13	12	11	10	9	8	7	6	5	4	3	2	1	0	
Access	R/W	R/W	R/W	R/W	R/W	R/W	R/W	R/W	R/W	R/W	R/W	R/W	R/W	R/W	R/W	R/W	
Function	Unsigned Integer																
Default Value	0	0	0	0	0	0	0	1	1	1	0	1	1	0	0	0	1

10.17 VOUT_MARGIN_LOW (26h)

Definition: Sets the value of V_{OUT} when the OPERATION command is configured for margin low. 1mV per LSB.

Access: Paged

Data Length in Bytes: 2

Data Format: Direct

Type: R/W

Default Value: 357h (855mV)

Units: mV

Equation: V_{OUT} Margin Low = (Direct value)

Range: 0mV to 3050mV

Command	VOUT_MARGIN_LOW (26h)																
Format	Direct																
Bit Position	15	14	13	12	11	10	9	8	7	6	5	4	3	2	1	0	
Access	R/W	R/W	R/W	R/W	R/W	R/W	R/W	R/W	R/W	R/W	R/W	R/W	R/W	R/W	R/W	R/W	
Function	Unsigned Integer																
Default Value	0	0	0	0	0	0	0	1	1	0	1	0	1	0	1	1	1

10.18 VOUT_TRANSITION_RATE (27h)

Definition: Defines the output voltage rate of change during regulation. 0.01mV/μs per LSB.

Access: Paged

Data Length in Bytes: 2

Data Format: Direct

Type: R/W

Default Value: 9C4h (25mV/μs)

Units: mV/μs

Equation: V_{OUT} Transition Rate = (Direct value) / 100

Range: 10μV/μs to 100mV/μs

Command	VOUT_TRANSITION_RATE (27h)															
Format	Direct															
Bit Position	15	14	13	12	11	10	9	8	7	6	5	4	3	2	1	0
Access	R/W	R/W	R/W	R/W	R/W	R/W	R/W	R/W	R/W	R/W	R/W	R/W	R/W	R/W	R/W	R/W
Function	Unsigned Integer															
Default Value	0	0	0	0	1	0	0	1	1	1	0	0	0	1	0	0

10.19 VOUT_DROOP (28h)

Definition: Sets the rate at which the output voltage changes relative to output current during regulation. 10μV/A per LSB.

Access: Paged

Data Length in Bytes: 2

Data Format: Direct

Type: R/W

Default Value: 0000h (0μV/A)

Units: μV/A

Equation: V_{OUT} Droop = (Direct value) x 10

Range: 0μV/A to 16000μV/A

Command	VOUT_DROOP (28h)															
Format	Direct															
Bit Position	15	14	13	12	11	10	9	8	7	6	5	4	3	2	1	0
Access	R/W	R/W	R/W	R/W	R/W	R/W	R/W	R/W	R/W	R/W	R/W	R/W	R/W	R/W	R/W	R/W
Function	Unsigned Integer															
Default Value	0	0	0	0	0	0	0	0	0	0	0	0	0	0	0	0

10.20 VOUT_MIN (2Bh)

Definition: Sets the absolute minimum voltage that is delivered to the output during regulation. 1mV per LSB.

Access: Paged

Data Length in Bytes: 2

Data Format: Direct

Type: R/W

Default Value: 0000h

Units: mV

Equation: $V_{OUT\ Min} = (\text{Direct value})$

Range: 0mV to 3050mV

Command	VOUT_MIN (2Bh)															
Format	Direct															
Bit Position	15	14	13	12	11	10	9	8	7	6	5	4	3	2	1	0
Access	R/W	R/W	R/W	R/W	R/W	R/W	R/W	R/W	R/W	R/W	R/W	R/W	R/W	R/W	R/W	R/W
Function	Unsigned Integer															
Default Value	0	0	0	0	0	0	0	0	0	0	0	0	0	0	0	0

10.21 FREQUENCY_SWITCH (33h)

Definition: Sets the PWM switching frequency during regulation. 1kHz per LSB.

Access: Paged

Data Length in Bytes: 2

Data Format: Direct

Type: R/W

Default Value: 0258h (600kHz)

Units: kHz

Equation: Frequency Switch = (Direct value)

Range: 200kHz to 2MHz

Command	FREQUENCY_SWITCH (33h)															
Format	Direct															
Bit Position	15	14	13	12	11	10	9	8	7	6	5	4	3	2	1	0
Access	R/W	R/W	R/W	R/W	R/W	R/W	R/W	R/W	R/W	R/W	R/W	R/W	R/W	R/W	R/W	R/W
Function	Unsigned Integer															
Default Value	0	0	0	0	0	0	1	0	0	1	0	1	1	0	0	0

10.22 POWER_MODE (34h)

Definition: Sets the power conversion mode.

Maximum Efficiency Mode (0) default settings:

- Voltage down transitions happen immediately with decay (PWM tri-state).
- Phase dropping is enabled irrespective of the APD setting in the LOOPCFG command.
- Diode emulation can be enabled using LOOPCFG[6].

Maximum Power Mode (3) default settings:

- Voltage down transitions happen as programmed in the TOFF_DELAY and TOFF_FALL commands.
- Phase automatic add/drop is enabled using LOOPCFG[0].
- Diode emulation can be enabled using LOOPCFG[28].

MFR Defined Mode (4) default settings:

- Voltage down transitions happen immediately with decay (PWM tri-state).
- Phase dropping is enabled irrespective of the APD setting in the LOOPCFG command.
- Diode emulation can be enabled using LOOPCFG[6] and LOOPCFG[28].

Access: Paged

Data Length in Bytes: 1

Data Format: Bit Field

Type: R/W

Default Value: 03h, Maximum Power

Command	POWER_MODE (34h)							
Format	Bit Field							
Bit Position	7	6	5	4	3	2	1	0
Access	R/W	R/W	R/W	R/W	R/W	R/W	R/W	R/W
Function	See Following Table							
Default Value	0	0	0	0	0	0	1	1

Bit Value	Setting
04h	MFR defined
03h	Maximum Power
00h	Maximum Efficiency

10.23 VIN_ON (35h)

Definition: Sets the input voltage rising threshold at which the output can be enabled. 10mV per LSB.

Access: Paged

Data Length in Bytes: 2

Data Format: Direct

Type: R/W

Default Value: 02BCh (7000mV)

Units: mV

Equation: $V_{IN\ On} = (\text{Direct value}) \times 10$

Range: -327680mV to 327670mV

Command	VIN_ON (35h)															
Format	Direct															
Bit Position	15	14	13	12	11	10	9	8	7	6	5	4	3	2	1	0
Access	R/W	R/W	R/W	R/W	R/W	R/W	R/W	R/W	R/W	R/W	R/W	R/W	R/W	R/W	R/W	R/W
Function	Two's Complement Integer															
Default Value	0	0	0	0	0	0	1	0	1	0	1	1	1	1	0	0

10.24 VIN_OFF (36h)

Definition: Sets the input voltage falling threshold at which the output disables. 10mV per LSB.

Access: Paged

Data Length in Bytes: 2

Data Format: Direct

Type: R/W

Default Value: 01F4 (5000mV)

Units: mV

Equation: $V_{IN\ Off} = (\text{Direct value}) \times 10$

Range: -327680mV to 327670mV

Command	VIN_OFF (36h)															
Format	Direct															
Bit Position	15	14	13	12	11	10	9	8	7	6	5	4	3	2	1	0
Access	R/W	R/W	R/W	R/W	R/W	R/W	R/W	R/W	R/W	R/W	R/W	R/W	R/W	R/W	R/W	R/W
Function	Two's Complement Integer															
Default Value	0	0	0	0	0	0	0	1	1	1	1	1	0	1	0	0

10.25 VOUT_OV_FAULT_LIMIT (40h)

Definition: Sets the output overvoltage threshold. 1mV per LSB.

Access: Paged

Data Length in Bytes: 2

Data Format: Direct

Type: R/W

Default Value: 0C1Ch (3100mV)

Units: mV

Equation: $V_{OUT\ OV\ Fault\ Limit} = (\text{Direct value})$

Range: 0mV to 3050mV

Command	VOUT_OV_FAULT_LIMIT (40h)															
Format	Direct															
Bit Position	15	14	13	12	11	10	9	8	7	6	5	4	3	2	1	0
Access	R/W	R/W	R/W	R/W	R/W	R/W	R/W	R/W	R/W	R/W	R/W	R/W	R/W	R/W	R/W	R/W
Function	Unsigned Integer															
Default Value	0	0	0	0	1	1	0	0	0	0	0	1	1	1	0	0

10.26 VOUT_OV_FAULT_RESPONSE (41h)

Definition: Configures the output overvoltage fault response. For a fault to be considered cleared, the output must drop by 100mV.

Access: Paged

Data Length in Bytes: 1

Data Format: Bit Field

Type: R/W

Default Value: 84h (latch off)

Command	VOUT_OV_FAULT_RESPONSE (41h)							
Format	Bit Field							
Bit Position	7	6	5	4	3	2	1	0
Access	R/W	R/W	R/W	R/W	R/W	R/W	R/W	R/W
Function	See Following Table							
Default Value	1	0	0	0	0	1	0	0

Bit	Field Name	Value	Description
7:6	ResponseBehavior During a fault, the device: • Pulls PMALRT low • Sets the related fault bit in the status registers.	00	Continue without interruption.
		01	Not supported
		10	Disable and retry according to the setting in Bits [5:3].
		11	Not supported
5:3	Retry Setting	000	No retry. The output remains disabled until the rail is restarted.
		001-110	Not supported
		111	Attempts to restart continuously, without limitation, until it is commanded OFF (by the CONTROL pin or OPERATION command), bias power is removed, or another fault condition causes the unit to shut down. The time between retries is set by Bits [2:0].
2:0	Delay Time before Retry	000	0ms delay (not recommended)
		001-110	Delay 25ms per LSB
		111	Delay 175ms

10.27 VOUT_UV_FAULT_LIMIT (44h)

Definition: Sets the output undervoltage fault threshold. 1mV per LSB. This fault is masked during ramp or when disabled.

Access: Paged

Data Length in Bytes: 2

Data Format: Direct

Type: R/W

Default Value: 0V

Units: mV

Equation: V_{OUT} UV Fault Limit = (Direct value)

Range: 0V to 3.05V

Command	VOUT_UV_FAULT_LIMIT (44h)															
Format	Direct															
Bit Position	15	14	13	12	11	10	9	8	7	6	5	4	3	2	1	0
Access	R/W	R/W	R/W	R/W	R/W	R/W	R/W	R/W	R/W	R/W	R/W	R/W	R/W	R/W	R/W	R/W
Function	Unsigned Integer															
Default Value	0	0	0	0	0	0	0	0	0	0	0	0	0	0	0	0

10.28 VOUT_UV_FAULT_RESPONSE (45h)

Definition: Configures the output undervoltage fault response. This fault is masked during ramp or when disabled.

Access: Paged

Data Length in Bytes: 1

Data Format: Bit Field

Type: R/W

Default Value: 84h (latch off)

Command	VOUT_UV_FAULT_RESPONSE (45h)							
Format	Bit Field							
Bit Position	7	6	5	4	3	2	1	0
Access	R/W	R/W	R/W	R/W	R/W	R/W	R/W	R/W
Function	See Following Table							
Default Value	1	0	0	0	0	1	0	0

Bit	Field Name	Value	Description
7:6	ResponseBehavior During a fault, the device: • Pulls PMALRT low • Sets the related fault bit in the status registers.	00	Continue without interruption.
		01	Not supported
		10	Disable and retry according to the setting in Bits [5:3].
		11	Not supported
5:3	Retry Setting	000	No retry. The output remains disabled until the rail is restarted.
		001-110	Not supported
		111	Attempts to restart continuously, without limitation, until it is commanded OFF (by the CONTROL pin or OPERATION command), bias power is removed, or another fault condition causes the unit to shut down. The time between retries is set by Bits [2:0].
2:0	Delay Time before Retry	000	Delay 0ms (not recommended)
		001-110	Delay 25ms per LSB
		111	Delay 175ms

10.29 IOUT_OC_FAULT_LIMIT (46h)

Definition: Sets the fast sum output overcurrent fault threshold. 0.1A per LSB.

Access: Paged

Data Length in Bytes: 2

Data Format: Direct

Type: R/W

Default Value: 12Ch (30A)

Units: A

Equation: $I_{OUT\ OC\ Fault\ Limit} = (\text{Direct value}) / 10$

Range: 0A to 3276.7A

Command	IOUT_OC_FAULT_LIMIT (46h)																
Format	Direct																
Bit Position	15	14	13	12	11	10	9	8	7	6	5	4	3	2	1	0	
Access	R/W	R/W	R/W	R/W	R/W	R/W	R/W	R/W	R/W	R/W	R/W	R/W	R/W	R/W	R/W	R/W	
Function	Unsigned Integer																
Default Value	0	0	0	0	0	0	0	0	1	0	0	1	0	1	1	0	0

10.30 IOUT_OC_FAULT_RESPONSE (47h)

Definition: Configures the output overcurrent fault response for all I_{OUT} OC detection methods. This response setting is also applied to output undercurrent faults.

Access: Paged

Data Length in Bytes: 1

Data Format: Bit Field

Type: R/W

Default Value: C4h (latch off)

Command	IOUT_OC_FAULT_RESPONSE (47h)							
Format	Bit Field							
Bit Position	7	6	5	4	3	2	1	0
Access	R/W	R/W	R/W	R/W	R/W	R/W	R/W	R/W
Function	See Following Table							
Default Value	1	1	0	0	0	1	0	0

Bit	Field Name	Value	Description
7:6	ResponseBehavior During a fault, the device: <ul style="list-style-type: none"> • Pulls PMALRT low • Sets the related fault bit in the status registers. 	00	Continue without interruption.
		01-10	Not supported
		11	Disable and retry as set in Bits [5:3]
5:3	Retry Setting	000	No retry. The output remains disabled until the rail is restarted.
		001-110	Not supported
		111	Attempts to restart continuously, without limitation, until it is commanded OFF (by the CONTROL pin or OPERATION command), bias power is removed, or another fault condition causes the unit to shut down. The time between retries is set by Bits [2:0].
2:0	Delay Time before Retry	000	Delay 0ms (not recommended)
		001-110	Delay 25ms per LSB
		111	Delay 175ms

10.31 OT_FAULT_LIMIT (4Fh)

Definition: Sets the power stage over-temperature fault limit. 1°C per LSB.

Access: Paged

Data Length in Bytes: 2

Data Format: Direct

Type: R/W

Default Value: 007Dh (125°C)

Units: °C

Equation: OT Fault Limit = (Direct value)

Range: 0°C to +150°C

Command	OT_FAULT_LIMIT (4Fh)																
Format	Direct																
Bit Position	15	14	13	12	11	10	9	8	7	6	5	4	3	2	1	0	
Access	R/W	R/W	R/W	R/W	R/W	R/W	R/W	R/W	R/W	R/W	R/W	R/W	R/W	R/W	R/W	R/W	
Function	Unsigned Integer																
Default Value	0	0	0	0	0	0	0	0	0	0	1	1	1	1	1	0	1

10.32 OT_FAULT_RESPONSE (50h)

Definition: Configures the power stage over-temperature fault response. For a fault to be considered cleared, the temperature must drop 5°C below the OT fault threshold value.

Access: Paged

Data Length in Bytes: 1

Data Format: Bit Field

Type: R/W

Default Value: 84h (latch off)

Command	OT_FAULT_RESPONSE (50h)							
Format	Bit Field							
Bit Position	7	6	5	4	3	2	1	0
Access	R/W	R/W	R/W	R/W	R/W	R/W	R/W	R/W
Function	See Following Table							
Default Value	1	0	0	0	0	1	0	0

Bit	Field Name	Value	Description
7:6	ResponseBehavior During a fault, the device: • Pulls PMALRT low • Sets the related fault bit in the status registers.	00	Continue without interruption.
		01	Not supported
		10	Disable and retry according to the setting in Bits [5:3].
		11	Not supported
5:3	Retry Setting	000	No retry. The output remains disabled until the rail is restarted.
		001-110	Not supported
		111	Attempts to restart continuously, without limitation, until it is commanded OFF (by the CONTROL pin or OPERATION command), bias power is removed, or another fault condition causes the unit to shut down. The time between retries is set by Bits [2:0].
2:0	Delay Time before Retry	000	Delay 0ms (not recommended)
		001-110	Delay 25ms per LSB
		111	Delay 175ms

10.33 OT_WARN_LIMIT (51h)

Definition: Sets the power stage over-temperature warning limit. 1°C per LSB.

Access: Paged

Data Length in Bytes: 2

Data Format: Direct

Type: R/W

Default Value: 006Eh (110°C)

Units: °C

Equation: OT Warn Limit = (Direct value)

Range: 0°C to 150°C

Command	OT_WARN_LIMIT (51h)																
Format	Direct																
Bit Position	15	14	13	12	11	10	9	8	7	6	5	4	3	2	1	0	
Access	R/W	R/W	R/W	R/W	R/W	R/W	R/W	R/W	R/W	R/W	R/W	R/W	R/W	R/W	R/W	R/W	
Function	Two's Complement Integer																
Default Value	0	0	0	0	0	0	0	0	0	0	1	1	0	1	1	1	0

10.34 UT_FAULT_LIMIT (53h)

Definition: Sets the power stage under-temperature fault limit. 1°C per LSB.

Access: Paged

Data Length in Bytes: 2

Data Format: Direct

Type: R/W

Default Value: FFD8h (-40°C)

Units: °C

Equation: UT Fault Limit = (Direct value)

Range: -50°C to 150°C

Command	UT_FAULT_LIMIT (53h)																
Format	Direct																
Bit Position	15	14	13	12	11	10	9	8	7	6	5	4	3	2	1	0	
Access	R/W	R/W	R/W	R/W	R/W	R/W	R/W	R/W	R/W	R/W	R/W	R/W	R/W	R/W	R/W	R/W	
Function	Two's Complement Integer																
Default Value	1	1	1	1	1	1	1	1	1	1	1	0	1	1	0	0	0

10.35 UT_FAULT_RESPONSE (54h)

Definition: Configures the power stage under-temperature fault response. For the fault to be considered cleared, the temperature must rise 5°C above the UT fault threshold value.

Access: Paged

Data Length in Bytes: 1

Data Format: Bit Field

Type: R/W

Default Value: 84h (latch off)

Command	UT_FAULT_RESPONSE (54h)							
Format	Bit Field							
Bit Position	7	6	5	4	3	2	1	0
Access	R/W	R/W	R/W	R/W	R/W	R/W	R/W	R/W
Function	See Following Table							
Default Value	1	0	0	0	0	1	0	0

Bit	Field Name	Value	Description
7:6	ResponseBehavior During a fault, the device: • Pulls PMALRT low • Sets the related fault bit in the status registers.	00	Continue without interruption.
		01	Not supported
		10	Disable and retry according to the setting in Bits [5:3].
		11	Not supported
5:3	Retry Setting	000	No retry. The output remains disabled until the device is restarted.
		001-110	Not supported
		111	Attempts to restart continuously without limitation until it is commanded OFF (by the CONTROL pin or OPERATION command), bias power is removed, or another fault condition causes the unit to shut down. The time between retries is set by Bits [2:0].
2:0	Delay Time before Retry	000	Delay 0ms (not recommended)
		001-110	Delay 25ms per LSB
		111	Delay 175ms

10.36 VIN_OV_FAULT_LIMIT (55h)

Definition: Sets the V_{IN} overvoltage fault threshold. 10mV per LSB.

Access: Paged

Data Length in Bytes: 2

Data Format: Direct

Type: R/W

Default Value: 640h (16000mV)

Units: mV

Equation: V_{IN} OV Fault Limit = (Direct value) x 10

Range: 0mV to 327670mV

Command	VIN_OV_FAULT_LIMIT (55h)															
Format	Direct															
Bit Position	15	14	13	12	11	10	9	8	7	6	5	4	3	2	1	0
Access	R/W	R/W	R/W	R/W	R/W	R/W	R/W	R/W	R/W	R/W	R/W	R/W	R/W	R/W	R/W	R/W
Function	Two's Complement Integer															
Default Value	0	0	0	0	0	1	1	0	0	1	0	0	0	0	0	0

10.37 VIN_OV_FAULT_RESPONSE (56h)

Definition: Configures the input overvoltage fault response. For a fault to be considered cleared, the input voltage must drop by 1/16th of the OV fault threshold value.

Access: Paged

Data Length in Bytes: 1

Data Format: Bit Field

Type: R/W

Default Value: 84h (latch off)

Command	VIN_OV_FAULT_RESPONSE (56h)							
Format	Bit Field							
Bit Position	7	6	5	4	3	2	1	0
Access	R/W	R/W	R/W	R/W	R/W	R/W	R/W	R/W
Function	See Following Table							
Default Value	1	0	0	0	0	1	0	0

Bit	Field Name	Value	Description
7:6	Response Behavior During a fault, the device: <ul style="list-style-type: none"> • Pulls PMALRT low • Sets the related fault bit in the status registers. 	00	Continue without interruption.
		01	Not supported
		10	Disable and retry according to the setting in Bits [5:3].
		11	Not supported
5:3	Retry Setting	000	No retry. The output remains disabled until the device is restarted.
		001-110	Not supported
		111	Attempts to restart continuously without limitation until it is commanded OFF (by the CONTROL pin or OPERATION command), bias power is removed, or another fault condition causes the unit to shut down. The time between retries is set by Bits [2:0].
2:0	Delay Time before Retry	000	Delay 0ms (not recommended)
		001-110	Delay 25ms per LSB
		111	Delay 175ms

10.38 VIN_OV_WARN_LIMIT (57h)**Definition:** Sets the V_{IN} overvoltage fault threshold. 10mV per LSB.**Access:** Paged**Data Length in Bytes:** 2**Data Format:** Direct**Type:** R/W**Default Value:** 708h (18000mV)**Units:** mV**Equation:** V_{IN} OV Warn Limit = (Direct value) x 10**Range:** 0mV to 327670mV

Command	VIN_OV_WARN_LIMIT (57h)															
Format	Direct															
Bit Position	15	14	13	12	11	10	9	8	7	6	5	4	3	2	1	0
Access	R/W	R/W	R/W	R/W	R/W	R/W	R/W	R/W	R/W	R/W	R/W	R/W	R/W	R/W	R/W	R/W
Function	Two's Complement Integer															
Default Value	0	0	0	0	0	1	1	1	0	0	0	0	1	0	0	0

10.39 VIN_UV_WARN_LIMIT (58h)**Definition:** Sets the V_{IN} undervoltage warning threshold. 10mV per LSB.**Access:** Paged**Data Length in Bytes:** 2**Data Format:** Direct**Type:** R/W**Default Value:** 0000h (0V)**Units:** mV**Equation:** V_{IN} UV Warn Limit = (Direct value) x 10**Range:** 0mV to 327670mV

Command	VIN_UV_WARN_LIMIT (58h)															
Format	Direct															
Bit Position	15	14	13	12	11	10	9	8	7	6	5	4	3	2	1	0
Access	R/W	R/W	R/W	R/W	R/W	R/W	R/W	R/W	R/W	R/W	R/W	R/W	R/W	R/W	R/W	R/W
Function	Two's Complement Integer															
Default Value	0	0	0	0	0	0	0	0	0	0	0	0	0	0	0	0

10.40 VIN_UV_FAULT_LIMIT (59h)

Definition: Sets the V_{IN} undervoltage fault threshold. 10mV per LSB. If using VIN_ON and VIN_OFF commands, this command should be set to 0V.

Access: Paged

Data Length in Bytes: 2

Data Format: Direct

Type: R/W

Default Value: 0000h (0V)

Units: mV

Equation: V_{IN} UV Fault Limit = (Direct value) x 10

Range: -327680mV to 327670mV

Command	VIN_UV_FAULT_LIMIT (59h)															
Format	Direct															
Bit Position	15	14	13	12	11	10	9	8	7	6	5	4	3	2	1	0
Access	R/W	R/W	R/W	R/W	R/W	R/W	R/W	R/W	R/W	R/W	R/W	R/W	R/W	R/W	R/W	R/W
Function	Two's Complement Integer															
Default Value	0	0	0	0	0	0	0	0	0	0	0	0	0	0	0	0

10.41 VIN_UV_FAULT_RESPONSE (5Ah)

Definition: Configures the input undervoltage fault response. For a fault to be considered cleared, the input voltage must rise by 1/16th of the UV fault threshold value.

Access: Paged

Data Length in Bytes: 1

Data Format: Bit Field

Type: R/W

Default Value: 84h (latch off)

Command	VIN_UV_FAULT_RESPONSE (5Ah)							
Format	Bit Field							
Bit Position	7	6	5	4	3	2	1	0
Access	R/W	R/W	R/W	R/W	R/W	R/W	R/W	R/W
Function	See Following Table							
Default Value	1	0	0	0	0	1	0	0

Bit	Field Name	Value	Description
7:6	Response Behavior During a fault, the device: <ul style="list-style-type: none"> • Pulls PMALRT low • Sets the related fault bit in the status registers. 	00	Continue without interruption.
		01	Not supported
		10	Disable and retry according to the setting in Bits [5:3].
		11	Not supported
5:3	Retry Setting	000	No retry. The output remains disabled until the device is restarted.
		001-110	Not supported
		111	Attempts to restart continuously, without limitation, until it is commanded OFF (by the CONTROL pin or OPERATION command), bias power is removed, or another fault condition causes the unit to shut down. The time between retries is set by Bits [2:0].
2:0	Delay Time before Retry	000	Delay 0ms (not recommended)
		001-110	Delay 25ms per LSB
		111	Delay 175ms

10.42 IIN_OC_FAULT_LIMIT (5Bh)

Definition: Sets the input overcurrent fault threshold for the synthesized input current reading at READ_IIN. 10mA per LSB.

Access: Paged

Data Length in Bytes: 2

Data Format: Direct

Type: R/W

Default Value: 1388h (50A)

Units: A

Equation: $I_{IN} \text{ OC Fault Limit} = (\text{Direct value}) / 100$

Range: -327.68A to 327.67A

Command	IIN_OC_FAULT_LIMIT (5Bh)															
Format	Direct															
Bit Position	15	14	13	12	11	10	9	8	7	6	5	4	3	2	1	0
Access	R/W	R/W	R/W	R/W	R/W	R/W	R/W	R/W	R/W	R/W	R/W	R/W	R/W	R/W	R/W	R/W
Function	Two's Complement Integer															
Default Value	0	0	0	1	0	0	1	1	1	0	0	0	1	0	0	0

10.43 IIN_OC_FAULT_RESPONSE (5Ch)

Definition: Configures the input overcurrent fault response for the synthesized input current reading at READ_IIN.

Access: Paged

Data Length in Bytes: 1

Data Format: Bit Field

Type: R/W

Default Value: 04h (ignore)

Command	IIN_OC_FAULT_RESPONSE (5Ch)							
Format	Bit Field							
Bit Position	7	6	5	4	3	2	1	0
Access	R/W	R/W	R/W	R/W	R/W	R/W	R/W	R/W
Function	See Following Table							
Default Value	0	0	0	0	0	1	0	0

Bit	Field Name	Value	Description
7:6	ResponseBehavior During a fault, the device: <ul style="list-style-type: none"> • Pulls PMALRT low • Sets the related fault bit in the status registers. 	00	Continue without interruption.
		01-10	Not supported
		11	Disable and retry as set in Bits [5:3]
5:3	Retry Setting	000	No retry. The output remains disabled until the device is restarted
		001-110	Not supported
		111	Attempts to restart continuously, without limitation, until it is commanded OFF (by the CONTROL pin or OPERATION command), bias power is removed, or another fault condition causes the unit to shut down. The time between retries is set by Bits [2:0].
2:0	Delay Time before Retry	000	Delay 0ms (not recommended)
		001-110	Delay 25ms per LSB
		111	Delay 175ms

10.44 IIN_OC_WARN_LIMIT (5Dh)

Definition: Sets the input overcurrent warning threshold. 10mA per LSB.

Access: Paged

Data Length in Bytes: 2

Data Format: Direct

Type: R/W

Default Value: 3A98h (150A)

Units: A

Equation: $I_{IN} \text{ OC Warn Limit} = (\text{Direct value}) / 100$

Range:

Command	IIN_OC_WARN_LIMIT (5Dh)															
Format	Direct															
Bit Position	15	14	13	12	11	10	9	8	7	6	5	4	3	2	1	0
Access	R/W	R/W	R/W	R/W	R/W	R/W	R/W	R/W	R/W	R/W	R/W	R/W	R/W	R/W	R/W	R/W
Function	Two's Complement Integer															
Default Value	0	0	1	1	1	0	1	0	1	0	0	1	1	0	0	0

10.45 TON_DELAY (60h)

Definition: Sets the delay time from when the device is enabled to the start of V_{OUT} rise. 10 μ s per LSB.

Access: Paged

Data Length in Bytes: 2

Data Format: Direct

Type: R/W

Default Value: 0000h (0 μ s)

Units: μ s

Equation: $t_{ON} \text{ Delay} = (\text{Direct value}) \times 10$

Range: 0 μ s to 655534 μ s

Command	TON_DELAY (60h)															
Format	Direct															
Bit Position	15	14	13	12	11	10	9	8	7	6	5	4	3	2	1	0
Access	R/W	R/W	R/W	R/W	R/W	R/W	R/W	R/W	R/W	R/W	R/W	R/W	R/W	R/W	R/W	R/W
Function	Unsigned Integer															
Default Value	0	0	0	0	0	0	0	0	0	0	0	0	0	0	0	0

10.46 TON_RISE (61h)

Definition: Sets the rise time of V_{OUT} during enable. 1 μ s per LSB.

Access: Paged

Data Length in Bytes: 2

Data Format: Direct

Type: R/W

Default Value: 14Fh (500 μ s)

Units: μ s

Equation: t_{ON} Rise = (Direct value)

Range: 0 μ s to 10000 μ s

Command	TON_RISE (61h)															
Format	Direct															
Bit Position	15	14	13	12	11	10	9	8	7	6	5	4	3	2	1	0
Access	R/W	R/W	R/W	R/W	R/W	R/W	R/W	R/W	R/W	R/W	R/W	R/W	R/W	R/W	R/W	R/W
Function	Unsigned Integer															
Default Value	0	0	0	0	0	0	0	1	0	1	0	0	1	1	1	1

10.47 TOFF_DELAY (64h)

Definition: Sets the delay time of V_{OUT} during disable when configured for soft off. 10 μ s per LSB.

Access: Paged

Data Length in Bytes: 2

Data Format: Direct

Type: R/W

Default Value: 0000h (0 μ s)

Units: μ s

Equation: t_{OFF} Delay = (Direct value) x 10

Range: 0 μ s to 655534 μ s

Command	TOFF_DELAY (64h)															
Format	Direct															
Bit Position	15	14	13	12	11	10	9	8	7	6	5	4	3	2	1	0
Access	R/W	R/W	R/W	R/W	R/W	R/W	R/W	R/W	R/W	R/W	R/W	R/W	R/W	R/W	R/W	R/W
Function	Unsigned Integer															
Default Value	0	0	0	0	0	0	0	0	0	0	0	0	0	0	0	0

10.48 TOFF_FALL (65h)

Definition: Sets the fall time of V_{OUT} during disable when configured for soft off. 1 μ s per LSB.

Access: Paged

Data Length in Bytes: 2

Data Format: Direct

Type: R/W

Default Value: 14Fh (500 μ s)

Units: μ s

Equation: t_{OFF} Fall = (Direct value)

Range: 0 μ s to 10000 μ s

Command	TOFF_FALL (65h)																
Format	Direct																
Bit Position	15	14	13	12	11	10	9	8	7	6	5	4	3	2	1	0	
Access	R/W	R/W	R/W	R/W	R/W	R/W	R/W	R/W	R/W	R/W	R/W	R/W	R/W	R/W	R/W	R/W	
Function	Unsigned Integer																
Default Value	0	0	0	0	0	0	0	0	1	0	1	0	0	1	1	1	1

10.49 STATUS_BYTE (78h)

Definition: Returns a summary of the device status. Based on the information in this byte, the host can get more information by reading the appropriate status registers. Depending on the setting of the PAGE command, this command returns information about individual rails or a global summary of all rail statuses.

Access: Paged and Global

Data Length in Bytes: 2

Data Format: Bit Field

Type: Read Only

Command	STATUS_BYTE (78h)							
Format	Bit Field							
Bit Position	7	6	5	4	3	2	1	0
Access	R	R	R	R	R	R	R	R
Function	See Following Table							

Bit Number	Status Bit Name	Meaning
7	BUSY	A fault was declared because the device was busy and unable to respond.
6	OFF	This bit is asserted if the unit is not providing power to the output, regardless of the reason, including simply not being enabled.
5	VOUT_OV_FAULT	An output overvoltage fault occurred.
4	IOUT_OC_FAULT	An output overcurrent fault occurred.
3	VIN_UV_FAULT	An input undervoltage fault occurred.
2	TEMPERATURE	A temperature fault or warning occurred.
1	CML	A communications, memory, or logic fault occurred.
0	None of the Above	A fault other than those listed above occurred.

10.50 STATUS_WORD (79h)

Definition: Returns a summary of the device's status. Based on the information in these bytes, the host can get more information by reading the appropriate status registers. Depending on the setting of the PAGE command, this command returns information about individual rails or a global summary of all rail statuses. The low byte of the STATUS_WORD is the same as the STATUS_BYTE (78h) command.

Access: Paged and Global

Data Length in Bytes: 2

Data Format: Bit Field

Type: Read Only

Command	STATUS_WORD (79h)															
Format	Bit Field															
Bit Position	15	14	13	12	11	10	9	8	7	6	5	4	3	2	1	0
Access	R	R	R	R	R	R	R	R	R	R	R	R	R	R	R	R
Function	See Following Table															

Bit Number	Status Bit Name	Meaning
15	V _{OUT}	An output voltage fault or warning occurred.
14	IOUT	An output current fault occurred.
13	INPUT	An input voltage fault or warning occurred.
12	MFR_SPECIFIC	A manufacturer specific fault or warning occurred.
11	POWER_GOOD #	The POWER_GOOD signal is negated (Note 8).
10:9	Not Supported	Not supported
8	Unknown	A fault other than those described in Bits 15:9 occurred.
7	Busy	Device busy and unable to respond.
6	OFF	This bit is asserted if the unit is not providing power to the output, regardless of the reason, including simply not being enabled.
5	VOUT_OV_FAULT	An output overvoltage fault occurred.
4	IOUT_OC_FAULT	An output overcurrent fault occurred.
3	VIN_UV_FAULT	An input undervoltage fault occurred.
2	TEMPERATURE	A temperature fault or warning occurred.
1	CML	A communications, memory, or logic fault occurred.
0	None of the Above	A status change other than those listed above occurred.

Note:

8. If the POWER_GOOD# Bit is set, this indicates that the POWER_GOOD signal is signaling that the output power is not good.

10.51 STATUS_VOUT (7Ah)

Definition: Returns a summary of output voltage status.

Access: Paged

Data Length in Bytes: 1

Data Format: Bit Field

Type: Read Only

Command	STATUS_VOUT (7Ah)							
Format	Bit Field							
Bit Position	7	6	5	4	3	2	1	0
Access	R	R	R	R	R	R	R	R
Function	See Following Table							

Bit Number	Status Bit Name	Meaning
7	VOUT_OV_FAULT	Indicates an output overvoltage fault occurred.
6:5	Not Supported	Not supported
4	VOUT_UV_FAULT	Indicates an output undervoltage fault occurred.
3	VOUT_MAX Warning	Indicates an output voltage maximum warning occurred.
2:0	Not Supported	Not supported

10.52 STATUS_IOUT (7Bh)

Definition: Returns a summary of output current status.

Access: Paged

Data Length in Bytes: 1

Data Format: Bit Field

Type: Read Only

Command	STATUS_IOUT (7Bh)							
Format	Bit Field							
Bit Position	7	6	5	4	3	2	1	0
Access	R	R	R	R	R	R	R	R
Function	See Following Table							

Bit Number	Status Bit Name	Meaning
7	IOUT_OC_FAULT	An output overcurrent fault occurred.
6	Not Supported	Not supported
5	Not supported	Not supported
4	IOUT_UC_FAULT	An output undercurrent fault occurred.
3	Current Share Fault	A current share fault occurred.
2:0	Not Supported	Not supported

10.53 STATUS_INPUT (7Ch)

Definition: Returns a summary of input status.

Access: Paged

Data Length in Bytes: 1

Data Format: Bit Field

Type: Read Only

Command	STATUS_INPUT (7Ch)							
Format	Bit Field							
Bit Position	7	6	5	4	3	2	1	0
Access	R	R	R	R	R	R	R	R
Function	See Following Table							

Bit Number	Status Bit Name	Meaning
7	VIN_OV_FAULT	An input overvoltage fault occurred.
6	VIN_OV_WARN	An input overvoltage warning occurred.
5	VIN_UV_WARN	An input undervoltage warning occurred.
4	VIN_UV_FAULT	An input undervoltage fault occurred.
3	VIN_ON/OFF	Disabled due to insufficient input voltage. This could be VIN or VMON.
2	IIN_OC_FAULT	An input overcurrent fault occurred.
1	IIN_OC_WARN	An input overcurrent warning occurred.
0	Not Supported	Not supported

10.54 STATUS_TEMPERATURE (7Dh)

Definition: Returns a summary of temperature status.

Access: Paged

Data Length in Bytes: 1

Data Format: Bit Field

Type: Read Only

Command	STATUS_TEMPERATURE (7Dh)							
Format	Bit Field							
Bit Position	7	6	5	4	3	2	1	0
Access	R	R	R	R	R	R	R	R
Function	See Following Table							

Bit Number	Status Bit Name	Meaning
7	OT_FAULT	An over-temperature fault occurred.
6	OT_WARN	An over-temperature warning occurred.
5	Not Supported	Not supported
4	UT_FAULT	An under-temperature fault occurred.
3:0	Not Supported	Not supported

10.55 STATUS_CML (7Eh)

Definition: Returns a summary of any communications, logic, and/or memory errors.

Access: Global

Data Length in Bytes: 1

Data Format: Bit Field

Type: Read Only

Command	STATUS_CML (7Eh)							
Format	Bit Field							
Bit Position	7	6	5	4	3	2	1	0
Access	R	R	R	R	R	R	R	R
Function	See Following Table							

Bit Number	Status Bit Name	Meaning
7	IUCR	Invalid or unsupported PMBus command was received. This bit sets during device discovery when using PowerNavigator.
6	IUDR	The PMBus command was sent with invalid or unsupported data.
5	PECF	A packet error check failure was detected in the PMBus command.
4	MFD	Memory fault detected. This bit sets if the selected NVM configuration location is empty or invalid.
3	PFD	Processor fault detected
2	Not Supported	Not supported
1	OCF	A communication fault other than the ones listed in this table occurred.
0	OMLF	A memory or logical fault not listed previously was detected.

10.56 STATUS_MFR_SPECIFIC (80h)

Definition: Returns a summary of the manufacturer specific status.

Access: Global

Data Length in Bytes: 1

Data Format: Bit Field

Type: Read Only

Command	STATUS_MFR_SPECIFIC (80h)							
Format	Bit Field							
Bit Position	7	6	5	4	3	2	1	0
Access	R	R	R	R	R	R	R	R
Function	See Following Table							

Bit	Status Bit Name	Meaning
7	ADCUNLOCK	ADC clock unlock detected.
6	Not Supported	Not supported
5	CFP Fault	A CFP fault occurred.
4	Internal Temperature Fault	The controller internal temperature exceeded 130 °C.
3	BBEVENT	A Black Box event occurred.
2	LMSEvent	A Last Man Standing event occurred.
1	SPSFault	An SPS overcurrent and/or over-temperature event occurred.
0	Not Supported	Not supported

10.57 READ_VIN (88h)

Definition: Returns the input voltage reading, scaled at 10mV per LSB.

Access: Paged

Data Length in Bytes: 2

Data Format: Direct

Type: Read Only

Units: mV

Equation: Read $V_{IN} = (\text{Direct value}) \times 10$

Command	READ_VIN (88h)															
Format	Direct															
Bit Position	15	14	13	12	11	10	9	8	7	6	5	4	3	2	1	0
Access	R	R	R	R	R	R	R	R	R	R	R	R	R	R	R	R
Function	Two's Complement Integer															

10.58 READ_IIN (89h)

Definition: Returns the synthesized input current reading. 10mA per LSB.

Access: Paged

Data Length in Bytes: 2

Data Format: Direct

Type: Read Only

Units: A

Equation: Read $I_{IN} = (\text{Direct value}) / 100$

Command	READ_IIN (89h)															
Format	Direct															
Bit Position	15	14	13	12	11	10	9	8	7	6	5	4	3	2	1	0
Access	R	R	R	R	R	R	R	R	R	R	R	R	R	R	R	R
Function	Two's Complement Integer															

10.59 READ_VOUT (8Bh)

Definition: Returns the output voltage reading. 1mV per LSB.

Access: Paged

Data Length in Bytes: 2

Data Format: Direct

Type: Read Only

Units: mV

Equation: Read $V_{OUT} = (\text{Direct value})$

Command	READ_VOUT (8Bh)															
Format	Direct															
Bit Position	15	14	13	12	11	10	9	8	7	6	5	4	3	2	1	0
Access	R	R	R	R	R	R	R	R	R	R	R	R	R	R	R	R
Function	Unsigned Integer															

10.60 READ_IOUT (8Ch)

Definition: Returns the output current reading. 0.1A per LSB.

Access: Paged

Data Length in Bytes: 2

Data Format: Direct

Type: Read Only

Units: A

Equation: Read $I_{OUT} = (\text{Direct value}) / 10$

Command	READ_IOUT (8Ch)															
Format	Direct															
Bit Position	15	14	13	12	11	10	9	8	7	6	5	4	3	2	1	0
Access	R	R	R	R	R	R	R	R	R	R	R	R	R	R	R	R
Function	Two's Complement Integer															

10.61 READ_TEMPERATURE_1 (8Dh)

Definition: Returns the temperature reading of the hottest power stage per configured rail. 1°C per LSB.

Access: Paged

Data Length in Bytes: 2

Data Format: Direct

Type: Read Only

Units: °C

Equation: Read Temperature 1 = (Direct value)

Command	READ_TEMPERATURE_1 (8Dh)															
Format	Direct															
Bit Position	15	14	13	12	11	10	9	8	7	6	5	4	3	2	1	0
Access	R	R	R	R	R	R	R	R	R	R	R	R	R	R	R	R
Function	Two's Complement Integer															

10.62 READ_TEMPERATURE_2 (8Eh)

Definition: Returns the internal controller temperature reading. 1°C per LSB.

Access: Global

Data Length in Bytes: 2

Data Format: Direct

Type: Read Only

Units: °C

Equation: Read Temperature 2 = (Direct value)

Command	READ_TEMPERATURE_2 (8Eh)															
Format	Direct															
Bit Position	15	14	13	12	11	10	9	8	7	6	5	4	3	2	1	0
Access	R	R	R	R	R	R	R	R	R	R	R	R	R	R	R	R
Function	Two's Complement Integer															

10.63 READ_TEMPERATURE_3 (8Fh)

Definition: Returns the temperature reading from the TEMP pins. 1°C per LSB.

Access: Paged

Data Length in Bytes: 2

Data Format: Direct

Type: Read Only

Units: °C

Equation: Read Temperature 3 = (Direct value)

Command	READ_TEMPERATURE_3 (8Fh)															
Format	Direct															
Bit Position	15	14	13	12	11	10	9	8	7	6	5	4	3	2	1	0
Access	R	R	R	R	R	R	R	R	R	R	R	R	R	R	R	R
Function	Two's Complement Integer															

10.64 READ_POUT (96h)**Definition:** Returns the output power. 1W per LSB.**Access:** Paged**Data Length in Bytes:** 2**Data Format:** Direct**Type:** Read Only**Units:** W**Equation:** Read P_{OUT} = (Direct value)

Command	READ_POUT (96h)															
Format	Direct															
Bit Position	15	14	13	12	11	10	9	8	7	6	5	4	3	2	1	0
Access	R	R	R	R	R	R	R	R	R	R	R	R	R	R	R	R
Function	Two's Complement Integer															

10.65 READ_PIN (97h)**Definition:** Returns the input power. 1W per LSB.**Access:** Paged**Data Length in Bytes:** 2**Data Format:** Direct**Type:** Read Only**Units:** W**Equation:** READ_PIN = (Direct value)

Command	READ_PIN (97h)															
Format	Direct															
Bit Position	15	14	13	12	11	10	9	8	7	6	5	4	3	2	1	0
Access	R	R	R	R	R	R	R	R	R	R	R	R	R	R	R	R
Function	Two's Complement Integer															

10.66 PMBUS_REVISION (98h)

Definition: Returns the revision of the PMBus specification to which the device is compliant.

Access: Global

Data Length in Bytes: 1

Data Format: Bit Field

Type: Read Only

Default Value: 33h (Part 1 Revision 1.3, Part 2 Revision 1.3)

Command	PMBUS_REVISION (98h)							
Format	Bit Field							
Bit Position	7	6	5	4	3	2	1	0
Access	R	R	R	R	R	R	R	R
Function	See Following Table							
Default Value	0	0	1	1	0	0	1	1

Bits 7:4	Part 1 Revision	Bits 3:0	Part 2 Revision
0000	1.0	0000	1.0
0001	1.1	0001	1.1
0010	1.2	0010	1.2
0011	1.3	0011	1.3

10.67 MFR_ID (99h)

Definition: Stores inventory information during manufacturing of end products. 4 bytes of space with no defined format.

Access: Global

Data Length in Bytes: 4

Data Format: Bit Field

Type: Block R/W

Default Value: 00000000h (empty)

10.68 MFR_MODEL (9Ah)

Definition: Stores inventory information during manufacturing of end products. 4 bytes of space with no defined format.

Access: Global

Data Length in Bytes: 4

Data Format: Bit Field

Type: Block R/W

Default Value: 00000000h (empty)

10.69 MFR_REVISION (9Bh)

Definition: Stores inventory information during manufacturing of end products. 4 bytes of space with no defined format.

Access: Global

Data Length in Bytes: 4

Data Format: Bit Field

Type: Block R/W

Default Value: 00000000h (empty)

10.70 MFR_DATE (9Dh)

Definition: Stores inventory information during manufacturing of end products. 4 bytes of space with no defined format.

Access: Global

Data Length in Bytes: 4

Data Format: Bit Field

Type: Block R/W

Default Value: 00000000h (empty)

10.71 IC_DEVICE_ID (ADh)

Definition: Reports device identification information.

Access: Global

Data Length in Bytes: 4

Data Format: Bit Field

Type: Block Read

Default Value: 49D26300h

Command	IC_DEVICE_ID (ADh)			
Format	Bit Field			
Byte Position	3	2	1	0
Function	MFR Code	ID High Byte	ID Low Byte	Reserved
Default Value	49h	D2h	63h	00h

10.72 IC_DEVICE_REV (AEh)

Definition: Reports device revision information.

Access: Global

Data Length in Bytes: 4

Data Format: Bit Field

Type: Block Read

Default Value: Based on the revision released

Command	IC_DEVICE_REV (AEh)		
Format	Bit Field		
Bit Position	31:24	23:8	7:0
Function	Hardware Revision	Reserved	Firmware Revision

10.73 DMAFIX (C5h)

Definition: Location for DMA access when performing a fixed address memory access. There is no physical storage for this register.

Access: Global

Data Length in Bytes: 4

Data Format: Bit Field

Type: R/W

Default Value: 0000h

Units: N/A

10.74 DMASEQ (C6h)

Definition: Location for DMA access when performing a auto-increment address memory access. A series of reads or writes accesses sequential memory locations, with the value of DMAADDR incremented with each access. The reads or writes can be singular 32-bit transfers or unlimited bursts. There is no physical storage for this register.

Access: Global

Data Length in Bytes: 4

Data Format: Bit Field

Type: R/W

Default Value: 0000h

Units: N/A

10.75 DMAADDR (C7h)

Definition: Specifies the target address of a DMA read or write to system memory. This command is used for indirect access to any system memory.

Access: Global

Data Length in Bytes: 2

Data Format: Bit Field

Type: R/W

Default Value: 0000h

Units: N/A

Command	DMAADDR (C7h)															
Format	Bit Field															
Bit Position	15	14	13	12	11	10	9	8	7	6	5	4	3	2	1	0
Access	R/W	R/W	R/W	R/W	R/W	R/W	R/W	R/W	R/W	R/W	R/W	R/W	R/W	R/W	R/W	R/W
Function	See Following Table															
Default Value	0	0	0	0	0	0	0	0	0	0	0	0	0	0	0	0

Bit	Field Name	Meaning
15:13	REGION	000 - RAM
12:0	DMAADDR	The 13-bit target address

10.76 PEAK_OC_LIMIT (CDh)

Definition: Sets the peak overcurrent limit thresholds for each phase within a rail. 0.1A per LSB.

Access: Paged

Data Length in Bytes: 2

Data Format: Direct

Type: R/W

Equation: Peak Phase OC Limit = (Direct value) / 10

Units: A

Default Value: 0258h (60A)

Range: Depends on configuration

Command	PEAK_OC_LIMIT (CDh)															
Format	Direct															
Bit Position	15	14	13	12	11	10	9	8	7	6	5	4	3	2	1	0
Access	R/W	R/W	R/W	R/W	R/W	R/W	R/W	R/W	R/W	R/W	R/W	R/W	R/W	R/W	R/W	R/W
Function	Two's Complement Integer															
Default Value	0	0	0	0	0	0	1	0	0	1	0	1	1	0	0	0

10.77 PEAK_UC_LIMIT (CEh)

Definition: Sets the peak undercurrent limit thresholds for each phase within a rail. 0.1A per LSB.

Access: Paged

Data Length in Bytes: 2

Data Format: Direct

Type: R/W

Equation: Peak Phase UC Limit = (Direct value) / 10

Units: A

Default Value: FDA8 (-60A)

Range: Depends on configuration

Command	PEAK_UC_LIMIT (CEh)															
Format	Direct															
Bit Position	15	14	13	12	11	10	9	8	7	6	5	4	3	2	1	0
Access	R/W	R/W	R/W	R/W	R/W	R/W	R/W	R/W	R/W	R/W	R/W	R/W	R/W	R/W	R/W	R/W
Function	Two's Complement Integer															
Default Value	1	1	1	1	1	1	0	1	1	0	1	0	1	0	0	0

10.78 VMON_ON (D0h)

Definition: Sets the VMON pin input voltage rising threshold at which the output can be enabled. 10mV per LSB.

Access: Global

Data Length in Bytes: 2

Data Format: Direct

Type: R/W

Default Value: 1C2h (4.5V)

Units: mV

Equation: VMON On = (Direct value) x 10

Range: 0mV to 32767mV

Command	VMON_ON (D0h)																
Format	Direct																
Bit Position	15	14	13	12	11	10	9	8	7	6	5	4	3	2	1	0	
Access	R/W	R/W	R/W	R/W	R/W	R/W	R/W	R/W	R/W	R/W	R/W	R/W	R/W	R/W	R/W	R/W	
Function	Unsigned Integer																
Default Value	0	0	0	0	0	0	0	0	1	1	1	0	0	0	0	1	0

10.79 VMON_OFF (D1h)

Definition: Sets the VMON pin input voltage falling threshold at which the output disables. 10mV per LSB.

Access: Global

Data Length in Bytes: 2

Data Format: Direct

Type: R/W

Default Value: 190h (4V)

Units: mV

Equation: VMON_OFF = (Direct value) x 10

Range: 0mV to 32767mV

Command	VMON_OFF (D1h)															
Format	Direct															
Bit Position	15	14	13	12	11	10	9	8	7	6	5	4	3	2	1	0
Access	R/W	R/W	R/W	R/W	R/W	R/W	R/W	R/W	R/W	R/W	R/W	R/W	R/W	R/W	R/W	R/W
Function	Unsigned Integer															
Default Value	0	0	0	0	0	0	0	0	1	1	0	0	1	0	0	0

10.80 COMPPROP (DDh)

Definition: Sets the proportional gain of the compensation loop.

Access: Paged

Data Length in Bytes: 4

Data Format: Bit Field

Type: R/W

Default Value: D90907C4h

Command	COMPPROP (DDh)															
Format	Bit Field															
Bit Position	31	30	29	28	27	26	25	24	23	22	21	20	19	18	17	16
Access	R/W	R/W	R/W	R/W	R/W	R/W	R/W	R/W	R/W	R/W	R/W	R/W	R/W	R/W	R/W	R/W
Function	See Following Table															
Default Value	1	1	0	1	1	0	0	1	0	0	0	0	1	0	0	1
Bit Position	15	14	13	12	11	10	9	8	7	6	5	4	3	2	1	0
Access	R/W	R/W	R/W	R/W	R/W	R/W	R/W	R/W	R/W	R/W	R/W	R/W	R/W	R/W	R/W	R/W
Function	See Following Table															
Default Value	0	0	0	0	0	1	1	1	1	1	0	0	0	1	0	0

Bit Position	Function
31:28	Proportional gain mantissa >8 phase override, use normal P gain if value = 0 and shift = 0
27:25	Proportional gain exponent >8 phase override, use normal P gain if value = 0 and shift = 0
24:21	Proportional gain mantissa 2-phase override, use normal P gain if value = 0 and shift = 0
20	Not Used
19:17	Proportional gain exponent 2-phase override, use normal P gain if value = 0 and shift = 0
16:13	Proportional gain mantissa 1-phase override, use normal P gain if value = 0 and shift = 0
12	Not Used
11:9	Proportional gain exponent 1-phase override, use normal P gain if value = 0 and shift = 0
8	FIR filter length, 0 = none or 1 = ON Must be set if using D term for PID, optional if not using D term
7:4	Proportional gain mantissa is (value/8), all phase counts, if value = 0 gain is 0
3	Not Used
2:0	Proportional gain exponent is $2^{(\text{shift}-3)}$, all phase counts, if value = 0 and shift = 0 gain is 0

10.81 COMPINTEG (DEh)

Definition: Sets the integral gain of the compensation loop.

Access: Paged

Data Length in Bytes: 4

Data Format: Bit Field

Type: R/W

Default Value: 00A9h

Command	COMPINTEG (DEh)															
Format	Bit Field															
Bit Position	31	30	29	28	27	26	25	24	23	22	21	20	19	18	17	16
Access	R/W	R/W	R/W	R/W	R/W	R/W	R/W	R/W	R/W	R/W	R/W	R/W	R/W	R/W	R/W	R/W
Function	See Following Table															
Default Value	0	0	0	0	0	0	0	0	0	0	0	0	0	0	0	0
Bit Position	15	14	13	12	11	10	9	8	7	6	5	4	3	2	1	0
Access	R/W	R/W	R/W	R/W	R/W	R/W	R/W	R/W	R/W	R/W	R/W	R/W	R/W	R/W	R/W	R/W
Function	See Following Table															
Default Value	0	0	0	0	0	0	0	0	1	0	1	0	1	0	0	1

Bit Position	Function
31:16	Not Used
15:12	Delay time for stepping down gain towards shift. Dcm when in DCM, in 16*clkTs per gain step
11:8	Gain when in DCM for a while
7:4	Maximum gain used when Integral movement detected Gain is $2^{(-shift-1)}$
3:0	Gain is $2^{(-shift-1)}$

10.82 COMPIDFF (DFh)

Definition: Sets the differential gain of the compensation loop.

Access: Paged

Data Length in Bytes: 2

Data Format: Bit Field

Type: R/W

Default Value: 0000h

Command	COMPIDFF (DFh)															
Format	Bit Field															
Bit Position	15	14	13	12	11	10	9	8	7	6	5	4	3	2	1	0
Access	R	R	R/W	R/W	R	R	R/W	R/W	R	R/W	R/W	R/W	R/W	R/W	R/W	R/W
Function	See Following Table															
Default Value	0	0	0	0	0	0	0	0	0	0	0	0	0	0	0	0

Bit Number	Setting
15:13	Reserved
12	FIR filter length 0 or 1
11:8	Diff gain mantissa 1-phase override, use normal P gain if value = 0 and shift = 0
7:6	Diff gain exponent 1-phase override, use normal P gain if value = 0 and shift = 0
5:2	Differentiator gain mantissa (value/8)
1:0	Differentiator gain exponent $2^{(\text{shift}+1 + \text{P-shift})}$ range 0:3

10.83 COMPCFB (E0h)

Definition: Sets the AC current feedback gain of the compensation loop.

Access: Paged

Data Length in Bytes: 2

Data Format: Bit Field

Type: R/W

Default Value: 0560h

Command	COMPCFB (E0h)															
Format	Bit Field															
Bit Position	15	14	13	12	11	10	9	8	7	6	5	4	3	2	1	0
Access	R/W	R/W	R/W	R/W	R/W	R/W	R/W	R/W	R/W	R/W	R/W	R/W	R/W	R/W	R/W	R/W
Function	See Following Table															
Default Value	0	0	0	0	0	1	0	1	0	1	1	0	0	0	0	0

Bit Number	Function
15:8	High-pass filter coefficient for current feedback
7:0	Current feedback gain, low droop cases

10.84 HS_BUS_CURRENT_SCALE (E3h)

Definition: Sets the scaling value for the high speed bus output current reporting. 16 bits with 14 fractional bits. A value of 0x4000 is a scale factor of 1.0. A value of 0x0000 is also interpreted as a scale factor of 1.0.

Access: Paged

Data Length in Bytes: 2

Data Format: Direct

Type: R/W

Default Value: 4000h (1.0)

Units: Scale Factor

Equation: HS Bus Current Scale = (Direct value) * 2⁻¹⁴

Range: 0 to 4.0

Command	HS_BUS_CURRENT_SCALE (E3h)															
Format	Direct															
Bit Position	15	14	13	12	11	10	9	8	7	6	5	4	3	2	1	0
Access	R/W	R/W	R/W	R/W	R/W	R/W	R/W	R/W	R/W	R/W	R/W	R/W	R/W	R/W	R/W	R/W
Function	Unsigned Integer															
Default Value	0	1	0	0	0	0	0	0	0	0	0	0	0	0	0	0

10.85 PHASE_CURRENT (E4h)

Definition: Returns the individual phase current reading for the phase selected in PHASE (04h). 0.1A per LSB.

Access: Global

Data Length in Bytes: 2

Data Format: Direct

Type: Read Only

Units: A

Equation: Phase current = (Direct value) / 10

Command	PHASE_CURRENT (E4h)															
Format	Direct															
Bit Position	15	14	13	12	11	10	9	8	7	6	5	4	3	2	1	0
Access	R	R	R	R	R	R	R	R	R	R	R	R	R	R	R	R
Function	Two's Complement Integer															

10.86 PHASE_TEMPERATURE (E5h)

Definition: Returns the individual phase temperature reading for the phase selected in PHASE (04h). 1°C per LSB.

Access: Global

Data Length in Bytes: 2

Data Format: Direct

Type: Read Only

Units: °C

Equation: Phase Temperature = (Direct value)

Command	PHASE_TEMPERATURE (E5h)															
Format	Direct															
Bit Position	15	14	13	12	11	10	9	8	7	6	5	4	3	2	1	0
Access	R	R	R	R	R	R	R	R	R	R	R	R	R	R	R	R
Function	Two's Complement Integer															

10.87 PEAK_OCUC_COUNT (E9h)

Definition: Sets the number of consecutive switch cycles that can exceed the peak per-phase overcurrent limit threshold before generating a fault within a rail. A value of 0 disables the fault shutdown and produces a constant current effect.

Access: Paged

Data Length in Bytes: 2

Data Format: Bit Field

Type: R/W

Equation: Peak UC Count = (Direct value [15:8]), Peak OC Count = (Direct value [7:0])

Units: Cycles

Default Value: 0606h (6 cycles OC and 6 cycles UC)

Range: 1 cycle - 255 cycles

Command	PEAK_OCUC_COUNT (E9h)															
Format	Bit Field															
Bit Position	15	14	13	12	11	10	9	8	7	6	5	4	3	2	1	0
Access	R/W	R/W	R/W	R/W	R/W	R/W	R/W	R/W	R/W	R/W	R/W	R/W	R/W	R/W	R/W	R/W
Function	See Following Table															
Default Value	0	0	0	0	0	1	1	0	0	0	0	0	0	1	1	0

Bit Number	Meaning
15:8	Number of consecutive switch cycles exceeding peak UC limit before fault
7:0	Number of consecutive switch cycles exceeding peak OC limit before fault

10.88 SLOW_IOUT_OC_LIMIT (EAh)

Definition: Sets the slow sum output overcurrent fault threshold. 100mA per LSB. A value of 0 disables this function.

Access: Paged

Data Length in Bytes: 2

Data Format: Direct

Type: R/W

Default Value: C8h (20A)

Units: A

Equation: Slow I_{OUT} OC Limit = (Direct value) / 10

Range: 0A to 3276A

Command	SLOW_IOUT_OC_LIMIT (EAh)																
Format	Direct																
Bit Position	15	14	13	12	11	10	9	8	7	6	5	4	3	2	1	0	
Access	R/W	R/W	R/W	R/W	R/W	R/W	R/W	R/W	R/W	R/W	R/W	R/W	R/W	R/W	R/W	R/W	
Function	Two's Complement Integer																
Default Value	0	0	0	0	0	0	0	0	0	1	1	0	0	1	0	0	0

10.89 FAST_OC_FILT_COUNT (EBh)

Definition: Sets the fast sum output overcurrent fault filter settings.

Access: Paged

Data Length in Bytes: 2

Data Format: Bit Field

Type: R/W

Default Value: 0696h (Filter = 10.7 μ s, Delay = 100 μ s)

Command	FAST_OC_FILT_COUNT (EBh)															
Format	Bit Field															
Bit Position	15	14	13	12	11	10	9	8	7	6	5	4	3	2	1	0
Access	R/W	R/W	R/W	R/W	R/W	R/W	R/W	R/W	R/W	R/W	R/W	R/W	R/W	R/W	R/W	R/W
Function	See Following Table															
Default Value	0	0	0	0	0	1	1	0	1	0	0	1	0	1	1	0

Bit Number	Purpose	Setting
15:12	Not Used	Not used
11:8	Filter Setting	Time constant = 166.7ns*2 ^{direct value} . Range is 167ns to 5.46ms.
7:0	Delay Setting	Delay 0.667 μ s* direct value before a fault is generated. Range is 0 μ s to 170 μ s.

10.90 SLOW_OC_FILT_COUNT (ECh)

Definition: Sets the slow sum output overcurrent fault filter settings.

Access: Paged

Data Length in Bytes: 2

Data Format: Bit Field

Type: R/W

Default Value: 0606h (Filter = 10.7 μ s, Delay = 1024 μ s)

Command	SLOW_OC_FILT_COUNT (ECh)															
Format	Bit Field															
Bit Position	15	14	13	12	11	10	9	8	7	6	5	4	3	2	1	0
Access	R/W	R/W	R/W	R/W	R/W	R/W	R/W	R/W	R/W	R/W	R/W	R/W	R/W	R/W	R/W	R/W
Function	See Following Table															
Default Value	0	0	0	0	0	1	1	0	0	0	0	0	0	1	1	0

Bit Number	Purpose	Setting
15:12	Not Used	Not used
11:8	Filter Setting	Time constant = 166.7ns*2 ^{direct value} . Range is 167ns to 5.46ms.
7:0	Delay Setting	Delay 170.7 μ s* direct value before a fault is generated. Range is 0 μ s to 43.5ms.

10.91 LOOPCFG (F0h)

Definition: Configures various rail settings. To make a change, read the value, modify only the desired bits, and write the value while preserving the bit settings.

Access: Paged

Data Length in Bytes: 4

Data Format: Bit Field

Type: R/W

Default Value: 102031F6h

Command	LOOPCFG (F0h)															
Format	Bit Field															
Bit Position	31	30	29	28	27	26	25	24	23	22	21	20	19	18	17	16
Access	R/W	R/W	R/W	R/W	R/W	R/W	R/W	R/W	R/W	R/W	R/W	R/W	R/W	R/W	R/W	R/W
Function	See Following Table															
Default Value	0	0	0	1	0	0	0	0	0	0	1	0	0	0	0	0
Bit Position	15	14	13	12	11	10	9	8	7	6	5	4	3	2	1	0
Access	R/W	R/W	R/W	R/W	R/W	R/W	R/W	R/W	R/W	R/W	R/W	R/W	R/W	R/W	R/W	R/W
Function	See Following Table															
Default Value	0	0	1	1	0	0	0	1	1	1	1	1	0	1	1	0

Bit Position	Field	Function
31	Not Used	Not used
30:29	Reserved	Reserved
28	Diode Emulation Mode	1 = Enable diode emulation for power_mode 3
27:12	Reserved	Reserved
11:8	Minimum Phase Count	Minimum phase count, 0-2
7	Reserved	Reserved
6	Diode Emulation Enable	1 = Enable diode emulation
5:4	Reserved	Reserved
3:1	Reserved	Reserved
0	APD enable	1 = Enable auto phase add/drop

10.92 RESTORE_CFG (F2h)

Definition: Identifies the user configuration ID to be restored from NVM and loads the store settings into the active memory of the device. This command should only be used while all outputs are disabled. Restore takes 3ms to complete.

Access: Global

Data Length in Bytes: 1

Data Format: Bit Field

Type: R/W

Default Value: 00h

Command	RESTORE_CFG (F2h)							
Format	Bit Field							
Bit Position	7	6	5	4	3	2	1	0
Access	R	R	R	R	R/W	R/W	R/W	R/W
Function	See Following Table							
Default Value	0	0	0	0	0	0	0	0

Bit Number	Status Bit Name	Meaning
7:4	Reserved	Reserved
3:0	CONFIG	Selected user configuration ID to restore, 0-15.

11. Revision History

Rev.	Date	Description
1.00	Oct. 1.20	Initial release

12. Package Outline Drawing

For the most recent package outline drawing, see [L32.4x4D](#).

L32.4x4D
 32 LEAD THIN QUAD FLAT NO-LEAD PLASTIC PACKAGE
 Rev 2, 10/16

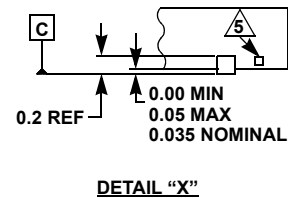
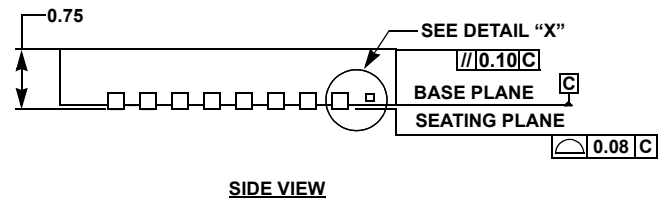
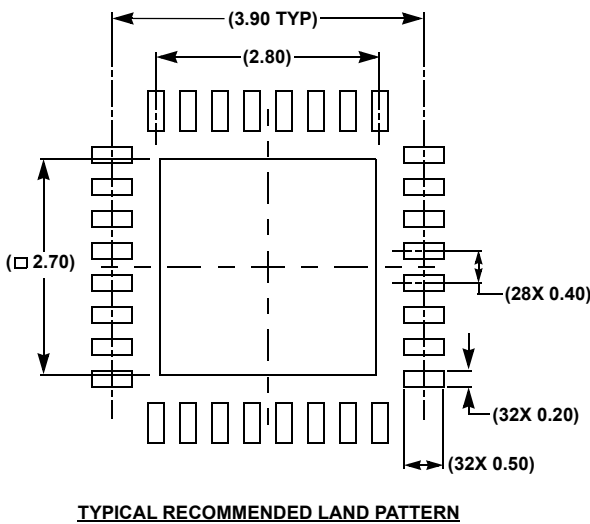
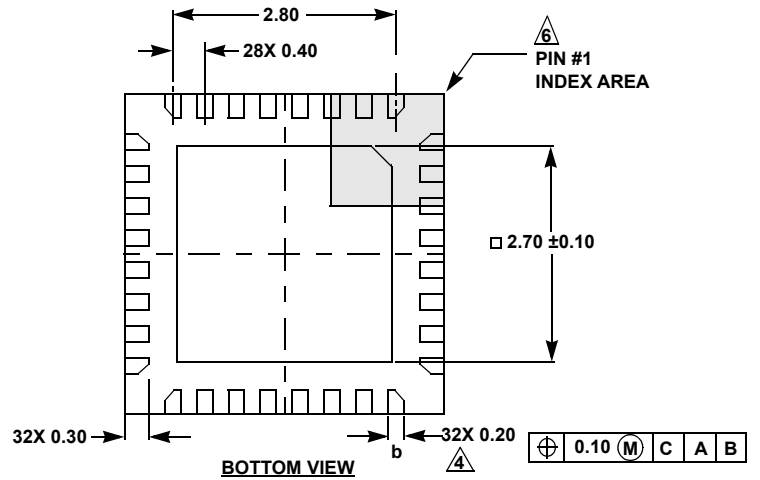
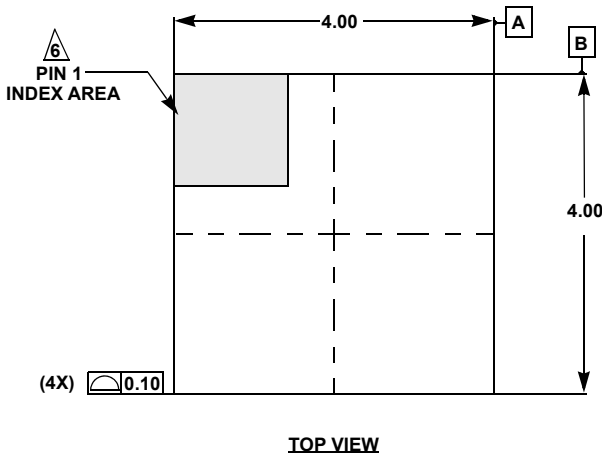

NOTES:

1. Dimensions are in millimeters.
 Dimensions in () for Reference Only.
2. Dimensioning and tolerancing conform to ASME Y14.5m-1994.
3. Unless otherwise specified, tolerance: Decimal ± 0.05 .
4. Dimension b applies to the metallized terminal and is measured between 0.15mm and 0.25mm from the terminal tip.
5. Tiebar shown (if present) is a non-functional feature.
6. The configuration of the pin #1 identifier is optional, but must be located within the zone indicated. The pin #1 identifier may be either a mold or mark feature.

IMPORTANT NOTICE AND DISCLAIMER

RENESAS ELECTRONICS CORPORATION AND ITS SUBSIDIARIES (“RENESAS”) PROVIDES TECHNICAL SPECIFICATIONS AND RELIABILITY DATA (INCLUDING DATASHEETS), DESIGN RESOURCES (INCLUDING REFERENCE DESIGNS), APPLICATION OR OTHER DESIGN ADVICE, WEB TOOLS, SAFETY INFORMATION, AND OTHER RESOURCES “AS IS” AND WITH ALL FAULTS, AND DISCLAIMS ALL WARRANTIES, EXPRESS OR IMPLIED, INCLUDING, WITHOUT LIMITATION, ANY IMPLIED WARRANTIES OF MERCHANTABILITY, FITNESS FOR A PARTICULAR PURPOSE, OR NON-INFRINGEMENT OF THIRD PARTY INTELLECTUAL PROPERTY RIGHTS.

These resources are intended for developers skilled in the art designing with Renesas products. You are solely responsible for (1) selecting the appropriate products for your application, (2) designing, validating, and testing your application, and (3) ensuring your application meets applicable standards, and any other safety, security, or other requirements. These resources are subject to change without notice. Renesas grants you permission to use these resources only for development of an application that uses Renesas products. Other reproduction or use of these resources is strictly prohibited. No license is granted to any other Renesas intellectual property or to any third party intellectual property. Renesas disclaims responsibility for, and you will fully indemnify Renesas and its representatives against, any claims, damages, costs, losses, or liabilities arising out of your use of these resources. Renesas' products are provided only subject to Renesas' Terms and Conditions of Sale or other applicable terms agreed to in writing. No use of any Renesas resources expands or otherwise alters any applicable warranties or warranty disclaimers for these products.

(Rev.1.0 Mar 2020)

Corporate Headquarters

TOYOSU FORESIA, 3-2-24 Toyosu,
Koto-ku, Tokyo 135-0061, Japan
www.renesas.com

Contact Information

For further information on a product, technology, the most up-to-date version of a document, or your nearest sales office, please visit:
www.renesas.com/contact/

Trademarks

Renesas and the Renesas logo are trademarks of Renesas Electronics Corporation. All trademarks and registered trademarks are the property of their respective owners.