

AC / DC converter

BP5041A / BP5041A5 / BP5041A15

The BP5041A, BP5041A5 and BP5041A15 are AC/DC converters which can be used to supply DC output from a commercial power supply (200 to 230V AC). Using these modules enable simple, easy drive of microcomputers, LEDs, and other electronic components without using a transformer. They also allow set PCBs to be kept compact and lightweight, with extremely few attachments.

These products can accommodate the 200V AC power supplies used as household power supplies in Asia and Europe, as well as in buildings and facilities in Japan.

●Applications

Power supply circuits for vacuum cleaners, refrigerators, washing machines, air conditioners, irons, electric carpets, cordless telephones, air purifiers, humidifiers, dehumidifiers, home bakery devices, electric crock pots and rice cookers, illumination devices and other small household appliances, as well as power supply circuits for gas leakage sensors, and other industrial products

●Features

- 1) Elimination of a transformer enables compact, lightweight power supply boards.
- 2) Wide input voltage range. (226 to 390V DC for DC voltage conversion, 160 to 276V for AC voltage conversion)
- 3) DC power supplies can be easily configured, with few attachments.
- 4) Because no transformer is used, the power supply board is less vulnerable to splitting or cracking from impact or shock.
- 5) Allow easy assemblage of components.

●List of the BP5041A series

Parameter	BP5041A5	BP5041A	BP5041A15	Unit
Power supply voltage	226~390	226~390	226~390	V
Output voltage	5	12	15	V
Output current	100	100	80	mA

●Absolute maximum ratings (Ta = 25°C)

Parameter	Symbol	Limits			Unit
		BP5041A5	BP5041A	BP5041A15	
Power supply voltage	V _{IN}	390	390	390	V
Output current	I _o	100	100	80	mA
Operating temperature range	T _{opr}	-25~+80	-25~+80	-25~+80	°C
Storage temperature range	T _{stg}	-25~+105	-25~+105	-25~+105	°C

BP5041A / BP5041A5 / BP5041A15

Power Module

●Recommended operating conditions

Parameter	Symbol	Min.	Typ.	Max.	Unit
Power supply voltage	V_{IN}	226	282	390	$V_{(DC)}$

●Electrical characteristics (Unless otherwise noted, $T_a = 25^\circ\text{C}$)

BP5041A

Parameter	Symbol	Min.	Typ.	Max.	Unit	Conditions
Input voltage	V_{IN}	226	282	390	V	DC
Output voltage	V_o	11	12	13	V	$V_{IN} = 282\text{V}$, $I_o = 50\text{mA}$
Output current	I_o	0	–	100	V	$V_{IN} = 282\text{V}$ *1
Line regulation	V_r	–	0.02	0.15	V	$V_{IN} = 226\text{V}\sim 390\text{V}$, $I_o = 50\text{mA}$
Load regulation	V_l	–	0.05	0.15	V	$V_{IN} = 282\text{V}$, $I_o = 0\sim +50\text{mA}$
Output ripple voltage	V_p	–	0.05	0.15	V_{PP}	$V_{IN} = 282\text{V}$, $I_o = 50\text{mA}$ *2
Conversion efficiency	η	50	62	–	%	$V_{IN} = 282\text{V}$, $I_o = 100\text{mA}$

BP5041A5

Parameter	Symbol	Min.	Typ.	Max.	Unit	Conditions
Input voltage	V_{IN}	226	282	390	V	DC
Output voltage	V_o	4.7	5	5.3	V	$V_{IN} = 282\text{V}$, $I_o = 50\text{mA}$
Output current	I_o	0	–	100	mA	$V_{IN} = 282\text{V}$ *1
Line regulation	V_r	–	0.05	0.15	V	$V_{IN} = 226\text{V}\sim 358\text{V}$, $I_o = 50\text{mA}$
Load regulation	V_l	–	0.05	0.15	V	$V_{IN} = 282\text{V}$, $I_o = 0\sim +50\text{mA}$
Output ripple voltage	V_p	–	0.05	0.15	V_{PP}	$V_{IN} = 282\text{V}$, $I_o = 50\text{mA}$ *2
Conversion efficiency	η	35	48	–	%	$V_{IN} = 282\text{V}$, $I_o = 100\text{mA}$

BP5041A15

Parameter	Symbol	Min.	Typ.	Max.	Unit	Conditions
Input voltage	V_{IN}	226	282	390	V	DC
Output voltage	V_o	14	15	16	V	$V_{IN} = 282\text{V}$, $I_o = 50\text{mA}$
Output current	I_o	0	–	80	mA	$V_{IN} = 282\text{V}$ *1
Line regulation	V_r	–	0.02	0.15	V	$V_{IN} = 226\text{V}\sim 358\text{V}$, $I_o = 50\text{mA}$
Load regulation	V_l	–	0.05	0.15	V	$V_{IN} = 282\text{V}$, $I_o = 0\sim +50\text{mA}$
Output ripple voltage	V_p	–	0.05	0.15	V_{PP}	$V_{IN} = 282\text{V}$, $I_o = 50\text{mA}$ *2
Conversion efficiency	η	50	64	–	%	$V_{IN} = 282\text{V}$, $I_o = 80\text{mA}$

*1 Maximum output current varies depending on ambient temperature; please refer to derating curve.
 *2 Spike noise is not included in output ripple voltage.

BP5041A / BP5041A5 / BP5041A15

Power Module

● Pin descriptions

Pin No.	Pin name
1	V _{OUT}
3	N.C.
5	COMMON
7	N.C.
10	V _{IN}

Pins 2, 4, 6, 8, 9 are removed.

● Measurement circuit

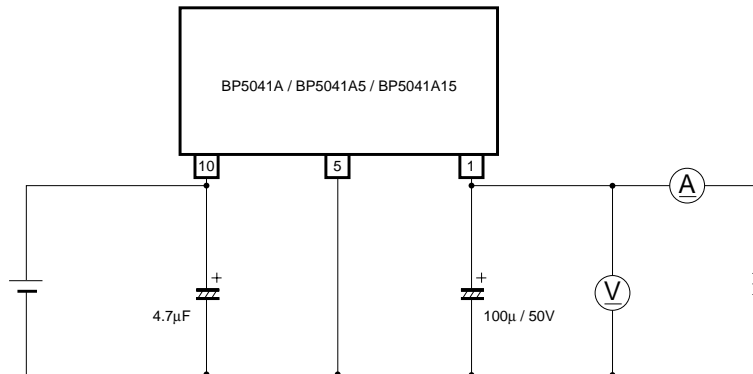

Use a low-impedance product for switching power supplies for the output capacitor.

Fig.1

● Application example

Half wave rectifier circuit

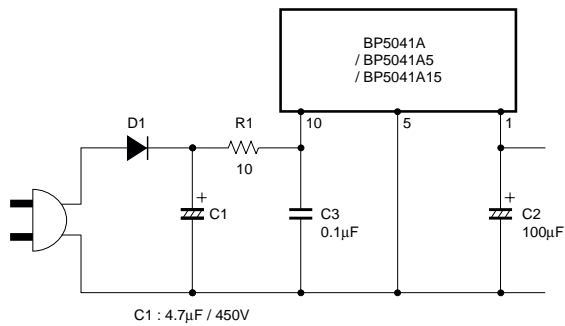

Full wave rectifier circuit

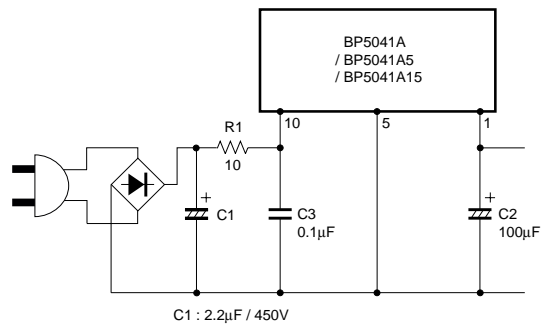

C1, C2 (Low-impedance capacitors)

Fig.2

Power Module

Application example for inventor lighting

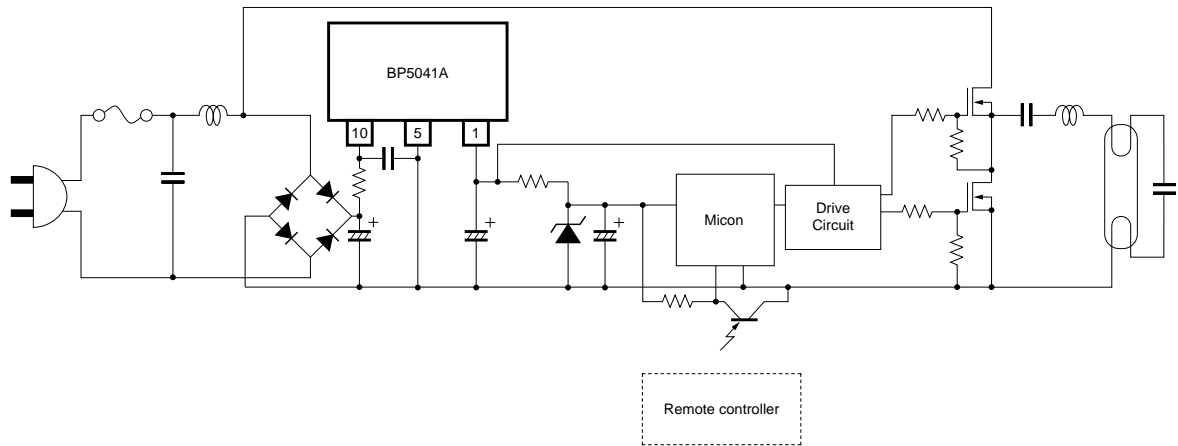

Fig.3

●Selecting attachments

(1) Diodes

The rectifying diodes used should fulfill the following conditions.

In the absolute maximum ratings, the reverse peak voltage should be 700V or higher, the average rectifying current should be 0.5A or higher, and the forward peak surge current should be 20A or higher.

(2) Smoothing capacitor for input pin

A capacitor with a larger capacitance produces a more stable output voltage. A capacitor of between 3.3 μ F and 10 μ F is recommended. The capacitor should have a withstanding voltage of at least 400V.

(3) Smoothing capacitor for output pin

This capacitor should have a low ESR. Low-impedance capacitors designed for switching power supplies are especially suitable. The ESR of the capacitor affects the output ripple voltage.

(4) CR filter should be placed between R1 and C3 in order to lower the fine-noise voltage; R1 should be 1/4W and 10 Ω ~ 22 Ω , C3 should be a film capacitor and 400V or higher. Make sure to place C3 as near as possible to the modules.

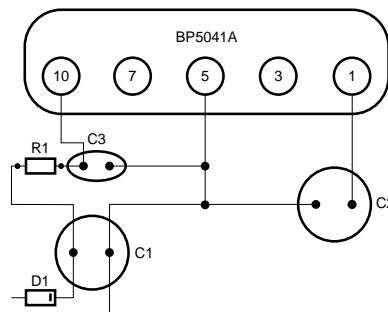

Fig.4

Power Module

(5) Pin noise voltage

The measurement circuit diagram below (Fig.6) was used in the test whose results are shown in Fig.5.

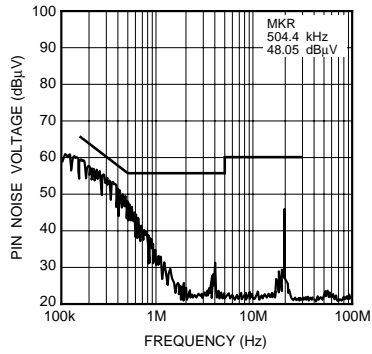

Fig.5 Pin noise voltage

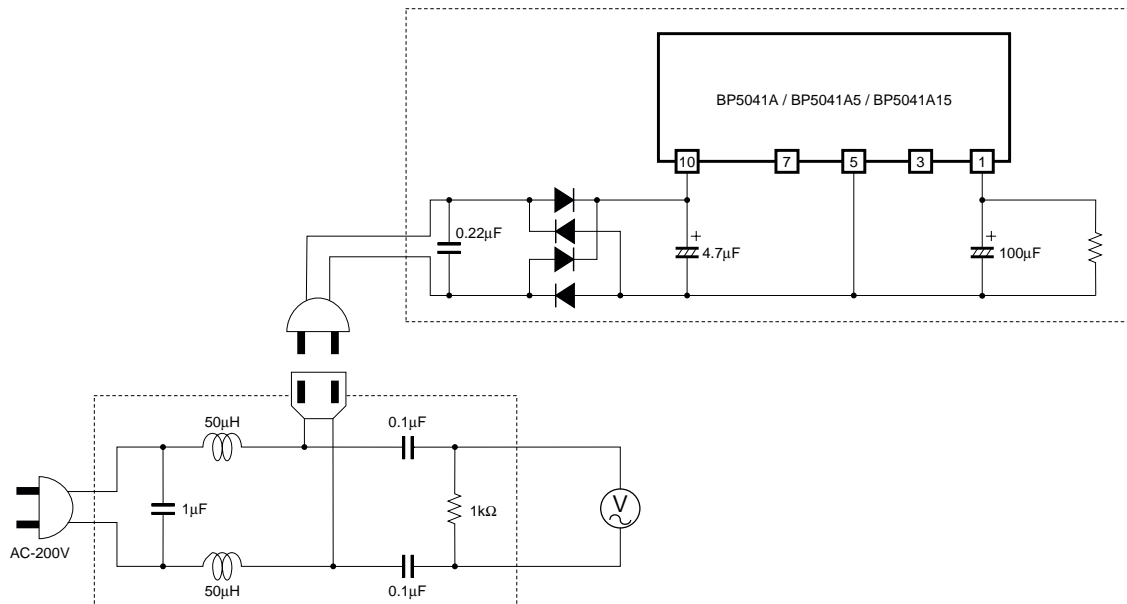

Fig.6

Power Module

●Operation notes

- (1) The output current needs to be reduced as the ambient temperature rises.
- (2) Lead pins should be securely soldered. Avoid subjecting these products to strong impact.
- (3) Over current and shorted circuit

The over current limit is a drooping model of approximately 130mA. At 25°C, if over output current of higher than 100mA is produced intermittently, or is produced continuously for a total of one minute or longer, these products are vulnerable to damage. If there is any danger of the load being shorted or over current being produced, always use a protective device such as a fuse. The fuse should have a fusion current of 0.5A.
- (4) Regulations on Electrical Appliances

As stand-alone products, they are not subject to regulations governing electrical appliances. Please be aware, therefore, that applications must be submitted for sets and not for individual products.
- (5) Insulation

These products are not insulated on the primary and secondary sides, and there is a danger of electrical shock if they are touched.
- (6) Connections with other devices

Devices using these products should not be connected to other devices. If connected, insulation should be provided.
- (7) I / O external capacitors should be placed as near as possible to the connection pins.

●Electrical characteristic curves

BP5041A5

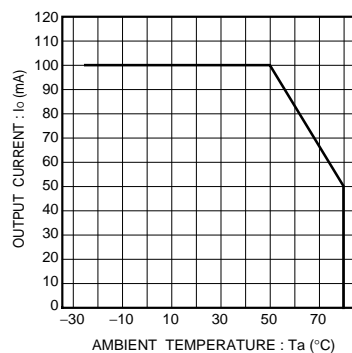

Fig.7 Derating curve

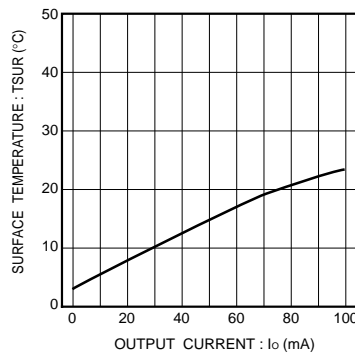

Fig.8 Surface temperature rise

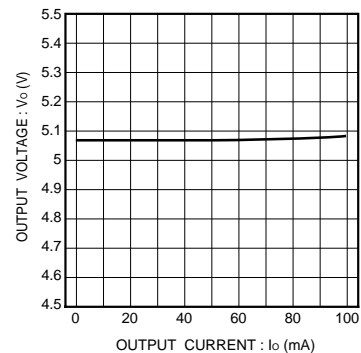

Fig.9 Output characteristic

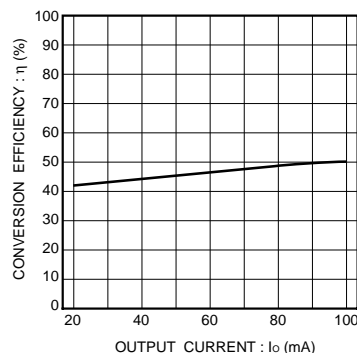

Fig.10 Conversion efficiency

Power Module

BA5041A

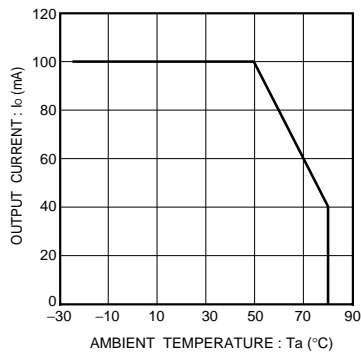

Fig.11 Derating curve

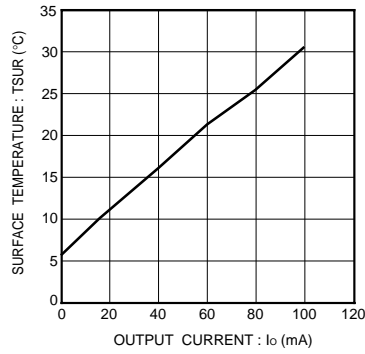

Fig.12 Surface temperature rise

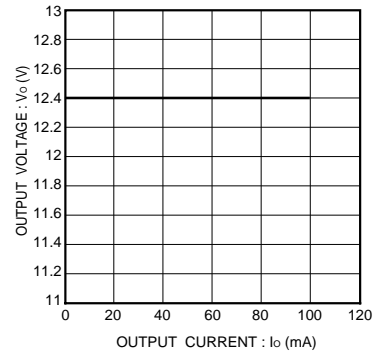

Fig.13 Output characteristic

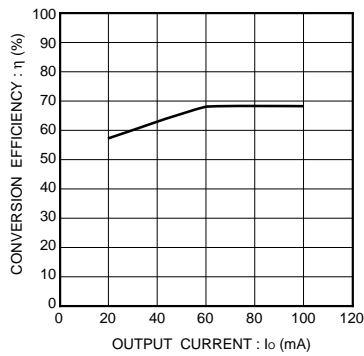

Fig.14 Conversion efficiency

BA5041A15

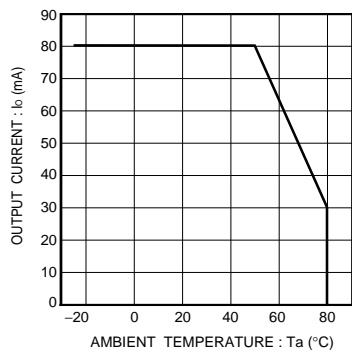

Fig.15 Derating curve

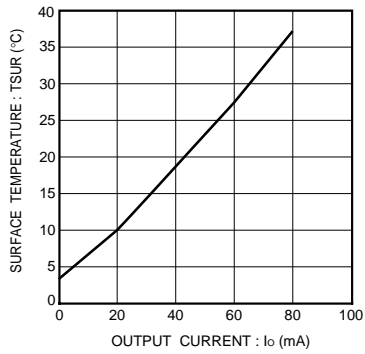

Fig.16 Surface temperature rise

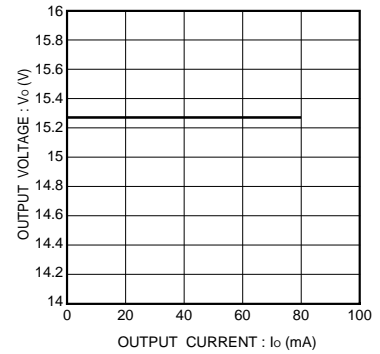

Fig.17 Output characteristic

Power Module

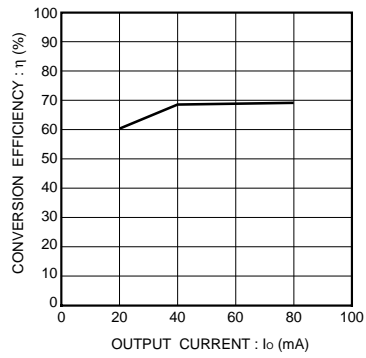
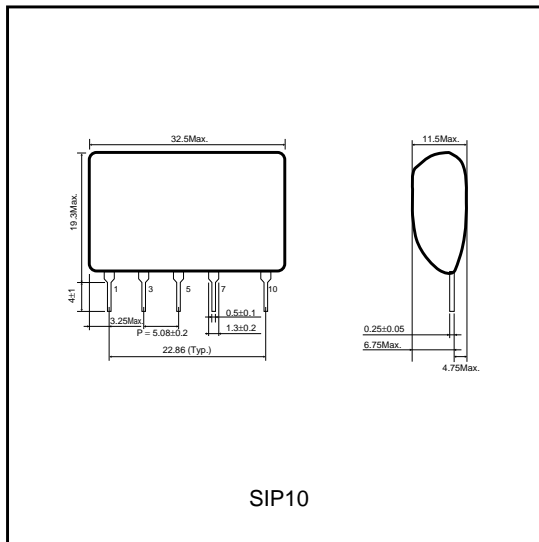

Fig.18 Conversion efficiency

●External dimensions (Units : mm)



Notes

- No technical content pages of this document may be reproduced in any form or transmitted by any means without prior permission of ROHM CO.,LTD.
- The contents described herein are subject to change without notice. The specifications for the product described in this document are for reference only. Upon actual use, therefore, please request that specifications to be separately delivered.
- Application circuit diagrams and circuit constants contained herein are shown as examples of standard use and operation. Please pay careful attention to the peripheral conditions when designing circuits and deciding upon circuit constants in the set.
- Any data, including, but not limited to application circuit diagrams information, described herein are intended only as illustrations of such devices and not as the specifications for such devices. ROHM CO.,LTD. disclaims any warranty that any use of such devices shall be free from infringement of any third party's intellectual property rights or other proprietary rights, and further, assumes no liability of whatsoever nature in the event of any such infringement, or arising from or connected with or related to the use of such devices.
- Upon the sale of any such devices, other than for buyer's right to use such devices itself, resell or otherwise dispose of the same, no express or implied right or license to practice or commercially exploit any intellectual property rights or other proprietary rights owned or controlled by
- ROHM CO., LTD. is granted to any such buyer.
- Products listed in this document use silicon as a basic material.
Products listed in this document are no antiradiation design.

The products listed in this document are designed to be used with ordinary electronic equipment or devices (such as audio visual equipment, office-automation equipment, communications devices, electrical appliances and electronic toys).

Should you intend to use these products with equipment or devices which require an extremely high level of reliability and the malfunction of which would directly endanger human life (such as medical instruments, transportation equipment, aerospace machinery, nuclear-reactor controllers, fuel controllers and other safety devices), please be sure to consult with our sales representative in advance.

About Export Control Order in Japan

Products described herein are the objects of controlled goods in Annex 1 (Item 16) of Export Trade Control Order in Japan.

In case of export from Japan, please confirm if it applies to "objective" criteria or an "informed" (by MITI clause) on the basis of "catch all controls for Non-Proliferation of Weapons of Mass Destruction.