

NOTES

- ① 材料及び仕上げ(めっき仕様) : TABLE1参照
MATERIAL AND FINISES:SEE TABLE 1
2. 製品仕様 : 2147190000-PS 000
PRODUCT SPECIFICATION : 2147190000-PS 000
3. 梱包仕様 : 2147219200-SPK 200
PACKING SPECIFICATION : 2147219200-SPK 200
4. 嵌合相手 : 214719 SERIES
MATE WITH : 214719 SERIES
5. アプリケーション仕様書
(コネクタ取扱い説明書) : 2166940000-AS 000
APPLICATION SPECIFICATION
(CONNECTOR MANUAL) : 2166940000-AS 000

6. 端子テール部及びネイルの平坦度 : 0.1MAX.
TAIL AND NAIL COPLANARITY TO BE 0.1 MAX.
極数/2 = 偶数に適応
- ⑦ APPLY FOR CIRCUIT SIZE / 2 = EVEN
発注番号(製品番号) : SHEET 4の製品一覧を参照ください
- ⑧ ORDER No (MATERIAL No) :
REFER TO SHEET 4 FOR PRODUCT LIST

214721 00**

シリーズ番号

極数

SERIES No.

CIRCUIT SIZE

9. 本製品のプラスチック部に黒点、白点等が確認される場合や色合いが異なる場合がありますが、製品機能に影響はありません。
THERE IS NO INFLUENCE IN THE PRODUCT PERFORMANCE THOUGH THE BLACK AND WHITE SPOT ETC.
MIGHT BE CONFIRMED TO THE PLASTIC PART OF THIS PRODUCT AND THE SHADE MIGHT BE DIFFERENT.

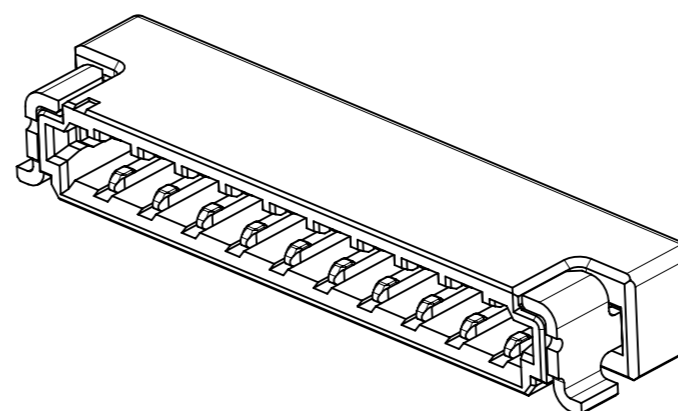
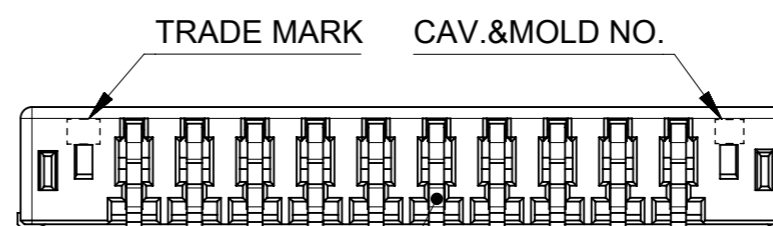
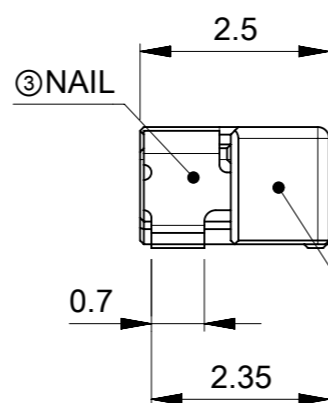
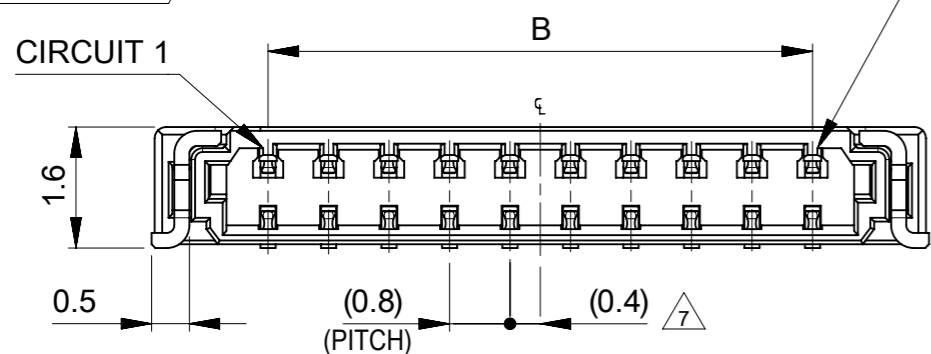
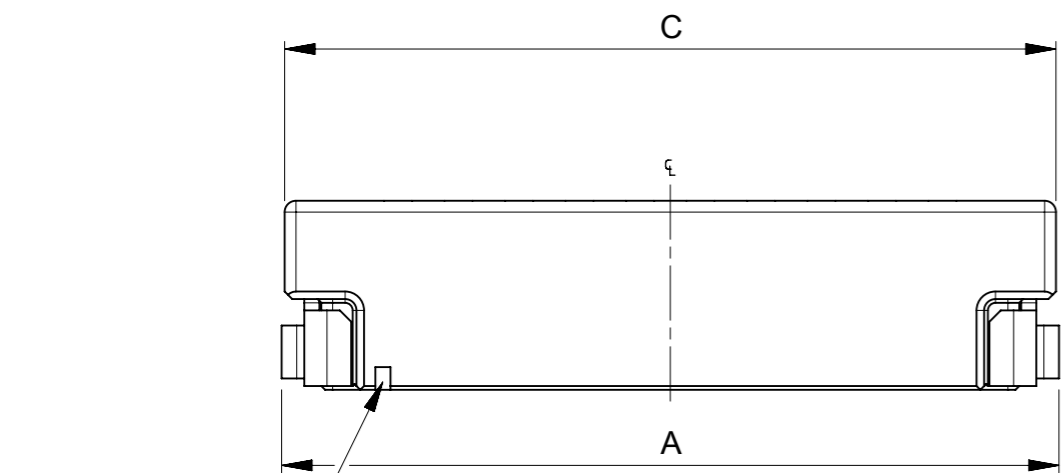

① TABLE 1

番号 NO.	部品 PART	材質 MATERIAL
①	ハウジング HOUSING	液晶ポリマー(LCP), UL94 V-0, LOW HALOGEN, 黒 LIQUID CRYSTAL POLYMER(LCP), UL94 V-0, LOW HALOGEN, BLACK
②	ターミナル TERMINAL	銅合金 COPPER ALLOY
		ニッケルめっき(下地) : 1.0 MICROMETER MINIMUM NICKEL (UNDER PLATING) 錫めっき(リフロー処理) : 1.0 MICROMETER MINIMUM MATTE TIN REFLOW TREATMENT
③	ネイル NAIL	リン青銅 PHOSPHOR BRONZE
		ニッケルめっき(下地) : 1.0 MICROMETER MINIMUM NICKEL (UNDER PLATING)
		錫めっき(リフロー処理) : 1.0 MICROMETER MINIMUM MATTE TIN REFLOW TREATMENT

E	D	C	B	A	極数 CIRCUIT SIZE
18.8		18.2	15.2	18.28	20
18.0		17.4	14.4	17.48	19
17.2		16.6	13.6	16.68	18
16.4		15.8	12.8	15.88	17
15.6		15	12	15.08	16
14.8		14.2	11.2	14.28	15
14.0	5.6	13.4	10.4	13.48	14
13.2		12.6	9.6	12.68	13
12.4		11.8	8.8	11.88	12
11.6		11	8	11.08	11
10.8		10.2	7.2	10.28	10
10.0		9.4	6.4	9.48	9
9.2		8.6	5.6	8.68	8
8.4		7.8	4.8	7.88	7
7.6	3.2	7	4	7.08	6
6.8		6.2	3.2	6.28	5
6.0	2.9	5.4	2.4	5.48	4
5.2	2.1	4.6	1.6	4.68	3
4.4	1.3	3.8	0.8	3.88	2

THIS DRAWING CONTAINS INFORMATION THAT IS PROPRIETARY TO MOLEX ELECTRONIC TECHNOLOGIES, LLC AND SHOULD NOT BE USED WITHOUT WRITTEN PERMISSION		CURRENT REV DESC:		molex	
DIMENSION UNITS	SCALE				
mm	NTS			ZERO-HACHI 0.8 HDR SINGLE ROW RA ASSY	
GENERAL TOLERANCES (UNLESS SPECIFIED)				PRODUCT CUSTOMER DRAWING	
ANGULAR TOL	± 3.0°			DOCUMENT NUMBER	
4 PLACES	± 0.2	EC NO: 693607		DOC TYPE	
3 PLACES	± 0.2	DRWN: HKOBAYASHI 2021/07/12		DOC PART	
2 PLACES	± 0.2	CHK'D: AIDA 2022/01/28		REVISION	
1 PLACE	± 0.2	APPR: SAKIYAMA 2022/01/28		2147210000-SD	
0 PLACES	± 0.2	INITIAL REVISION:		PSD 000 A	
DRAFT WHERE APPLICABLE MUST REMAIN WITHIN DIMENSIONS		THIRD ANGLE PROJECTION		MATERIAL NUMBER	
		DRAWING		CUSTOMER	
		A3-SIZE		GENERAL	
		SERIES		SHEET NUMBER	
		214721		1 OF 4	

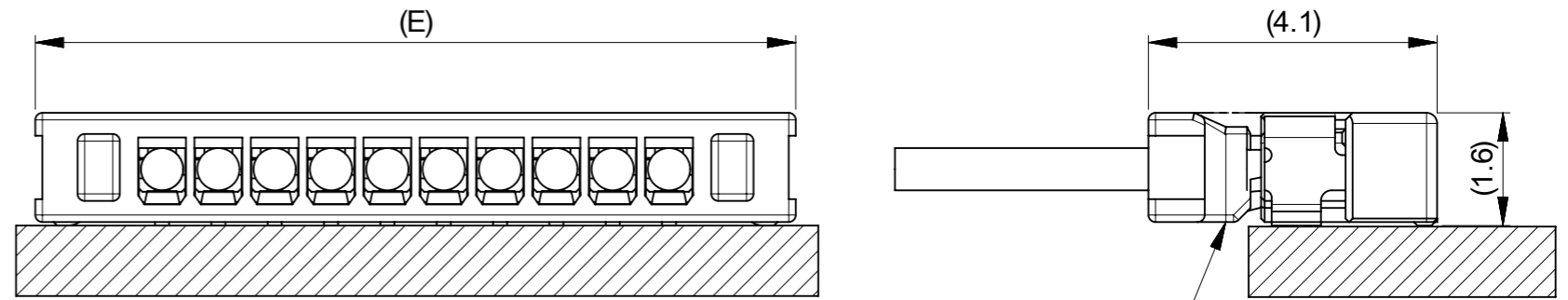
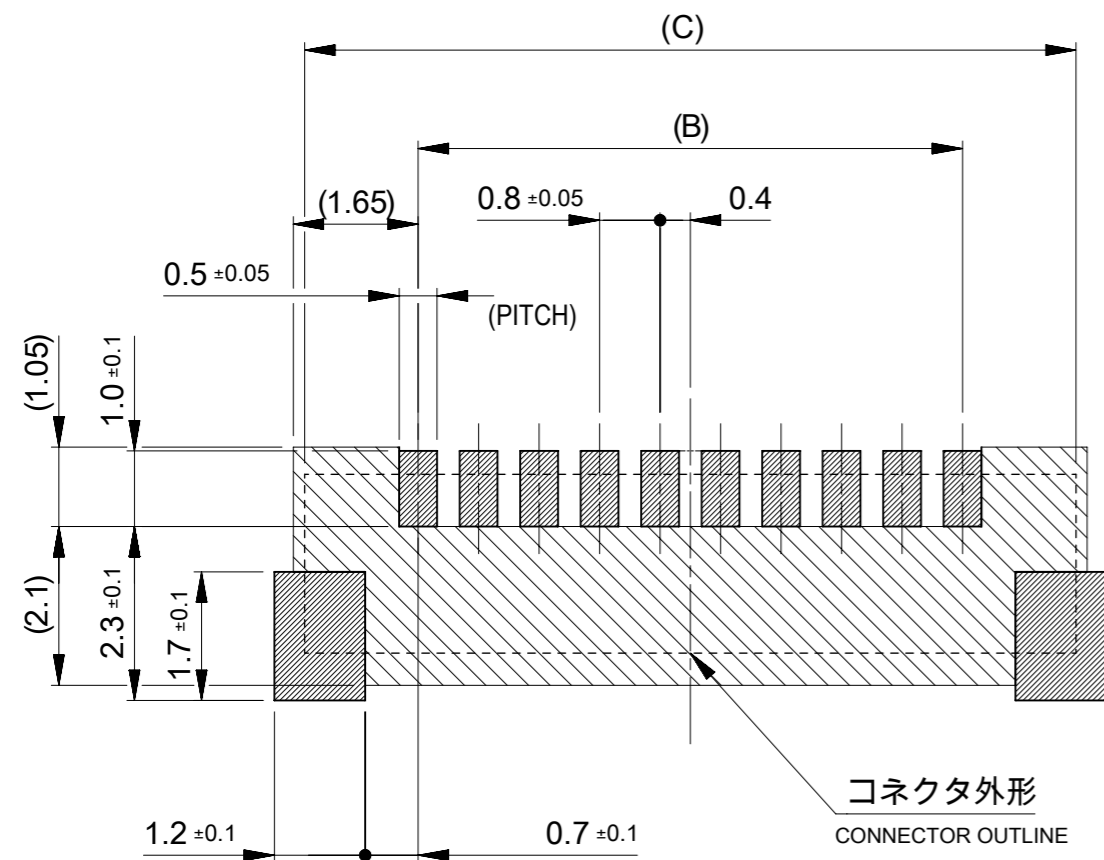

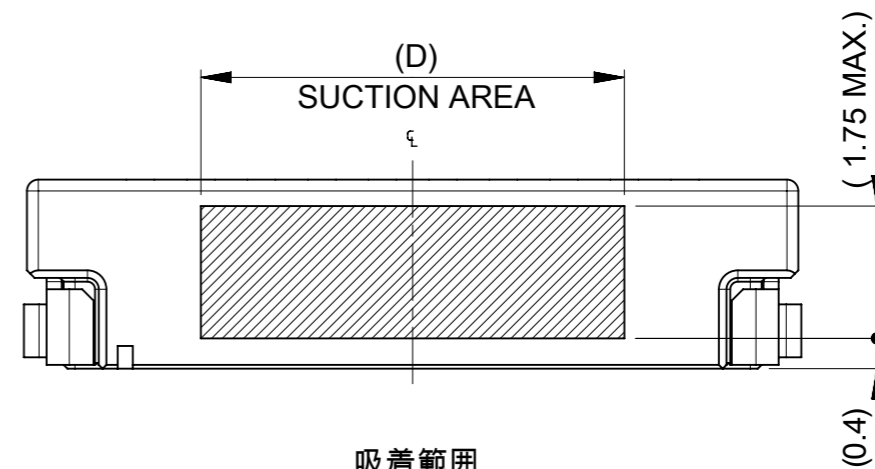

嵌合相手 : 214719シリーズ
MATE WITH:214719 SERIES

嵌合状態図
MATED CONNECTORS



吸着範囲
SUCTION AREA

 推奨基板パターンレイアウト(参考)
RECOMENDED PCB PATTERN LAYOUT(REF.)
(参考 : メタルマスク厚さ 0.1mm, マスク開口率100%)
(REF:METAL MASK THICKNESS 0.1mm, APERTURE RATIO 100%)

 パターン非推奨エリア
パターンを引き回す際は、製品機能に影響がないことをご確認ください。
PATTERN IS NOT RECOMMENDED ON THE HATCHING AREA
PLEASE CHECK NOT TO HAVE PROBLEM FOR PRODUCT FUNCTION
WHEN SETTING PATTERN ON THE HATCHING AREA.

THIS DRAWING CONTAINS INFORMATION THAT IS PROPRIETARY TO MOLEX ELECTRONIC TECHNOLOGIES, LLC AND SHOULD NOT BE USED WITHOUT WRITTEN PERMISSION									
DIMENSION UNITS		SCALE		CURRENT REV DESC:				molex	
mm		NTS							
GENERAL TOLERANCES (UNLESS SPECIFIED)				EC NO: 693607				ZERO-HACHI 0.8 HDR SINGLE ROW RAASSY	
ANGULAR TOL ± 3.0 °				DRWN: HKOBAYASHI 2021/07/12				PRODUCT CUSTOMER DRAWING	
4 PLACES ± 0.2				CHK'D: AIDA 2022/01/28				DOCUMENT NUMBER	
3 PLACES ± 0.2				APPR: SAKIYAMA 2022/01/28				2147210000-SD	
2 PLACES ± 0.2				INITIAL REVISION:				DOC TYPE	
1 PLACE ± 0.2				DRWN: HKOBAYASHI 2021/07/12				PSD	
0 PLACES ± 0.2				APPR: SAKIYAMA 2022/01/28				DOC PART	
DRAFT WHERE APPLICABLE MUST REMAIN WITHIN DIMENSIONS				THIRD ANGLE PROJECTION		DRAWING		REVISION	
				A3-SIZE		SERIES		A	
				214721		MATERIAL NUMBER		SHEET NUMBER	
				GENERAL		CUSTOMER		2 OF 4	

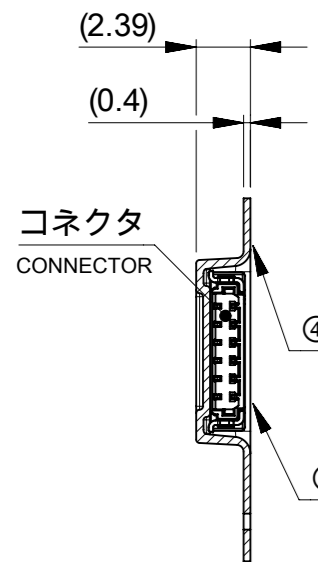
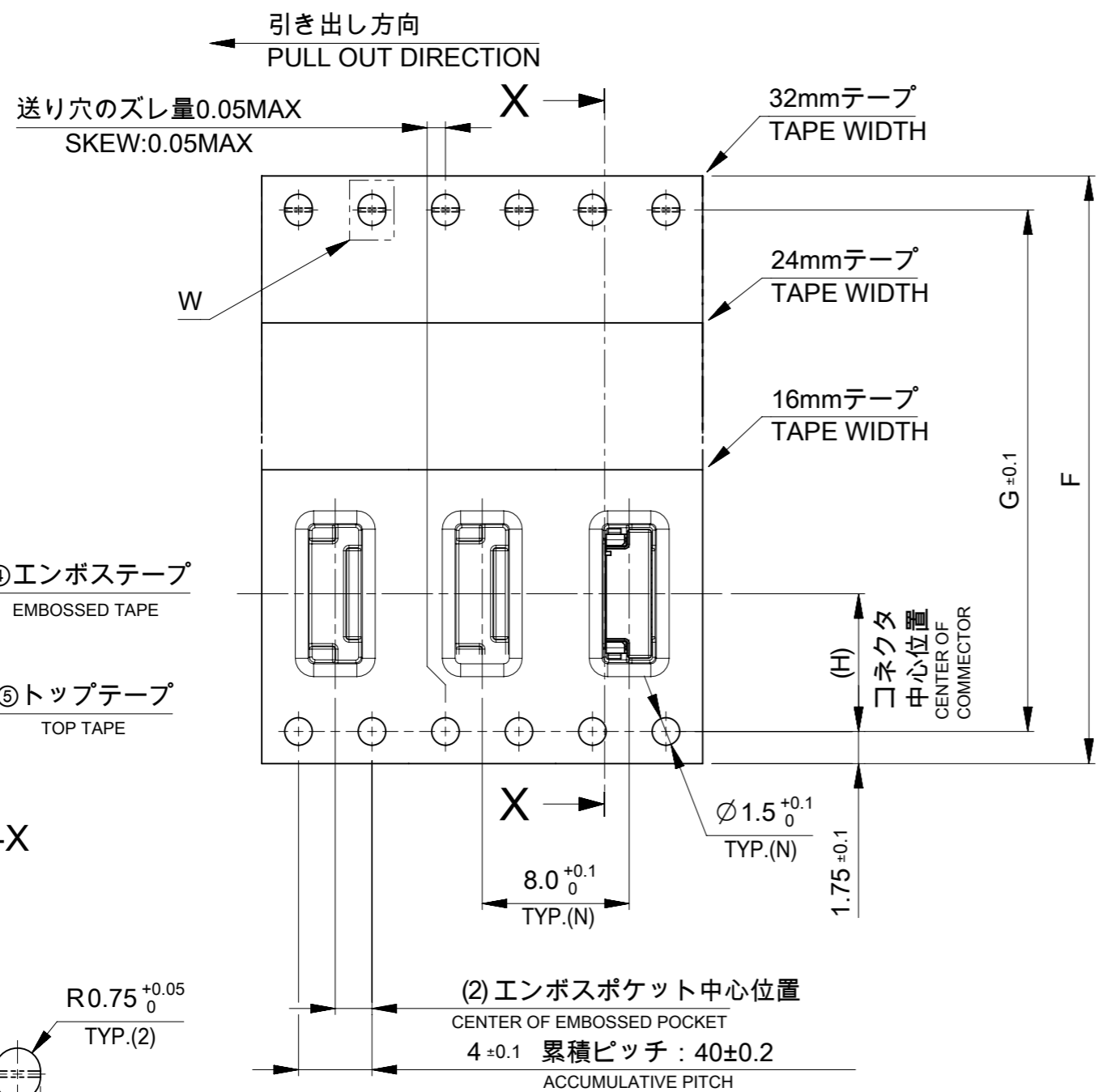

SECTION X-X

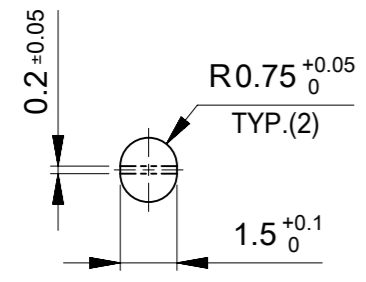

DETAIL W
SCALE 5:1

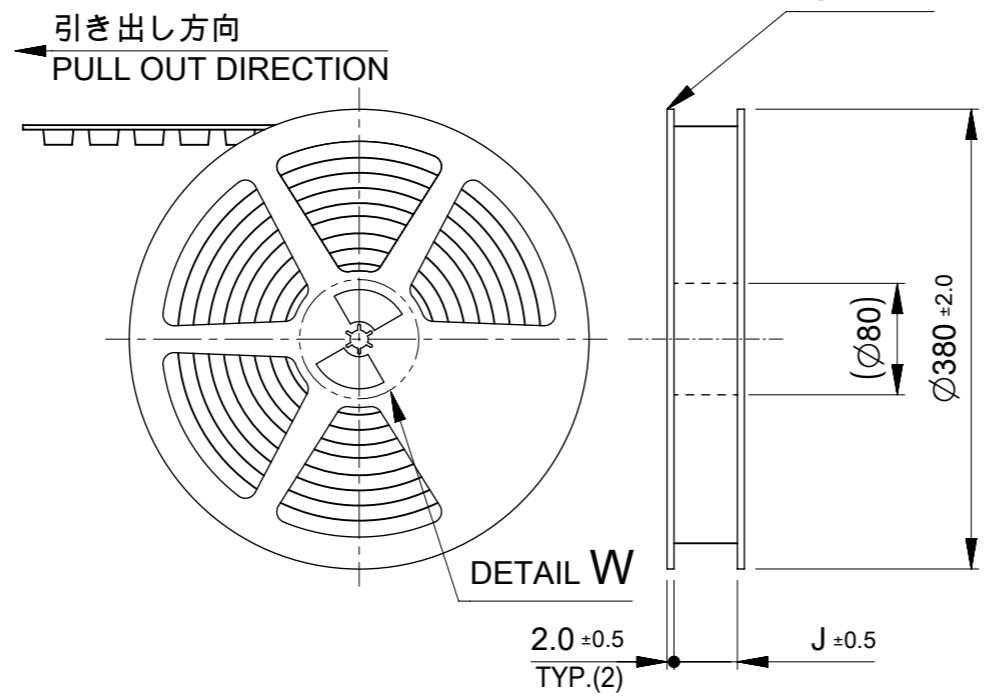

DETAIL W

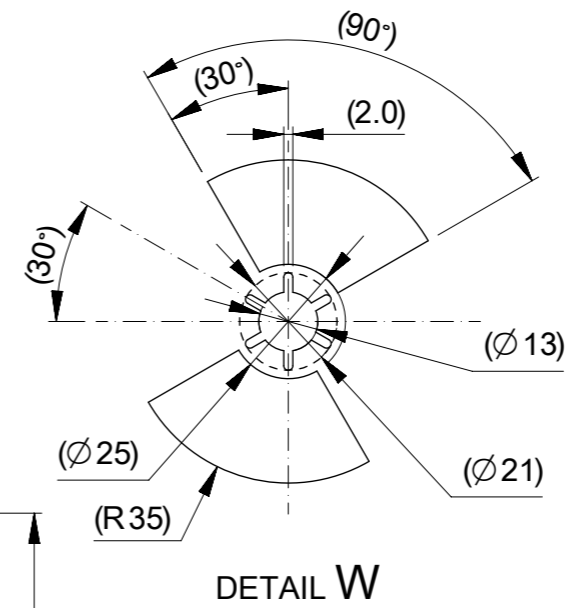

DETAIL W

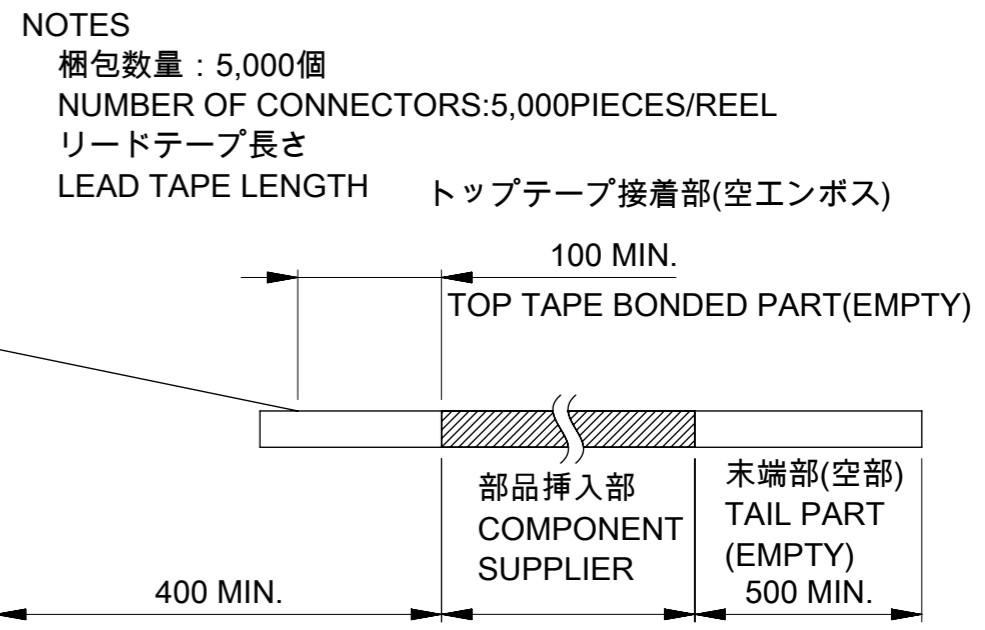

トップテープの剥離強度はIEC60286-3に準拠。
TOP TAPE PELING FORCE IS DEFINED BY IEC60286-3.
梱包仕様書: 2147219200-SPK PS 200
PACKAGING SPECIFICATION: 2147219200-SPK PS 200

33.5	14.2	28.4	32±0.3	20
				19
				18
				17
				16
				15
				14
				13
25.5	11.5	-	24+0.3/-0.1	12
				11
				10
				9
				8
				7
				6
				5
17.5	7.5	-	16+0.3/-0.1	4
				3
				2
J	H	G	エンボステープ幅F WIDTH OF TAP F	極数 CIRCUIT SIZE

番号 No.	部品 PART	材質 MATERIAL
④	エンボステープ EMBOSSED TAPE	ポリスチレン(PS) POLYSTYLENE(PS), etc
⑤	トップテープ TOP TAPE	ポリエチレン(PE),その他 POLYETHYLENE(PE), etc
⑥	リール REEL	ポリスチレン(PS) POLYSTYLENE

THIS DRAWING CONTAINS INFORMATION THAT IS PROPRIETARY TO MOLEX ELECTRONIC TECHNOLOGIES, LLC AND SHOULD NOT BE USED WITHOUT WRITTEN PERMISSION

DIMENSION UNITS	SCALE	CURRENT REV DESC:	molex		
mm	NTS				
GENERAL TOLERANCES (UNLESS SPECIFIED)			ZERO-HACHI 0.8 HDR SINGLE ROW RAASSY		
ANGULAR TOL	± 3.0 °	EC NO: 693607	PRODUCT CUSTOMER DRAWING		
4 PLACES	± 0.2	DRWN: HKOBAYASHI	DOCUMENT NUMBER		
3 PLACES	± 0.2	CHK'D: AIDA	DOC TYPE		
2 PLACES	± 0.2	APPR: SAKIYAMA	DOC PART		
1 PLACE	± 0.2	INITIAL REVISION:	REVISION		
0 PLACES	± 0.2	DRWN: HKOBAYASHI	2147210000-SD		
DRAFT WHERE APPLICABLE MUST REMAIN WITHIN DIMENSIONS			GENERAL		
THIRD ANGLE PROJECTION			SHEET NUMBER		
DRAWING			3 OF 4		
SERIES			A		
MATERIAL NUMBER			214721		
CUSTOMER			GENERAL		

半嵌合防止形状(11極 ~ 20極)

INCOMPLETE MATING PREVENTION SHAPE (11~20 CIRCUIT)

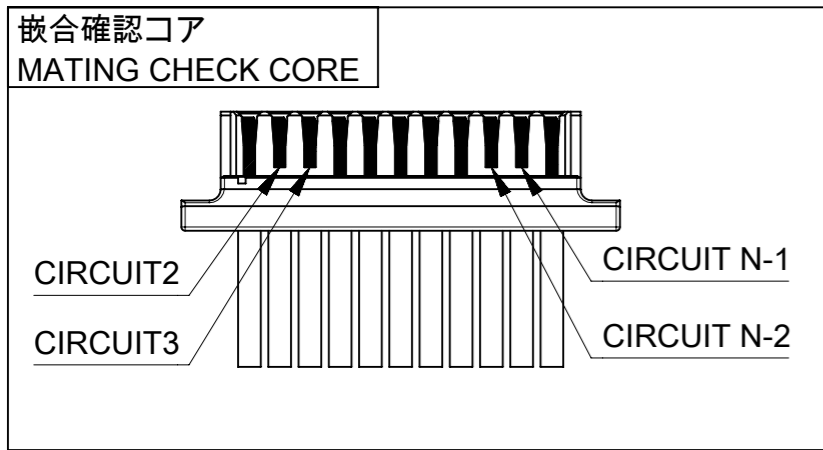

端子露出部
EXPOSED TERMINAL

半嵌合状態では嵌合確認コアの
圧着端子が露出しています

THE EXPOSED TERMINAL CONTACTS IN MATING CHECK CORE
INDICATES THE CRIMP HOUSING IS NOT COMPLETELY MATED TO THE HEADER.

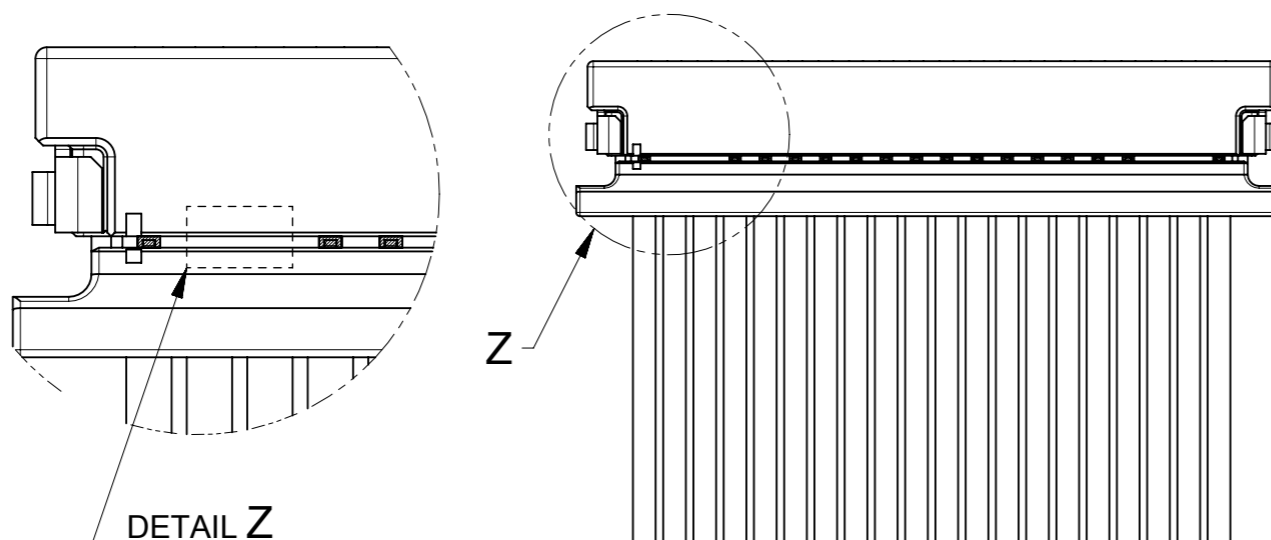
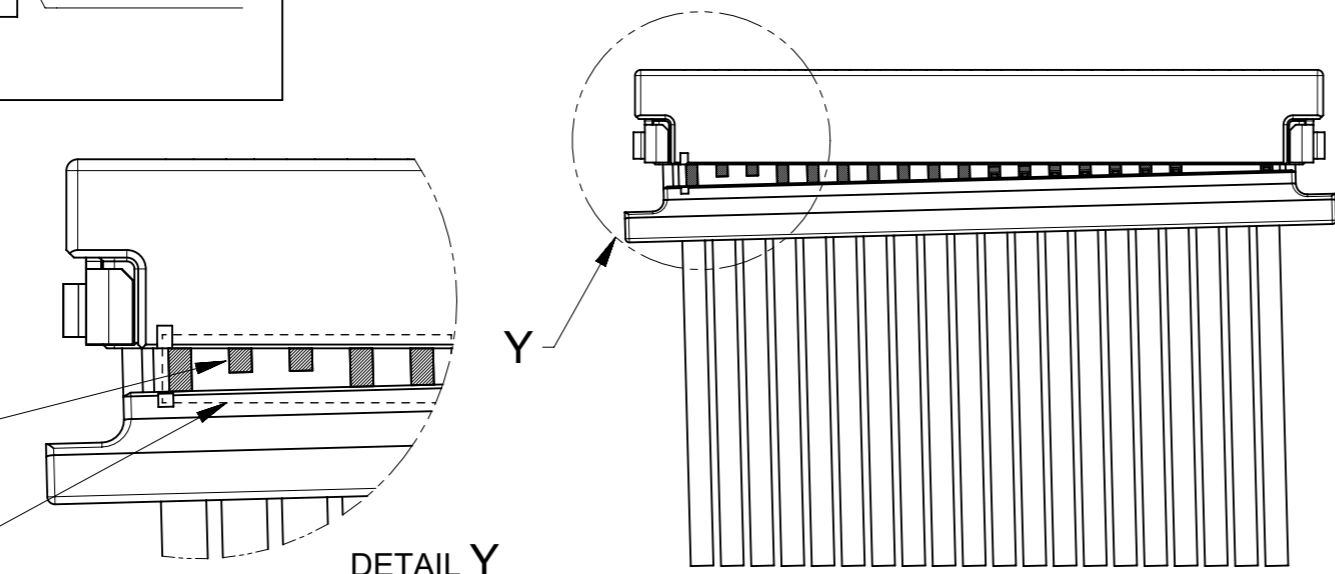

正しい位置まで嵌合すると嵌合確認コアの
圧着端子が隠れて目視出来なくなります。

WHEN THE TERMINAL CONTACTS IN MATING CHECK CORE ARE NOT EXPOSED,
IT INDICATES THE CRIMP HOUSING IS COMPLETELY MATED TO THE HEADER.

△ 8 発注番号一覧
ORDER NUMBER LIST

黒 BLACK	ハウジング色 HOUSING COLOR
214721 0200	20
214721 0190	19
214721 0180	18
214721 0170	17
214721 0160	16
214721 0150	15
214721 0140	14
214721 0130	13
214721 0120	12
214721 0110	11
214721 0100	10
214721 0090	9
214721 0080	8
214721 0070	7
214721 0060	6
214721 0050	5
214721 0040	4
214721 0030	3
214721 0020	2
発注番号 ORDER NO.	極数 CIRCUIT SIZE
梱包形態 : エンボスリール PACKAGE:EMBOSSED REEL	

THIS DRAWING CONTAINS INFORMATION THAT IS PROPRIETARY TO MOLEX ELECTRONIC TECHNOLOGIES, LLC AND SHOULD NOT BE USED WITHOUT WRITTEN PERMISSION

DIMENSION UNITS mm	SCALE NTS	CURRENT REV DESC:	molex		
GENERAL TOLERANCES (UNLESS SPECIFIED)	ANGULAR TOL ± 3.0°	EC NO: 693607			
4 PLACES ± 0.2	3 PLACES ± 0.2	DRWN: HKOBAYASHI	2021/07/12		
2 PLACES ± 0.2	1 PLACE ± 0.2	CHK'D: AIDA	2022/01/28		
0 PLACES ± 0.2		APPR: SAKIYAMA	2022/01/28		
DRAFT WHERE APPLICABLE MUST REMAIN WITHIN DIMENSIONS	THIRD ANGLE PROJECTION	DRAWING A3-SIZE	SERIES 214721	MATERIAL NUMBER 2147210000-SD	CUSTOMER GENERAL
				DOCUMENT NUMBER	DOC TYPE DOC PART REVISION
				2147210000-SD	PSD 000 A
					SHEET NUMBER 4 OF 4