

QLSP04PCAU
(3030 PC Amber)



Product Outline:

This is the high power LED with reflector type. EMC 3030 Single color is a surface-mount LED which with heat sink to enhance operating performance. With special binning technology, these LEDs are ideal for architecture lighting and special lighting needs.

Features:

- PC Amber color LED
- High brightness output @ 350mA,
- High driving current to 500mA.
- Package Dimension = 3.2mmX3.0mmX0.6mm
- RoHS compliant
- Custom Bin available upon special request
- View angel >110°

Application:

- Warning lamp
- Decoration lamp
- Architecture Lighting
- Garden Lighting

Compliance and Certification:



Mechanical Property: (Dimension)

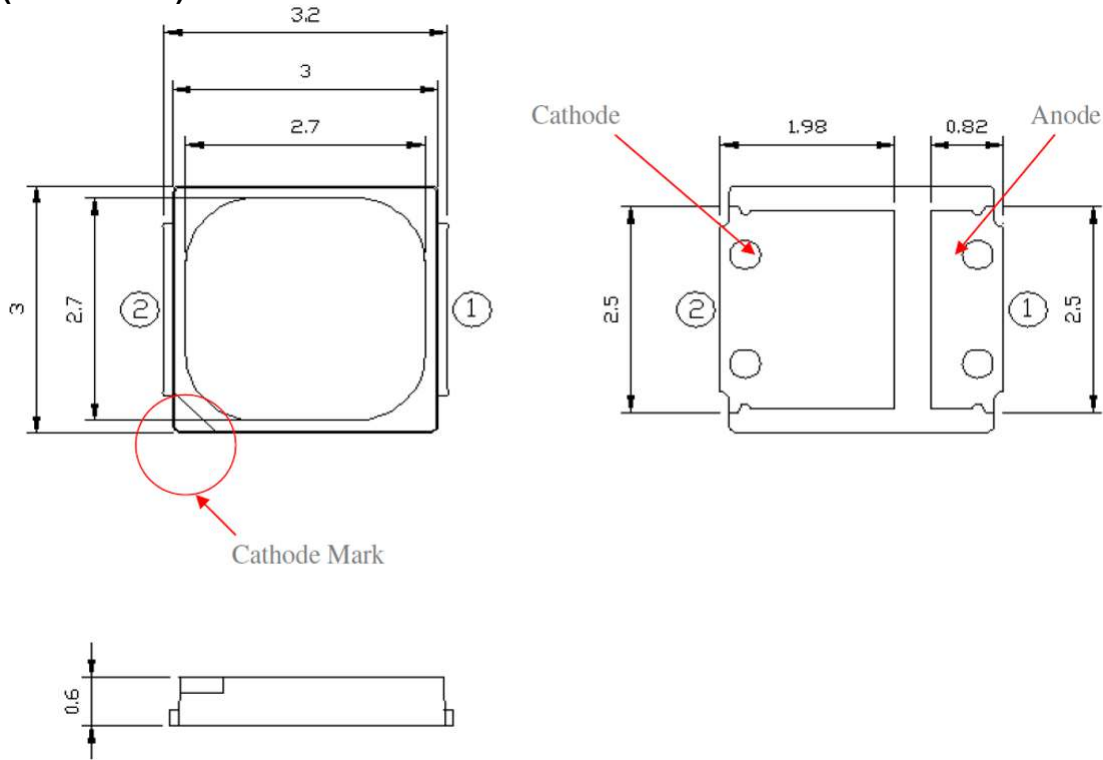

- * All dimensions are in millimeters,
- * Tolerances are $\pm 0.10\text{mm}$.

Recommended Solder footprint:

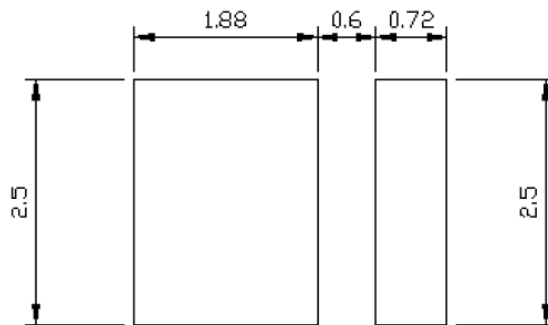

- * All dimensions are in millimeters.
- * The LEDs is designed to be reflow soldered on to a PCB. IF dip soldered that QL cannot guarantee its reliability.
- * Reflow soldering must not be performed more than twice.



Characteristics

■ Absolute Maximum Ratings

(Ta=25°C)

Parameter	Symbol	Rating	Unit
DC Forward Current	If	500	mA
Leakage Current	Ir	1.0	μA
Power Dissipation	Pd	1.7	W
Pulse Forward Current	Ifp	700	mA
LED Junction Temperature	TJ	125	°C
Storage Temperature	Tstg	-40 ~ 100	°C
Operation Temperature	Topr	-40 ~ 85	°C
Soldering Temperature	Tsol	260 < 10 sec	°C

- (1) Proper current rating must be observed to maintain junction temperature below maximum at all time
 (2) IFP Condition: Duty 1/10, Pulse within 10msec

■ Electrical / Optical Characteristic

(Ta=25 oC)

Parameter	Symbol	Condition	Min.	Typ.	Max.	Unit
Forward Voltage	Vf	350mA	3.0		3.5	V
View Angle	θ			120		deg
ESD Sensitivity(HBM)	KV			8.0		
Thermal Resistance	Rth			10		°C/W

- (1) Tolerance of measurement: VF=+/- 0.1V

■ Specification

Product	Color	Vf(V) IF=350mA	Dominant Wavelength(nm)	Luminous Flux IF=350mA	
				Min.	Typ.
QLSP04PCAU	PC Amber	3.2	588~595	110	118

*Tolerance = +/- 10%



■ **Groups**
CIE bin table

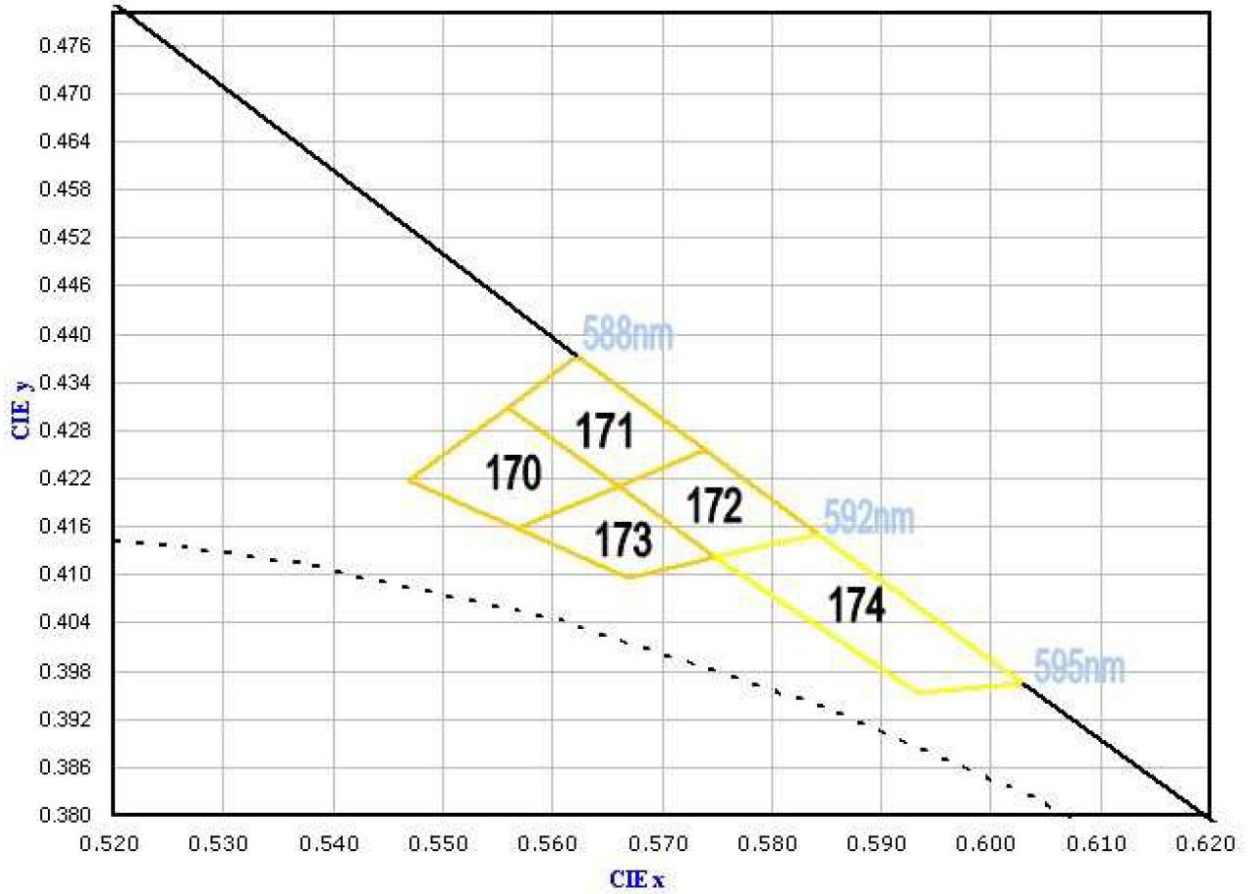

Color	Bin Code	P1_x	P1_y	P2_x	P2_y	P3_x	P3_y	P4_x	P4_y
PC Amber	170	0.5469	0.4218	0.5559	0.4309	0.566	0.4211	0.5568	0.4158
	171	0.5559	0.4309	0.5622	0.4372	0.5739	0.4255	0.566	0.4211
	172	0.566	0.4211	0.5739	0.4255	0.5843	0.4151	0.5748	0.4123
	173	0.5568	0.4158	0.566	0.4211	0.5748	0.4123	0.5669	0.4097
	174	0.5748	0.4123	0.5843	0.4151	0.6029	0.3965	0.5933	0.3952



Forward Voltage (V_F) Bin:

VF Rank @ 350mA			
Code name	Min.	Max.	Units
2	3	3.1	V
3	3.1	3.2	
4	3.2	3.3	
5	3.3	3.4	

The forward voltage tolerance is $\pm 0.1V$

Luminous Flux Bin:

lm Rank (lm) @ 350mA			
Code name	Min.	Max.	Units
QPE	110	118	lm
QPF	118	126	

Luminous flux tolerance is $\pm 7\%$



■ Characteristic Curves

(1) Color Spectrum

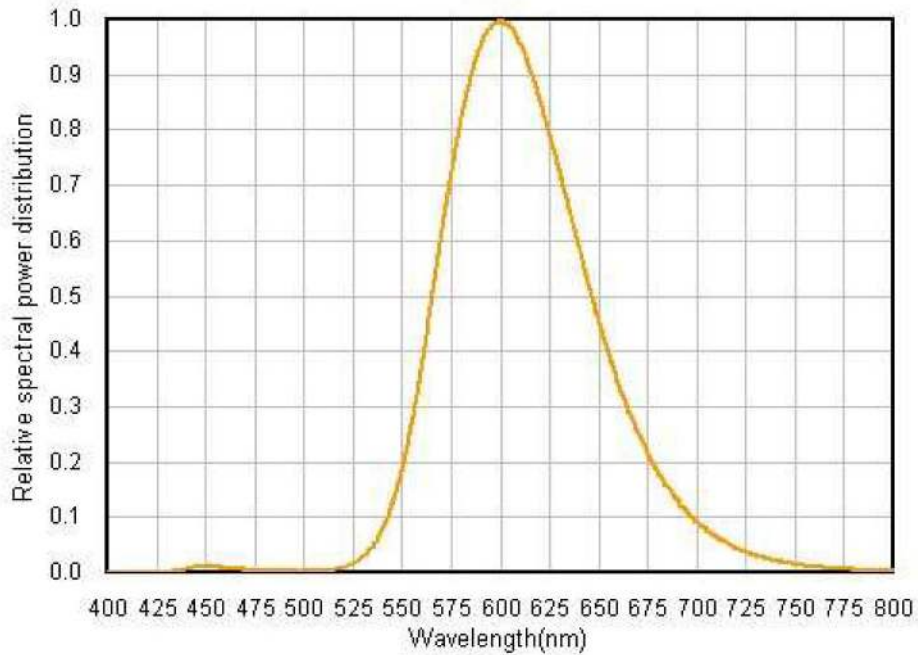

(2). Typical Representative Spatial Radiation Pattern

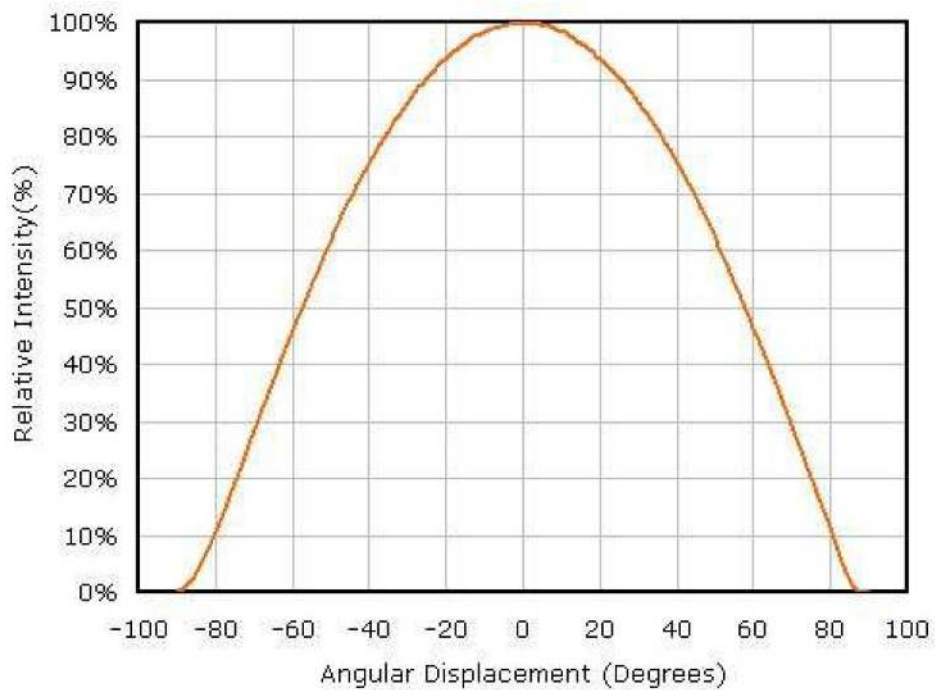

(3). Forward Current Characteristics

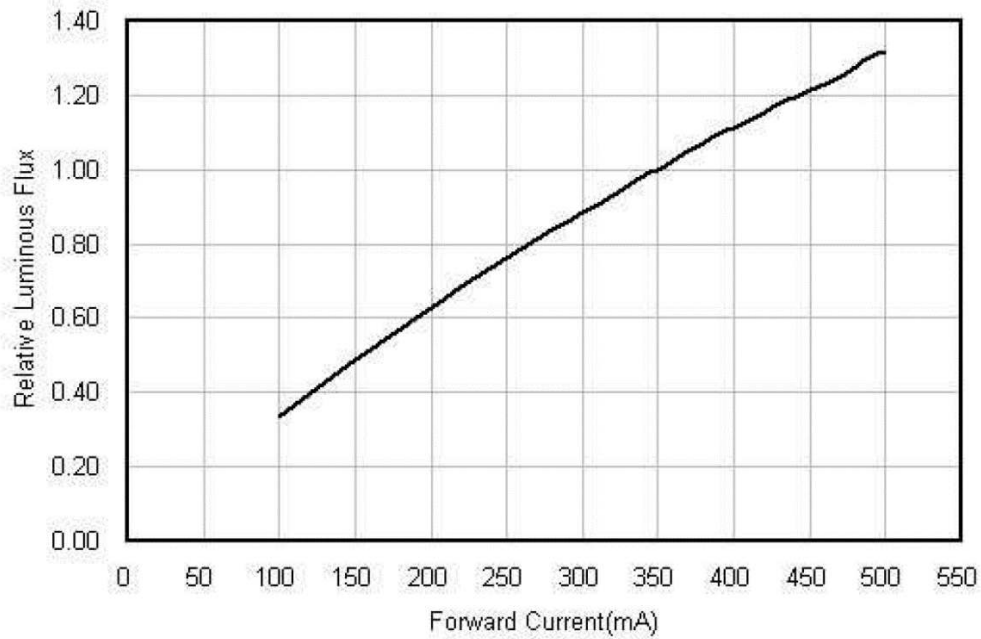

(4). Forward Current vs Forward Voltage

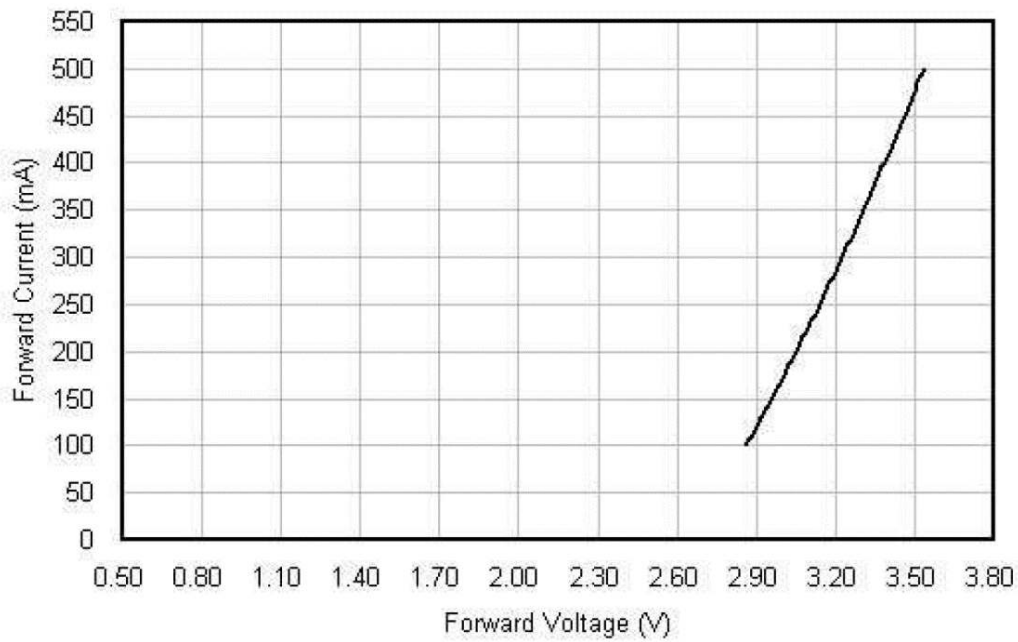

■ Reliability test:

No	Item	Condition	Time/Cycle	Sample size
1	Steady State Operating Life of Room Temperature	25°C Operating	1000 Hrs	20 pcs
2	Steady State Operating Life of Low Temperature -40°C	-40°C Operating	1000 Hrs	20 pcs
3	Steady State Operating Life of Low Temperature 60°C	60°C Operating	1000 Hrs	20 pcs
4	Steady State Operating Life of Low Temperature 85°C	85°C Operating	1000 Hrs	20 pcs
5	Low temperature storage -40°C	-40°C Storage	1000 Hrs	20 pcs
6	High temperature storage 100°C	100°C Storage	1000 Hrs	20 pcs
7	Steady State Operating Life of High Humidity Heat 60°C 90%	60°C/90% Operating	1000 Hrs	20 pcs
8	Steady State Pulse Operating Life Condition	25°C 10Hz duty=1/10 Operating	200 Cycle	20 pcs
9	Resistance to soldering heat on PCB (JEDEC MSL3)	pre-store@60°C, 60%RH for 52hrs T _{sld} max.=260 10sec	3 Times	20 pcs
10	Heat Cycle Test (JEDEC MRC)	25°C~65°C~-10°C, 90%RH, 24hr/1cycle	10 Cycle	20 pcs
11	Thermal shock	-40°C/ 20minr~ 5minr~100°C /20min	300 Cycle	20 pcs

■ Judgment Criteria:

Item	Symbol	Test Condition	Judgment Criteria
Forward Voltage	V _f	350 mA	ΔV _f < 10%
Luminous Flux	I _v	350 mA	ΔI _v < 30%



■ **Solder Profile:**

-The recommended reflow soldering profile is as follows (temperatures indicated are as measured on the surface of the LED resin):

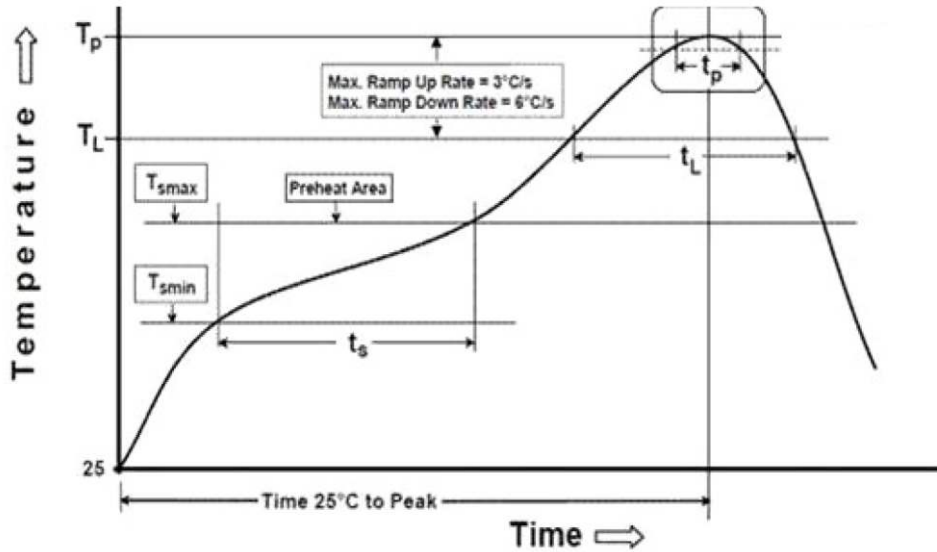

Profile Feature	Sn-Pb Eutectic Assembly	Pb-Free Assembly
Temperature Min(T_{smin})	100°C	150°C
Temperature Max(T_{smax})	150°C	200°C
Time(t_a) from (T_{smin} to T_{smax})	60-120 seconds	60-120 seconds
Ramp-up rate(T_L to T_p)	3°C/second max.	3°C/second max.
Liquidous Temperature(T_L)	183°C	217°C
Time(t_L) maintained above T_L	60-150 seconds	60-150 seconds
Peak package body temperature(T_p)	235°C	260°C
Time within 5°C of Actual Peak temperature (t_p)	20seconds*	30 seconds*
Ramp-down rate(T_p to T_L)	6°C/second max.	6°C/second max.
Time 25°C to peak temperature	6 minutes max.	8 minutes max.
* Tolerance for peak profile temperature (T_p) is defined as a supplier minimum and a user maximum.		



■ **Taping & Packing:**

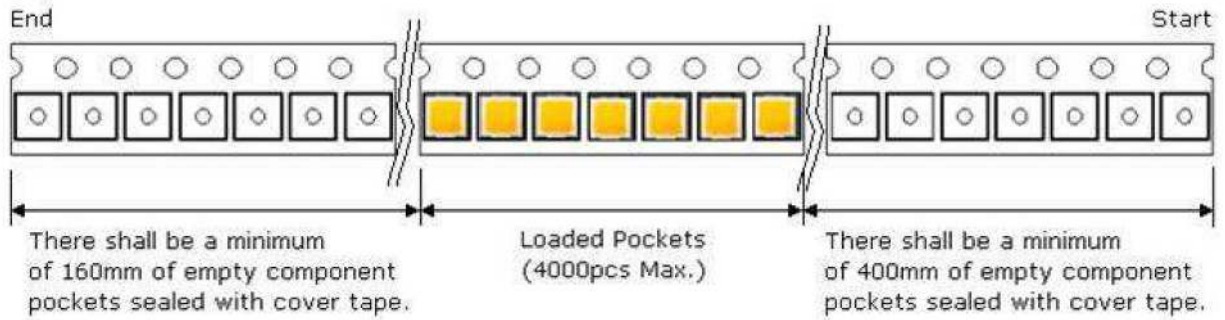
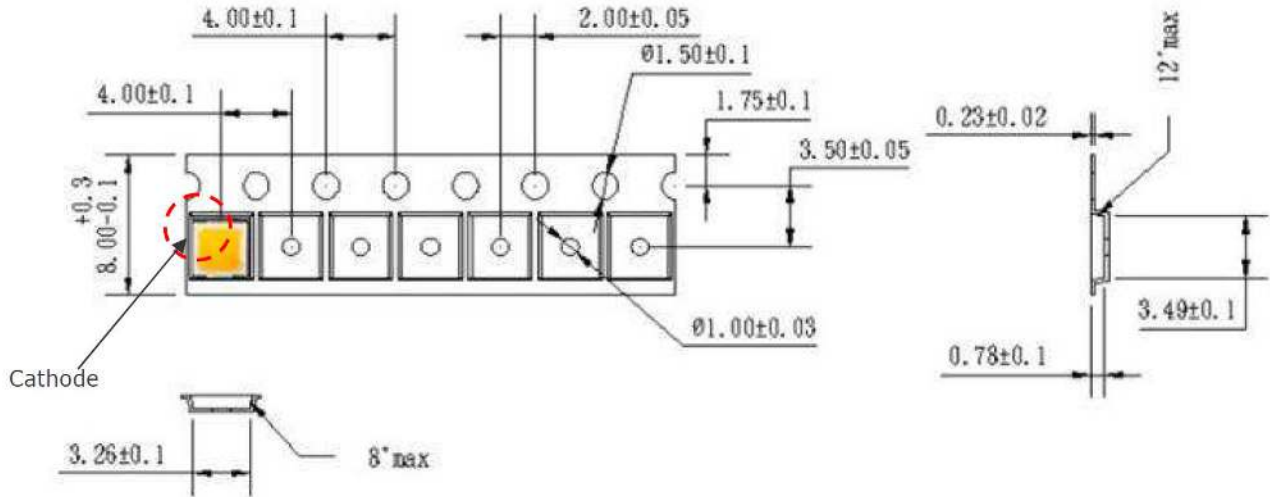

Unit : mm



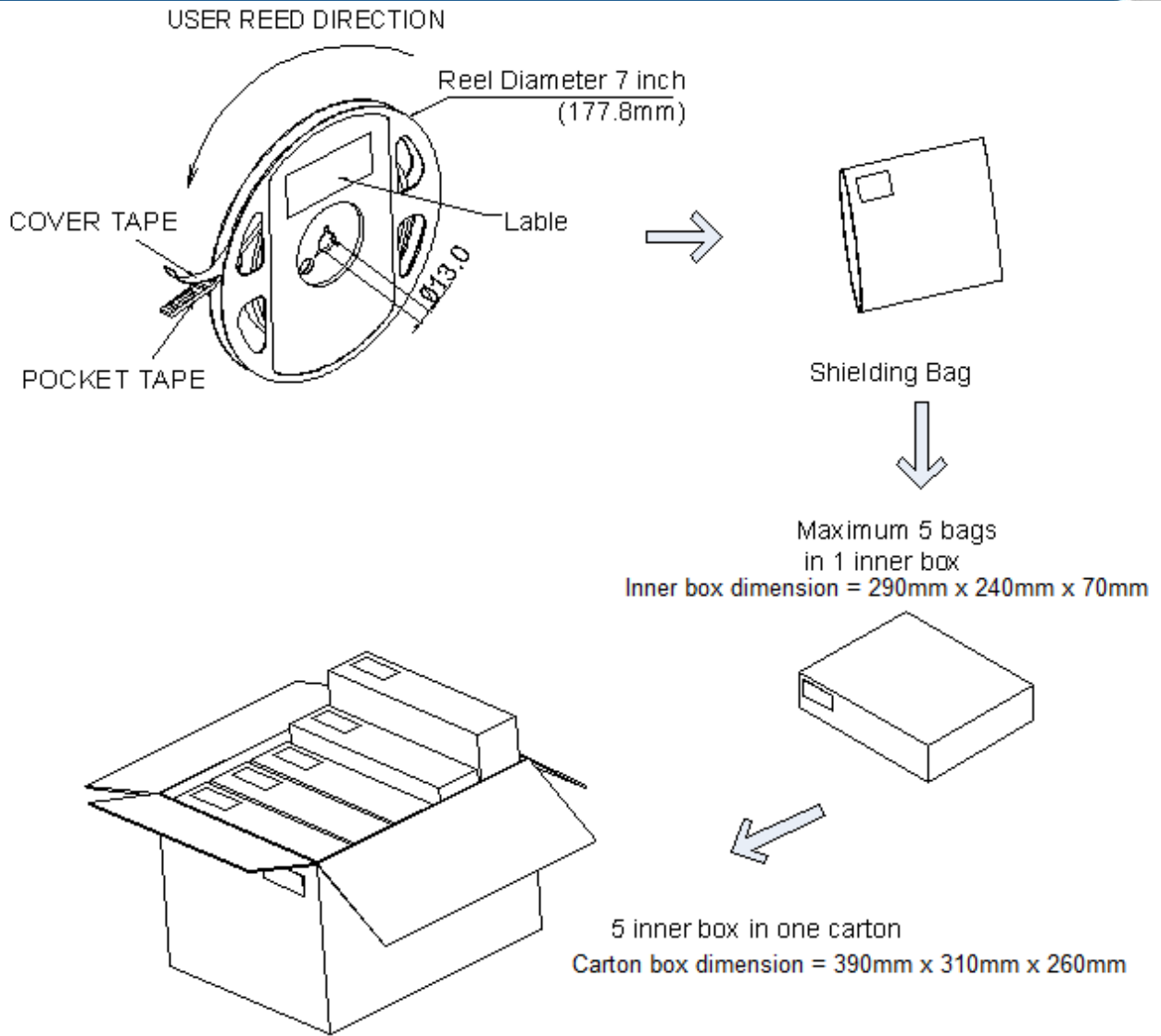

■ Labeling

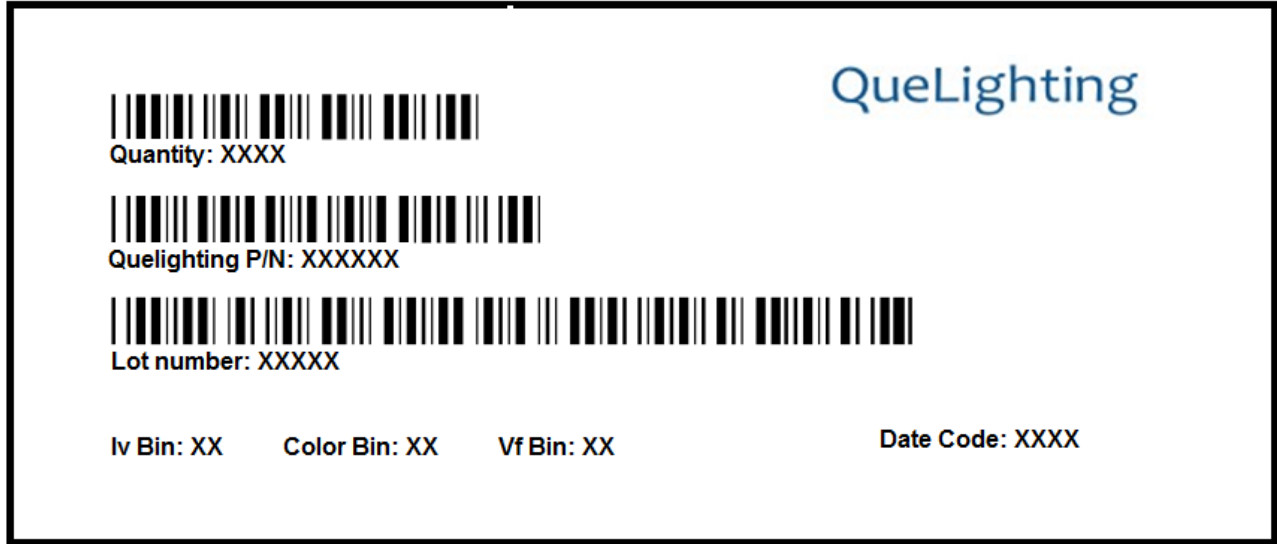

■ Ordering Information:

Part #	Multiple Quantities	Quantity per Reel
QLSP04PCAU-XXX		1000,2000 pcs



■ Revision History:

Revision Date:	Changes:	Version #:
09-02-2015	Initial release	1.0
09-15-2016	Update the performance	1.1
08-01-2018	Update the performance	1.2
09-22-2020	Upgrade the performance	2.0

