

# Thermal Monitor

## FEATURES

- On-Chip Temperature Transducer
- Temperature Comparator Gives Threshold Temperature Alarm
- Power Reference Permits Airflow Diagnostics
- Precision 2.5V Power Reference Permits Airflow Diagnostics
- Transducer Output is Easily Scaled for Increased Sensitivity
- Low 2.5mA Quiescent Current

## DESCRIPTION

The UC1730 family of integrated circuit devices are designed to be used in a number of thermal monitoring applications. Each IC combines a temperature transducer, precision reference, and temperature comparator allowing the device to respond with a logic output if temperatures exceed a user programmed level. The reference on these devices is capable of supplying in excess of 250mA of output current – by setting a level of power dissipation the rise in die temperature will vary with airflow past the package, allowing the IC to respond to airflow conditions

These devices come in an 8-Pin DIP, plastic or ceramic, a 5-Pin TO-220 or a PLCC-20 version. In the 8-Pin version, a PTAT (proportional to absolute temperature) output reports die temperature directly. This output is configured such that its output level can be easily scaled up with two external gain resistors. A second PTAT source is internally referenced to the temperature comparator. The other input to this comparator can then be externally programmed to set a temperature threshold. When this temperature threshold is exceeded an alarm delay output is activated. Following the activation of the delay output, a separate open collector output is turned on. The delay pin can be programmed with an external RC to provide a time separation between activation of the delay pin and the alarm pin, permitting shutdown diagnostics in applications where the open collector outputs of multiple parts are wire OR'ed together.

The 5-Pin version in the TO-220 package is well suited for monitoring heatsink temperatures. Enhanced airflow sensitivities can be obtained with this package by mounting the device to a small heatsink in the airstream. This version of the device does not include the PTAT output or the open collector alarm output.

## BLOCK DIAGRAM

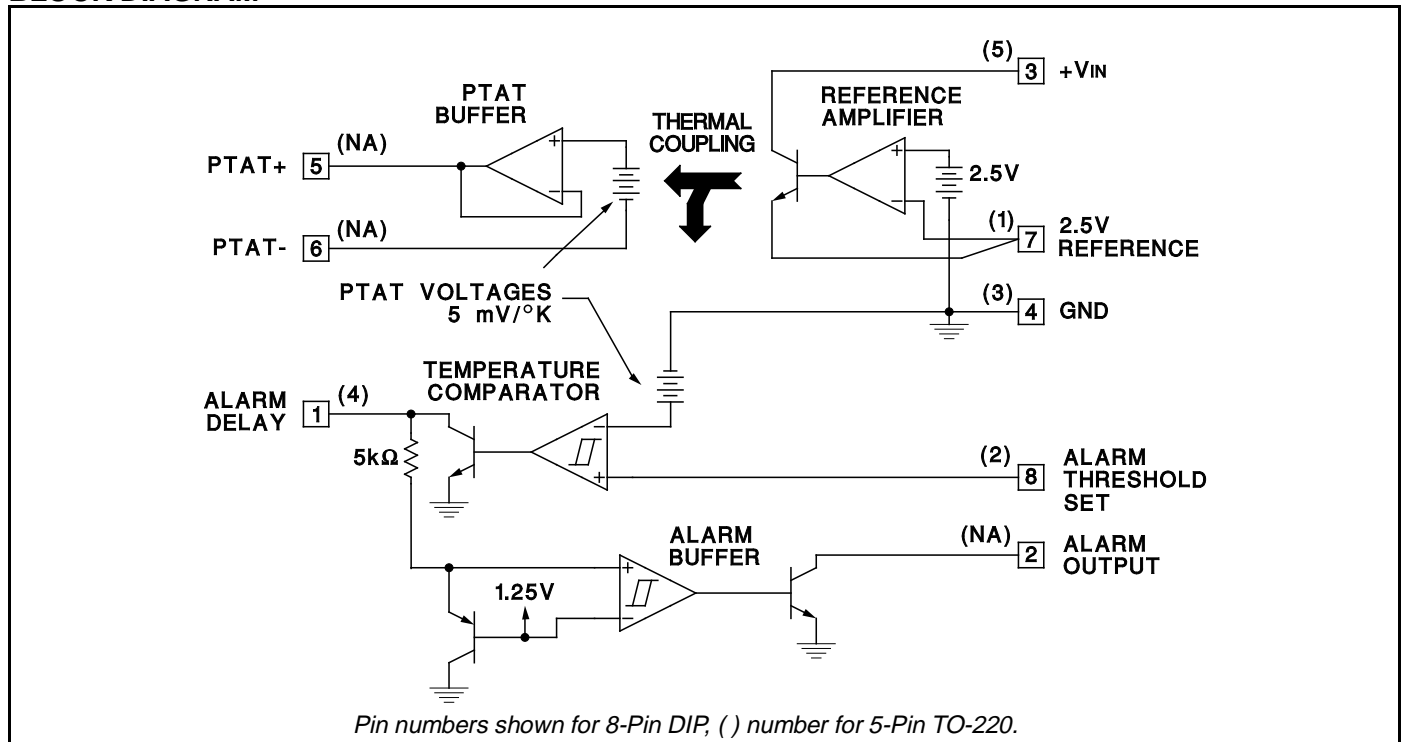

**ABSOLUTE MAXIMUM RATINGS**

Input Supply Voltage, (+VIN)	40V
Alarm Output Voltage (8-Pin Version Only)	40V
Alarm Delay Voltage	10V
Alarm Threshold Set Voltage	10V
2.5V Reference Output Current	-400 mA
Alarm Output Current (8-Pin Version Only)	0 mA
Power Dissipation at TA = 25°C (Note 2)	1000 mW
Power Dissipation at Tc = 25°C (Note 2)	2000 mW
Thermal Resistance Junction to Ambient	
N, 8-Pin Plastic DIP	110°C/W
J, 8-Pin Ceramic DIP	110°C/W

T, 5-Pin Plastic DIP TO-220	65°C/W
Thermal Resistance Junction to Case	
N, 8-Pin Plastic DIP	60°C/W
J, 8-Pin Ceramic DIP	40°C/W
T, 5-Pin Plastic TO-220	5°C/W
Operating Junction Temperature	-55°C to +150°C
Storage Temperature	-65°C to +150°C
Lead Temperature (Soldering, 10 Seconds)	300°C

*Note 1: Voltages are referenced to ground. Currents are positive into, negative out of, the specified terminals.*

*Note 2: Consult Packaging section of Databook for thermal limitations and considerations of package.*

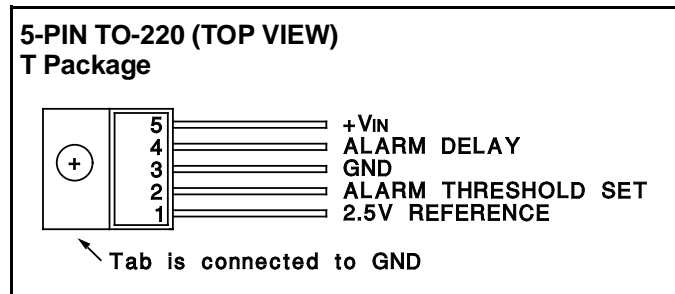
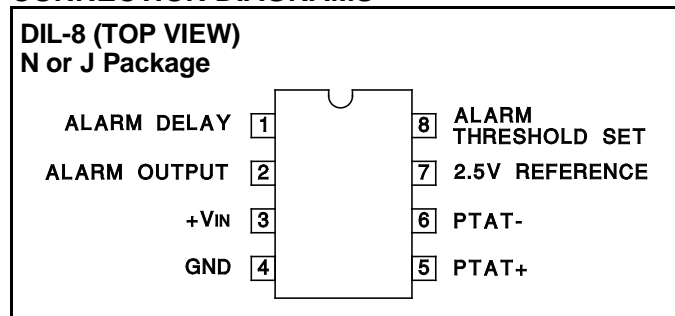
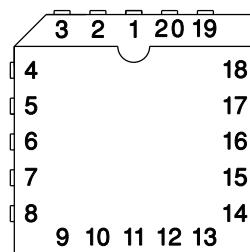
**CONNECTION DIAGRAMS****PLCC-20 (TOP VIEW)**  
Q Package

PACKAGE PIN FUNCTION	
FUNCTION	PIN
N/C	1-3
ALARM DELAY	4
ALARM OUTPUT	5
+VIN	6
GND	7
N/C	8-13
PTAT+	14
PTAT-	15
2.5V REFERENCE	16
2.5V REFERENCE	17
ALARM THRESHOLD SET	18
N/C	19-20

**ELECTRICAL CHARACTERISTICS:** Unless otherwise stated, these specifications apply for TJ = 0°C to +100°C for the UC3730, -25°C to +100°C for the UC2730 and -55°C to +125°C for the UC1730, +VIN = +5V, and PTAT- = 0V. TA = TJ.

PARAMETERS	TEST CONDITIONS	MIN	TYP	MAX	UNITS
<b>INPUT SUPPLY</b>					
Supply Current	+VIN = 35V		2.8	4.0	mA
	+VIN = 5V		2.3	3.5	mA
<b>REFERENCE</b>					
Output Voltage	TJ = 25°C	2.475	2.5	2.525	V
	Over Temperature	2.46		2.54	V
Load Regulation	IOUT = 0 to 250mA		8.0	25	mV
Line Regulation	+VIN = 5 to 25V		1.0	5.0	mV
<b>TEMPERATURE COMPARATOR</b>					
Temperature Comparator Threshold	at 300°K (26.85°C), Nominally 5mV/°K, VINUT High to Low	1.475	1.50	1.525	V
Temperature Error		-10		10	°C
Threshold Line Regulation	+VIN = 5 to 25V		0.005	0.02	%/V
Temperature Linearity	Note 2		2.0	5.0	°C
Threshold Hysteresis		3.0	8.0	15	mV
Input Bias Current	VINPUT at 1.5V	-0.5	-0.1		µA
Max Output Current	VOUT = 1V	1.2	3.0		mA
Output Sat Voltage	IOUT = 100µA		0.05	0.25	V

**ELECTRICAL CHARACTERISTICS (cont):**

Unless otherwise stated, these specifications apply for  $T_J = 0^\circ\text{C}$  to  $+100^\circ\text{C}$  for the UC3730,  $-25^\circ\text{C}$  to  $+100^\circ\text{C}$  for the UC2730 and  $-55^\circ\text{C}$  to  $+125^\circ\text{C}$  for the UC1730,  $+V_{IN} = +5\text{V}$ , and  $PTAT- = 0\text{V}$ .  $T_A = T_J$ .

PARAMETERS	TEST CONDITIONS	MIN	TYP	MAX	UNIT
<b>TEMPERATURE COMPARATOR (cont.)</b>					
Output Leakage Current	$V_{OUT} = 1\text{V}$		0.01	1.0	$\mu\text{A}$
<b>PTAT BUFFER (8-Pin N, or J Version Only)</b>					
Output Voltage	at $300^\circ\text{K}$ ( $26.85^\circ\text{C}$ ), Nominally $5\text{mV}/^\circ\text{K}$	1.460	1.50	1.54	V
	In 10X Config. + $V_{IN} = 25\text{V}$	14.6	15	15.4	V
Temperature Error		-12		12	$^\circ\text{C}$
Temperature Linearity (Note 2)			2.0	5.0	$^\circ\text{C}$
Line Regulation	$+V_{IN} = 5$ to $25\text{V}$		0.02	0.04	$\%/V$
Load Regulation	$I_{OUT} = 0$ to $2\text{mA}$		1.0	3.0	mV
Dropout Voltage	$PTAT + TO + V_{IN}$		1.9	2.5	V
Input Bias Current at $PTAT-$ Input		-3.0	-1.0		$\mu\text{A}$
<b>ALARM BUFFER COMPARATOR (8-Pin N, or J Version Only)</b>					
Threshold Voltage ( $V_{TH}$ )	Alarm Delay Input Low to High	1.1	1.2	1.3	V
Threshold Hysteresis Voltage	Alarm Delay Voltage $> V_{TH}$		100	250	mV
Input Bias Current	Alarm Delay Voltage $< V_{TH}$		0.1	0.5	$\mu\text{A}$
Max Output Current	$V_{OUT} = 1\text{V}$	7.0	15		mA
Output Sat Voltage	$I_{OUT} = 3\text{mA}$		0.25	0.45	V
Output Leakage	$V_{OUT} = 35\text{V}$		0.1	2.0	$\mu\text{A}$

Note 2: This parameter is guaranteed by design and is not tested in production.

**APPLICATIONS AND OPERATION INFORMATION**

**Scaling the PTAT Output (8 Pin Version Only)**

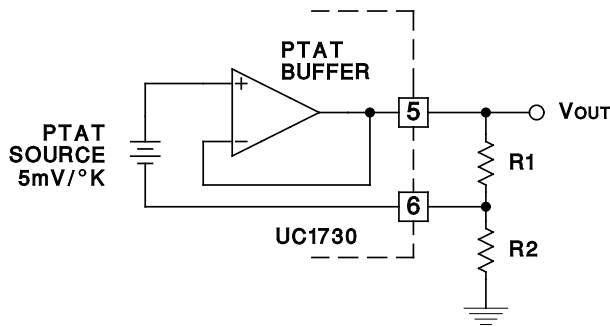

$$V_{OUT} = 5 \times \left(1 + \frac{R2}{R1}\right) \text{mV}/^\circ\text{K}$$

(Recommended Range for R1 is 2k to 4k)

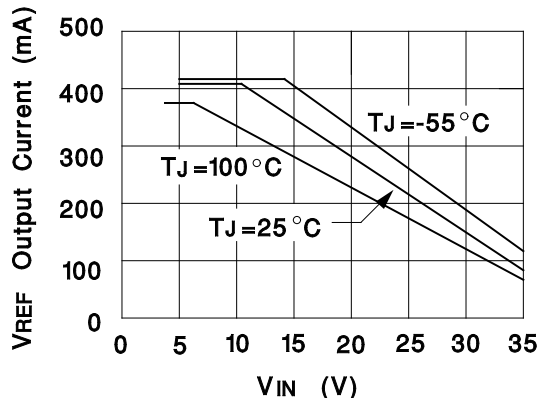

VREF Maximum Output Current vs Input Supply

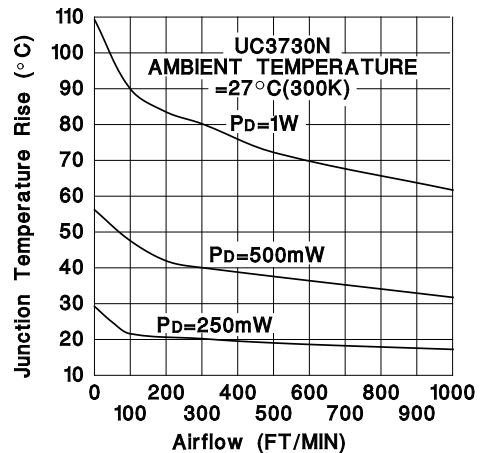

Junction Temperature Rise vs Airflow UC3730N (8-Pin Plastic Dip)

APPLICATIONS AND OPERATION INFORMATION (Cont.)

Setting a Temperature Threshold

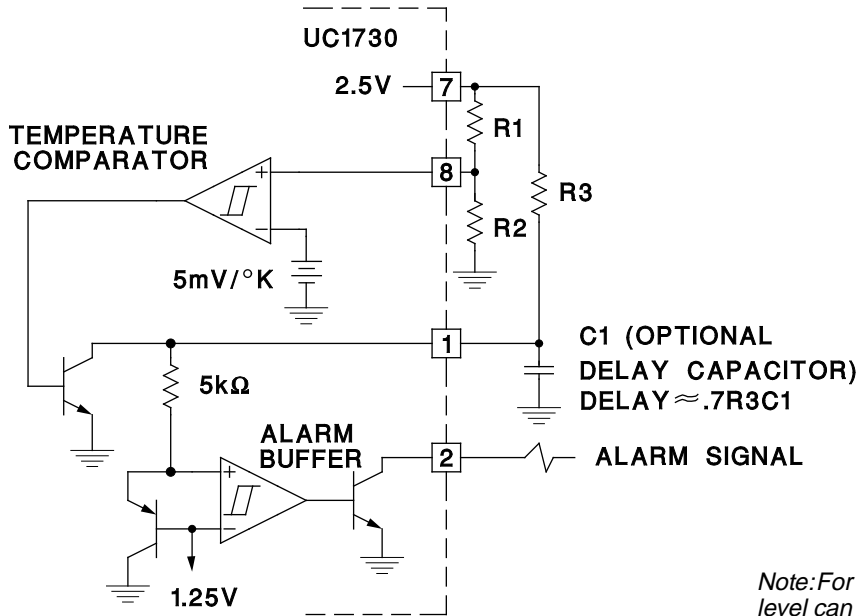

$$\text{Temperature Threshold } (^{\circ}\text{C}) = \left( \frac{2.5\text{V}}{0.005} \right) \times \frac{R2}{R1+R2} - 273.15$$

C1 (OPTIONAL DELAY CAPACITOR)  
DELAY  $\approx .7R3C1$

Note: For airflow monitoring a power dissipation level can be set with a resistive load,  $R_L$ , on the reference output.  $PD = (+V_{IN} - 2.5V)^2 / R_L$ .

Dual Speed Fan Control

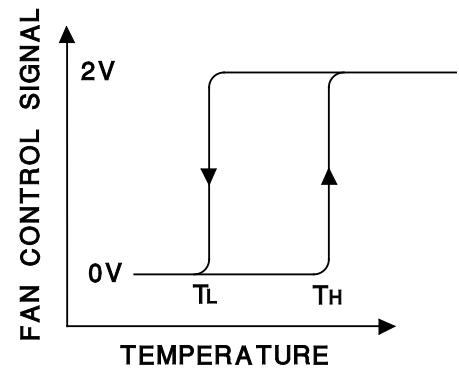
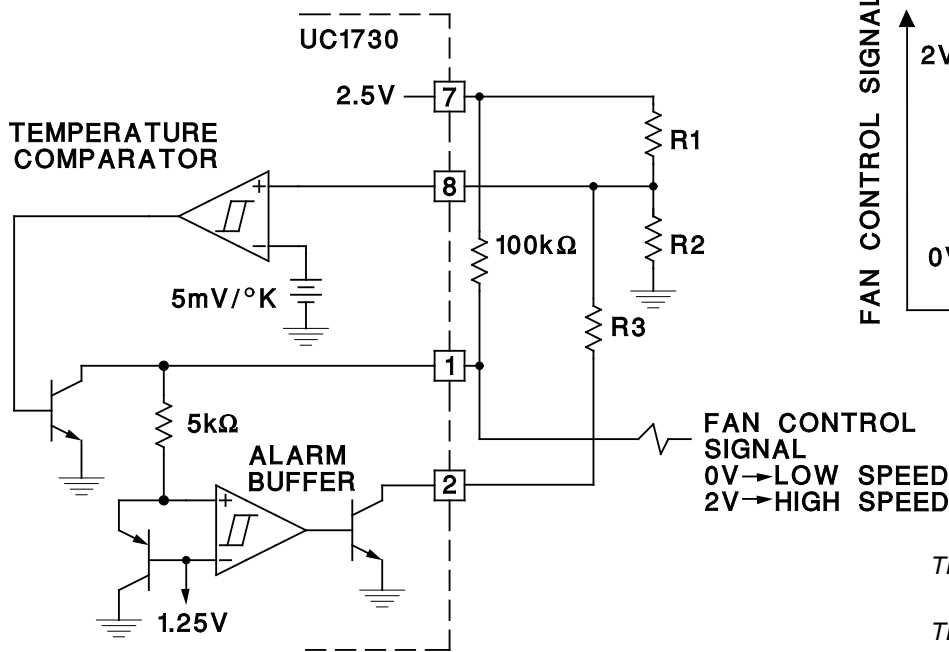

FAN CONTROL SIGNAL  
0V → LOW SPEED  
2V → HIGH SPEED

$$TH(^{\circ}\text{C}) = \frac{2.5\text{V}}{0.005} \times \frac{R2}{R1+R2} - 273.15$$

$$TL(^{\circ}\text{C}) = \frac{2.5\text{V}}{0.005} \times \frac{R_X}{R1+R_X} - 273.15$$

$$\text{Where: } R_X = R2 \times \frac{R3}{R2 + R3}$$

**PACKAGING INFORMATION**

Orderable Device	Status <sup>(1)</sup>	Package Type	Package Drawing	Pins	Package Qty	Eco Plan <sup>(2)</sup>	Lead/Ball Finish	MSL Peak Temp <sup>(3)</sup>
UC2730N	OBSOLETE	PDIP	P	8		TBD	Call TI	Call TI
UC2730T	OBSOLETE	TO-220	KC	5		TBD	Call TI	Call TI
UC3730N	OBSOLETE	PDIP	P	8		TBD	Call TI	Call TI
UC3730Q	OBSOLETE	PLCC	FN	20		TBD	Call TI	Call TI
UC3730QTR	OBSOLETE	PLCC	FN	20		TBD	Call TI	Call TI
UC3730T	OBSOLETE	TO-220	KC	5		TBD	Call TI	Call TI

<sup>(1)</sup> The marketing status values are defined as follows:

**ACTIVE:** Product device recommended for new designs.

**LIFEBUY:** TI has announced that the device will be discontinued, and a lifetime-buy period is in effect.

**NRND:** Not recommended for new designs. Device is in production to support existing customers, but TI does not recommend using this part in a new design.

**PREVIEW:** Device has been announced but is not in production. Samples may or may not be available.

**OBSOLETE:** TI has discontinued the production of the device.

<sup>(2)</sup> Eco Plan - The planned eco-friendly classification: Pb-Free (RoHS), Pb-Free (RoHS Exempt), or Green (RoHS & no Sb/Br) - please check <http://www.ti.com/productcontent> for the latest availability information and additional product content details.

**TBD:** The Pb-Free/Green conversion plan has not been defined.

**Pb-Free (RoHS):** TI's terms "Lead-Free" or "Pb-Free" mean semiconductor products that are compatible with the current RoHS requirements for all 6 substances, including the requirement that lead not exceed 0.1% by weight in homogeneous materials. Where designed to be soldered at high temperatures, TI Pb-Free products are suitable for use in specified lead-free processes.

**Pb-Free (RoHS Exempt):** This component has a RoHS exemption for either 1) lead-based flip-chip solder bumps used between the die and package, or 2) lead-based die adhesive used between the die and leadframe. The component is otherwise considered Pb-Free (RoHS compatible) as defined above.

**Green (RoHS & no Sb/Br):** TI defines "Green" to mean Pb-Free (RoHS compatible), and free of Bromine (Br) and Antimony (Sb) based flame retardants (Br or Sb do not exceed 0.1% by weight in homogeneous material)

<sup>(3)</sup> MSL, Peak Temp. -- The Moisture Sensitivity Level rating according to the JEDEC industry standard classifications, and peak solder temperature.

**Important Information and Disclaimer:** The information provided on this page represents TI's knowledge and belief as of the date that it is provided. TI bases its knowledge and belief on information provided by third parties, and makes no representation or warranty as to the accuracy of such information. Efforts are underway to better integrate information from third parties. TI has taken and continues to take reasonable steps to provide representative and accurate information but may not have conducted destructive testing or chemical analysis on incoming materials and chemicals. TI and TI suppliers consider certain information to be proprietary, and thus CAS numbers and other limited information may not be available for release.

In no event shall TI's liability arising out of such information exceed the total purchase price of the TI part(s) at issue in this document sold by TI to Customer on an annual basis.

## IMPORTANT NOTICE

Texas Instruments Incorporated and its subsidiaries (TI) reserve the right to make corrections, modifications, enhancements, improvements, and other changes to its products and services at any time and to discontinue any product or service without notice. Customers should obtain the latest relevant information before placing orders and should verify that such information is current and complete. All products are sold subject to TI's terms and conditions of sale supplied at the time of order acknowledgment.

TI warrants performance of its hardware products to the specifications applicable at the time of sale in accordance with TI's standard warranty. Testing and other quality control techniques are used to the extent TI deems necessary to support this warranty. Except where mandated by government requirements, testing of all parameters of each product is not necessarily performed.

TI assumes no liability for applications assistance or customer product design. Customers are responsible for their products and applications using TI components. To minimize the risks associated with customer products and applications, customers should provide adequate design and operating safeguards.

TI does not warrant or represent that any license, either express or implied, is granted under any TI patent right, copyright, mask work right, or other TI intellectual property right relating to any combination, machine, or process in which TI products or services are used. Information published by TI regarding third-party products or services does not constitute a license from TI to use such products or services or a warranty or endorsement thereof. Use of such information may require a license from a third party under the patents or other intellectual property of the third party, or a license from TI under the patents or other intellectual property of TI.

Reproduction of TI information in TI data books or data sheets is permissible only if reproduction is without alteration and is accompanied by all associated warranties, conditions, limitations, and notices. Reproduction of this information with alteration is an unfair and deceptive business practice. TI is not responsible or liable for such altered documentation. Information of third parties may be subject to additional restrictions.

Resale of TI products or services with statements different from or beyond the parameters stated by TI for that product or service voids all express and any implied warranties for the associated TI product or service and is an unfair and deceptive business practice. TI is not responsible or liable for any such statements.

TI products are not authorized for use in safety-critical applications (such as life support) where a failure of the TI product would reasonably be expected to cause severe personal injury or death, unless officers of the parties have executed an agreement specifically governing such use. Buyers represent that they have all necessary expertise in the safety and regulatory ramifications of their applications, and acknowledge and agree that they are solely responsible for all legal, regulatory and safety-related requirements concerning their products and any use of TI products in such safety-critical applications, notwithstanding any applications-related information or support that may be provided by TI. Further, Buyers must fully indemnify TI and its representatives against any damages arising out of the use of TI products in such safety-critical applications.

TI products are neither designed nor intended for use in military/aerospace applications or environments unless the TI products are specifically designated by TI as military-grade or "enhanced plastic." Only products designated by TI as military-grade meet military specifications. Buyers acknowledge and agree that any such use of TI products which TI has not designated as military-grade is solely at the Buyer's risk, and that they are solely responsible for compliance with all legal and regulatory requirements in connection with such use.

TI products are neither designed nor intended for use in automotive applications or environments unless the specific TI products are designated by TI as compliant with ISO/TS 16949 requirements. Buyers acknowledge and agree that, if they use any non-designated products in automotive applications, TI will not be responsible for any failure to meet such requirements.

Following are URLs where you can obtain information on other Texas Instruments products and application solutions:

### Products

Amplifiers	<a href="http://amplifier.ti.com">amplifier.ti.com</a>
Data Converters	<a href="http://dataconverter.ti.com">dataconverter.ti.com</a>
DSP	<a href="http://dsp.ti.com">dsp.ti.com</a>
Clocks and Timers	<a href="http://www.ti.com/clocks">www.ti.com/clocks</a>
Interface	<a href="http://interface.ti.com">interface.ti.com</a>
Logic	<a href="http://logic.ti.com">logic.ti.com</a>
Power Mgmt	<a href="http://power.ti.com">power.ti.com</a>
Microcontrollers	<a href="http://microcontroller.ti.com">microcontroller.ti.com</a>
RFID	<a href="http://www.ti-rfid.com">www.ti-rfid.com</a>
RF/IF and ZigBee® Solutions	<a href="http://www.ti.com/lprf">www.ti.com/lprf</a>

### Applications

Audio	<a href="http://www.ti.com/audio">www.ti.com/audio</a>
Automotive	<a href="http://www.ti.com/automotive">www.ti.com/automotive</a>
Broadband	<a href="http://www.ti.com/broadband">www.ti.com/broadband</a>
Digital Control	<a href="http://www.ti.com/digitalcontrol">www.ti.com/digitalcontrol</a>
Medical	<a href="http://www.ti.com/medical">www.ti.com/medical</a>
Military	<a href="http://www.ti.com/military">www.ti.com/military</a>
Optical Networking	<a href="http://www.ti.com/opticalnetwork">www.ti.com/opticalnetwork</a>
Security	<a href="http://www.ti.com/security">www.ti.com/security</a>
Telephony	<a href="http://www.ti.com/telephony">www.ti.com/telephony</a>
Video & Imaging	<a href="http://www.ti.com/video">www.ti.com/video</a>
Wireless	<a href="http://www.ti.com/wireless">www.ti.com/wireless</a>

Mailing Address: Texas Instruments, Post Office Box 655303, Dallas, Texas 75265  
Copyright © 2008, Texas Instruments Incorporated