

DO NOT  
SCALE FROM  
THIS PRINT

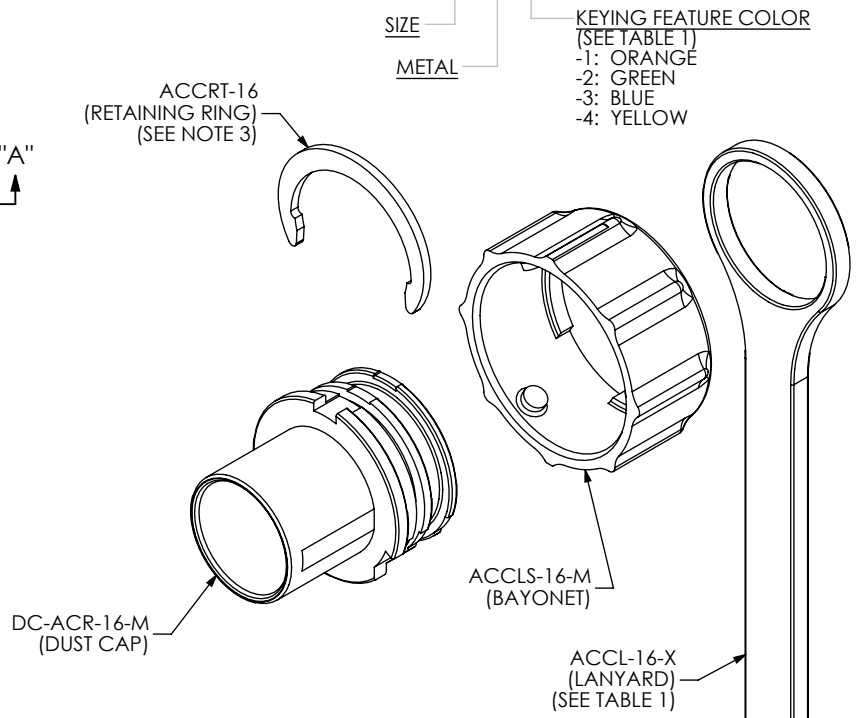
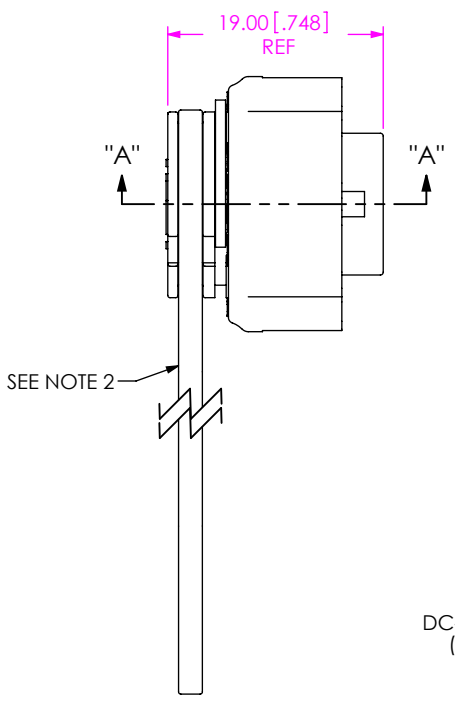
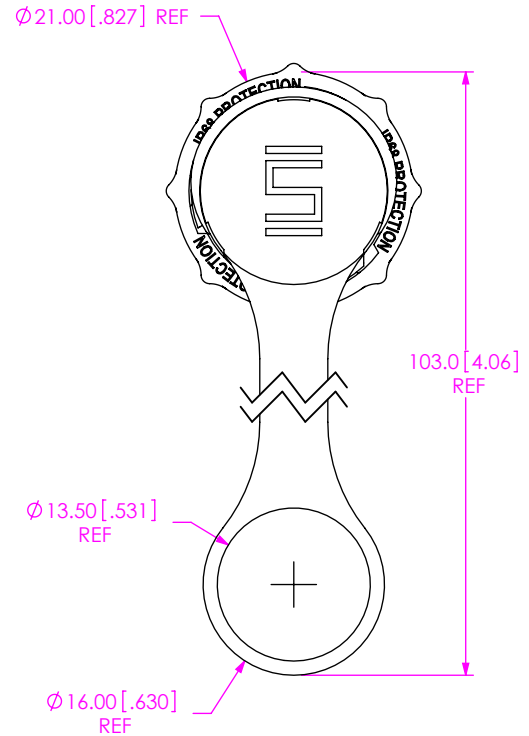

SIZE METAL

KEYING FEATURE COLOR (SEE TABLE 1)

- 1: ORANGE
- 2: GREEN
- 3: BLUE
- 4: YELLOW

APPLICATION VIEW

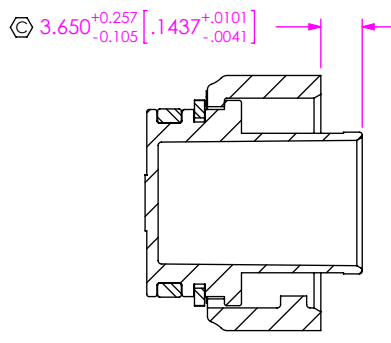
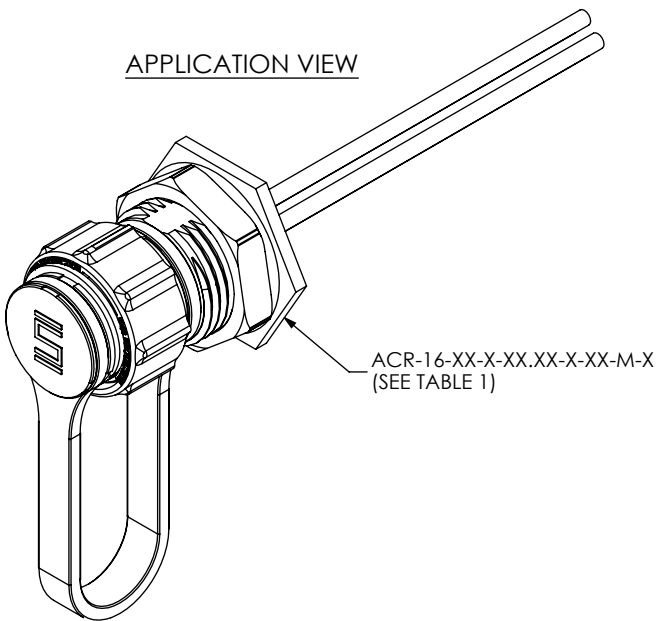

SECTION "A"- "A"

TABLE 1

CORRESPONDING CABLE PART NUMBER	KEYING FEATURE COLOR	ACCL-16-X
ACR-16-XX-X-XX.XX-X-XX-M-1	-1	ACCL-16-1
ACR-16-XX-X-XX.XX-X-XX-M-2	-2	ACCL-16-2
ACR-16-XX-X-XX.XX-X-XX-M-3	-3	ACCL-16-3
ACR-16-XX-X-XX.XX-X-XX-M-4	-4	ACCL-16-4

NOTES:

1. Ⓢ REPRESENTS A CRITICAL DIMENSION.
2. ACCL-16-X MUST SEAT IN GROOVE IN DC-ACR-16-M.
3. SNAP ACCRT-16 INTO GROOVE ON DC-ACR-16-M.

UNLESS OTHERWISE SPECIFIED,  
DIMENSIONS ARE IN MILLIMETERS.  
TOLERANCES ARE:  
DECIMALS ANGLES  
X.X: ±0.3 [.01] 2°  
X.XX: ±0.13 [.005]  
X.XXX: ±0.051 [.0020]

PROPRIETARY NOTE  
THIS DOCUMENT CONTAINS INFORMATION  
CONFIDENTIAL AND PROPRIETARY TO  
SAMTEC, INC. AND SHALL NOT BE REPRODUCED  
OR TRANSFERRED TO OTHER DOCUMENTS OR  
DISCLOSED TO OTHERS OR USED FOR ANY  
PURPOSE OTHER THAN THAT WHICH IT WAS  
OBTAINED WITHOUT THE EXPRESSED WRITTEN  
CONSENT OF SAMTEC, INC.



520 PARK EAST BLVD., NEW ALBANY, IN 47150  
PHONE: 812-944-6733 FAX: 812-948-5047  
e-Mail: info@SAMTEC.com code 53322

MATERIAL: DO NOT SCALE DRAWING SHEET SCALE: 1.5:1  
DC-ACR-16-M: ZINC ALLOY  
ACCLS-16-M: ZINC ALLOY  
ACCRT-16: STAINLESS STEEL  
ACCL-16-X: SILICONE

DESCRIPTION:  
ACCLIMATE CIRC. PANEL DUST CAP

DWG. NO. DCA-ACR-16-M-X

BY: D.SCHMELZ 04/26/2010 SHEET 1 OF 1