

## Dual-Channel Synchronous Rectified MOSFET Driver

### General Description

The RT9625B is a high frequency, synchronous rectified, two phase MOSFET driver designed for normal MOSFET driving applications and high performance CPU VR driving capabilities.

The RT9625B can be supplied from 4.5V to 13.2V. The applicable power stage VIN range is from 5V to 23V. The RT9625B also builds in internal power switches to replace external bootstrap diodes.

The RT9625B can support switching frequency efficiently up to 500kHz. The RT9625B has the UGATE and LGATE driving circuits for synchronous rectified DC/DC converter applications. The shoot through protection mechanism is designed to prevent shoot through between high side and low side power MOSFETs. The RT9625B has tri-state PWM input with shutdown function, which can force driver to output low UGATE and LGATE signals.

The RT9625 comes in a small footprint with WQFN-16L 4x4 package.

### Features

- Drive Four N-MOSFETs for Two-Phase PWM Control
- Shoot Through Protection
- Embedded Bootstrap Diode
- Support High Switching Frequency
- Fast Output Rising Time
- Tri-State PWM Input for Output Shutdown
- Small 16-Lead WQFN Package
- RoHS Compliant and Halogen Free

### Applications

- Core Voltage Supplies for Desktop, Motherboard CPU
- High Frequency Low Profile DC/DC Converters
- High Current Low Voltage DC/DC Converters
- Core Voltage Supplies for GFX Card

### Marking Information

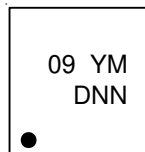

09 : Product Code  
YMDNN : Date Code

### Simplified Application Circuit

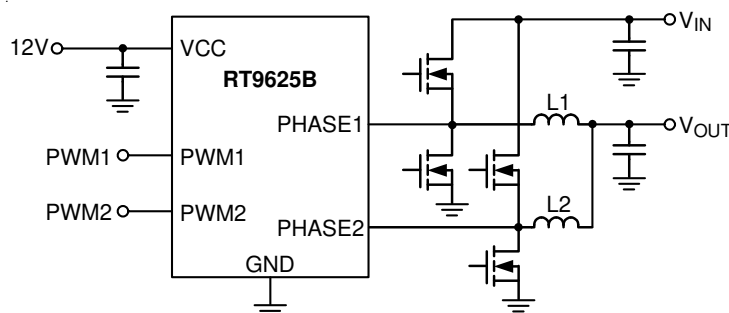

## Ordering Information

RT9625B □ □

- Package Type  
QW : WQFN-16L 4x4 (W-Type)
- Lead Plating System  
Z : ECO (Ecological Element with Halogen Free and Pb free)

Note :

Richtek products are :

- ▶ RoHS compliant and compatible with the current requirements of IPC/JEDEC J-STD-020.
- ▶ Suitable for use in SnPb or Pb-free soldering processes.

## Pin Configurations

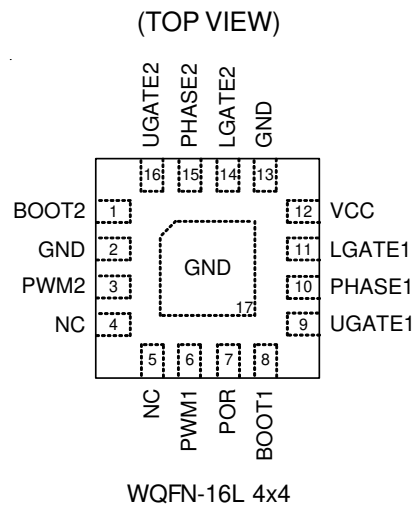

## Function Pin Description

Pin No.	Pin Name	Pin Function
1	BOOT2	Bootstrap Power Pins for Channel 2 and Channel 1. This pin powers the high side MOSFET driver. Connect this pin to the junction of the bootstrap capacitor and the cathode of the bootstrap diode.
8	BOOT1	
2, 13 (Exposed Pad)	GND	Ground. The exposed pad must be soldered to a large PCB and connected to GND for maximum power dissipation.
3	PWM2	PWM Signal Input. Connect this pin to the PWM output of the controller.
6	PWM1	
4, 5	NC	No Internal Connection.
7	POR	Power On Reset Signal.
9	UGATE1	High Side Gate Drive Outputs for channel 1 and channel 2. Connect this pin to Gate of high side power MOSFET.
16	UGATE2	
10	PHASE1	Switch Nodes of High Side Driver 1 and Driver 2. Connect this pin to the high side MOSFET Source together with the low side MOSFET Drain and the inductor.
15	PHASE2	
11	LGATE1	Low Side Gate Drive Output for Channel 1 and Channel 2. This pin drives the Gate of low side MOSFET.
14	LGATE2	
12	VCC	Supply Input. VCC supplies current for Channel 1 and Channel 2 gate drivers.

**Function Block Diagram**

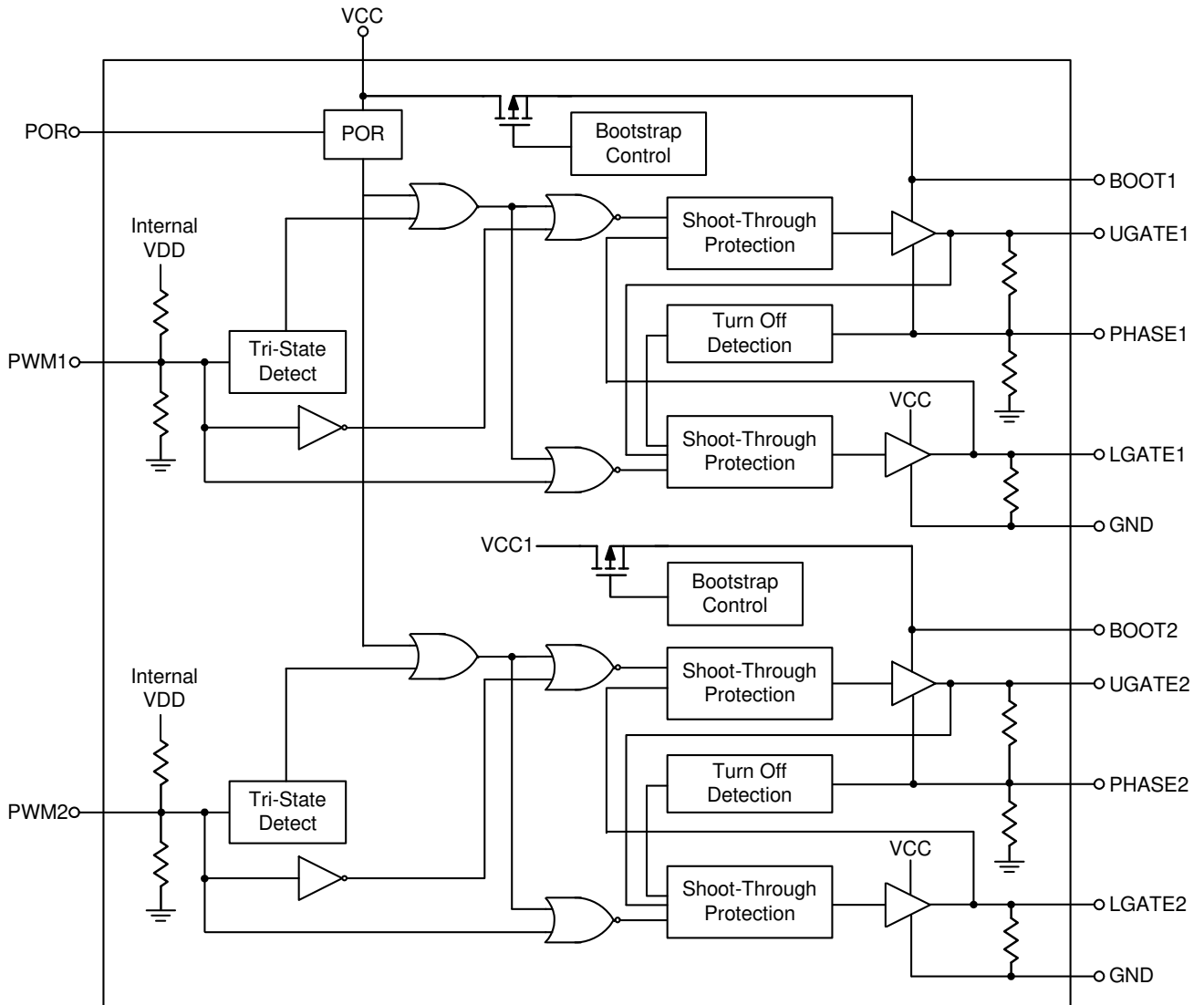

## Operation

### POR (Power On Reset)

POR block detects the voltages at VCC pin. When the VCC pin voltage is higher than POR rising threshold, POR pin output voltage (POR output) is high. POR output is low when VCC is not higher than POR rising threshold. When the POR pin voltage is high, UGATE<sub>x</sub> and LGATE<sub>x</sub> can be controlled by PWM<sub>x</sub> input voltage. If the POR pin voltage is low, both UGATE<sub>x</sub> and LGATE<sub>x</sub> will be pulled to low.

### Tri-State Detect

When both POR block output and EN<sub>x</sub> pin voltages are high, UGATE<sub>x</sub> and LGATE<sub>x</sub> can be controlled by PWM<sub>x</sub> input. There are three PWM<sub>x</sub> input modes, which are high, low, and shutdown state. If PWM<sub>x</sub> input is within the shutdown window, both UGATE<sub>x</sub> and LGATE<sub>x</sub> output are low. When PWM<sub>x</sub> input is higher than its rising threshold, UGATE<sub>x</sub> is high and LGATE<sub>x</sub> is low. When PWM<sub>x</sub> input is lower than its falling threshold, UGATE<sub>x</sub> is low and LGATE<sub>x</sub> is high.

### Bootstrap Control

Bootstrap control block controls the integrated bootstrap switch. When LGATE<sub>x</sub> is high (low side MOSFET is turned on), the bootstrap switch is turned on to charge the bootstrap capacitor connected to BOOT<sub>x</sub> pin. When LGATE<sub>x</sub> is low (low side MOSFET is turned off), the bootstrap switch is turned off to disconnect VCC pin and BOOT<sub>x</sub> pin.

### Turn-Off Detection

Turn-off detection block detects whether high side MOSFET is turned off by monitoring PHASE<sub>x</sub> pin voltage. To avoid shoot through between high side and low side MOSFETs, low side MOSFET can be turned on only after high side MOSFET is effectively turned off.

### Shoot-Through Protection

Shoot-through protection block implements the dead time when both high side and low side MOSFETs are turned off. With shoot-through protection block, high side and low side MOSFET are never turned on simultaneously. Thus, shoot through between high side and low side MOSFETs is prevented.

**Absolute Maximum Ratings** (Note 1)

- Supply Voltage, VCC ----- -0.3V to 15V
- BOOTx to PHASEx ----- -0.3V to 15V
- PHASEx to GND
  - DC ----- -0.3V to 30V
  - < 100ns ----- -10V to 35V
- LGATEx to GND
  - DC ----- -0.3V to (VCC + 0.3V)
  - < 100ns ----- -2V to (VCC + 0.3V)
- UGATEx to GND
  - DC ----- (V<sub>PHASE</sub> - 0.3V) to (V<sub>BOOT</sub> + 0.3V)
  - < 100ns ----- (V<sub>PHASE</sub> - 2V) to (V<sub>BOOT</sub> + 0.3V)
- PWMx to GND ----- -0.3V to 7V
- POR to GND ----- -0.3V to 5V
- Power Dissipation, P<sub>D</sub> @ T<sub>A</sub> = 25°C
  - WQFN-16L 4x4 ----- 1.852W
- Package Thermal Resistance (Note 2)
  - WQFN-16L 4x4, θ<sub>JA</sub> ----- 54°C/W
  - WQFN-16L 4x4, θ<sub>JC</sub> ----- 7°C/W
- Lead Temperature (Soldering, 10 sec.) ----- 260°C
- Junction Temperature ----- 150°C
- Storage Temperature Range ----- -65°C to 150°C
- ESD Susceptibility (Note 3)
  - HBM (Human Body Model) ----- 2kV

**Recommended Operating Conditions** (Note 4)

- Supply Voltage, VCC ----- 4.5V to 13.2V
- Input Voltage, (V<sub>IN</sub> + VCC) ----- < 35V
- Junction Temperature Range ----- -40°C to 125°C
- Ambient Temperature Range ----- -40°C to 85°C

**Electrical Characteristics**

(V<sub>CC</sub> = 12V, T<sub>A</sub> = 25°C unless otherwise specified)

Parameter	Symbol	Test Conditions	Min	Typ	Max	Unit
Power Supply Voltage	V <sub>CC</sub>		4.5	--	13.2	V
Power Supply Current	I <sub>VCC</sub>	V <sub>BOOTx</sub> = 12V, PWMx Floating	--	180	--	μA
<b>Power On Reset (POR)</b>						
POR Rising Threshold	V <sub>POR_r</sub>	V <sub>CC</sub> Rising	--	4	4.4	V
POR Falling Threshold	V <sub>POR_f</sub>	V <sub>CC</sub> Falling	3	3.5	--	V
POR Pin High Voltage	V <sub>POR_H</sub>		--	3.5	4	V
POR Pin Low Voltage	V <sub>POR_L</sub>		--	--	0.5	V

Parameter	Symbol	Test Conditions	Min	Typ	Max	Unit
<b>PWM Input</b>						
Maximum Input Current	$I_{PWM}$	$V_{PWMx} = 0V \text{ or } 5V$	--	160	--	$\mu A$
PWMx Floating Voltage	$V_{PWM\_fl}$	PWMx = Open	--	1.8	--	V
PWMx Rising Threshold	$V_{PWM\_rth}$		2.3	2.8	3.2	V
PWMx Falling Threshold	$V_{PWM\_fth}$		0.7	1.1	1.4	V
<b>Timing</b>						
UGATEx Rising Time	$t_{UGATEr}$	3nF load	--	25	--	ns
UGATEx Falling Time	$t_{UGATEf}$	3nF load	--	12	--	ns
LGATEx Rising Time	$t_{LGATER}$	3nF load	--	24	--	ns
LGATEx Falling Time	$t_{LGATEf}$	3nF load	--	10	--	ns
Propagation Delay	$t_{UGATEpdh}$	$V_{BOOTx} - V_{PHASEx} = 12V$ See Timing Diagram	--	60	--	ns
	$t_{UGATEpdl}$		--	22	--	
	$t_{LGATEpdh}$	See Timing Diagram	--	30	--	ns
	$t_{LGATEpdl}$		--	8	--	
<b>Output</b>						
UGATEx Drive Source	$R_{UGATEsr}$	$V_{BOOT} - V_{PHASE} = 12V, I_{Source} = 100mA$	--	1.7	--	$\Omega$
UGATEx Drive Sink	$R_{UGATEsk}$	$V_{BOOT} - V_{PHASE} = 12V, I_{Sink} = 100mA$	--	1.4	--	$\Omega$
LGATEx Drive Source	$R_{LGATEsr}$	$I_{Source} = 100mA$	--	1.6	--	$\Omega$
LGATEx Drive Sink	$R_{LGATEsk}$	$I_{Sink} = 100mA$	--	1.1	--	$\Omega$

**Note 1.** Stresses beyond those listed “Absolute Maximum Ratings” may cause permanent damage to the device. These are stress ratings only, and functional operation of the device at these or any other conditions beyond those indicated in the operational sections of the specifications is not implied. Exposure to absolute maximum rating conditions may affect device reliability.

**Note 2.**  $\theta_{JA}$  is measured at  $T_A = 25^\circ C$  on a high effective thermal conductivity four-layer test board per JEDEC 51-7.  $\theta_{JC}$  is measured at the exposed pad of the package.

**Note 3.** Devices are ESD sensitive. Handling precaution is recommended.

**Note 4.** The device is not guaranteed to function outside its operating conditions.

**Typical Application Circuit**

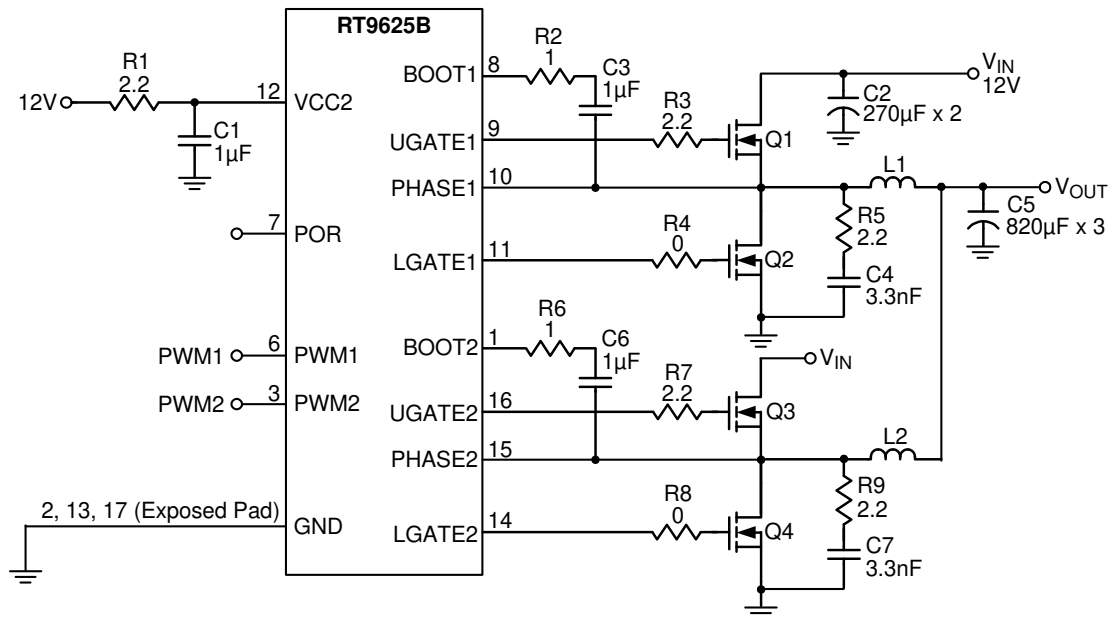

**Timing Diagram**

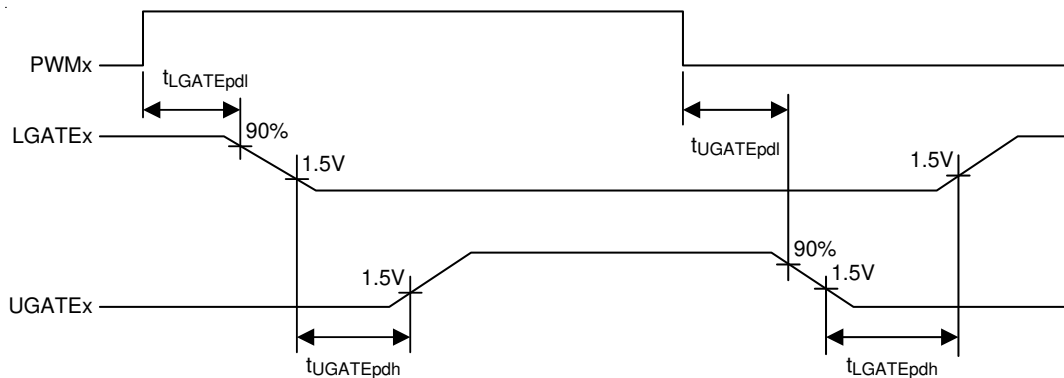

Typical Operating Characteristics

PWM Rising Edge

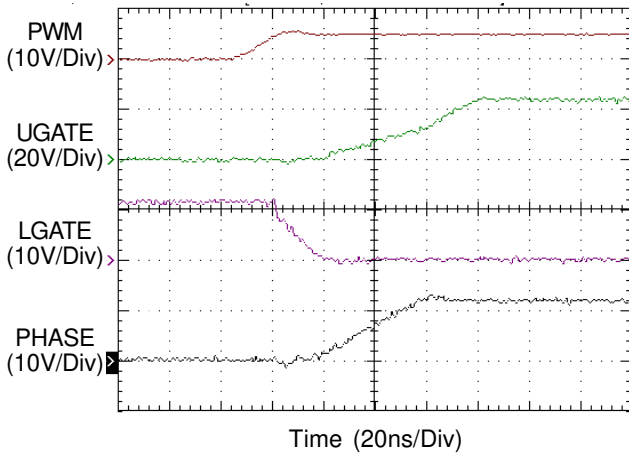

PWM Falling Edge

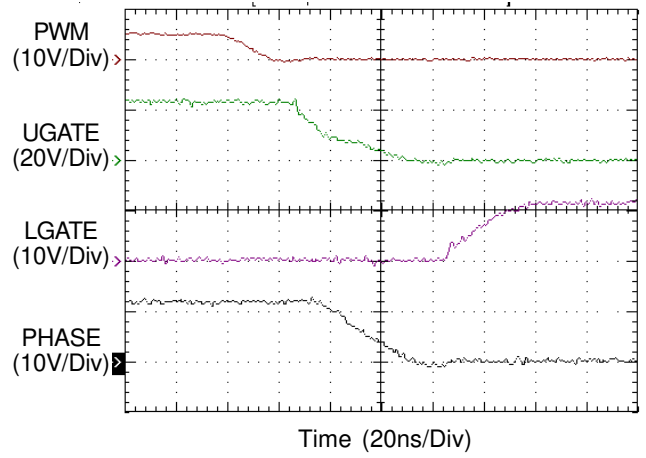

Dead Time

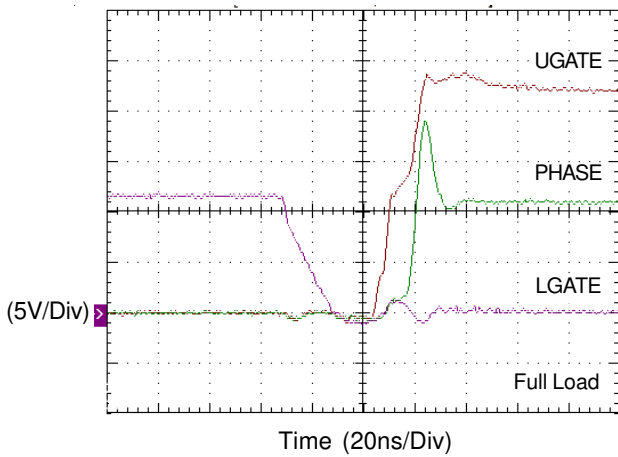

Dead Time

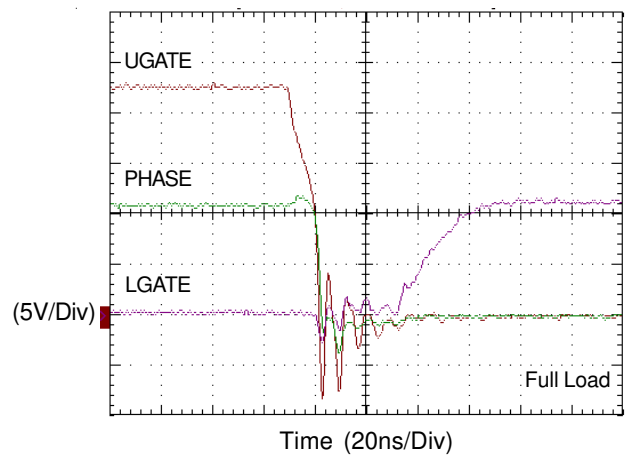

Dead Time

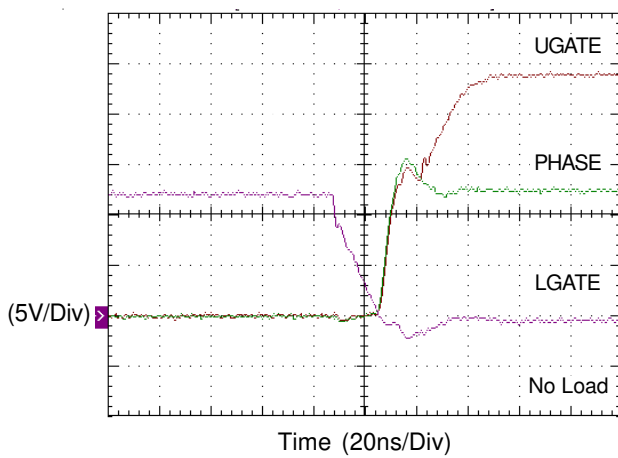

Dead Time

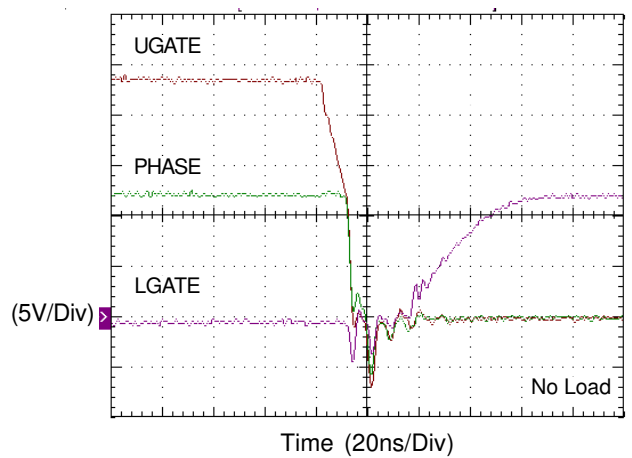



**Short Pulse**

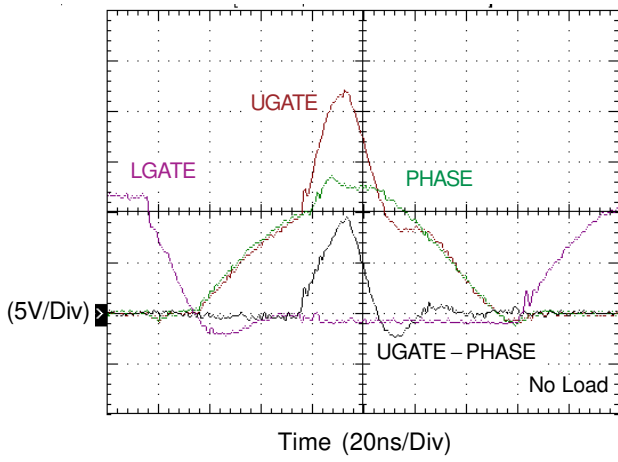

## Application Information

The RT9625B is a high frequency, two-channel synchronous rectified MOSFET driver containing Richtek's advanced MOSFET driver technologies. The RT9625B is designed to be able to adapt from normal MOSFET driving applications to high performance CPU VR driving capabilities.

### Supply Voltage and Power On Reset

The RT9625B can be utilized under both  $V_{CC} = 5V$  or  $V_{CC} = 12V$  applications which may happen in different fields of electronics application circuits. In terms of efficiency, higher  $V_{CC}$  equals higher driving voltage of UGATEx/LGATEx which may result in higher switching loss and lower conduction loss of power MOSFETs. The choice of  $V_{CC} = 12V$  or  $V_{CC} = 5V$  can be a tradeoff to optimize system efficiency.

The RT9625B controls both high side and low side N-MOSFETs of two half-bridge power according to two external input PWMx control signals. It has Power On Reset (POR) function which held UGATEx and LGATEx low before the VCC voltage rises to higher than rising threshold voltage. When  $V_{CC}$  exceeds the POR threshold voltage, the voltage at the POR pin will be pulled high.

### Tri-state PWM Input

After the initialization, the PWMx signal takes the control. The rising PWMx signal first forces the LGATEx signal to turn low then UGATEx signal is allowed to go high just after a non-overlapping time to avoid shoot through current. The falling of PWMx signal first forces UGATEx to go low. When UGATEx and PHASEx signal reach a predetermined low level, LGATEx signal is allowed to turn high.

The PWMx signal is acted as "High" if the signal is above the rising threshold and acted as "Low" if the signal is below the falling threshold. When PWM signal level enters and remains within the shutdown window, the output drivers are disabled and both MOSFET gates are pulled and held low. If the PWMx signal is left floating, the pin will be kept around 1.8V by the internal divider and provide the PWMx controller with a recognizable level.

### Bootstrap Power Switch

The RT9625B builds in internal bootstrap power switches to replace external bootstrap diode, and this can facilitate PCB design and reduce total BOM cost of the system. Hence, no external bootstrap diode is required in real applications.

### Non-overlap Control

To prevent the overlap of the gate drivers during the UGATEx pull low and the LGATEx pull high, the non-overlap circuit monitors the voltages at the PHASEx node and high side gate drive (UGATEx – PHASEx). When the PWMx input signal goes low, UGATEx begins to pull low (after propagation delay). Before LGATEx is pulled high, the non-overlap protection circuit ensures that the monitored voltages have gone below 1.1V. Once the monitored voltages fall below 1.1V, LGATEx begins to turn high. By waiting for the voltages of the PHASEx pin and high side gate driver to fall below 1.1V, the non-overlap protection circuit ensures that UGATEx is low before LGATEx pulls high.

Also to prevent the overlap of the gate drivers during LGATEx pull low and UGATEx pull high, the non-overlap circuit monitors the LGATEx voltage. When LGATEx goes below 1.1V, UGATEx goes high after propagation delay.

### Driving Power MOSFETs

The DC input impedance of the power MOSFET is extremely high. When  $V_{gs1}$  or  $V_{gs2}$  is at 12V or 5V, the gate draws the current only for few nano-amperes. Thus once the gate has been driven up to "ON" level, the current could be negligible.

However, the capacitance at the gate to source terminal should be considered. It requires relatively large currents to drive the gate up and down 12V (or 5V) rapidly. It is also required to switch drain current on and off with the required speed. The required gate drive currents are calculated as follows.

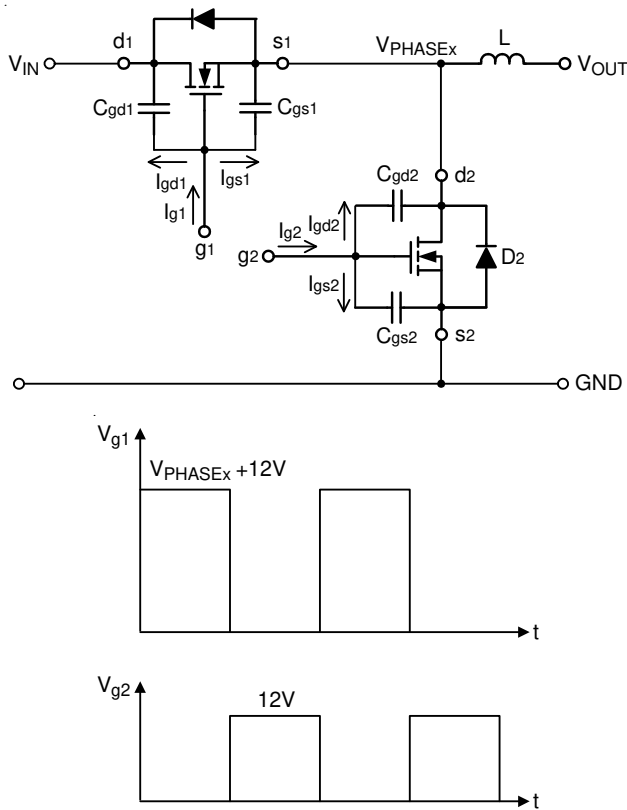

Figure 1. Equivalent Circuit and Waveforms ( $V_{CC} = 12V$ )

In Figure 1, the current  $I_{g1}$  and  $I_{g2}$  are required to move the gate up to 12V. The operation consists of charging  $C_{gd1}$ ,  $C_{gd2}$ ,  $C_{gs1}$  and  $C_{gs2}$ .  $C_{gs1}$  and  $C_{gs2}$  are the capacitors from gate to source of the high side and the low side power MOSFETs, respectively. In general data sheets, the  $C_{gs1}$  and  $C_{gs2}$  are referred as “ $C_{iss}$ ” which are the input capacitors.  $C_{gd1}$  and  $C_{gd2}$  are the capacitors from gate to drain of the high side and the low side power MOSFETs, respectively and referred to the data sheets as “ $C_{rss}$ ” the reverse transfer capacitance. For example,  $t_{r1}$  and  $t_{r2}$  are the rising time of the high side and the low side power MOSFETs respectively, the required current  $I_{gs1}$  and  $I_{gs2}$ , are shown as below :

$$I_{gs1} = C_{gs1} \frac{dV_{g1}}{dt} = \frac{C_{gs1} \times 12}{t_{r1}} \quad (1)$$

$$I_{gs2} = C_{gs2} \frac{dV_{g2}}{dt} = \frac{C_{gs2} \times 12}{t_{r2}} \quad (2)$$

Before driving the gate of the high side MOSFET up to 12V, the low side MOSFET has to be off; and the high side MOSFET will be turned off before the

low side is turned on. From Figure 1, the body diode “ $D_2$ ” will be turned on before high side MOSFETs turn on.

$$I_{gd1} = C_{gd1} \frac{dV}{dt} = C_{gd1} \frac{12}{t_{r1}} \quad (3)$$

Before the low side MOSFET is turned on, the  $C_{gd2}$  have been charged to  $V_{IN}$ . Thus, as  $C_{gd2}$  reverses its polarity and  $g_2$  is charged up to 12V, the required current is

$$I_{gd2} = C_{gd2} \frac{dV}{dt} = C_{gd2} \frac{V_{IN} + 12}{t_{r2}} \quad (4)$$

It is helpful to calculate these currents in a typical case. Assume a synchronous rectified Buck converter, input voltage  $V_{IN} = 12V$ ,  $V_{gs1} = 12V$ ,  $V_{gs2} = 12V$ . The high side MOSFET is PHB83N03LT whose  $C_{iss} = 1660pF$ ,  $C_{rss} = 380pF$ , and  $t_r = 14ns$ . The low side MOSFET is PHB95N03LT whose  $C_{iss} = 2200pF$ ,  $C_{rss} = 500pF$  and  $t_r = 30ns$ , from the equation (1) and (2) we can obtain

$$I_{gs1} = \frac{1660 \times 10^{-12} \times 12}{14 \times 10^{-9}} = 1.428 \quad (A) \quad (5)$$

$$I_{gs2} = \frac{2200 \times 10^{-12} \times 12}{30 \times 10^{-9}} = 0.88 \quad (A) \quad (6)$$

from equation. (3) and (4)

$$I_{gd1} = \frac{380 \times 10^{-12} \times 12}{14 \times 10^{-9}} = 0.326 \quad (A) \quad (7)$$

$$I_{gd2} = \frac{500 \times 10^{-12} \times (12+12)}{30 \times 10^{-9}} = 0.4 \quad (A) \quad (8)$$

the total current required from the gate driving source can be calculated as following equations.

$$I_{g1} = I_{gs1} + I_{gd1} = (1.428 + 0.326) = 1.754 \quad (A) \quad (9)$$

$$I_{g2} = I_{gs2} + I_{gd2} = (0.88 + 0.4) = 1.28 \quad (A) \quad (10)$$

By a similar calculation, we can also get the sink current required from the turned off MOSFET.

## Select the Bootstrap Capacitor

Figure 2 shows part of the bootstrap circuit of the RT9625B. The  $V_{CB}$  (the voltage difference between  $BOOTx$  and  $PHASEx$  on RT9625B) provides a voltage to the gate of the high side power MOSFET. This supply needs to be ensured that the MOSFET can be driven. For this, the capacitance  $C_{BOOT}$  has to be selected properly. It is determined by the following constraints.

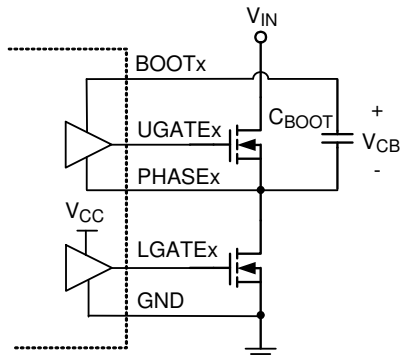

Figure 2. Part of Bootstrap Circuit of RT9625B

In practice, a low value capacitor  $C_{BOOT}$  will lead to the over charging that could damage the IC. Therefore, to minimize the risk of overcharging and to reduce the ripple on  $V_{CB}$ , the bootstrap capacitor should not be smaller than  $0.1\mu F$ , and the larger the better. In general design, using  $1\mu F$  can provide better performance. At least one low-ESR capacitor should be used to provide good local de-coupling. It is recommended to adopt a ceramic or tantalum capacitor.

## Power Dissipation

To prevent driving the IC beyond the maximum recommended operating junction temperature of  $125^{\circ}C$ , it is necessary to calculate the power dissipation appropriately. This dissipation is a function of switching frequency and total gate charge of the selected MOSFET.

Figure 3 shows the power dissipation test circuit.  $C_L$  and  $C_U$  are the  $UGATEx$  and  $LGATEx$  load capacitors, respectively. The bootstrap capacitor value is  $1\mu F$ .

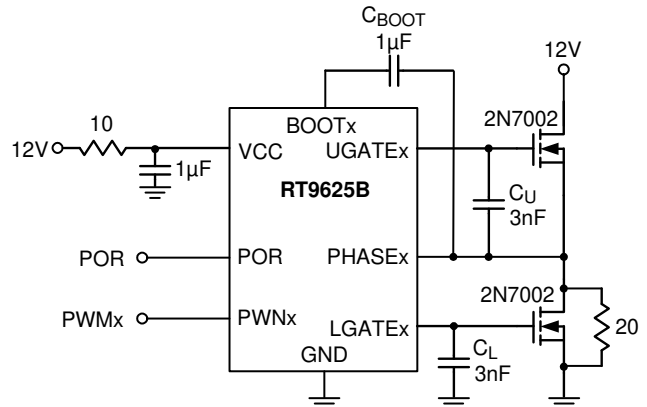

Figure 3. Power Dissipation Test Circuit

Figure 4 shows the power dissipation of the RT9625B as a function of frequency and load capacitance when  $V_{CC} = 12V$ . The value of  $C_U$  and  $C_L$  are the same and the frequency is varied from  $100kHz$  to  $1MHz$ .

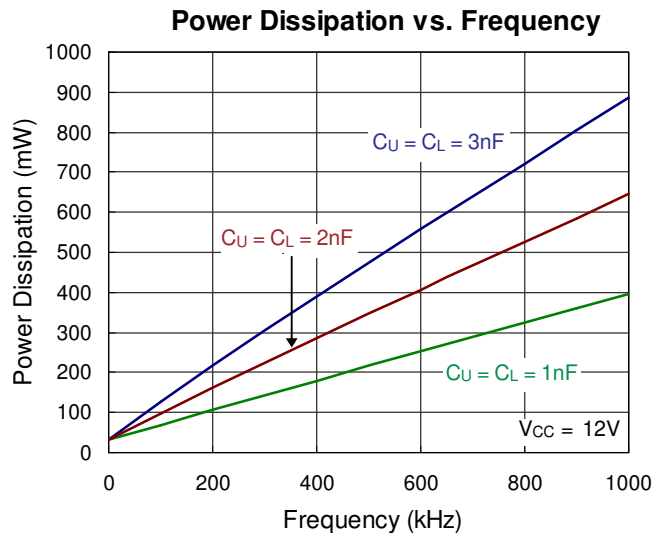

Figure 4. Power Dissipation vs. Frequency

The operating junction temperature can be calculated from the power dissipation curves (Figure 4). Assume  $V_{CC} = 12V$ , operating frequency is  $200kHz$  and  $C_U = C_L = 1nF$  which emulate the input capacitances of the high side and low side power MOSFETs. From Figure 4, the power dissipation is  $100mW$ . Thus, for example, with the SOP-8 package, the package thermal resistance  $\theta_{JA}$  is  $120^{\circ}C/W$ . The operating junction temperature is then calculated as :

$$T_J = (120^{\circ}C/W \times 100mW) + 25^{\circ}C = 37^{\circ}C \quad (11)$$

where the ambient temperature is  $25^{\circ}C$ .

**Thermal Considerations**

For continuous operation, do not exceed absolute maximum junction temperature. The maximum power dissipation depends on the thermal resistance of the IC package, PCB layout, rate of surrounding airflow, and difference between junction and ambient temperature. The maximum power dissipation can be calculated by the following formula :

$$P_{D(MAX)} = (T_{J(MAX)} - T_A) / \theta_{JA}$$

where  $T_{J(MAX)}$  is the maximum junction temperature,  $T_A$  is the ambient temperature, and  $\theta_{JA}$  is the junction to ambient thermal resistance.

For recommended operating condition specifications of the RT9625B, the maximum junction temperature is 125°C. The junction to ambient thermal resistance,  $\theta_{JA}$ , is layout dependent. For WQFN-16L 4x4 packages, the thermal resistance,  $\theta_{JA}$ , is 54°C/W on a standard JEDEC 51-7 four-layer thermal test board. The maximum power dissipation at  $T_A = 25^\circ\text{C}$  can be calculated by the following formula :

$$P_{D(MAX)} = (125^\circ\text{C} - 25^\circ\text{C}) / (54^\circ\text{C/W}) = 1.852\text{W}$$

for WQFN-16L 4x4 package

The maximum power dissipation depends on the operating ambient temperature for fixed  $T_{J(MAX)}$  and thermal resistance,  $\theta_{JA}$ . The derating curve in Figure 5 allows the designer to see the effect of rising ambient temperature on the maximum power dissipation.

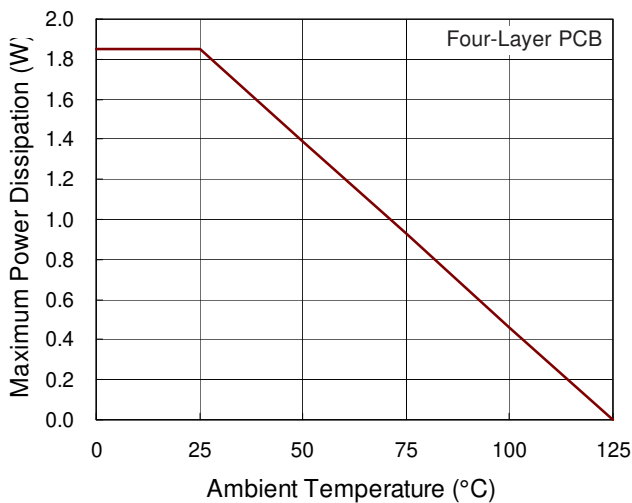

Figure 5. Derating Curve of Maximum Power Dissipation

**Layout Consideration**

Figure 6 shows the schematic circuit of a synchronous buck converter to implement the RT9625B. The converter operates from 5V to 12V of input Voltage.

For the PCB layout, it should be very careful. The power circuit section is the most critical one. If not configured properly, it will generate a large amount of EMI. The location of  $Q_{UGx}$ ,  $Q_{LGx}$ ,  $L_x$  should be very close.

Next, the trace from  $UGATE_x$ , and  $LGATE_x$  should also be short to decrease the noise of the driver output signals.  $PHASE_x$  signals from the junction of the power MOSFET, carrying the large gate drive current pulses, should be as heavy as the gate drive trace. The bypass capacitor  $C_{VCC}$  should be connected to GND directly. Furthermore, the bootstrap capacitors ( $C_{BOOTx}$ ) should always be placed as close to the pins of the IC as possible.

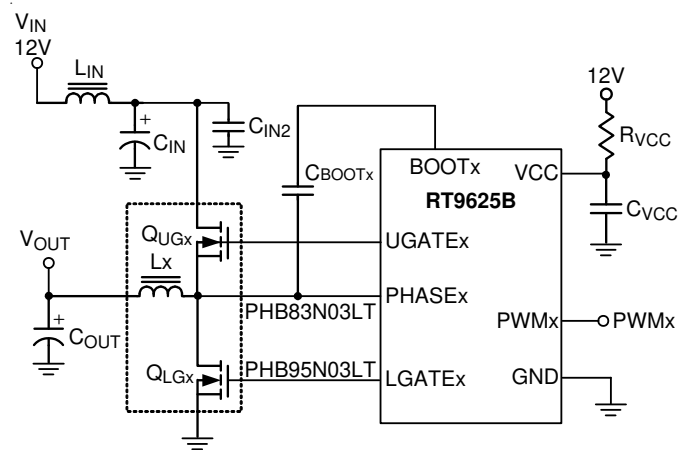
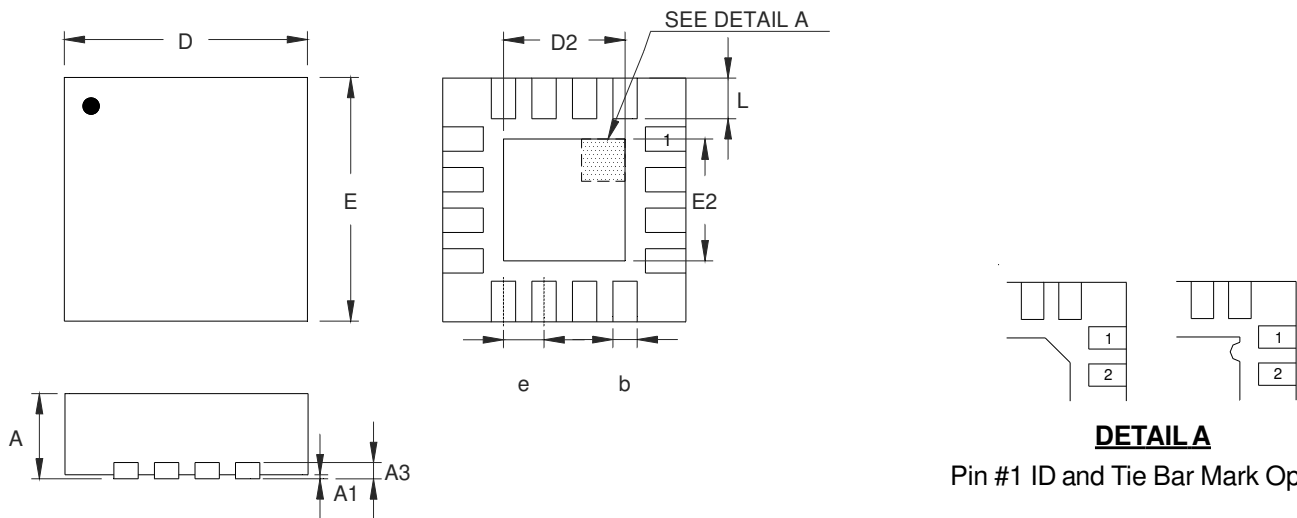

Figure 6. Synchronous Buck Converter Circuit

## Outline Dimension



### DETAIL A

Pin #1 ID and Tie Bar Mark Options

Note : The configuration of the Pin #1 identifier is optional, but must be located within the zone indicated.

Symbol	Dimensions In Millimeters		Dimensions In Inches	
	Min	Max	Min	Max
A	0.700	0.800	0.028	0.031
A1	0.000	0.050	0.000	0.002
A3	0.175	0.250	0.007	0.010
b	0.250	0.380	0.010	0.015
D	3.950	4.050	0.156	0.159
D2	2.000	2.450	0.079	0.096
E	3.950	4.050	0.156	0.159
E2	2.000	2.450	0.079	0.096
e	0.650		0.026	
L	0.500	0.600	0.020	0.024

### W-Type 16L QFN 4x4 Package

## Richtek Technology Corporation

14F, No. 8, Tai Yuen 1<sup>st</sup> Street, Chupei City  
 Hsinchu, Taiwan, R.O.C.  
 Tel: (8863)5526789

Richtek products are sold by description only. Richtek reserves the right to change the circuitry and/or specifications without notice at any time. Customers should obtain the latest relevant information and data sheets before placing orders and should verify that such information is current and complete. Richtek cannot assume responsibility for use of any circuitry other than circuitry entirely embodied in a Richtek product. Information furnished by Richtek is believed to be accurate and reliable. However, no responsibility is assumed by Richtek or its subsidiaries for its use; nor for any infringements of patents or other rights of third parties which may result from its use. No license is granted by implication or otherwise under any patent or patent rights of Richtek or its subsidiaries.