

THIS DOCUMENT IS THE PROPERTY OF KEYSTONE ELECTRONICS CORP. AND SHALL NOT BE REPRODUCED, DISTRIBUTED OR USED AS A BASIS FOR MANUFACTURE WITHOUT PRIOR WRITTEN PERMISSION FROM KEYSTONE ELECTRONICS CORP.

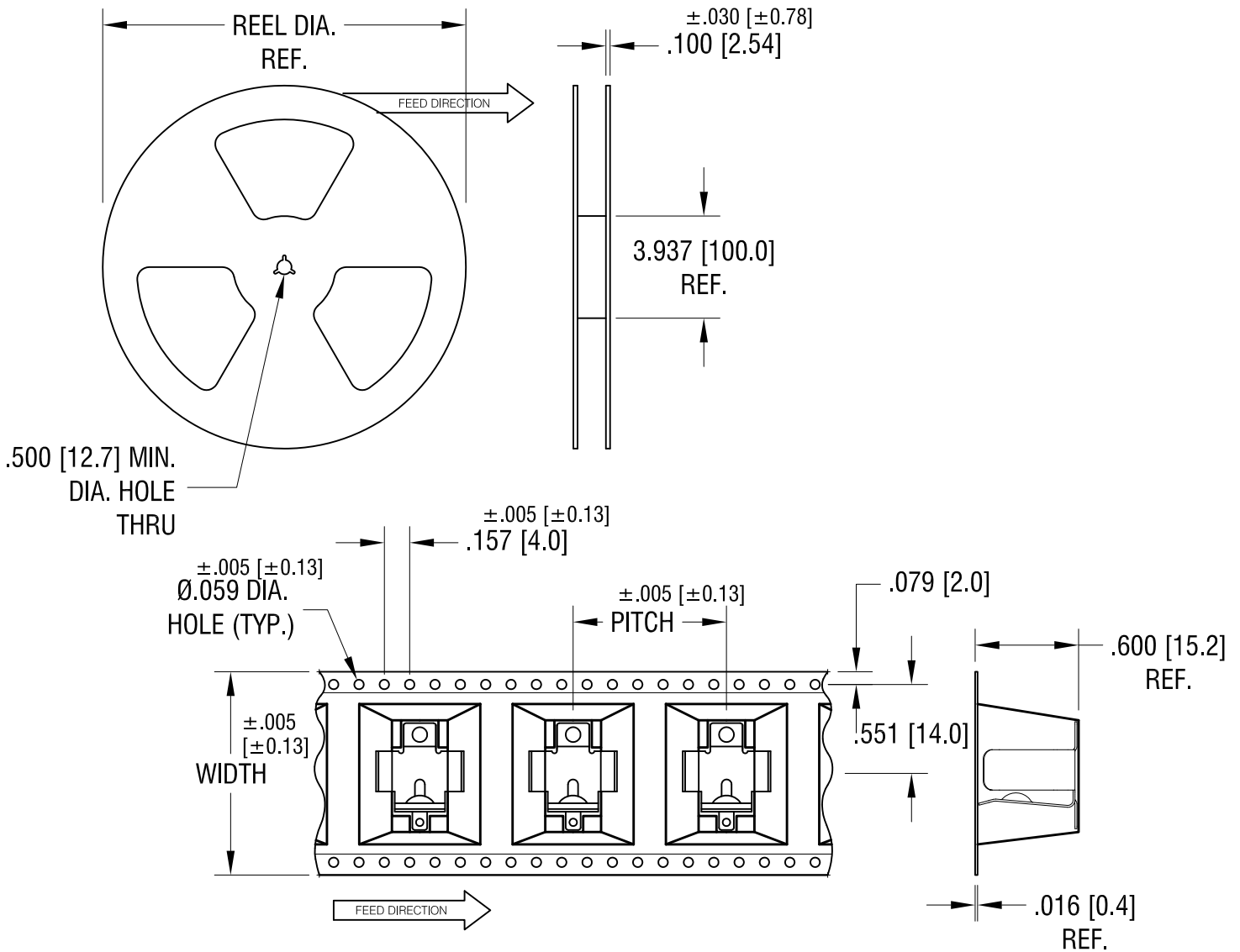

**NOTES:**

**TAPE AND REEL SPECIFICATIONS:**

**1. TAPE:**

MAT'L - ALL CONDUCTIVE POLYSTYRENE CARRIER  
 ANSI/EIA-481 STANDARD  
 1.260 [32.0] WIDE; .950 [24.0] PITCH

**2. REEL:**

15.0 [380.8] DIA. 150 PIECES  
 OF PART NO. 553 PER REEL.

4.12.12	CHANGE AS PER ECN 12-048	B
3.07.11	CHANGE AS PER ECN 11-029	A
DATE	DESCRIPTION	REV.

<b>KEYSTONE ELECTRONICS CORP.</b>			
www.keyelco.com • ASTORIA, N.Y. 11105-2017 • Tel (718) 956-8900			
PART NAME			
"CR2" & "AA" BATTERY HOLDER, ON TAPE			
MATERIAL			
AS NOTED			
FINISH		DRN BY	DATE
AS NOTED		NT	7.20.09
		APP'D	SCALE
		RH	X
TOLERANCES	INCH [MM]	CODE	DWG NO.
DECIMAL	± .015 [± 0.38]	C	553TR
ANGULAR	± 1°		
UNLESS OTHERWISE SPECIFIED			

MOUNTING PAD LAYOUT. REQUIRED SPACING FOR 'A' OR 'AA' BATTERIES

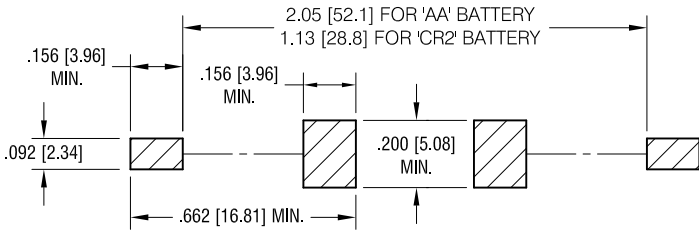

THIS DOCUMENT IS THE PROPERTY OF KEYSTONE ELECTRONICS CORP. AND SHALL NOT BE REPRODUCED, DISTRIBUTED OR USED AS A BASIS FOR MANUFACTURE WITHOUT PRIOR WRITTEN PERMISSION FROM KEYSTONE ELECTRONICS CORP.

ACTUAL SIZE

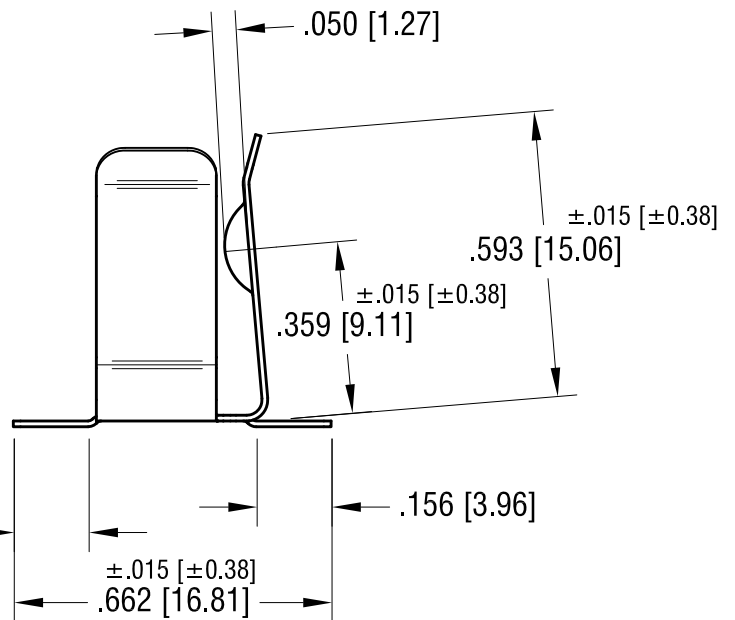
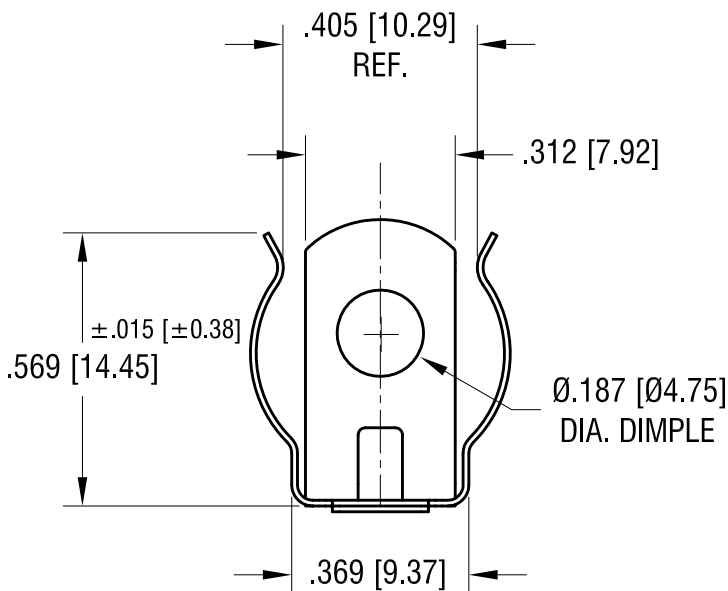
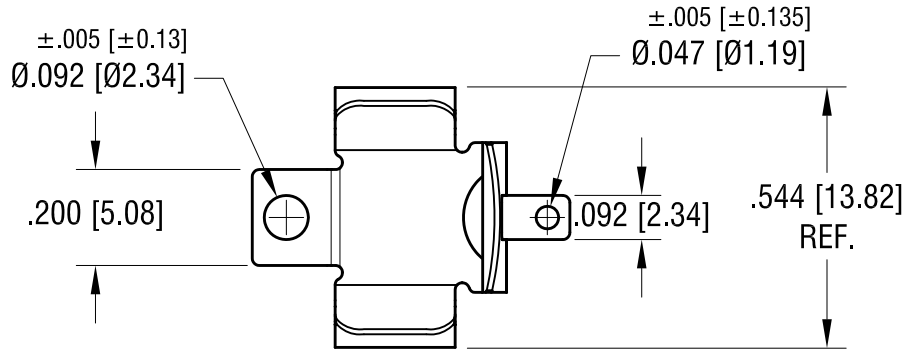

NOTE:

1. HEAT TREAT TO SPRING TEMPER.

**KEYSTONE ELECTRONICS CORP.**

www.keyelco.com • NEW HYDE PARK, NY 11040 • Tel (516) 328-7500

PART NAME

'CR2' & 'AA' BATTERY CLIP

MATERIAL

.012 [0.30] TH'K ANNEALED SPRING STEEL

FINISH

MATTE TIN PLATE

DRN BY

NT

DATE

7.20.09

APP'D

RH

SCALE

2.5X

TOLERANCES

INCH [MM]

DECIMAL

±.010 [±0.25]

ANGULAR

± 1°

UNLESS OTHERWISE SPECIFIED

CODE

C

DWG NO.

553

DATE	DESCRIPTION	REV.
1.31.18	CHANGE AS PER ECN 18-008	B
10.20.09	CHANGE AS PER ECN 09-153	A