

NOTES

- ALL DIMENSIONS ARE IN $\frac{\text{INCHES}}{[\text{MILLIMETERS}]}$
- DIMENSIONS APPEARING IN TABLE ARE AS FOLLOWS:
 - a - AS SUPPLIED
 - b - AFTER UNRESTRICTED RECOVERY
- COATING (ADHESIVE) IS OPTIONAL. AS SUPPLIED DIMENSIONS APPEARING IN TABLE ARE FOR UNCOATED PARTS. WHEN COATING IS ADDED, ENTRY DIAMETERS WILL BE REDUCED BY .06 MAX.
- MOLDING PORTS ARE OPTIONAL. WHEN -00 MODIFICATION NUMBER IS SPECIFIED MOLDING PORTS WILL BE LOCATED AS SHOWN.

REVISIONS		
LTR	DESCRIPTION	DATE
A	ECO-08-009707	04/17/2008

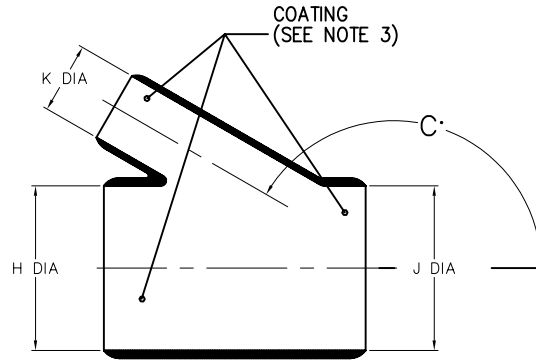

AS SUPPLIED

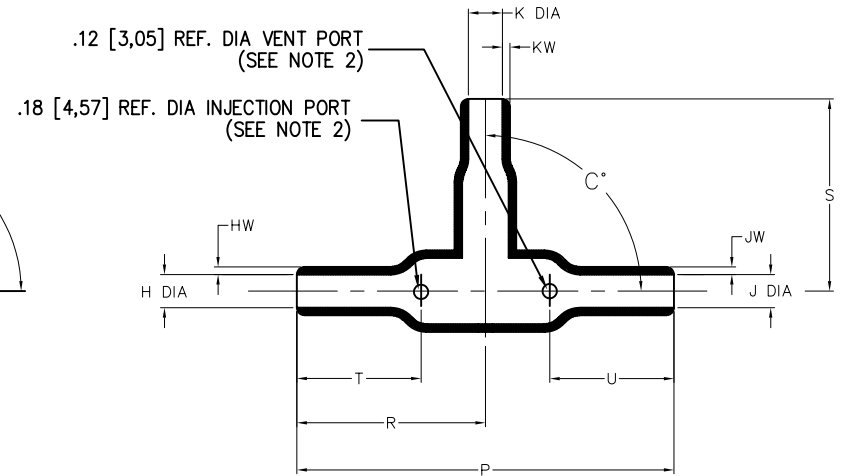

AFTER UNRESTRICTED RECOVERY

TABLE OF DIMENSIONS

PART DESCRIPTION	H & J		K		P	R	S	T	U	HW&JW	KW	C°	
	MIN	MAX	MIN	MAX	±10%	±10%	±10%	±10%	±10%	±20%	±20%	±10%	±5%
	a	b	a	b	b	b	b	b	b	b	b	a	b
322A434	$\frac{1.20}{[30,4]}$	$\frac{.60}{[15,3]}$	$\frac{.80}{[20,3]}$	$\frac{.40}{[10,2]}$	$\frac{3.25}{[82,6]}$	$\frac{1.62}{[41,1]}$	$\frac{1.50}{[38,1]}$	$\frac{1.23}{[31,2]}$	$\frac{1.23}{[31,2]}$	$\frac{.10}{[2,54]}$	$\frac{.077}{[1,96]}$	165	90

CUSTOMER DRAWING

UNLESS OTHERWISE SPECIFIED DIMENSIONS ARE INCHES. METRIC DIMENSIONS ARE IN BRACKETS.	DRAWN	DATE	 Raychem Molded Parts 305 Constitution Dr Menlo Park, CA 94025
	UNGUYEN	04/17/2008	
DECIMAL TOLERANCES .XXX ± 0.005 [0.13 mm] .XX ± 0.01 [0.25 mm] .X ± 0.1 [0.50 mm]	RPN	TITLE TRANSITION, 90 DEGREE, SIDE BREAKOUT, THINWALL	
	ANGLE TOLERANCE .X ± 1 DEG.		
SIZE B		CODE IDENT. NO. 06090	DWG. NO. 322A434
© 2008 Tyco Electronics Corporation. All rights reserved.			DO NOT SCALE THIS DRAWING
			SHEET 1 OF 2

If this document is printed it becomes uncontrolled. Check for the latest revision

4

3

2

1

COMPATIBILITY CHART

MATERIAL DASH NO.	MATERIAL DESCRIPTION	RT SPEC	COATING SLASH NO.	COATING SPEC	COATING DESCRIPTION
-3	POLYOLEFIN, SEMI-RIGID	RT-301	/42; /86	S-1017; S-1048	ADHESIVE
-4	POLYOLEFIN, FLEXIBLE	RT-1304	/164, /86	S-1017; S-1048	ADHESIVE
-5	ELASTOMER, FLEXIBLE	RT-501	/42,	S-1017	ADHESIVE
-6	SILICONE	RT-602	N/A		
-12	FLUOROELASTOMER	RT-1312	N/A		
-25	ELASTOMER, FLUID RESISTANT	RT-1325	/86	S-1048	ADHESIVE
-100	POLYOLEFIN, SEMI-FLEXIBLE ZEROHAL	RT-1323	/86; /180	S-1048; S-1030	ADHESIVE

ORDERING INFORMATION

BASE PART NUMBER 322A434 -XX -XX /XX
 MATERIAL DASH NUMBER (SEE COMPATIBILITY CHART)
 MODIFICATION NUMBER
 ADHESIVE SLASH NUMBER (IF NECESSARY, SEE COMPATIBILITY CHART)

CUSTOMER DRAWING

If this document is printed it becomes uncontrolled. Check for the latest revision

SIZE	DWG. NO.	REV	DWG. NO.	
B	06090	A		322A434
DO NOT SCALE THIS DRAWING			SHEET 2 OF 2	

4

3

2

1