

MATERIAL

High-resilience polypropylene based (PP) technopolymer, coated with thermoplastic elastomer (TPE) "soft-touch" chemically bonded, hardness 70 Shore A. The coating material is produced from FDA compliant raw material (FDA CFR.21 and EU 10/2011), black colour, matte finish.

COLOURED CENTRE CAP

Polypropylene based (PP) technopolymer, in the six standard colours, matte finish.

On request and for sufficient quantities, it can be supplied in other colours or with customised graphic symbols, marks or writings.

STANDARD EXECUTIONS

- **VCT-B-SOFT:** brass boss, threaded blind hole.
- **VCT-p-SOFT:** zinc-plated steel threaded stud with chamfered flat end as in UNI 947 : ISO 4753 (see Technical data pag. A-10).



ELESA Original design

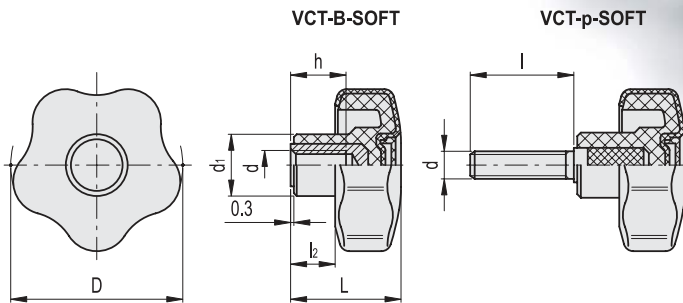

* Complete with colour index, example: 169894-C2 VCT.43 B-M8-SOFT-C2

- C9** RAL9005
- C2** RAL2004
- C3** RAL7035
- C4** RAL1021
- C5** RAL5024
- C6** RAL3000
- C17** RAL6017

VCT-B-SOFT

METRIC

Code	Description	D	d6H	L	d1	l2	h	C#	⚖
169892-*	VCT.43 B-M6-SOFT-*	43	M6	29	17	11	12	15	22
169894-*	VCT.43 B-M8-SOFT-*	43	M8	29	17	11	13	18	20
169952-*	VCT.53 B-M8-SOFT-*	53	M8	34	19	13	15	25	33
169954-*	VCT.53 B-M10-SOFT-*	53	M10	34	19	13	17	27	36
170013-*	VCT.66 B-M10-SOFT-*	66	M10	38.5	21.5	15.5	17	50	44
170015-*	VCT.66 B-M12-SOFT-*	66	M12	38.5	21.5	15.5	17	50	42
170062-*	VCT.77 B-M12-SOFT-*	77	M12	46	26	21	20	60	51

"Max limit Tightening torque" means the max torque value at which the metal insert, in normal conditions of use, is perfectly and strongly anchored to the plastic material.

Conversion Table	
1 mm = 0,039 inch	
D	
mm	inch
43	1.69
53	2.09
66	2.60
77	3.03

VCT-p-SOFT

METRIC

Code	Description	D	d6g	L	d1	l	l2	C#	⚖
169901-*	VCT.43 p-M6x16-SOFT-*	43	M6	29	17	16	11	13	18
169902-*	VCT.43 p-M6x20-SOFT-*	43	M6	29	17	20	11	13	19
169903-*	VCT.43 p-M6x25-SOFT-*	43	M6	29	17	25	11	13	20
169905-*	VCT.43 p-M6x30-SOFT-*	43	M6	29	17	30	11	13	21
169911-*	VCT.43 p-M8x16-SOFT-*	43	M8	29	17	16	11	16	19
169912-*	VCT.43 p-M8x20-SOFT-*	43	M8	29	17	20	11	16	20
169913-*	VCT.43 p-M8x25-SOFT-*	43	M8	29	17	25	11	16	22
169915-*	VCT.43 p-M8x30-SOFT-*	43	M8	29	17	30	11	16	24
169916-*	VCT.43 p-M8x40-SOFT-*	43	M8	29	17	40	11	16	26
169961-*	VCT.53 p-M8x16-SOFT-*	53	M8	34	19	16	13	16	33
169963-*	VCT.53 p-M8x20-SOFT-*	53	M8	34	19	20	13	16	34
169965-*	VCT.53 p-M8x30-SOFT-*	53	M8	34	19	30	13	16	36
169967-*	VCT.53 p-M8x40-SOFT-*	53	M8	34	19	40	13	16	38
169971-*	VCT.53 p-M10x20-SOFT-*	53	M10	34	19	20	13	23	36
169973-*	VCT.53 p-M10x30-SOFT-*	53	M10	34	19	30	13	23	40
169975-*	VCT.53 p-M10x40-SOFT-*	53	M10	34	19	40	13	23	44
169977-*	VCT.53 p-M10x50-SOFT-*	53	M10	34	19	50	13	23	48
170021-*	VCT.66 p-M10x20-SOFT-*	66	M10	38.5	21.5	20	15.5	37	46
170023-*	VCT.66 p-M10x30-SOFT-*	66	M10	38.5	21.5	30	15.5	37	49
170025-*	VCT.66 p-M10x40-SOFT-*	66	M10	38.5	21.5	40	15.5	37	52
170027-*	VCT.66 p-M10x50-SOFT-*	66	M10	38.5	21.5	50	15.5	37	56
170033-*	VCT.66 p-M12x30-SOFT-*	66	M12	38.5	21.5	30	15.5	46	52
170035-*	VCT.66 p-M12x40-SOFT-*	66	M12	38.5	21.5	40	15.5	46	56
170037-*	VCT.66 p-M12x50-SOFT-*	66	M12	38.5	21.5	50	15.5	46	60
170083-*	VCT.77 p-M12x30-SOFT-*	77	M12	46	26	30	21	68	53
170085-*	VCT.77 p-M12x40-SOFT-*	77	M12	46	26	40	21	68	57
170087-*	VCT.77 p-M12x50-SOFT-*	77	M12	46	26	50	21	68	62

"Max limit Tightening torque" means the max torque value at which the metal insert, in normal conditions of use, is perfectly and strongly anchored to the plastic material.

