

### specifications

Net-Verse™ Cabinets shall consist of a welded and assembled steel frame construction available in 600mm (23.6") and 800mm (31.5") widths, 1000mm (39.4") and 1200mm (47.3") depths, and 42 RU, 45 RU, and 48 RU heights. Cabinet shall include curved perforated front single hinge doors with 69% air flow rate and split rear perforated doors. Cabinet shall have two horizontal locking side panels on each side or optional as an accessory. The cabinet shall have fully adjustable front and rear equipment rails. 800mm wide cabinet comes with provisions for front or rear cable management fingers and brackets that are available as an accessory. 800mm wide cabinets shall have vertical blanking panel with (4) 1 RU vertical pass throughs and cover plates. The top of cabinet includes brush cable entry points to prevent air leakage. Cabinet shall have optional bottom panels with brush cable entry points and cover plates for effective air sealing. Cabinet shall have two full height PDU/cable management brackets, one on each side. The entire cabinet shall be fully electrically bonded, including equipment rails, doors, and side panels. The cabinet comes equipped with the necessary brackets and hardware to gang adjoining Net-Verse™ Cabinets. Cabinet shall have 1,500kg (3,300 lbs.) static load rating and 500kg (1,100 lbs.) rolling load rating.



### technical information

<b>Dimensions:</b>	600mm W (23.6") x 1000mm D (39.4") x 2045mm H (80.5")
	600mm W (23.6") x 1000mm D (39.4") x 2178mm H (85.8")
	600mm W (23.6") x 1200mm D (47.3") x 2045mm H (80.5")
	600mm W (23.6") x 1200mm D (47.3") x 2178mm H (85.8")
	600mm W (23.6") x 1000mm D (39.4") x 2311mm H (91.1")
	600mm W (23.6") x 1200mm D (47.3") x 2311mm H (91.1")
	800mm W (31.5") x 1000mm D (39.4") x 2045mm H (80.5")
	800mm W (31.5") x 1000mm D (39.4") x 2178mm H (85.8")
	800mm W (31.5") x 1200mm D (47.3") x 2045mm H (80.5")
	800mm W (31.5") x 1200mm D (47.3") x 2178mm H (85.8")
800mm W (31.5") x 1000mm D (39.4") x 2311mm H (91.1")	
800mm W (31.5") x 1200mm D (47.3") x 2311mm H (91.1")	
<b>Material:</b>	Steel with durable black or white powder coat finish
<b>Compliance:</b>	EIA-310-E TIA/EIA-942
<b>Packaging:</b>	Cabinet ships assembled, one per pallet

Net-Verse™ Cabinets

		800mm Width	600mm Width	
<b>With Side Panels</b>	42 RU	DN8212*	DN6212*	<b>1000mm Depth</b>
	45 RU	DN8512*	DN6512*	
	48 RU	DN8812*	DN6812*	
	42 RU	DN8222*	DN6222*	<b>1200mm Depth</b>
	45 RU	DN8522*	DN6522*	
	48 RU	DN8822*	DN6822*	
<b>Without Side Panels</b>	42 RU	DN8219*	DN6219*	<b>1000mm Depth</b>
	45 RU	DN8519*	DN6519*	
	48 RU	DN8819*	DN6819*	
	42 RU	DN8229*	DN6229*	<b>1200mm Depth</b>
	45 RU	DN8529*	DN6529*	
	48 RU	DN8829*	DN6829*	

\*Available in Black (B) or White (W)

### key features and benefits

<b>Doors</b>	Curved perforated front single hinge doors with 69% air flow rate with two point locking system; perforated split hinge rear doors with three point locking system
<b>Equipment rails</b>	Fully adjustable equipment rails with RU markings to ensure correct location of IT equipment
<b>Universal PDU brackets</b>	Full height PDU brackets with provisions for securing and bundling cables
<b>Horizontally split locking side panels</b>	Provide easy secured access to installed equipment
<b>Modular cable management fingers (Optional, for 800mm only)</b>	Provides bend radius control for each rack unit and can be positioned where required on cabinet posts for cable protection for increased network availability; provides design flexibility, scalability, and improved aesthetics for easier moves, adds, and changes
<b>Durable coating</b>	Cabinets are powder coated in a durable, low maintenance paint in black (RAL 9005) or white (RAL 9003)

### applications

Net-Verse™ Cabinets are the preferred choice for applications that require maximum flexibility and the capacity to manage high cable density in data center, enterprise or co-location deployment. Net-Verse™ Cabinets are also compatible with Panduit cable management accessories and the Net-Contain™ Universal Aisle Containment System.

<b>Front Door</b>	
42 RU x 600mm	D62FD*
45 RU x 600mm	D65FD*
48 RU x 600mm	D68FD*
42 RU x 800mm	D82FD*
45 RU x 800mm	D85FD*
48 RU x 800mm	D88FD*
<b>Rear Door</b>	
42 RU x 600mm	D62RD*
45 RU x 600mm	D65RD*
48 RU x 600mm	D68RD*
42 RU x 800mm	D82RD*
45 RU x 800mm	D85RD*
48 RU x 800mm	D88RD*
<b>Side Panels</b>	
42 RU x 1000mm:	D21SP*
42 RU x 1200mm:	D22SP*
45 RU x 1000mm:	D51SP*
45 RU x 1200mm:	D52SP*
48 RU x 1000mm:	D81SP*
48 RU x 1200mm:	D82SP*
<b>Vertical Blanking Panels</b>	
600mm:	D6VBP*
800mm:	D8VBP*
<b>Bottom Cover Plates</b>	
600mm wide x 1000mm depth:	D61BCP*
600mm wide x 1200mm depth:	D62BCP*
800mm wide x 1000mm depth:	D81BCP*
800mm wide x 1200mm depth:	D82BCP*
<b>Tapped Equipment Rails</b>	
42 RU:	D2ERT*
45 RU:	D5ERT*
48 RU:	D8ERT*
<b>Cage Nut Equipment Rails</b>	
42 RU:	D2ER*
45 RU:	D5ER*
48 RU:	D8ER*
<b>PDU/Cable Management Bracket</b>	
42 RU:	D2CM*
45 RU:	D5CM*
48 RU:	D8CM*
<b>Accessories Cable Management Fingers with Mounting Brackets for 800mm Wide Cabinet</b>	
42 RU:	D12FB*
45 RU:	D15FB*
48 RU:	D18FB*

\*Available in Black (B) or White (W)

# Net-Verse™ Cabinets

## Net-Verse™ Cabinet 600mm W x 42/45/48 RU x 1000mm/1200mm D

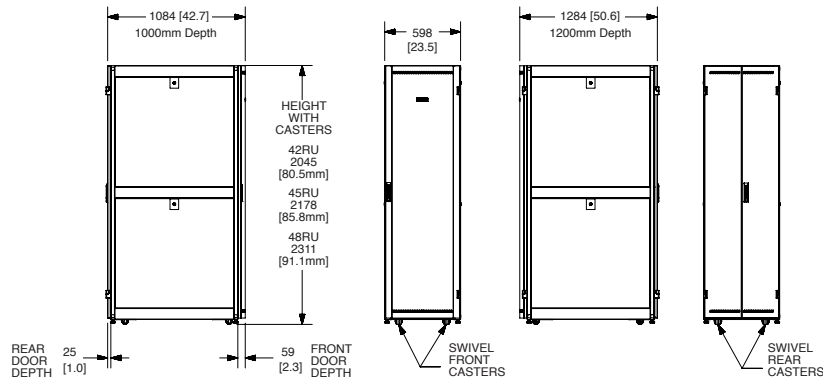
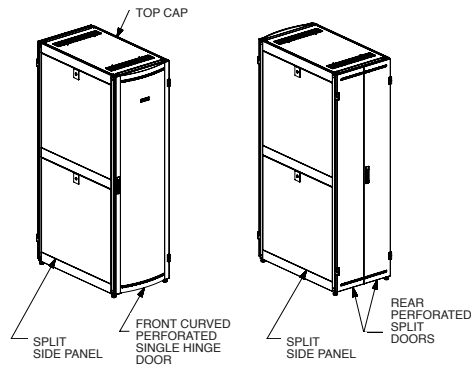

## Net-Verse™ Cabinet 800mm W x 42/45/48 RU x 1000mm/1200mm D

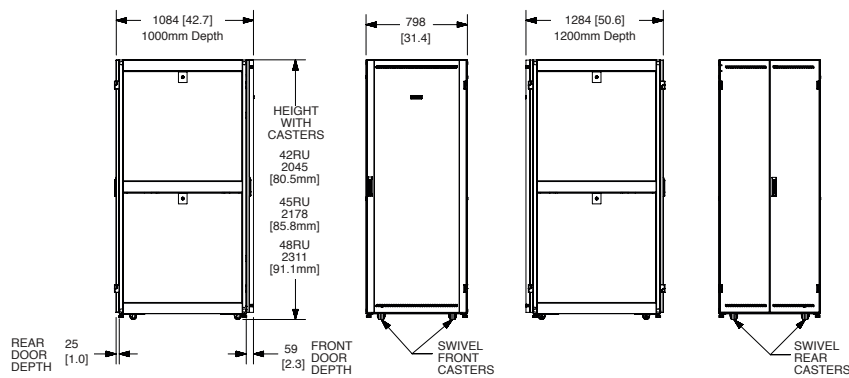
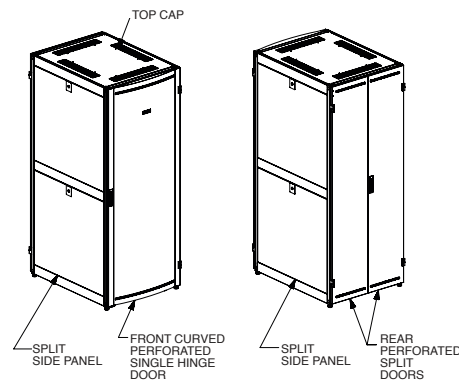

Dimensions are in metric. [Dimensions in brackets are inches].

### WORLDWIDE SUBSIDIARIES AND SALES OFFICES

PANDUIT US/CANADA  
Phone: 800.777.3300

PANDUIT EUROPE LTD.  
London, UK  
Phone: 44.20.8601.7200

PANDUIT SINGAPORE PTE. LTD.  
Republic of Singapore  
Phone: 65.6305.7575

PANDUIT JAPAN  
Tokyo, Japan  
Phone: 81.3.6863.6000

PANDUIT LATIN AMERICA  
Guadalajara, Mexico  
Phone: 52.33.3777.6000

PANDUIT AUSTRALIA PTY. LTD.  
Victoria, Australia  
Phone: 61.3.9794.9020

For a copy of Panduit product warranties, log on to [www.panduit.com/warranty](http://www.panduit.com/warranty)

# PANDUIT®

For more information  
Visit us at [www.panduit.com](http://www.panduit.com)

©2019 Panduit Corp.  
ALL RIGHTS RESERVED.  
RKSP183--WW-ENG  
6/2019