



UMFT233HPEV Evaluation Module Datasheet

Version 1.0

Issue Date: 24-11-2021

Use of FTDI devices in life support and/or safety applications is entirely at the user's risk, and the user agrees to defend, indemnify and hold FTDI harmless from any and all damages, claims, suits or expense resulting from such use.

Future Technology Devices International Limited (FTDI)

Unit 1, 2 Seaward Place, Glasgow G41 1HH, United Kingdom

Tel.: +44 (0) 141 429 2777 Fax: + 44 (0) 141 429 2758

Web Site: <https://ftdichip.com>

Copyright © Future Technology Devices International Limited

Contents

1 Introduction	3
1.1 EVB Features	3
2 Typical Applications.....	4
2.1 Driver Support.....	4
2.2 USB Bridge Features.....	4
3 Electrical Details.....	5
3.1 Power.....	6
3.2 GPIO	7
3.3 Connectors	8
3.4 Remote Wakeup	9
3.5 Schematics	10
4 Power Delivery Functional Configuration.....	15
4.1 Pass-through.....	15
4.2 Dual Role.....	15
4.3 Sink.....	17
5 Mechanical Details.....	18
6 Contact Information	19
Appendix A – References	20
Document References	20
Acronyms and Abbreviations.....	20
Appendix B – List of Tables and Figures.....	21
List of Tables.....	21
List of Figures	21
Appendix C – Revision History	22

1 Introduction

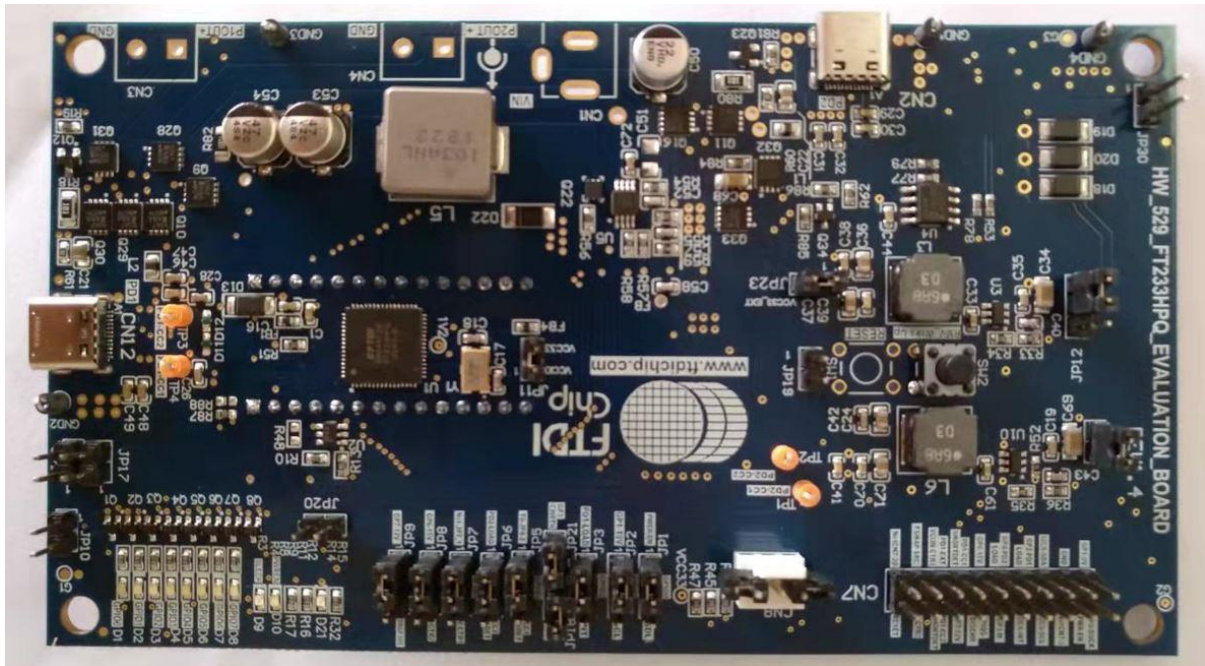

Figure 1 - UMFT233HPEV Evaluation Module Board

The module has 138.5mm x 77mm dimensions, with a pair of Type-C power delivery ports incorporated into it. The first of these ports is capable of sink (receiving power) and source (providing power) roles. The second port serves only as a sink port. Both of these ports are able to support the 5V, 9V, 12V, 15V and 20V power delivery object (PDO) profiles - as defined in revision 3.0 of the USB Power Delivery specification. These profiles may be configured via an external EEPROM memory, with LED indicators signifying which PDO profile is in use.

While the first port offers USB data transmission plus power delivery, the second port only has power delivery capabilities. A power pass-through function has also been included, with the input power on the second port being passed to the first port. External control of power delivery policy can be achieved using the on-board I2C interface and the GPIO pins. GPIO pins allow adjustment of the voltage regulator and the load switch.

1.1 EVB Features

- Two Type-C™ USB PD ports with,
 - PD1 which is an initial sink port that supports power role swap and USB Data which is USB 2.0 compliant.
 - PD2 which is a sink-only port.
- Supports the self-powered and bus-powered operation.
- Configurable Jumper options to enable/disable pass-through circuit or voltage-dc regulator.
- Supports external control of power delivery policy using the on-board I2C and GPIO pins. Configurable jumper options to connect I2C.
- LED indicators for every GPIO pin and PWREN#, SUSPEND# signals and System Power.
- Test points for all power supply voltages, core voltages, PD VBUS voltages and CC Voltages.
- External EEPROM for configurable options.

2 Typical Applications

- Rapid USB integration into existing electronic systems
- Prototyping platform for USB interface on new system
- USB Bridge with Type-C/PD3.0 (chargers and devices).
- Up to 60W power application delivery via USB PD and/or Type-C port.
- USB to multi-port JTAG, SPI and I2C interfaces
- USB to multi-port asynchronous serial interfaces

2.1 Driver Support

The FT233HP requires USB drivers (listed below), available free from <https://www.ftdichip.com>, which are used to make the FT233HP appear as a virtual COM port (VCP). This allows the user to communicate with the USB interface via a standard PC serial emulation port (for example TTY). Another FTDI USB driver, the D2XX driver, can also be used with application software to directly access the FT233HP through a DLL.

Royalty free VIRTUAL COM PORT (VCP) DRIVERS for...

- Windows 10 32,64-bit
- Windows 8/8.1 32,64-bit
- Windows 7 32,64-bit
- Windows Server 2008 and server 2012 R2
- Mac OS
- Linux 2.4 and greater

Royalty free D2XX Direct Drivers (USB Drivers + DLL S/W Interface)

- Windows 10 32,64-bit
- Windows 8/8.1 32,64-bit
- Windows 7 32,64-bit
- Windows Server 2008 and server 2012 R2
- Mac OS
- Linux 2.4 and greater
- Android(J2xx)

For driver installation, please refer to the installation guides on our website: <https://ftdichip.com/document/installation-guides/>

2.2 USB Bridge Features

For information on USB Bridge features, please refer to [FT233HP Datasheet](#).

3 Electrical Details

The UMFT233HPEV Evaluation Board is a 138.5mm by 77mm 4-layered printed circuit board.

The key features are labelled in Figure 2 and Figure 3. Refer to Table 1 for the label description.

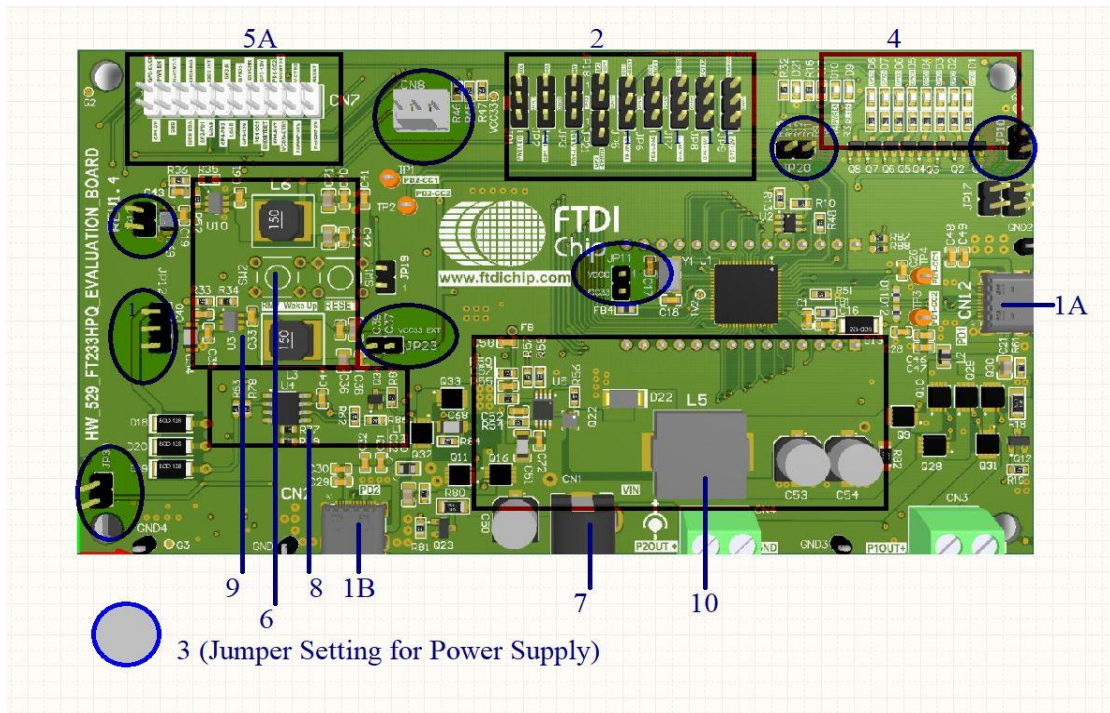

Figure 2 - UMFT233HPEV Evaluation Module Board – Top View

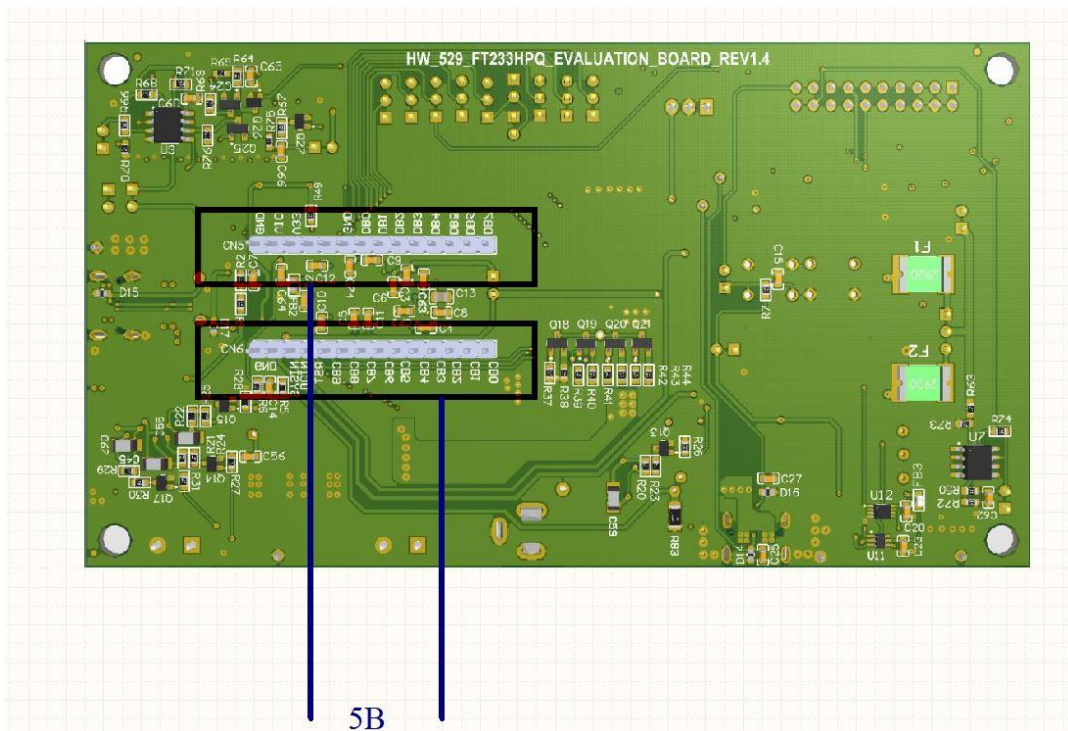

Figure 3 - UMFT233HPEV Evaluation Module Board – Bottom View

Label	Description
1A	PD Port 1 for sink or dual role
1B	PD Port 2 for sink only
2	Jumper Setting for GPIOs control of power profile
3	Jumper Setting for Power Supply
4	LEDs indication for the USB and GPIO control of power profile
5A	Functional interface connector for Ext MCU
5B	Connector for single channel multipurpose interface
6	Push Button switch and jumper setting for remote wakeup
7	DC power socket (Not mounted)
8	5V detector circuit
9	DC-DC converters for FT233HPQ and other circuits
10	Voltage Regulator for PD source supply

Table 1 - UMFT233HPEV Evaluation Board – Electrical Details – Label & Description

3.1 Power

The UMFT233HPEV Evaluation board provides two power sources:

- a) 3.46V for FT233HPQ and most other circuits on the board.
- b) 3.3V for LED drivers

The reason why 3.46V is needed for FT233HPQ is due to the adding of schottky diode between Vcc_PD/PD1_Vconn and VCC33 to prevent CC leakage during initial attach when the chip is not yet fully powered up. Refer to Section 4.15.5 of FT233HPQ datasheet for more detail.

Both power sources are derived from bus power via PD port 1 or port 2. There is also provision of DC plug footprint as an option to obtain power from external power supply or DC power adaptor. Table 2 shows the jumper pin detail for power configuration.

Jumper pin	Name	Description	Default jumper setting
JP11-2	VCC33	3.46V supply	JP11-1 short to JP11-2
JP11-1	VCCIO	Power to the VCCIO of FT233HPQ	
JP12-1	PD1_PD2_DCIN_VBUS	sources from PD1_Vbus or PD2_Vbus or DC power adaptor	JP12-1 short to JP12-2
JP12-2	V_SYS_INPUT	Power input to the 3.46V DC to DC converter (U3)	
JP12-3	V_SYS_INPUT_EXT	Sources from external power supply	
JP13-1	V_SYS_INPUT	Power input to the 3.3V DC to DC converter (U10)	JP13-1 short to JP13-2
JP13-2	VIN	Power input to the 3.3V DC to DC converter (U10)	
JP23-1	V3.3	Output from the 3.46V DC to DC converter (U3)	JP23-1 short to JP23-2
JP23-2	VCC33	3.46V supply	
JP10-1	VCC33	3.46V supply	Open
JP10-2	-	Power input to comparator U9	
JP20-1	-	Power input to the PD1 and PD2 external Vconn control circuit	Open
JP20-2	VCC_3V3	3.3V supply	
JP30-1	VCC33	3.46V supply	Open
JP30-2	-	Power input to comparator U7	
CN8-1	VCC_3V3	VCC_3V3 pin	Open
CN8-2	GND	GND pin	Open
CN8-3	VCC33	VCC33 pin	Open

Table 2 - Jumper Pin Details for Power

USB Bus-Powered:

The power configuration for power deriving from the PD ports should be as follows:

JP12 pin1 should be connected to JP12 pin2 –This is to route the power from either PD1 or PD2 to the U3 and U10 DC to DC converter. Refer to Figure 5 in Section [Schematics](#).

JP11 pin 1 should be connected to JP11 pin2 – This is to provide power to VCCIO of FT233HPQ. Refer to Figure 6 in Section [Schematics](#).

USB Self-Powered:

The power configuration for power deriving from the external DC power should be as follows:

JP12 pin1 should be connected to JP12 pin2 –This is to route the power from DC jack CN1 to the U3 and U10 DC to DC converter. Refer to Figure 5 in Section [Schematics](#).

JP11 pin 1 should be connected to JP11 pin2 – This is to provide power to VCCIO of FT233HPQ. Refer to Figure 6 in in Section [Schematics](#).

Precaution: Take note that PD charger cannot be plugged into the PD2 port for usage during Self-powered mode.

3.2 GPIO

The GPIOs from FT233HPQ are used to control the load switch as well as the voltage regulator on the board in accordance to the PD power profile used during PD negotiation between the charger and the charging device. It can also be allowed external MCU access through an I2C slave interface with jumper setting. Table 3 shows the overview on the jumper configuration of GPIOs.

Jumper Pin	Name	Description	Default jumper setting
JP1-1	GPIO0-BuckPWR-EN	To enable/disable the voltage regulator (U5) and the load switch from voltage to PD1_Vbus (Q9,Q10,Q15)	JP1-1 short to JP1-2
JP1-2	GPIO0	Output from FT233HPQ	
JP1-3	I2CS-SDA	I2C data (slave)	
JP2-1	GPIO1-9V	To control the resistor divider on the voltage regulator for 9V generation	JP2-1 short to JP2-2
JP2-2	GPIO1	Output from FT233HPQ	
JP2-3	I2CS-SCL	I2C clock (slave)	
JP3-1	GPIO2-PD1-LOAD	To control the PD1 load switch to route the Vbus from PD1 to the CN3 for monitoring.	JP3-1 short to JP3-2
JP3-2	GPIO2	Output from FT233HPQ	
JP3-3	I2CS-INT	I2C Interrupt (slave)	
JP5-1	GPIO3-M	To JP18 and JP21	JP5-1 short to JP5-2
JP5-2	GPIO3	Output from FT233HPQ	
JP5-3	PD1_CC1_SHORTDET	Output from external Vconn short detection circuit	
JP6-1	GPIO4_PD2-LOAD	To control the PD2 load switch to route the Vbus from PD2 to the voltage regulator and pass-through path	JP6-1 short to JP6-2
JP6-2	GPIO4	Output from FT233HPQ	
JP6-3	PD1_CC2_SHORTDET	Output from external Vconn short detection circuit	
JP7-1	GPIO5-DISCHR	To control the discharge circuit on	JP7-1 short to

		PD1_Vbus	
JP7-2	GPIO5	Output from FT233HPQ	JP7-2
JP7-3	PD1_EXT_VCON_CTRL1	To enable the external Vconn power for PD1 CC1	
JP8-1	GPIO6-15V	To control the resistor divider on the voltage regulator for 15V generation	JP8-1 short to JP8-2
JP8-2	GPIO6	Output from FT233HPQ	
JP8-3	PD1_EXT_VCON_CTRL2	To enable the external Vconn power for PD1 CC2	
JP9-1	GPIO7-12V	To control the resistor divider on the voltage regulator for 12V generation	JP9-1 short to JP9-2
JP9-2	GPIO7	Output from FT233HPQ	
JP9-3	FSWAP_SRC	Output from Fast Role Swap circuit	
JP18-1	GPIO3-CHRTH	To control the load switch to route the negotiated power from PD2 to PD1	JP18-1 short to JP18-2
JP18-2	GPIO3-M	-	
JP19-1	RESET#	Active low reset to FT233HPQ	Open
JP19-2	RESET	To connector CN7-19	
JP21-1	GPIO3-20V	To control the resistor divider on the voltage regulator for 20V generation	Open
JP21-2	GPIO3-M	-	

Table 3 - Jumper Configuration Details for GPIO

3.3 Connectors

Connectors CN5, CN6 and CN7 for functional interface are detailed in Table 4, Table 5 and Table 6.

Connector Pin	Name (FT233HPQ)	Description
CN5-1	GND	Ground
CN5-2	VCCIO	To power FT233HPQ VCCIO from external source, remove JP11
CN5-3	VCC33	To power FT233HPQ
CN5-4	PU2	Pull up resistor pin connection 1. Connect to Vbus in a self-powered configuration.
CN5-5	PU1	Pull up resistor pin connection 2. Connect to RST# in a self-powered configuration.
CN5-6	GND	Ground
CN5-7	ADBUS0	FT233HPQ ADBUS0 pin
CN5-8	ADBUS1	FT233HPQ ADBUS1 pin
CN5-9	ADBUS2	FT233HPQ ADBUS2 pin
CN5-10	ADBUS3	FT233HPQ ADBUS3 pin
CN5-11	ADBUS4	FT233HPQ ADBUS4 pin
CN5-12	ADBUS5	FT233HPQ ADBUS5 pin
CN5-13	ADBUS6	FT233HPQ ADBUS6 pin
CN5-14	ADBUS7	FT233HPQ ADBUS7 pin

Table 4 - Connector Pin Details of CN5

Connector Pin	Name (FT233HPQ)	Description
CN6-1	GND	Ground
CN6-2	V_SYS_INPUT_EXT_1	External DC
CN6-3	PD1_PD2_DCIN_VBUS_1	Power from PD1/PD2/ext DC
CN6-4	RESET#	FT233HPQ RESET# pin
CN6-5	ACBUS9	FT233HPQ ACBUS9 pin
CN6-6	ACBUS8	FT233HPQ ACBUS8 pin
CN6-7	ACBUS7	FT233HPQ ACBUS7 pin

CN6-8	ACBUS6	FT233HPQ ACBUS6 pin
CN6-9	ACBUS5	FT233HPQ ACBUS5 pin
CN6-10	ACBUS4	FT233HPQ ACBUS4 pin
CN6-11	ACBUS3	FT233HPQ ACBUS3 pin
CN6-12	ACBUS2	FT233HPQ ACBUS2 pin
CN6-13	ACBUS1	FT233HPQ ACBUS1 pin
CN6-14	ACBUS0	FT233HPQ ACBUS0 pin

Table 5 - Connector Pin Details of CN6

CN7 connector pin detail is shown in Table 6. This can be either used for debugging or as an interface to an external MCU.

Connector Pin	Name	Description
CN7-1	GPIO0-BUCKPWR-EN	To enable/disable the voltage regulator (U5) and the load switch from voltage to PD1_Vbus (Q9,Q10,Q15)
CN7-2	GPIO1-9V	To control the resistor divider on the voltage regulator for 9V generation
CN7-3	N/A	-
CN7-4	GND	Ground
CN7-5	I2CS-SCL	I2C clock from external MCU
CN7-6	I2CS-SDA	I2C data from external MCU
CN7-7	I2CS-INT	I2C Interrupt from external MCU
CN7-8	GPIO2-PD1-LOAD	To control the PD1 load switch
CN7-9	GPIO3-M	To control the load switch for the pass-through path and resistor divider on the voltage regulator for 20V
CN7-10	GPIO4-PD2-LOAD	To control the PD2 load switch
CN7-11	GPIO5-DISCHR	To control discharge circuit for PD1_VBUS
CN7-12	GPIO6-15V	To control the resistor divider on the voltage regulator for 15V generation
CN7-13	GPIO7-12V	To control the resistor divider on the voltage regulator for 12V generation
CN7-14	PD1_CC1_SHORTDET	Output from external Vconn short detection circuit
CN7-15	PD1_CC2_SHORTDET	Output from external Vconn short detection circuit
CN7-16	PD1_EXT_VCON_CTRL1	To enable the external Vconn power for PD1 CC1
CN7-17	PD1_EXT_VCON_CTRL2	To enable the external Vconn power for PD1 CC2
CN7-18	FSWAP_SRC	Output from Fast Role Swap circuit
CN7-19	RESET	To the reset pin of FT233HPQ
CN7-20	N/A	-

Table 6 - Connector Pin Details of Ext MCU (CN7)

PRECAUTION: Do not plug in any external MCU module to CN7 if operating in internal MCU mode.

3.4 Remote Wakeup

Remote wakeup is achieved by issuing high to low pulse to the following pin of channel A interface of FT233HPQ through the Push Button switch (SW2). See Figure 4.

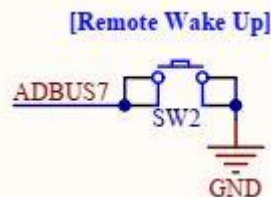
Figure 4 - Remote Wakeup Diagram

3.5 Schematics

Figure 5 to Figure 10 shows the various elements of the schematics.

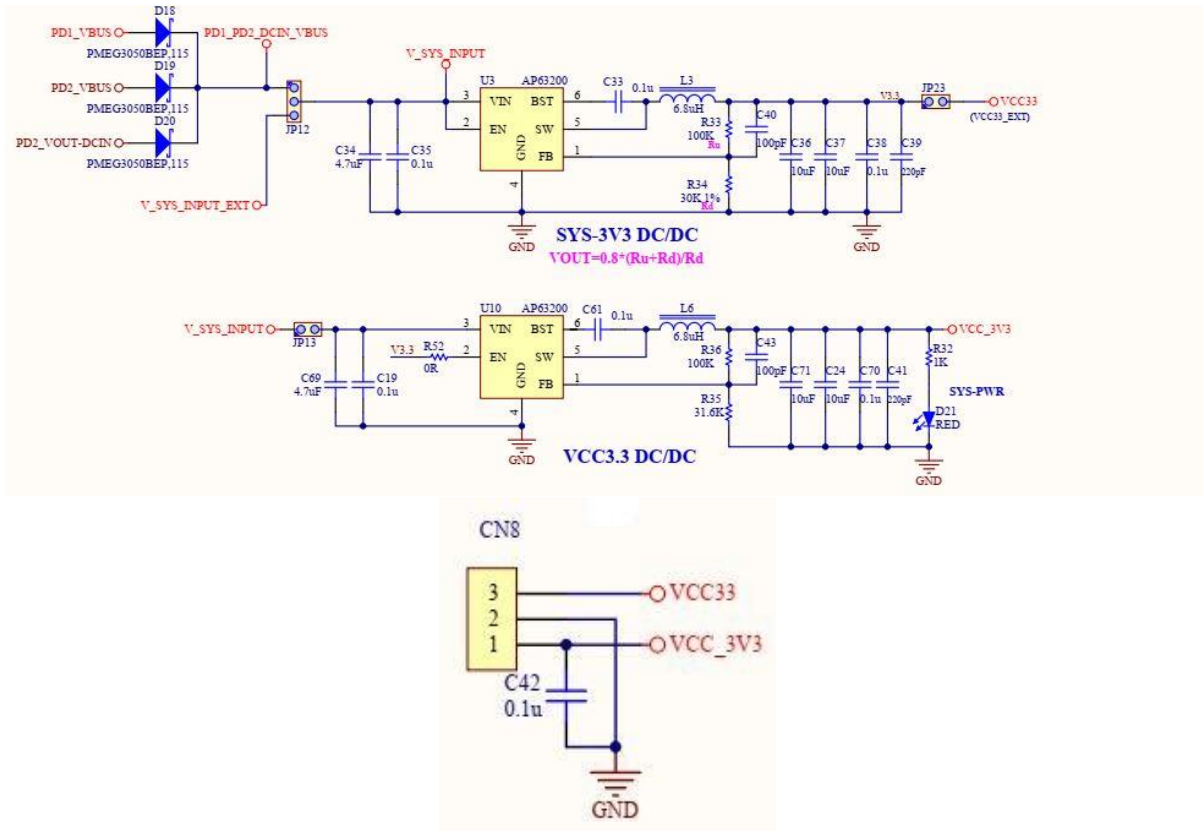

Figure 5 - DC to DC Converter for 3.46V and 3.3V from Vbus or External Power Supply

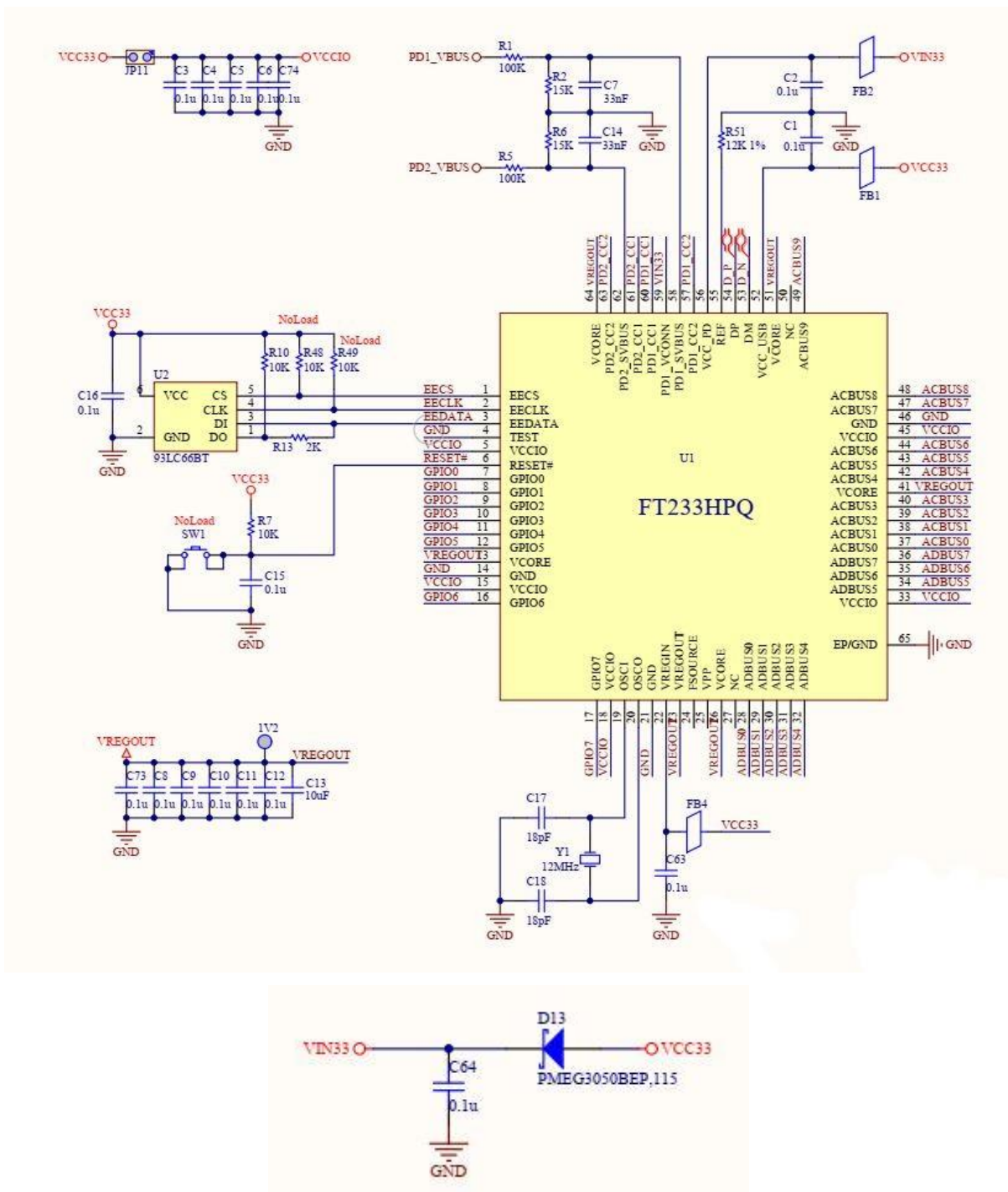

Figure 6 - FT233HPQ IC

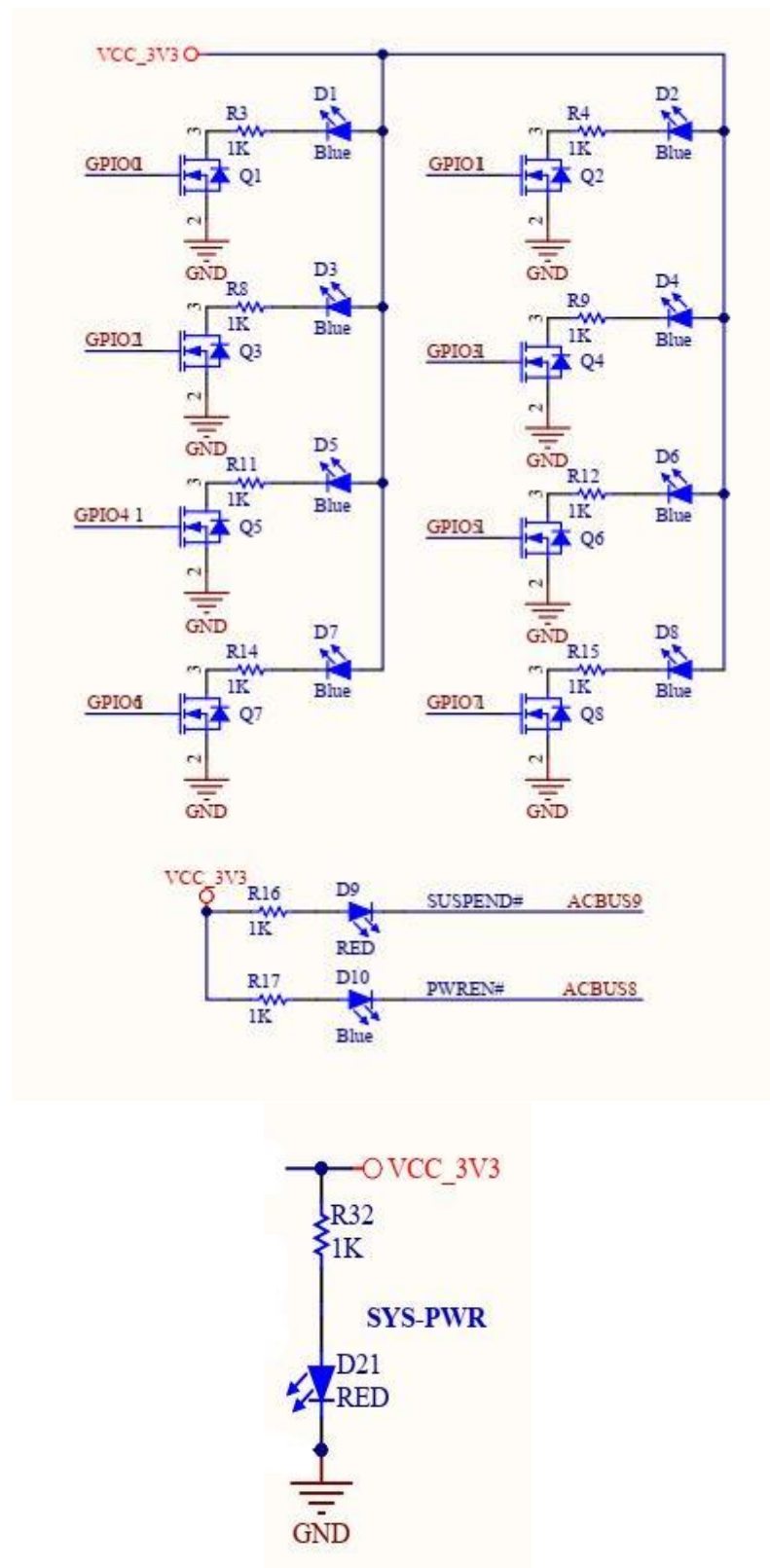

Figure 7 - LED Driver Circuit for Power, GPIO and USB Activity

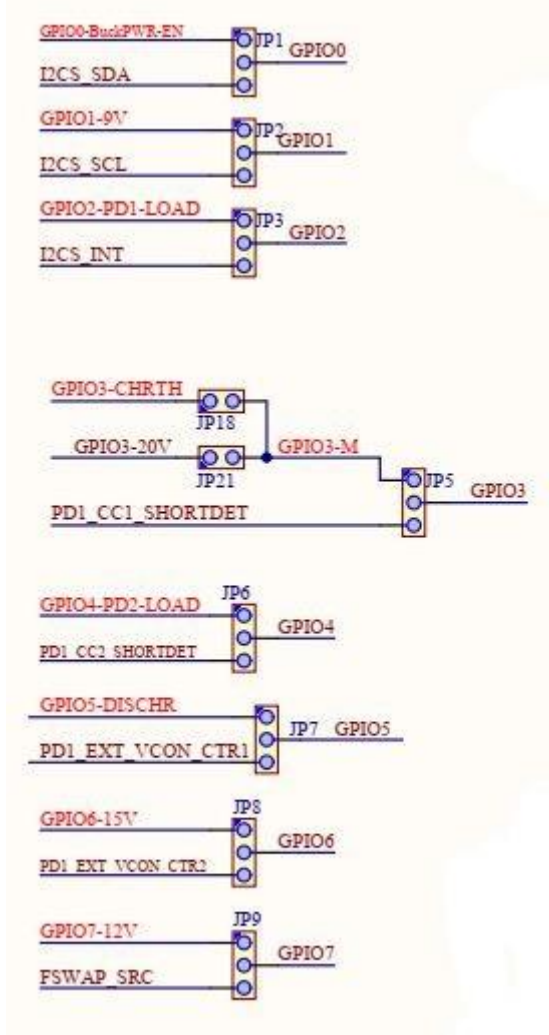
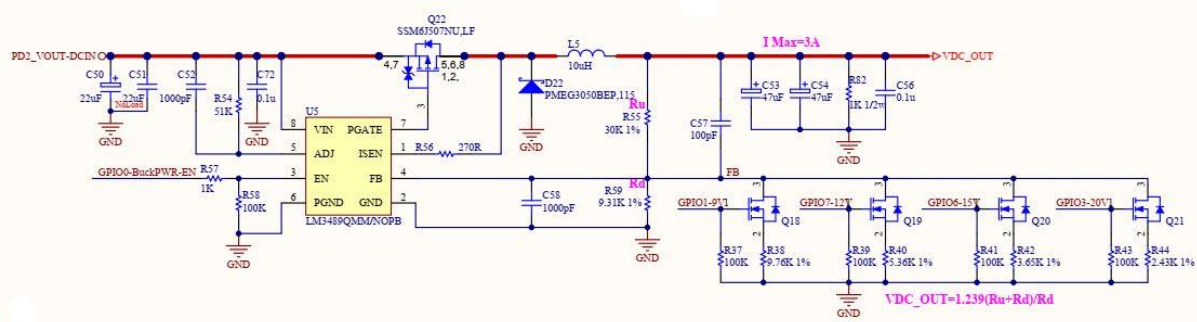

Figure 8 - Voltage Regulator for PD Profile Configurable with GPIOs

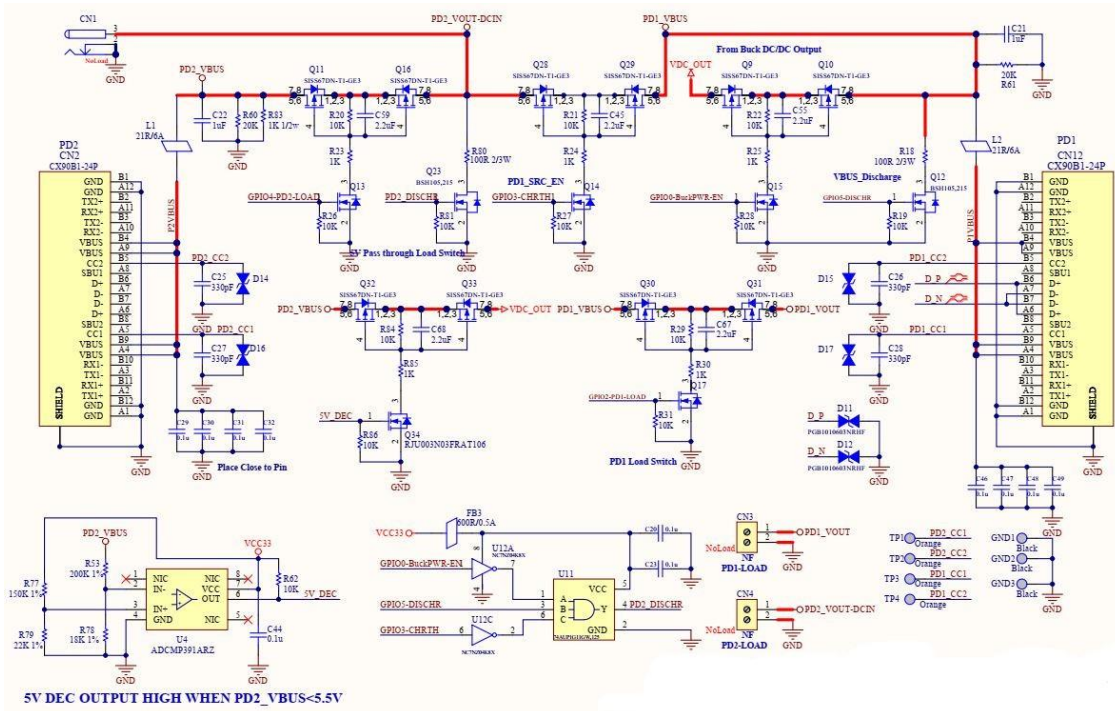

Figure 9 - PD1/PD2 Ports, Load Switches, 5V Detector and PD1/PD2 Discharging Circuit

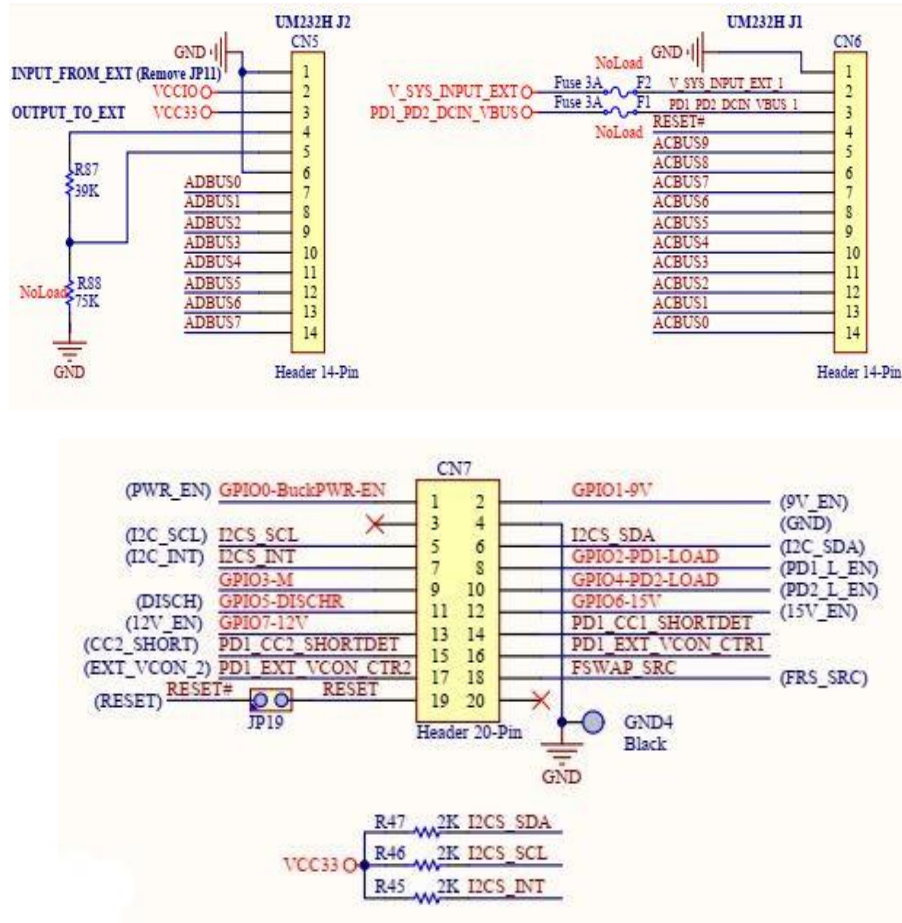

Figure 10 - Interfaces and Connectors

4 Power Delivery Functional Configuration

4.1 Pass-through

Pass-through is a feature where the input power on PD2 is passed through to PD1 to charge or power the device connected to PD1.

The block diagram in Figure 11 shows a use case in pass-through mode with charger plugged onto PD2 charges the PC that is plugged to PD1. (The EEPROM has been programmed to pass-through mode in the factory)

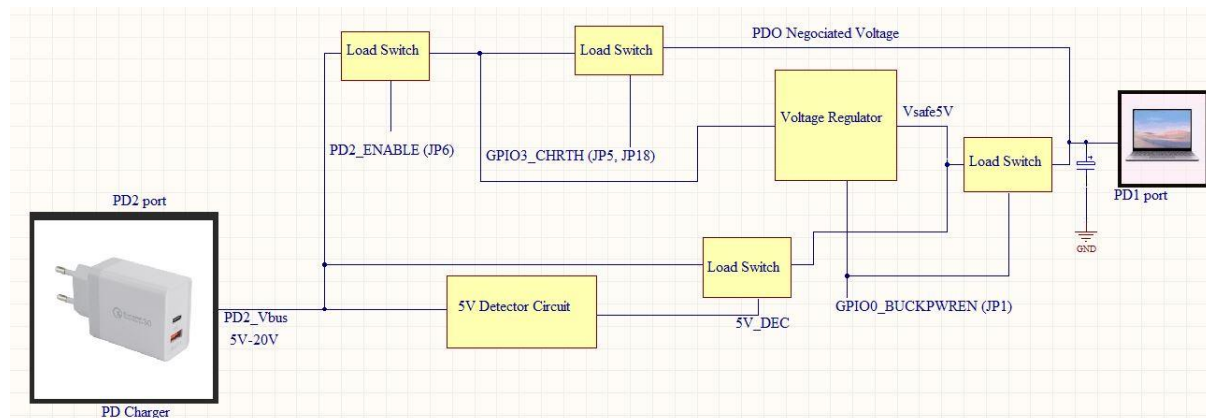

Figure 11 - Pass-through Block Diagram

Pass-through configuration:

Pin 1 of JP1 should be connected to Pin 2 of JP1: This is to enable the voltage regulator to provide the Vsafe5v. It is also enable the load switch (Q9, Q10 and Q15) to route the 5V from voltage regulator to the PD1 Vbus.

Pin 1 of JP6 should be connected to Pin 2 of JP6: This is to enable the PD2 load switch (Q11,Q16, Q13) to route the power from PD2 to the voltage regulator as well as to the input of the GPIO3-CHRTH load switch (Q28 Q29,Q14). Refer to Figure 11.

Pin 1 of JP5 should be connected to pin 2 of JP5. Pin 1 of JP18 should be connected to pin2 of JP18: This is to enable the GPIO3-CHRTH load switch (Q28, Q29 and Q14) to route the negotiated power from PD2 to PD1.

Pin 1 of JP7 should be connected to pin 2 of JP7: This is to control the discharge circuit on PD1 Vbus.

4.2 Dual Role

Dual Role is a feature where the input power from either PD2 or other external DC source is fed to the voltage regulator where different power supplies can be configured based on the power profile in the FT233HP external EEPROM to charge the device on PD1.

The block diagram in Figure 12 and Figure 13 shows two use cases in dual role mode where

- 1) Charger plugs onto PD2 is providing power to the voltage regulator that provide power to device plugged onto PD1 in accordance to the power profiles in the external EEPROM.
- 2) External DC source plugs onto CN1 providing power to the voltage regulator that provides power to device plugged onto PD1 in accordance to the power profiles in the external EEPROM.

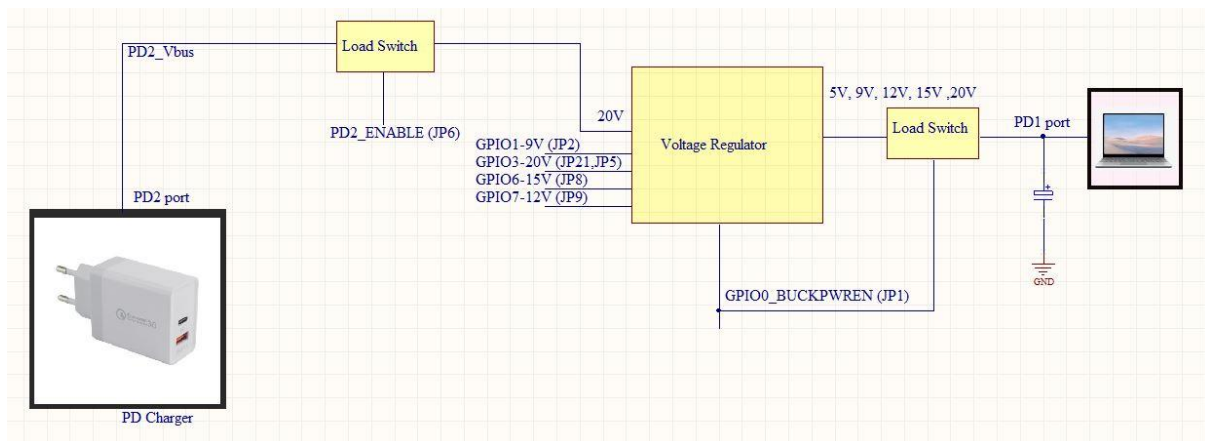
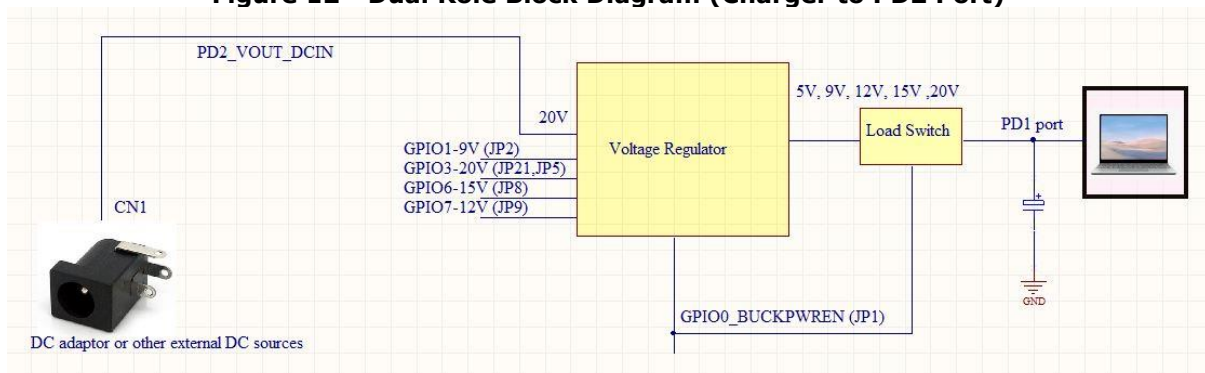
Figure 12 - Dual Role Block Diagram (Charger to PD2 Port)

Figure 13 - Dual Role Block Diagram (External DC to CN1)

Dual-role configuration

Pin 1 of JP1 should be connected to Pin 2 of JP1: This is to enable the voltage regulator to provide the power. It is also to enable the load switch (Q9, Q10 and Q15) to route the negotiated power from voltage regulator to the PD1 Vbus.

Pin 1 of JP2 should be connected to Pin 2 of JP2: This is to enable the resistor divider in the voltage regulator to provide 9V.

Pin 1 of JP5 should be connected to pin 2 of JP5. Pin 1 of JP21 should be connected to pin2 of JP21: This is to enable the resistor divider in the voltage regulator to provide 20V.

Pin 1 of JP8 should be connected to pin 2 of JP8: This is to control the resistor divider to provide 15V.

Pin 1 of JP9 should be connected to pin 2 of JP9: This is to control the resistor divider to provide 12V.

Pin 1 of JP7 should be connected to pin 2 of JP7: This is to control the discharge circuit on PD1 Vbus.

Precaution: Please do not feed power via PD charger and external DC source to the EVB at the same time.

4.3 Sink

Sink is feature where the PD2 or PD1 can be configured as sink mode when attached to a PD charger or other PD devices to provide power to the modules connected to the board. Figure 14 and Figure 15 shows two possible use case of sink configuration.

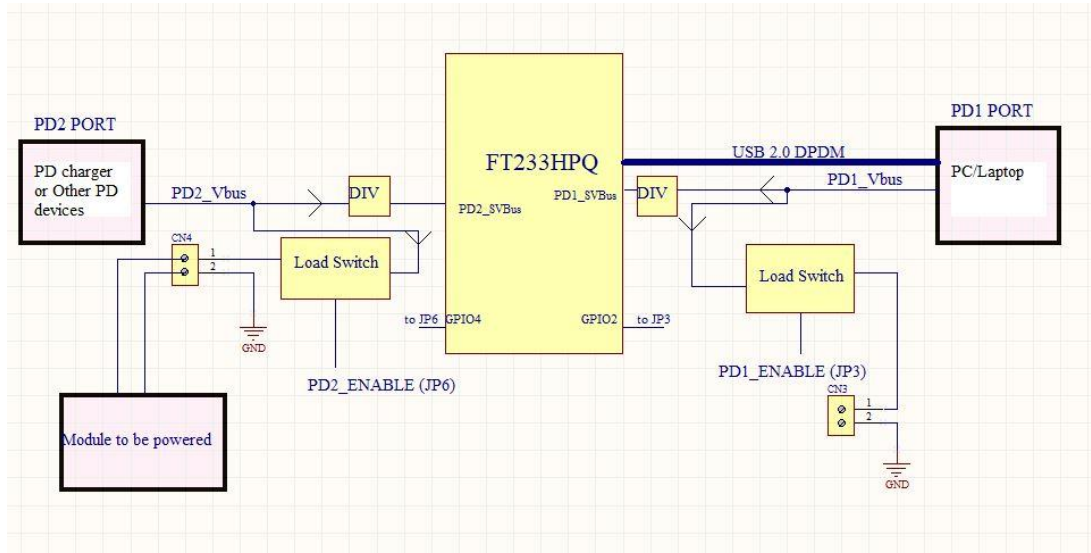

Figure 14 - Sink Block Diagram (PD1 Port as USB to Host PC, PD2 Port Sink Power into the Module from Charger)

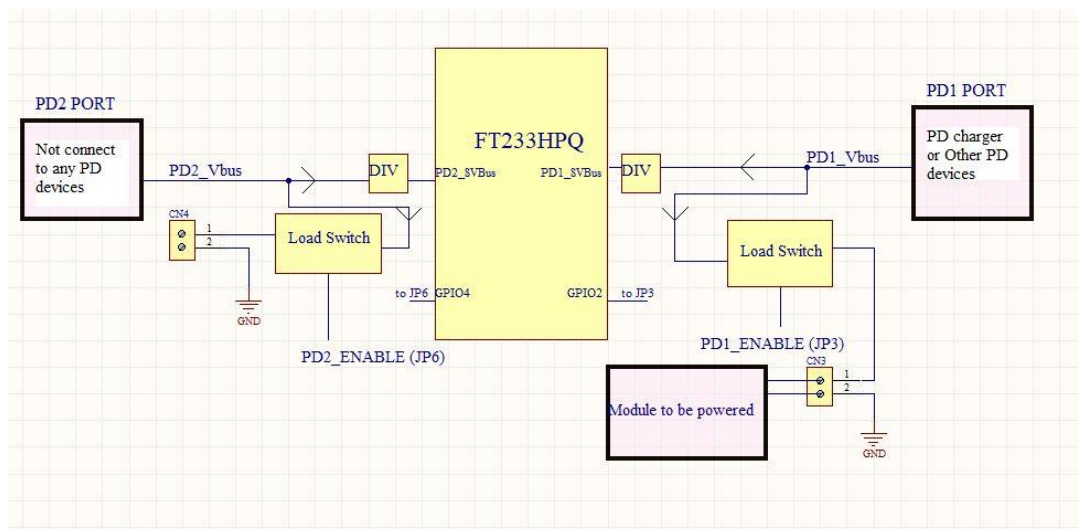

Figure 15 - Sink Block Diagram (PD1 Port Sink Power into the Module from Charger)

Sink Configurations

Pin 1 of JP3 should be connected to Pin 2 of JP3: This is to enable PD1 load switch to route the power from PD1 Vbus to PD1_Vout (CN3) to provide power to external modules or peripheral if required. The PD1 sink power profiles are configurable in EEPROM.

Pin 1 of JP6 should be connected to Pin 2 of JP6: This is to enable the PD2 load switch (Q11, Q16 and Q13) to route the power from PD2 to the PD2_Vbus_DCIN (CN4) to provide power to external modules or peripheral if required. The PD2 sink power profiles are configurable in EEPROM.

5 Mechanical Details

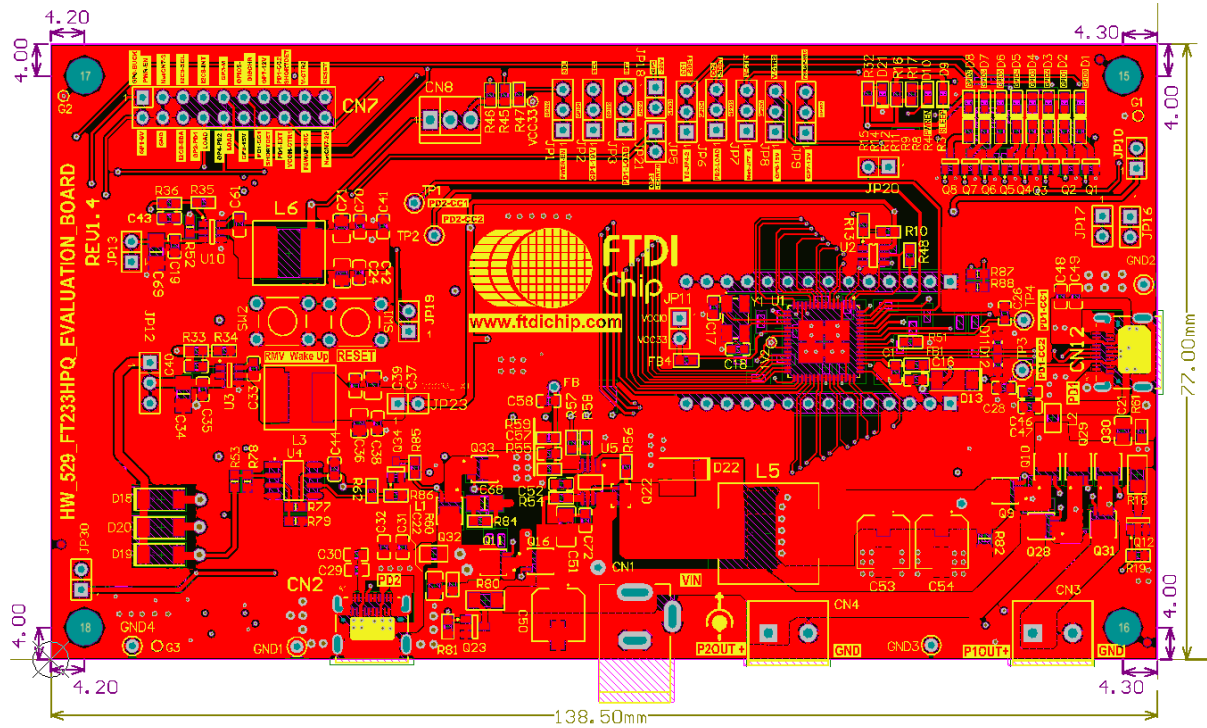

Figure 16 – UMFT233HPEV Evaluation Module Board - Mechanical Diagram - Top View

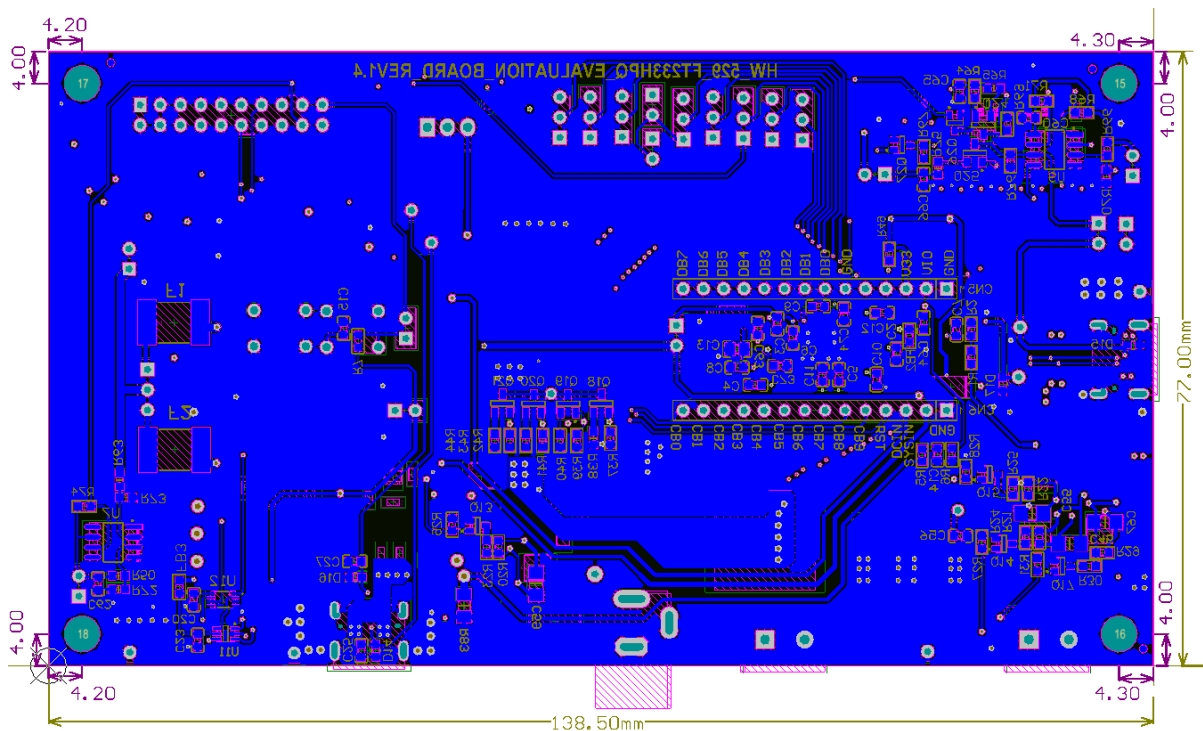

Figure 17 – UMFT233HPEV Evaluation Module Board - Mechanical Diagram - Bottom View

6 Contact Information

Head Office – Glasgow, UK

Future Technology Devices International Limited
Unit 1, 2 Seaward Place, Centurion Business Park
Glasgow G41 1HH
United Kingdom
Tel: +44 (0) 141 429 2777
Fax: +44 (0) 141 429 2758

E-mail (Sales) sales1@ftdichip.com
E-mail (Support) support1@ftdichip.com
E-mail (General Enquiries) admin1@ftdichip.com

Branch Office – Tigard, Oregon, USA

Future Technology Devices International Limited
(USA)
7130 SW Fir Loop
Tigard, OR 97223-8160
USA
Tel: +1 (503) 547 0988
Fax: +1 (503) 547 0987

E-mail (Sales) us.sales@ftdichip.com
E-mail (Support) us.support@ftdichip.com
E-mail (General Enquiries) us.admin@ftdichip.com

Branch Office – Taipei, Taiwan

Future Technology Devices International Limited
(Taiwan)
2F, No. 516, Sec. 1, NeiHu Road
Taipei 114
Taiwan, R.O.C.
Tel: +886 (0) 2 8797 1330
Fax: +886 (0) 2 8751 9737

E-mail (Sales) tw.sales1@ftdichip.com
E-mail (Support) tw.support1@ftdichip.com
E-mail (General Enquiries) tw.admin1@ftdichip.com

Branch Office – Shanghai, China

Future Technology Devices International Limited
(China)
Room 1103, No. 666 West Huaihai Road,
Shanghai, 200052
China
Tel: +86 21 62351596
Fax: +86 21 62351595

E-mail (Sales) cn.sales@ftdichip.com
E-mail (Support) cn.support@ftdichip.com
E-mail (General Enquiries) cn.admin@ftdichip.com

Web Site

<http://ftdichip.com>

Distributor and Sales Representatives

Please visit the Sales Network page of the [FTDI Web site](#) for the contact details of our distributor(s) and sales representative(s) in your country.

System and equipment manufacturers and designers are responsible to ensure that their systems, and any Future Technology Devices International Ltd (FTDI) devices incorporated in their systems, meet all applicable safety, regulatory and system-level performance requirements. All application-related information in this document (including application descriptions, suggested FTDI devices and other materials) is provided for reference only. While FTDI has taken care to assure it is accurate, this information is subject to customer confirmation, and FTDI disclaims all liability for system designs and for any applications assistance provided by FTDI. Use of FTDI devices in life support and/or safety applications is entirely at the user's risk, and the user agrees to defend, indemnify and hold harmless FTDI from any and all damages, claims, suits or expense resulting from such use. This document is subject to change without notice. No freedom to use patents or other intellectual property rights is implied by the publication of this document. Neither the whole nor any part of the information contained in, or the product described in this document, may be adapted or reproduced in any material or electronic form without the prior written consent of the copyright holder. Future Technology Devices International Ltd, Unit 1, 2 Seaward Place, Centurion Business Park, Glasgow G41 1HH, United Kingdom. Scotland Registered Company Number: SC136640

Appendix A – References

Document References

AN_448 [FT4233HP FT2233HP FT233HP Configuration Guide](#)

AN_449 [FT4233HP FT2233HP FT233HP FT4232HP FT2232HP FT232HP DCDC Power Delivery Application Note](#)

[FT233HP Datasheet](#)

Acronyms and Abbreviations

Terms	Description
EEPROM	Electrically Erasable Programmable Read-Only Memory
GPIO	General Purpose Input Output
PD	Power Delivery
USB	Universal Serial Bus
USB-IF	USB Implementer Forum

Appendix B – List of Tables and Figures

List of Tables

Table 1 - UMFT233HPEV Evaluation Board – Electrical Details – Label & Description	6
Table 2 - Jumper Pin Details for Power.....	6
Table 3 - Jumper Configuration Details for GPIO	8
Table 4 - Connector Pin Details of CN5.....	8
Table 5 - Connector Pin Details of CN6.....	9
Table 6 - Connector Pin Details of Ext MCU (CN7)	9

List of Figures

Figure 1 - UMFT233HPEV Evaluation Module Board.....	3
Figure 2 - UMFT233HPEV Evaluation Module Board – Top View	5
Figure 3 - UMFT233HPEV Evaluation Module Board – Bottom View	5
Figure 4 - Remote Wakeup Diagram	9
Figure 5 - DC to DC Converter for 3.46V and 3.3V from Vbus or External Power Supply	10
Figure 6 - FT233HPQ IC	11
Figure 7 - LED Driver Circuit for Power, GPIO and USB Activity	12
Figure 8 - Voltage Regulator for PD Profile Configurable with GPIOs	13
Figure 9 - PD1/PD2 Ports, Load Switches, 5V Detector and PD1/PD2 Discharging Circuit.....	14
Figure 10 - Interfaces and Connectors	14
Figure 11 - Pass-through Block Diagram	15
Figure 12 - Dual Role Block Diagram (Charger to PD2 Port).....	16
Figure 13 - Dual Role Block Diagram (External DC to CN1).....	16
Figure 14 - Sink Block Diagram (PD1 Port as USB to Host PC, PD2 Port Sink Power into the Module from Charger)	17
Figure 15 - Sink Block Diagram (PD1 Port Sink Power into the Module from Charger)	17
Figure 16 – UMFT233HPEV Evaluation Module Board - Mechanical Diagram - Top View	18
Figure 17 – UMFT233HPEV Evaluation Module Board - Mechanical Diagram - Bottom View	18

Appendix C – Revision History

Document Title: UMFT233HPEV Evaluation Module Datasheet
Document Reference No.: FT_001520
Clearance No.: FTDI#564
Product Page: <https://ftdichip.com/product-category/products/>
Document Feedback: [Send Feedback](#)

Revision	Changes	Date
1.0	Initial Release	24-11-2021