

REVISIONS				
SYM	ZONE	ECN, ERN NO.	DATE	APPRD.
A		PER ECN E07251	2007/07/26	L.CHAN

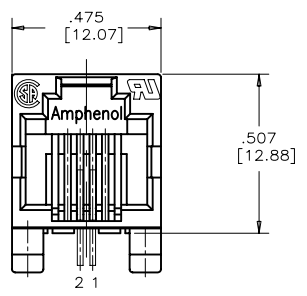

FRONT VIEW
RJE01-62001
RJE01-62001B

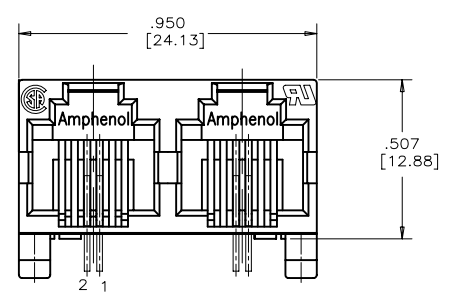

FRONT VIEW
RJE01-62002
RJE01-62002B

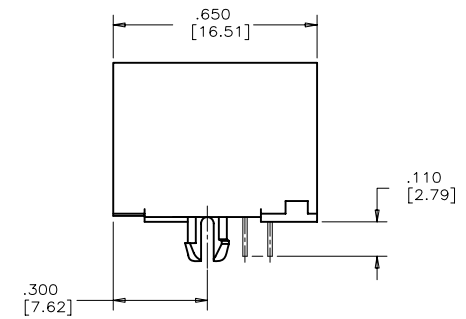

SIDE VIEW

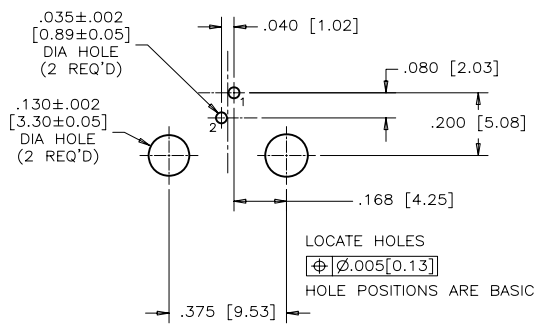

RECOMMENDED P.C.B. LAYOUT
(COMPONENT SIDE OF BOARD)
RJE01-62001
RJE01-62001B

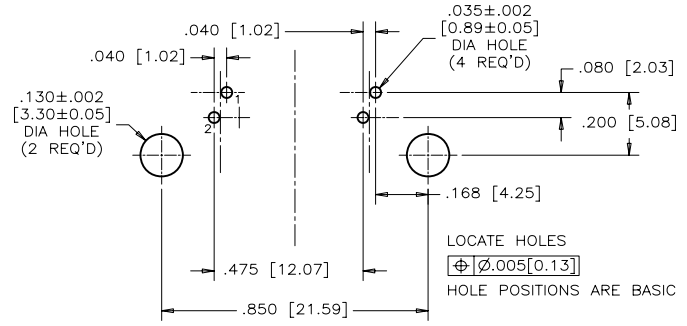

RECOMMENDED P.C.B. LAYOUT
(COMPONENT SIDE OF BOARD)
RJE01-62002
RJE01-62002B



AMPHENOL PART NUMBER: R J E 0 1 - 6 2 0 - 0 X X

1 = 1 PORTS
2 = 2 PORTS

BLANK = STANDARD PACKING (CURRENTLY TUBES)
B = TUBE PACKING REQUIRED

**DATA CONTROL
RELEASE**
DEPT. NO.--626--
DATE: DEC25,2007

MATERIALS:

- PLASTIC HOUSING: ENGINEERING THERMOPLASTIC
FLAMMABILITY RATING UL 94V-0.
COLOR: BLACK
- CONTACTS: PHOSPHOR BRONZE
- PLATING: 50 MICROINCHES [1.27 MICRONS] MINIMUM NICKEL.
50 MICROINCHES [1.27 MICRONS] MINIMUM GOLD
ON MATING SURFACES.
100 MICROINCHES [2.54 MICRONS] MATTE TIN ON CONTACT TAILS.

DRAWN	J.OUYANG	DATE	JUL26/07
DESIGNED			
CHECKED	MT.CHAN		JUL26/07
I. E. APPRD.	JEFF.S		JUL26/07
Q. A. APPRD.			
DWG. APPRD.			
ENG. REL. NO.	E07251	DWG	DRAWING NO.
REF.	EAR# A070710		
DIMENSIONS ARE IN	CODE ID. NO.		
INCHES [mm]	03554	SCALE	WT. ----- SURF. ----- SHEET 1 OF 1

Amphenol Canada Corp.

TITLE RJE01 SERIES HIGH SPEED MODULAR JACK,
1 & 2 PORT, 6 POSITIONS, 2 CONTACTS,
WITHOUT SHIELD - RoHS COMPLIANT

P-RJE01-620-0XX

REV. A

THIS DOCUMENT CONTAINS PROPRIETARY INFORMATION AND SUCH INFORMATION
MAY NOT BE DISCLOSED TO OTHERS FOR ANY PURPOSE OR USED FOR MANUFACTURING
PURPOSES WITHOUT WRITTEN PERMISSION FROM AMPHENOL CANADA CORP.