

HIGH ISOLATION VOLTAGE DARLINGTON TRANSISTOR TYPE SOP MULTI PHOTOCOUPLER

PS2702-1

FEATURES

- **HIGH ISOLATION VOLTAGE**
BV: 3.75 kV r.m.s. MIN
- **SOP (SMALL OUT-LINE PACKAGE)**
- **ISOLATED CHANNELS PER EACH PACKAGE**
- **HIGH CURRENT TRANSFER RATIO**
CTR: 200% MIN @ $I_F = 1 \text{ mA}$, $V_{CE} = 2 \text{ V}$
- **HIGH SPEED SWITCHING**
 $t_r, t_f = 200 \mu\text{s}$ TYP
- **TAPE AND REEL AVAILABLE**

DESCRIPTION

PS2702-1 is an optically coupled isolator containing a GaAs light emitting diode and an NPN silicon Darlington-connected phototransistor. This device is mounted in a plastic SOP (Small Outline Package) for high density applications and has a shield effect to cut off ambient light.

APPLICATIONS

Interface circuit for various instrumentations and control equipment.

- **AC LINE/DIGITAL LOGIC**
- **DIGITAL LOGIC INTERFACE**
- **TWISTED PAIR LINE RECEIVER**
- **TELEPHONE/TELEGRAPH LINE RECEIVER**
- **HIGH FREQUENCY POWER SUPPLY FEEDBACK CONTROL**
- **RELAY CONTACT MONITOR**
- **POWER SUPPLY MONITOR**

ELECTRICAL CHARACTERISTICS ($T_A = 25^\circ\text{C}$)

PART NUMBER			PS2702-1		
SYMBOLS	PARAMETERS	UNITS	MIN	TYP	MAX
Diode	V_F	Forward Voltage, $I_F = 5 \text{ mA}$	V	1.1	1.4
	I_R	Reverse Current, $V_R = 5 \text{ V}$	μA		5
	C_t	Terminal Capacitance, $V = 0$, $f = 1.0 \text{ MHz}$	pF	30	
Transistor	I_{CEO}	Collector to Emitter Dark Current, $V_{CE} = 40 \text{ V}$, $I_F = 0$	nA		400
Coupled	CTR	Current Transfer Ratio ¹ , $I_F = 1 \text{ mA}$, $V_{CE} = 2 \text{ V}$	%	200	2000
	$V_{CE}(\text{sat})$	Collector Saturation Voltage, $I_F = 1 \text{ mA}$, $I_C = 2 \text{ mA}$	V		1.0
	RI-O	Isolation Resistance, $V_{in-out} = 1.0 \text{ kV DC}$	Ω	10^{11}	
	CI-O	Isolation Capacitance, $V = 0$, $f = 1.0 \text{ MHz}$	pF	0.4	
	t_r	Rise Time ² , $V_{CC} = 5 \text{ V}$, $I_C = 2 \text{ mA}$, $R_L = 100 \Omega$	μs	200	
t_f	Fall Time ² , $V_{CC} = 5 \text{ V}$, $I_C = 2 \text{ mA}$, $R_L = 100 \Omega$	μs	200		

Notes:

- CTR rank
K: 2000 to (%)
L: 700 to 3400 (%)
M: 200 to 1000 (%)

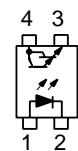

PS2702-1

2. Test Circuit for Switching Time

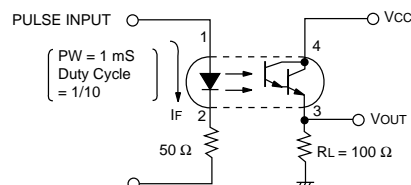

ABSOLUTE MAXIMUM RATINGS¹ (T_A = 25°C)

SYMBOLS	PARAMETERS	UNITS	RATINGS
			PS2702 -1
Diode			
I _F	Forward Current (DC)	mA	50
V _R	Reverse Voltage	V	6
P _D	Power Dissipation	mW/Ch	80
ΔP _D /°C	Power Dissipation Derating	mW/°C	0.8
I _F (PEAK)	Peak Forward Current (PW = 100 μs, Duty Cycle 1%)	A	1
Transistor			
V _{CEO}	Collector to Emitter Voltage	V	40
V _{ECO}	Emitter to Collector Voltage	V	6
I _C	Collector Current	mA/Ch	200
P _C	Power Dissipation	mW/Ch	150
ΔP _C /°C	Power Dissipation Derating	mW/°C	1.5
Coupled			
BV	Isolation Voltage ²	V _{r.m.s.}	3750
T _{STG}	Storage Temperature	°C	-55 to +150
T _A	Ambient Temperature	°C	-55 to +100

Notes:

1. Operation in excess of any one of these parameters may result in permanent damage.
2. AC voltage for 1 minute at T_A = 25 °C, RH = 60 % between input and output.

TYPICAL PERFORMANCE CURVES (T_A = 25°C)

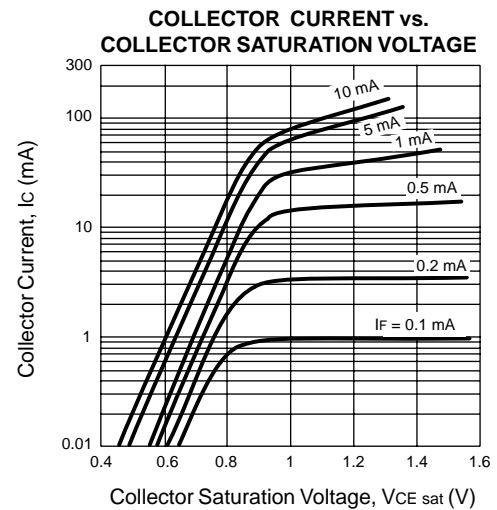
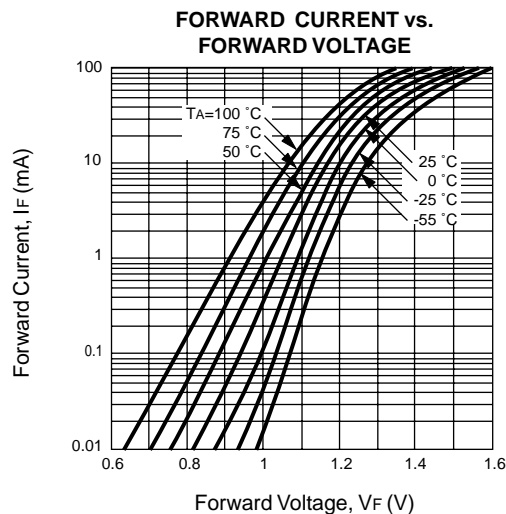
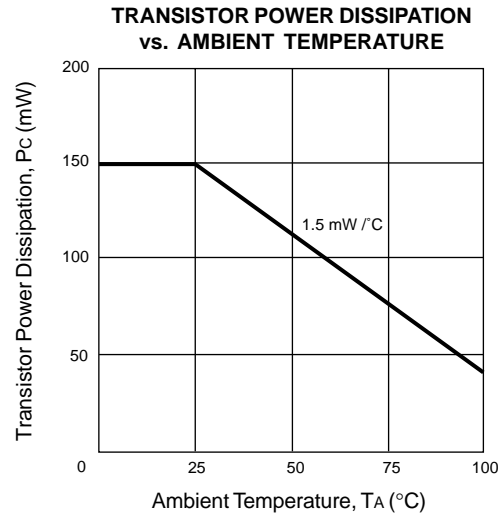
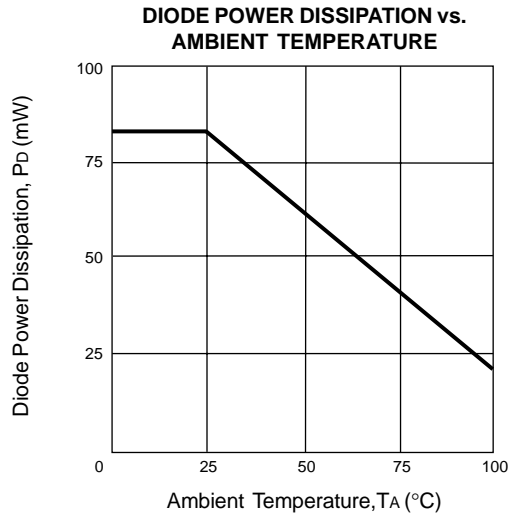

TYPICAL PERFORMANCE CURVES ($T_A = 25^\circ\text{C}$)

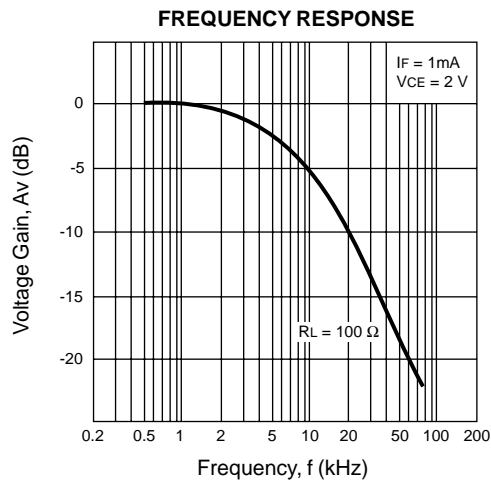
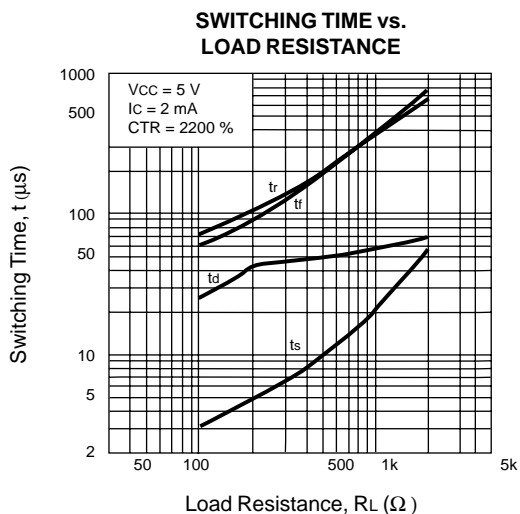
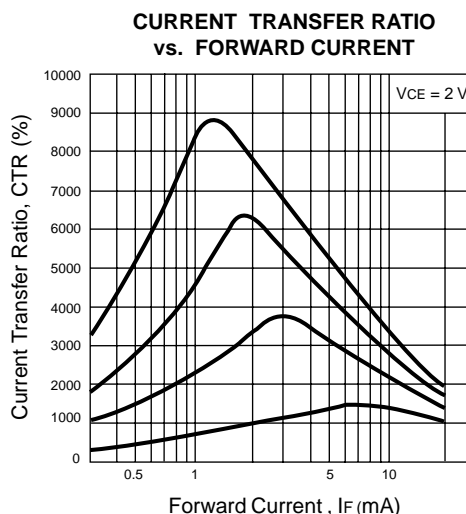
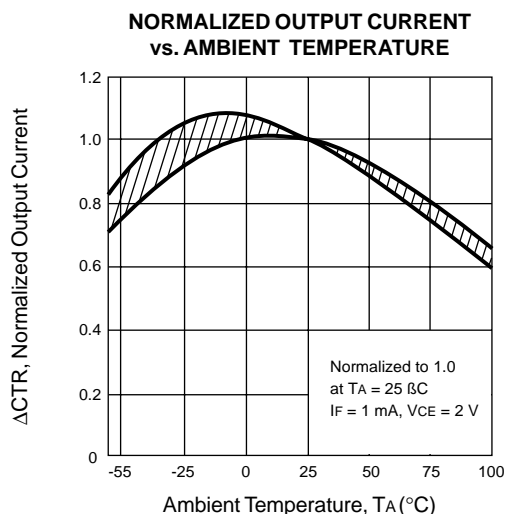
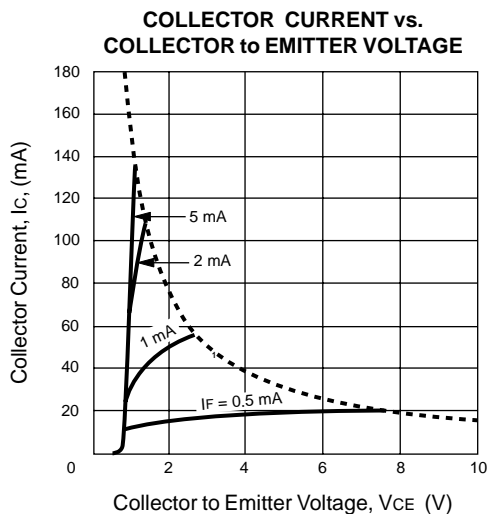
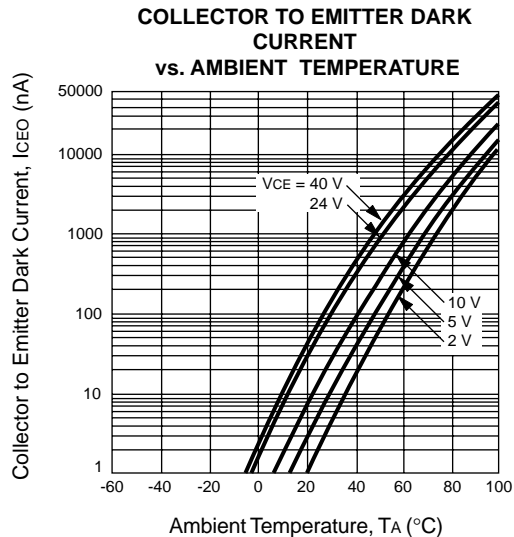

TYPICAL PERFORMANCE CURVES (TA = 25 °C)

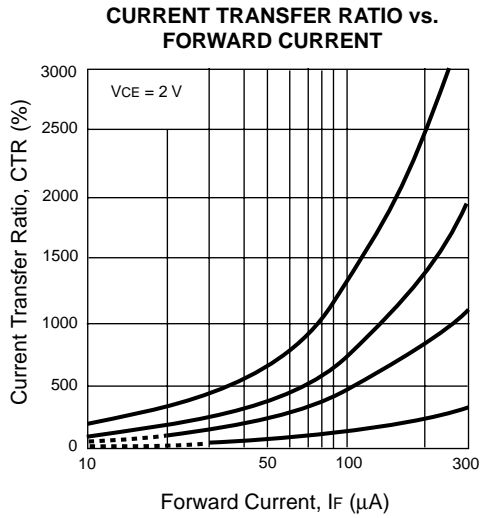
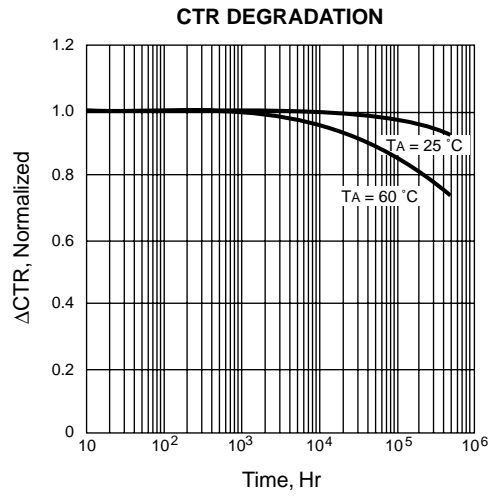
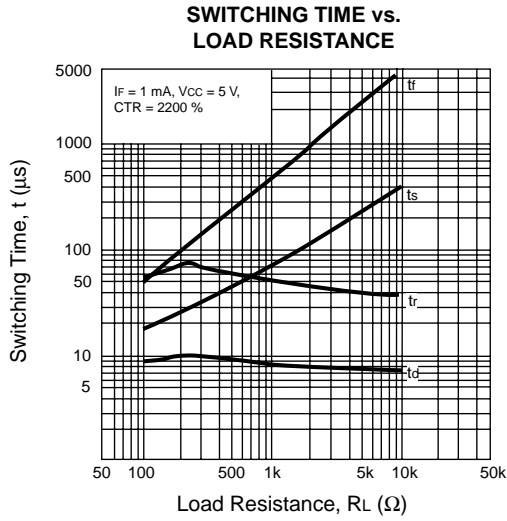

OUTLINE DIMENSIONS (Units in mm)

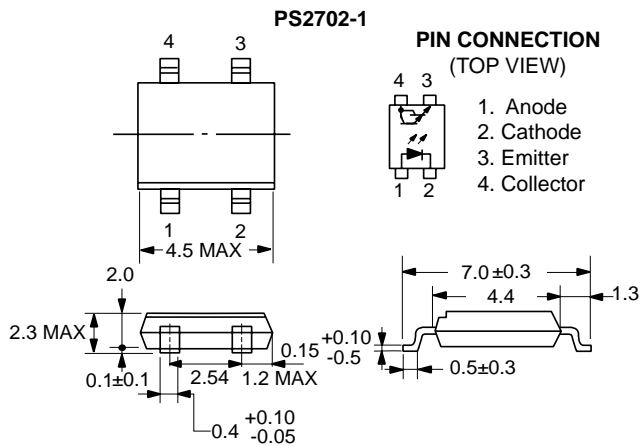

TAPING SPECIFICATIONS (Units in mm)

OUTLINE AND DIMENSIONS (TAPE)

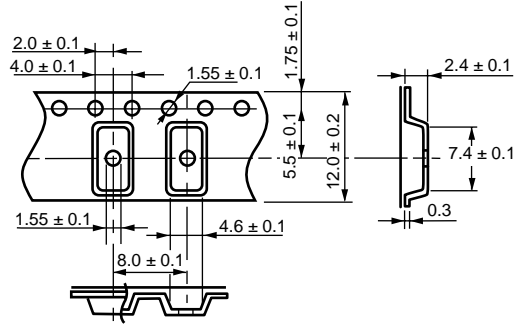

TAPING DIRECTION

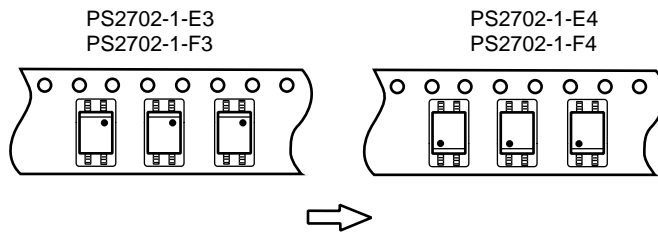

OUTLINE AND DIMENSIONS (REEL)

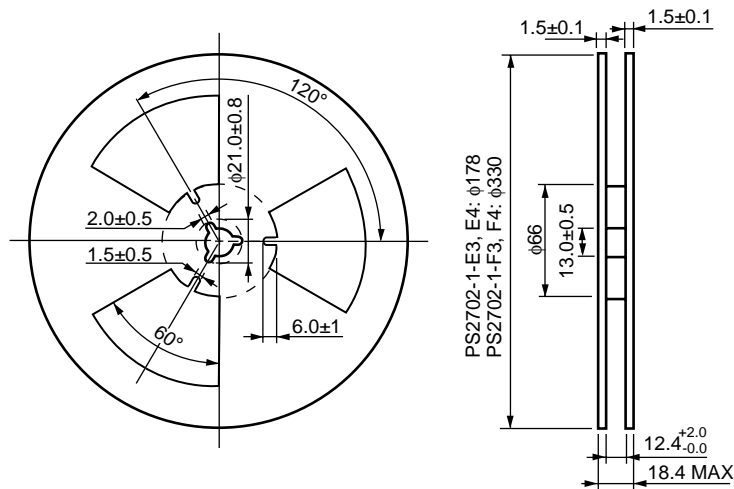

Packing: PS2702-1-E3, E4 900 pcs/reel
 PS2702-1-F3, F4 3500 pcs/reel

RECOMMENDED SOLDERING CONDITIONS

(1) Infrared reflow soldering

- **Peak reflow temperature** 235 °C (package surface temperature)
- **Time of temperature higher than 210 °C** 30 seconds or less
- **Number of reflows** Three
- **Flux** Rosin flux containing small amount of chlorine (The flux with a maximum chlorine content of 0.2 Wt % is recommended).

Recommended Temperature Profile of Infrared Reflow

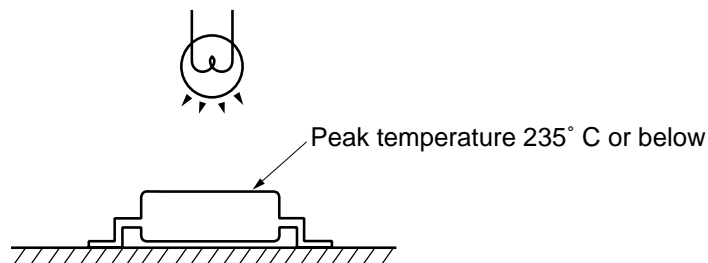
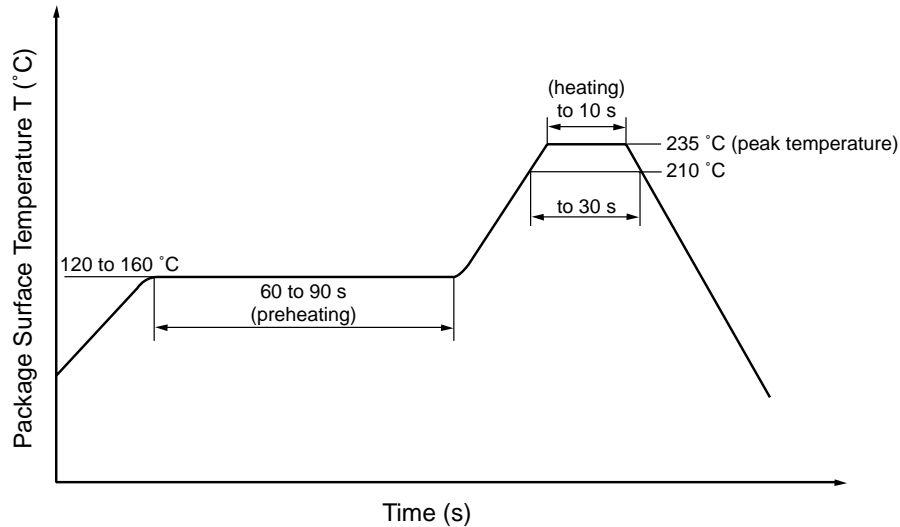

(2) Dip soldering

- **Temperature** 260 °C or below (molten solder temperature)
- **Time** 10 seconds or less
- **Number of times** One
- **Flux** Rosin flux containing small amount of chlorine (The flux with a maximum chlorine content of 0.2 Wt % is recommended).

(3) Cautions

- **Fluxes**

Avoid removing the residual flux with freon-based and chlorine-based cleaning solvent.