

30W

AC-DC POWER SUPPLIES

The EML30 is a series of open frame and encapsulated AC-DC single output power supplies designed for medical applications. The series provides a number of flexible mechanical options including PCB mount, open frame, chassis mount with screw terminals and a DIN Rail option. With approvals to world-wide medical safety standards, compliance with class B for both conducted and radiated emissions and a 130%, 30s peak load capability, these class II isolation parts benefit system designers with easy integration into the latest healthcare products and applications.



Features

- Compact size
- Medical approvals
- Single outputs from 3.3 to 48V
- PCB mount, open frame and chassis mount
- Encapsulated PCB and chassis mount
- Class II
- Peak load capability
- 3 year warranty

Applications



Healthcare



Home
Healthcare



Medical
Diagnostic

Dimensions

EML30:

(-P): 2.96 x 1.36 x 1.05" (75.2 x 34.6 x 26.7 mm)

(-T): 3.46 x 1.36 x 1.00" (87.9 x 34.6 x 25.4 mm)

(-E): 3.10 x 1.50 x 1.10" (78.7 x 38.1 x 27.9 mm)

(-S): 3.78 x 1.57 x 1.12" (96.0 x 40.0 x 28.5 mm)

Models & Ratings

Model Number ^(2,3)	Output Voltage	Output Current		Output Power
		Nominal	Peak ⁽¹⁾	
EML30US03	3.3VDC	6.00A	7.80A	20W
EML30US05	5.0VDC	6.00A	7.80A	30W
EML30US09	9.0VDC	3.33A	4.33A	30W
EML30US12	12.0VDC	2.50A	3.25A	30W
EML30US15	15.0VDC	2.00A	2.60A	30W
EML30US24	24.0VDC	1.25A	1.63A	30W
EML30US36	36.0VDC	0.83A	1.08A	30W
EML30US48	48.0VDC	0.62A	0.81A	30W

Notes:

1. Peak load lasting <30 s with a maximum duty cycle of 10%, average output power not to exceed nominal.
2. Add suffix to model number to define type: add '-P' for PCB mount, add '-T' for chassis mount, add '-E' for encapsulated, add '-S' for screw terminals.
3. A Screw terminal version (-S) is available with DIN clip attached, add suffix 'D', e.g. EML30US24-SD, DIN rail mounting kit is available as a separate item, order code ECL25/30 DIN CLIP.

Summary

Characteristic	Minimum	Typical	Maximum	Units	Notes & Conditions
Input Voltage Range	85		264	VAC	Derate from 100% at 90VAC to 90% at 85VAC
	120		370	VDC	
No Load Input Power			0.3	W	
Efficiency	79		88	%	
Operating Temperature	-20		+70	°C	Derate linearly from 100% at +50°C to 50% at +70°C
EMC	EN55032/11 Level B Conducted & Radiated, EN61000-3, EN61000-4, EN60601-1-2				
Safety Approvals	EN60601-1, ANSI/AAMI ES60601-1, IEC60601-1				

Input

Characteristic	Minimum	Typical	Maximum	Units	Notes & Conditions
Input Voltage Range	85		264	VAC	
	120		370	VDC	
Input Frequency	47		63	Hz	
Input Current - Full Load		0.55/0.32		A rms	At 115/230VAC
No Load Input Power			0.3	W	
Inrush Current		20/40		A	At 115/230VAC
Earth Leakage Current					Class II construction no earth
Input Protection	T2AL/250VAC internal fuse fitted in line and neutral				

Output

Characteristic	Minimum	Typical	Maximum	Units	Notes & Conditions
Output Voltage	3.3		48	VDC	See Models & Ratings
Initial Set Accuracy			±1	%	
Output Voltage Adjustment			±5	%	Not encapsulated units
Minimum Load	0			A	No minimum load required
Line Regulation			±0.5	%	
Load Regulation			±1	%	
Start Up Delay			2	s	
Start Up Rise Time			14	ms	
Hold Up Time	12			ms	At full load and 115VAC
Transient Response			4	%	Deviation, recovery within 1% in less than 500µs for a 25% load change
Ripple & Noise			50	mV pk-pk	3.3-5V, 20MHz bandwidth
			120	mV pk-pk	12-15V, 20MHz bandwidth
			200	mV pk-pk	24-48V, 20MHz bandwidth
Overvoltage Protection	195		216	% Vnom	3.3V versions, recycle input to reset
	115		140	% Vnom	All other versions, recycle input to reset
Overload Protection	120		185	%	
Short Circuit Protection					Trip & Restart (hiccup mode)
Temperature Coefficient			0.05	%/°C	

General

Characteristic	Minimum	Typical	Maximum	Units	Notes & Conditions
Efficiency	79		88	%	
Isolation: Input to Output	4000			VAC	
Switching Frequency		70		kHz	
Power Density			7	W/in ³	PCB Mount version
Mean Time Between Failure		>400		khrs	MIL-HDBK-217F, +25°C GB
Weight		0.13 (60)		lb (g)	Open frame versions
		0.35 (160)			Encapsulated version
		0.37 (170)			Screw terminal version

Environmental

Characteristic	Minimum	Typical	Maximum	Units	Notes & Conditions
Operating Temperature	-20		+70	°C	Derate linearly from 100% at +50°C to 50% at +70°C
Storage Temperature	-40		+85	°C	
Cooling	Convection-cooled				
Humidity			95	%RH	Non-condensing
Operating Altitude			3048	m	
Shock	IEC68-2-27, 30g, 11ms half sine, 3 times in each of 6 axes				
Vibration	IEC68-2-6, 2g, 10Hz to 500kHz, 10 mins/cycle, 60 mins each cycle				

EMC: Emissions

Phenomenon	Standard	Test Level	Notes & Conditions
Conducted	EN55032/11	Class B	
Radiated	EN55032/11	Class B	
Harmonic Current	EN61000-3-2	Class A	
Voltage Flicker	EN61000-3-3		

EMC: Immunity

Phenomenon	Standard	Test Level	Criteria	Notes & Conditions
ESD Immunity	EN61000-4-2	4	A	
Radiated Immunity	EN61000-4-3	10 V/m	A	Acc. IEC60601-1-2 4th Ed
EFT/Burst	EN61000-4-4	3	A	
Surge	EN61000-4-5	3	A	
Conducted	EN61000-4-6	10Vrms	A	
Magnetic Fields	EN61000-4-8	30A/m	A	
Dips and Interruptions	EN60601-1-2	70% U_T for 500ms	A	
		0% U_T for 20ms	A	
		0% U_T for 5000ms	B	

Safety Approvals

Certification	Standard	Notes & Conditions
CB Report	IEC60601-1 Ed 3 Including Risk Management	Medical
UL	ANSI/AAMI ES60601-1:2005 & CSA C22.2, No.60601-1:08	
TUV	EN60601-1/A11:2011	
CE	Meets all applicable directives	
UKCA	Meets all applicable legislation	
Means of Protection		Category
Primary to Secondary	2 x MOPP (Means of Patient Protection)	IEC60601-1 Ed 3

Mechanical Details

Open Frame - PCB Mount (-P)

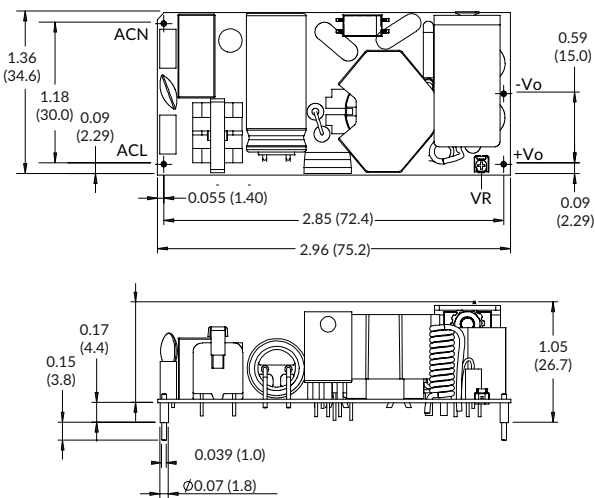

Encapsulated (-E)

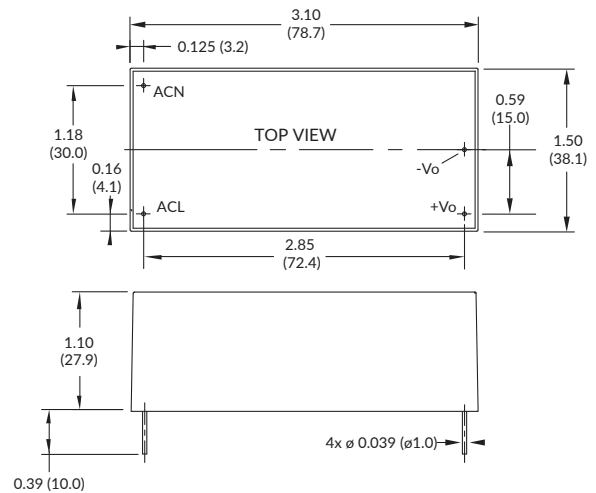

Notes:

- Dimensions in inches (mm).
- Weight: P Version: 0.13 lbs (60 g)
T Version: 0.13 lbs (60 g)
E Version: 0.35 lbs (160 g)
S Version: 0.37 lbs (170 g)
- Tolerances: x.xx = ± 0.02 (x.x = ± 0.5)
x.xxx = ± 0.01 (x.xx = ± 0.25)
- Heatsink is only fitted to 3V3, 5V and 9V models

Mating Connectors (-T version only)

Input Connector: JST XHP-3

Output Connector: JST XHP-6

Crimps: SPH-002T-P0.5S

Cable harness with 300mm wire available, order part no. ECL25 LOOM KIT

Mechanical Details

Open Frame - Chassis Mount (-T)

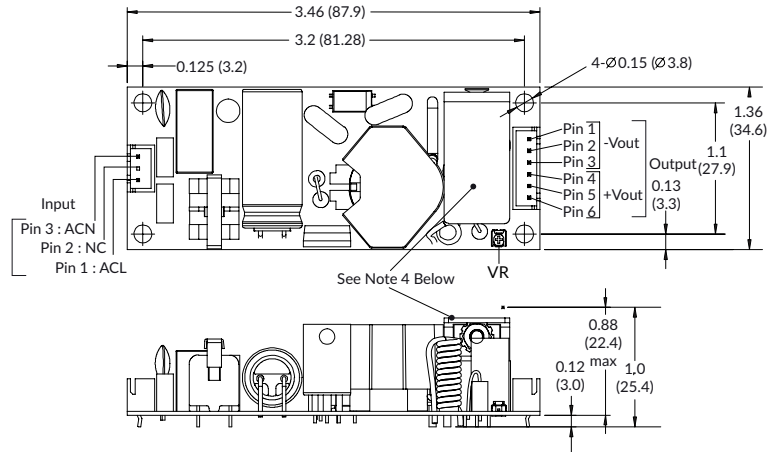

Screw Terminal (-S)

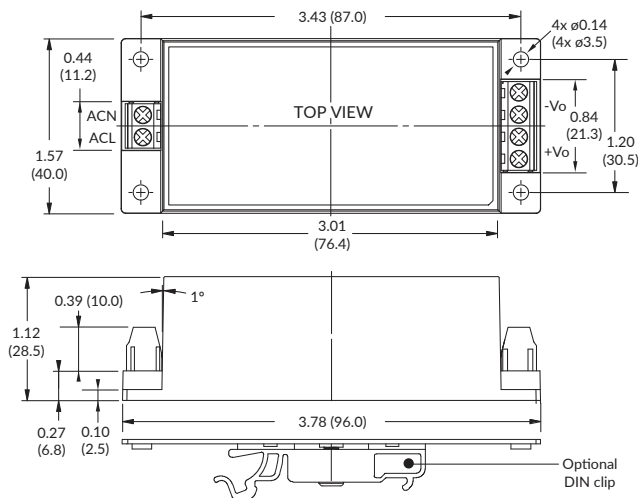

Notes:

1. Dimensions in inches (mm).
2. Weight: P Version: 0.13 lbs (60 g)
T Version: 0.13 lbs (60 g)
E Version: 0.35 lbs (160 g)
S Version: 0.37 lbs (170 g)
3. Tolerances: x.xx = ± 0.02 (x.x = ± 0.5)
x.xxx = ± 0.01 (x.xx = ± 0.25)
4. Heatsink is only fitted to 3V3, 5V and 9V models

Mating Connectors (-T version only)

Input Connector: JST XHP-3
Output Connector: JST XHP-6
Crimps: SPH-002T-P0.5S
Cable harness with 300mm wire available, order part no. ECL25 LOOM KIT