

## Using the ADAU1381 Sound Engine

### INTRODUCTION

This user guide explains the signal flow and parameter settings for the ADAU1381 sound engine. The ADAU1381 is ideal for low power portable applications, such as digital camera audio. During the recording or playing back of audio, the sound engine provides many signal processing features to improve audio quality.

### DIGITAL CAMERA SYSTEM OVERVIEW

Although the ADAU1381 is flexible enough to be used in several types of portable audio applications, its design specifically targets digital camera systems. The sound processing engine was, therefore, designed especially with such a system in mind. In general, digital cameras use audio processing when recording or playing back video. When recording, one or more microphones mounted in the camera or connected externally capture the audio data, which is then stored in the memory along with the video data. During playback or review mode, the audio data is retrieved from memory and played back through a speaker mounted in the camera or through a jack for headphones or other external connections.

In record mode, the source is an audio transducer (microphone) and the target is memory. In playback mode, the source is memory and the target is an audio transducer (speaker). In both modes, the sound engine is positioned between the source and target, processing the signal to improve audio quality.

Because the required audio processing differs depending on the operating mode of the camera, several audio processing modes have been implemented in the sound engine of the ADAU1381.

### AUDIO PROCESSING MODES

#### Record Mode

Record mode takes audio input from a microphone. Wind noise reduction is applied to remove unwanted noise from the signal and improve audio clarity. The enhanced stereo capture algorithm provides improved stereo separation when microphones are spaced close together. The six-band equalizer can be programmed to augment bands of interest and filter out unwanted frequencies. The dual-band dynamics processor acts as an automatic level control, compensating for fluctuating input signal levels. The processed signal is output to a digital storage medium.

Two record modes exist: Record A (**REC A**) and Record B (**REC B**). The only differences between the two modes are the six-band equalizer and the dual-band dynamics processor settings. The two record modes allow for different audio recording profiles, such as voice or music. The recording profile can be changed by a single write to the RAM parameter.

#### Playback Mode

Playback mode takes audio input from the digital storage. The six-band equalizer is used for frequency compensation with the output speaker or headphones. The dual-band dynamics processor acts as a compressor, allowing for suitable playback levels even in noisy environments. The playback output includes a digital volume control for output level adjustment.

### SOUND ENGINE SIGNAL FLOW BLOCK DIAGRAM

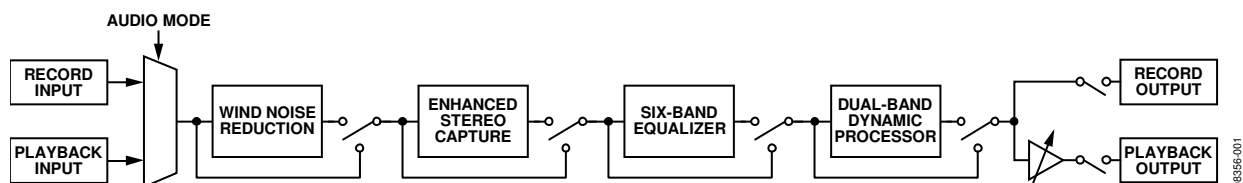

Figure 1.

**TABLE OF CONTENTS**

Introduction .....	1	Outputs and Mute .....	4
Digital Camera System Overview .....	1	Mode Selection .....	4
Audio Processing Modes .....	1	Main Page .....	4
Sound Engine Signal Flow Block Diagram .....	1	Wind Noise Reduction Page .....	6
Revision History .....	2	Enhanced Stereo Capture Page.....	8
SigmaStudio Interface to the Sound Engine .....	3	Equalization Filters Page .....	9
SigmaStudio Interface .....	3	Dual-Band Compression Page.....	14
ADAU1381 Power-Up Sequence.....	3	SigmaStudio Tools .....	27
Connecting the ADAU1381 Evaluation Board to the Computer.....	3	Changing Sample Rate.....	27
Editing the Signal Flow.....	3	Capture Window .....	27
Controlling Parameters in Real Time.....	3	Parameter Visualization Window .....	27
Output File Generation.....	3	Sequence Window.....	27
Sound Engine Signal Processing Flow.....	4	Export Parameter and Register Settings.....	28
Description.....	4	SigmaStudio Help File .....	28
Inputs .....	4	Full Parameter Map.....	29

**REVISION HISTORY**

11/09—Revision 0: Initial Version

## SIGMASTUDIO INTERFACE TO THE SOUND ENGINE

### SIGMASTUDIO INTERFACE

SigmaStudio™ is a software tool that allows the user to configure the registers and parameters of the ADAU1381 via a graphical user interface. SigmaStudio can communicate directly with target hardware via the EVAL-ADUSB2EBZ board, also known as the USBi, which uses the I<sup>2</sup>C<sup>®</sup> and SPI communications protocols. The ADAU1381 evaluation board is configured for use with the USBi. Prototype hardware can also be configured for a USBi connection using a 10-pin communications header.

More information on the USBi can be found in the AN-1006 application note at [www.analog.com](http://www.analog.com).

### ADAU1381 POWER-UP SEQUENCE

When power is supplied to the ADAU1381, a boot sequence is initiated to clear the memory to a default state. When the boot sequence is complete, all of the sound engine parameters are set to 0. The parameters in the ADAU1381 memory do not match the values shown in SigmaStudio until they are overwritten.

### CONNECTING THE ADAU1381 EVALUATION BOARD TO THE COMPUTER

To connect the ADAU1381 to the computer, complete the following steps:

1. Install SigmaStudio; refer to the evaluation board documentation for step-by-step instructions.
2. Set up the USBi and ADAU1381 evaluation board as described in the evaluation board documentation.
3. Connect the USBi to the PC with a USB cable and install the drivers as described in the AN-1006 application note.
4. Connect the communications ribbon cable to the target ADAU1381 board to initiate the built-in hardware self-boot function of the ADAU1381.
5. Run SigmaStudio.
6. Open the ADAU1381.dspproj file, which is located in the SigmaStudio program directory.
7. Write registers and parameters from SigmaStudio to the hardware to enable the audio signal paths. To download all parameters for the ADAU1381.dspproj file at once, click **Link-Compile-Download** in the main toolbar.

### EDITING THE SIGNAL FLOW

The signal flow of the ADAU1381 is fixed function. The corresponding SigmaStudio project file is locked. Therefore, no cells can be added to or deleted from the project. Only the parameters and register settings can be modified.

### CONTROLLING PARAMETERS IN REAL TIME

SigmaStudio can be used for real-time tuning of the evaluation board or a production system via the USBi control interface. The method for changing the parameters of each cell is described in the help documentation for that cell.

New parameter values should always be generated within the SigmaStudio tool. The default minimum and maximum limits for each control should be obeyed.

### OUTPUT FILE GENERATION

SigmaStudio includes built-in code and header file generation tools that can greatly simplify integration in the host controller of a target system. Parameter values and register settings can easily be exported via the **Export System Files** command in SigmaStudio to C-compatible output files.

## SOUND ENGINE SIGNAL PROCESSING FLOW

The sound engine processing flow of the ADAU1381 is partitioned into multiple hierarchy pages in the SigmaStudio tool. In this section, each page and its corresponding controls and parameters are described in detail.

### DESCRIPTION

The main page presents an overview of the signal flow, with the processing blocks of the sound engine presented as hierarchy boards. Using the main page controls, the audio modes and output volumes can be modified.

### INPUTS

There are four audio inputs to the sound engine: **Record Input 0**, **Record Input 1**, **Playback Input 0**, and **Playback Input 1**. The source of the signals on the record inputs is the ADCs or digital microphones. **Record Input 0** comes from the left ADC or **Digital Microphone Input 1** (the LMIC/LMICN/MICD1 pin), and **Record Input 1** comes from the right ADC or **Digital Microphone Input 2** (the RMIC/RMICN/MICD2 pin). The inputs to the playback path are from the digital serial data interface. **Digital Serial Input 0** (the left channel of the DAC\_SDATA/GPIO0 pin) is connected to **Playback Input 0**, and **Digital Serial Input 1** (the right channel of the DAC\_SDATA/GPIO0 pin) is connected to **Playback Input 1**.

These two input pairs are routed to the subsequent processing blocks based on the mode selections. In **REC A** and **REC B** modes, the record input pair is routed through the processing algorithms; in playback mode, the playback input pair is routed through the processing algorithms.

### MAIN PAGE

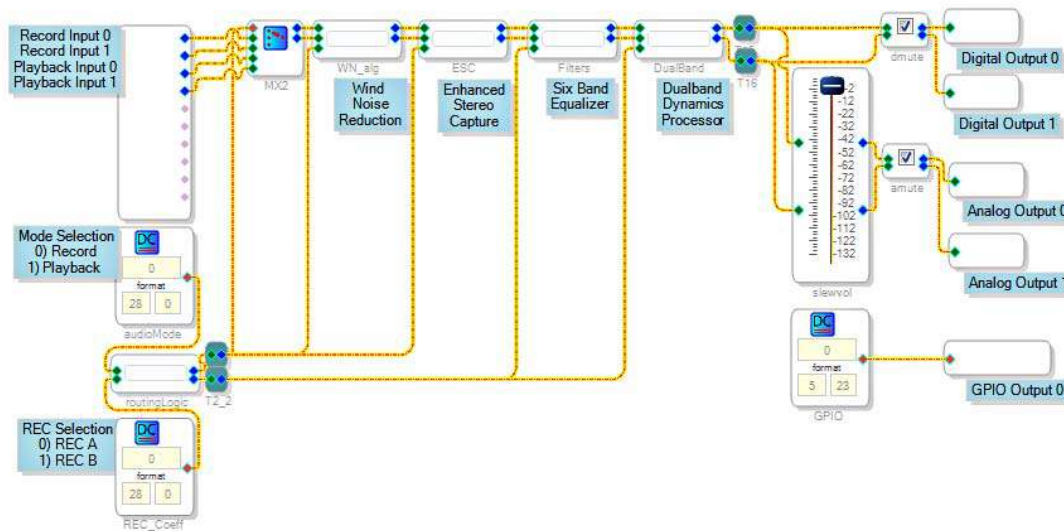

Figure 2. Main Page

08356-002

### OUTPUTS AND MUTE

There are four audio outputs from the sound engine: **Record Output 0**, **Record Output 1**, **Playback Output 0**, and **Playback Output 1**. The record output signals (also labeled as **Digital Output 0** and **Digital Output 1**) are sent to the digital serial data interface, and the playback output signals (also labeled as **Analog Output 0** and **Analog Output 1**) go to the DACs of the ADAU1381. **Playback Output 0** is sent to the left DAC, and **Playback Output 1** is sent to the right DAC.

The digital and analog outputs have separate mute settings. In SigmaStudio, each of these is enabled by checking the appropriate box for the mute control.

There is a single flag in the sound engine that outputs a high or a low logic signal on the GPIO pin of the ADAU1381. This output is set by writing either a 0 or a 1 to the **GPIO** parameter.

### MODE SELECTION

The sound engine can be put into three modes: **REC A** (Record A), **REC B** (Record B), or **Playback**. Using the settings on the two mode selection blocks, the routing logic properly configures the signal flow for the selected mode. The parameter settings for each mode are shown in Table 1.

Table 1. Record/Playback Modes

Mode	Mode Selection	REC Selection
REC A (Record A)	0	0
REC B (Record B)	0	1
Playback	1	Don't care

**Controls**

Set the audio mode by typing 0 or 1 into the **audioMode** cell in the default 28.0 format (see Figure 3). More information on 28.0 and other numeric formats can be found in the Numeric Formats section of the SigmaStudio help file.



Figure 3. audioMode Control

Record Mode A (**REC A**) or Record Mode B (**REC B**) can be selected by typing 0 or 1 into the **REC\_Coeff** cell in the default 28.0 format (see Figure 4).



Figure 4. REC\_Coeff Control

The playback (analog) output volume can be adjusted using the **slewwol** cell. Click and drag the slider to select a value (see Figure 5).

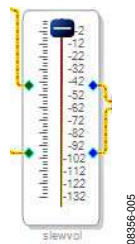

Figure 5. slewwol Control

Click on the slider to type the value in directly (see Figure 6).

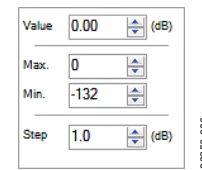

Figure 6. slewwol Control Direct Value Entry

Click the **dmute** cell to disable the record (digital) output (see Figure 7). A check corresponds to a mute setting.

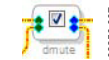

Figure 7. dmute Control

Click the **amute** cell to disable the playback (analog) output (see Figure 8). A check corresponds to a mute setting.



Figure 8. amute Control

To manually toggle the GPIO output, type a value into the **GPIO** cell (see Figure 9). This value is in 5.23 format. More information on 5.23 and other numeric formats can be found in the Numeric Formats section of the SigmaStudio help file.



Figure 9. GPIO Control

**Table 2. Main Page Control Settings**

Setting Name	Description	Default	Control Type
audioMode	Record/playback selection	0	Function selection
REC_Coeff	Selects REC A or REC B path	0	Function selection
slewwol	Analog volume control with slew	0 dB	Processing parameter
dmute	Digital output mute using slew	Enabled	Processing parameter
amute	Analog output mute using slew	Enabled	Processing parameter
GPIO	Sets the GPIO pin high/low (active high)	0	Processing parameter

**Parameters**

The main page parameters are stored in RAM, as outlined in Table 3. These addresses can be directly accessed and modified via the control port of the ADAU1381.

**Table 3. Main Page Parameters**

Address	Cell Name	Parameter Name	Default Value	Function	Bytes	Sample Rate Dependent?
0x0009	audioMode	DCInpAlg1	0x00, 0x00, 0x00, 0x00	Set record/playback mode	4	No
0x000A	REC_Coeff	DCInpAlg3	0x00, 0x00, 0x00, 0x00	Set record mode A or B	4	No
0x000B	GPIO	DCInpAlg4	0x00, 0x00, 0x00, 0x00	Set GPIO output flag	4	No
0x01B8	slewwol	GainS200AlgGrow1gain_target	0x00, 0x80, 0x00, 0x00	Analog output volume control	4	No
0x07FA, 0x07FB	slewwol	GainS200AlgGrow1alpha	0x00, 0x7F, 0xF2, 0x59, 0x00, 0x00, 0x0D, 0xA7	Slew rate for analog volume control	8	Yes
0x01B6	dmute	MuteSWLinSlewAlg1mute	0x00, 0x00, 0x00, 0x00	Mute digital (record) output	4	No
0x01B7	dmute	MuteSWLinSlewAlg1step	0x00, 0x00, 0x40, 0x00	Slew rate for digital mute	4	Yes
0x01BA	amute	MuteSWLinSlewAlg2mute	0x00, 0x00, 0x00, 0x00	Mute analog (playback) output	4	No
0x01BB	amute	MuteSWLinSlewAlg2step	0x00, 0x00, 0x40, 0x00	Slew rate for analog mute	4	Yes

WIND NOISE REDUCTION PAGE

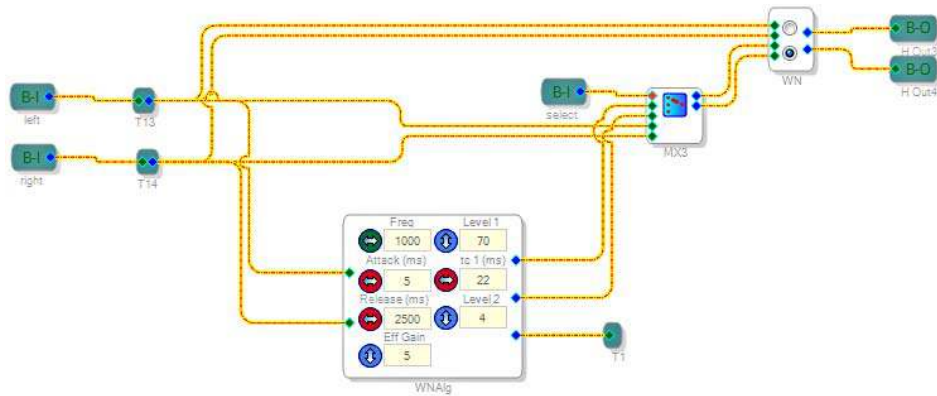

Figure 10. Wind Noise Reduction Page

Description

The wind noise reduction page houses the wind noise reduction algorithm, which uses two microphones to detect and filter wind noise from the audio signal. Wind noise can easily overwhelm an audio recording; this reduction algorithm can be used to lower the effect and increase the clarity of the signal to be recorded. The algorithm works by detecting the presence of wind noise and smoothly enabling or disabling a high-pass filter that removes the noise from the signal. Much of the wind noise that the microphones pick up is at low frequencies; therefore, the cutoff frequency of the high-pass filter should be adjusted to adequately remove the unwanted noise.

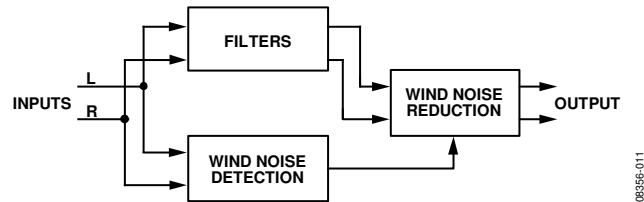

Figure 11. Wind Noise Reduction Block Diagram

Routing and Bypass

The wind noise reduction processing path is automatically enabled on the multiplexer (MX3) when the sound engine is put into either Record Mode A or Record Mode B. When in playback mode, this multiplexer bypasses the wind noise reduction algorithm. The switch on this page (WN) can be used to manually bypass the wind noise reduction, even in the record modes, if desired.

Controls

Three controls are recommended for in-system tuning: frequency (Freq), Level 1, and Level 2.

The frequency control sets the detector filters. This parameter should be tuned so that wind noise is removed, but the desired audio signal is preserved. The frequency parameter should be tuned while the system is presented with a constant wind noise,

such as from a fan blowing across, not directly onto, the microphones. The value can be entered by clicking the up/down arrows or by entering text directly in the box.

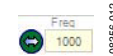

Figure 12. Freq Control

Level 1 should be tuned while turning the wind source on and off and simultaneously tuning the parameter setting between 0 and 100. The Level 1 setting is recommended to be between 60 and 90, but this varies depending on the application. The value can be entered by clicking the up/down arrows or by entering text directly in the box.



Figure 13. Level 1 Control

Level 2 should be tuned in the same way as Level 1; its settings range from 0 to 15, with 0 being for strong wind noise and 15 being for a signal with a weak wind noise component. The value can be entered by clicking the up/down arrows or by entering text directly in the box.



Figure 14. Level 2 Control

The WN switch manually enables or bypasses the algorithm independently of multiplexer MX3, which allows the algorithm to be disabled even when a record mode is active. The switch can be changed by clicking on the appropriate radio button.

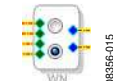

Figure 15. WN Control

**Table 4. Wind Noise Reduction Page Control Settings**

Setting Name	Description	Default	Control Type
Freq	High-pass filter setting	1000	Tune
Attack (ms)	Wind noise reduction effect attack time	5	Use default
Release (ms)	Wind noise reduction effect release time	2500	Use default
Eff Gain	Effect gain	5	Use default
tc 1 (ms)	Time constant	22	Use default
Level 1	Level of wind noise reduction	70	Tune
Level 2	Wind noise strength (0 = strong, 15 = weak)	4	Tune
WN Switch Bypass	Switch to disable algorithm	Enable algorithm	Function selection
MX3 Mux Bypass	Switch to bypass algorithm (via multiplexer)	Enable algorithm	Function selection

**Parameters**

The wind noise reduction page parameters are stored in RAM, as outlined in Table 5. These addresses can be directly accessed and modified via the control port of the ADAU1381.

**Table 5. Wind Noise Reduction Page Parameters**

Address	Cell Name	Parameter Name	Default Value	Function	Bytes	Sample Rate Dependent?
0x0011	WNAIlg	WindNoiseAlg2F11	0x00, 0xE8, 0x5D, 0x19	Frequency and effect gain parameters	4	Yes
0x0012	WNAIlg	WindNoiseAlg2F12	0xFF, 0x95, 0xA1, 0x9C	Frequency and effect gain parameters	4	Yes
0x0013	WNAIlg	WindNoiseAlg2F20	0x00, 0x00, 0x80, 0x53	Frequency and effect gain parameters	4	Yes
0x0014	WNAIlg	WindNoiseAlg2F21	0x00, 0x01, 0x00, 0xA6	Frequency and effect gain parameters	4	Yes
0x0015	WNAIlg	WindNoiseAlg2F30	0x00, 0xE8, 0xD0, 0x3A	Frequency and effect gain parameters	4	Yes
0x0016	WNAIlg	WindNoiseAlg2F31	0xFE, 0x2E, 0x5F, 0x8D	Frequency and effect gain parameters	4	Yes
0x0017	WNAIlg	WindNoiseAlg2F42	0x00, 0x80, 0x00, 0x00	Frequency and effect gain parameters	4	Yes
0x0018	WNAIlg	WindNoiseAlg2tc1	0x00, 0x00, 0x20, 0x00	Time constant 1 (ms)	4	Yes
0x0019	WNAIlg	WindNoiseAlg2tc11	0x00, 0x7F, 0xE0, 0x00	Time constant 1 (ms)	4	Yes
0x001A	WNAIlg	WindNoiseAlg2tc2	0x00, 0x00, 0x20, 0x00	Time constant 2 (ms)	4	Yes
0x001B	WNAIlg	WindNoiseAlg2tc22	0x00, 0x7F, 0xE0, 0x00	Time constant 2 (ms)	4	Yes
0x001C	WNAIlg	WindNoiseAlg2Level1	0x00, 0x59, 0x99, 0x9A	Level 1	4	No
0x001D	WNAIlg	WindNoiseAlg2Level2	0x00, 0x08, 0x00, 0x00	Level 2	4	No
0x001E	WNAIlg	WindNoiseAlg2attack	0x00, 0x00, 0x80, 0x00	Attack (ms)	4	Yes
0x001F	WNAIlg	WindNoiseAlg2release	0x00, 0x00, 0x00, 0x40	Release (ms)	4	Yes
0x0020	WN	stereomux1940ns40	0x00, 0x00, 0x00, 0x00	On/off (burst write Address 0x0020 and Address 0x0021 together)	4	No
0x0021	WN	stereomux1940ns41	0x00, 0x80, 0x00, 0x00	On/off (burst write Addresses 0x0020 and Address 0x0021 together)	4	No

**ENHANCED STEREO CAPTURE PAGE**

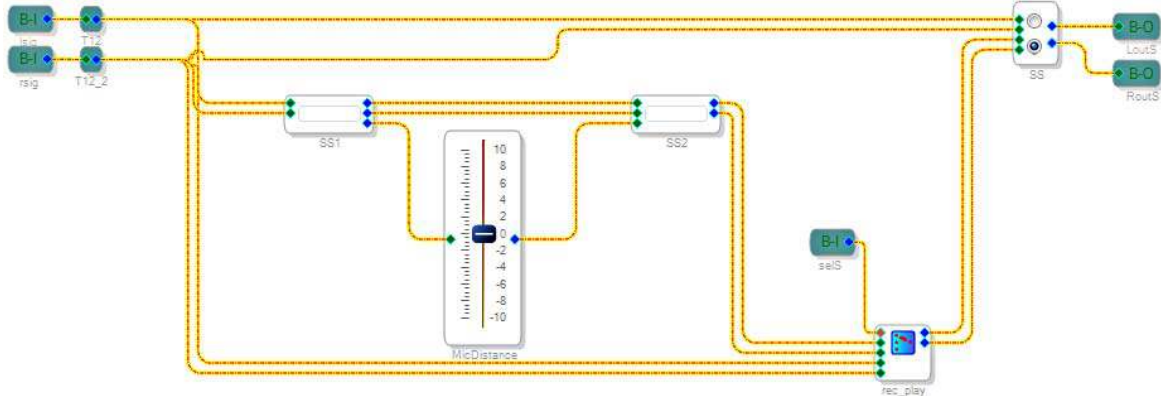

Figure 16. Enhanced Stereo Capture Page

**Description**

The enhanced stereo capture (ESC) algorithm takes a stereo record signal and creates a wider stereo image. ESC is used as a recording algorithm to capture an enhanced stereo image from two closely spaced microphones.

The ESC algorithm takes two input signals from two closely spaced microphones. The algorithm separates these two signals and widens the stereo image. The result is a perceived widened stereo image as if the audio was captured by microphones with greater left/right separation. ESC is based on proprietary filtering and a stereo balance gain that adjusts how much stereo effect is achieved in the algorithm.

**Routing and Bypass**

The enhanced stereo capture path is automatically enabled on the mux (**rec\_play**) when the sound engine is put into either **REC A** or **REC B**. When in playback mode, the mux bypasses the wind noise reduction algorithm. The switch on this page (**SS**) can be used to bypass the enhanced stereo capture, even in the record modes, if desired.

**Controls**

The **MicDistance** control can be set from -10 to +10, with a default value of 0 (see Figure 17). This control determines the sensitivity of the ESC algorithm and directly affects the level of stereo enhancement perceived in the recorded signal. Increasing the enhancement too much may result in an unnatural quality in the recorded audio. This control may vary greatly depending on factors such as microphone selection, spacing, and housing. Therefore, it must be tuned to fit the needs of a specific design.

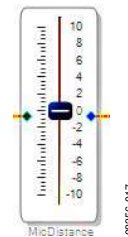

Figure 17. MicDistance Control

Right-click the slider to enter the value directly (see Figure 18).

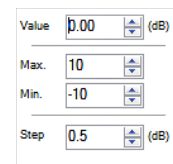

Figure 18. MicDistance Control Direct Value Entry

The **SS** switch allows the algorithm to be bypassed independently of the **rec\_play** multiplexer and the active audio mode. The switch can be changed by clicking on the appropriate radio button.



Figure 19. SS Control

**Table 6. ESC Page Control Settings**

Setting Name	Description	Default	Control Type
MicDistance	Control enhancement level	0	Tune
SS Switch Bypass	Switch to disable algorithm	Algorithm enabled	Function selection
rec_play Mux Bypass	Switch to bypass algorithm (via multiplexer)	Algorithm enabled	Function selection



**Parameters**

The enhanced stereo capture page parameters are stored in RAM, as outlined in Table 7. These addresses can be directly accessed and modified via the control port of the ADAU1381.

**Table 7. ESC Page Parameters**

Address	Cell Name	Parameter Name	Default Value	Function	Bytes	Sample Rate Dependent?
0x0029	MicDistance	Gain1940AlgNS1	0x00, 0x80, 0x00, 0x00	Gain setting related to the distance between microphones that enhances the perceived effect	4	No
0x002B	SS	stereomux1940ns30	0x00, 0x00, 0x00, 0x00	On/off (burst write Address0x002B and Address 0x002C together)	4	No
0x002C	SS	stereomux1940ns31	0x00, 0x80, 0x00, 0x00	On/off (burst write Address 0x002B and Address 0x002C together)	4	No
0x0023	Locked Cell	param1	0x00, 0xCA, 0x9A, 0x58	Locked parameter (generated by SigmaStudio)	4	Yes
0x0024	Locked Cell	param2	0x0F, 0x35, 0x65, 0xA8	Locked parameter (generated by SigmaStudio)	4	Yes
0x0025	Locked Cell	param3	0x00, 0x7F, 0xAA, 0xE7	Locked parameter (generated by SigmaStudio)	4	Yes
0x0026	Locked Cell	param4	0x00, 0x08, 0x38, 0x65	Locked parameter (generated by SigmaStudio)	4	Yes
0x0027	Locked Cell	param5	0x00, 0x00, 0x00, 0x00	Locked parameter (generated by SigmaStudio)	4	Yes
0x0028	Locked Cell	param6	0x00, 0x7B, 0x1A, 0x7E	Locked parameter (generated by SigmaStudio)	4	Yes

**EQUALIZATION FILTERS PAGE**

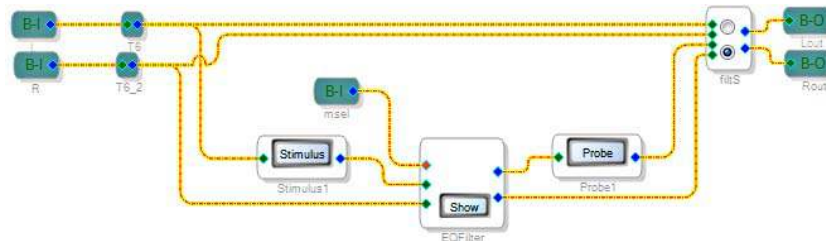

Figure 20. Equalization Filters Page

**Description**

Equalization (EQ) filters are used to tune the frequency response of the recorded or played back audio signal. The ADAU1381 sound engine includes three, six-band EQ paths, one for playback and the other two for different recording scenarios, such as music recording and voice.

Each EQ band is implemented as a double-precision biquad filter. These filters can be used in a wide variety of configurations, such as low-pass, high-pass, band-pass, parametric, shelving, peaking, tone control, and others.

**Routing and Bypass**

There are three, six-band EQ paths in the sound engine: one each for Record A (REC A), Record B (REC B), and Playback modes. Path 0 (top row) is the EQ filters for Record A (REC A), Path 1 (middle row) is the EQ filters for Record B (REC B), and Path 2 (bottom row) is the filters for the playback processing.

The appropriate path is automatically selected when the mode is selected on the main page.

The switch on this page (**filtS**) can be used to completely bypass the **EQFilter**, if desired.

**Controls**

Click **Show** on the **EQFilter** cell to configure the filter bands (see Figure 21).



Figure 21. EQFilter Control with Show Button

When **Show** is clicked, it displays a filter matrix with three rows and six columns (see Figure 22).



Figure 22. EQFilter Matrix

The first row represents the six bands of the Record A (**REC A**) mode, the second row represents the six bands of the Record B (**REC B**) mode, and the third row represents the six bands of the **Playback** mode.

Each button in the matrix contains a single second-order biquad filter. To individually tune a filter, click its corresponding button.

Clicking the menu at the top of the **General Filter Settings** window provides access to a large variety of filters, each with its own property pages and controls (see Figure 23 and Figure 24).

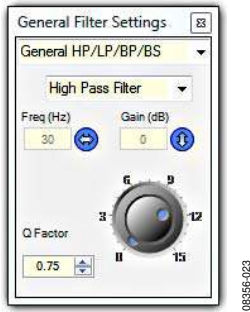

Figure 23. Individual Filter Band Settings

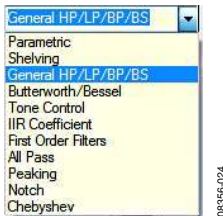

Figure 24. Filter Type Selection

More information on the various filters is available in the **Help** menu within SigmaStudio.

Click **Stimulus** and **Probe** to open the **Simulated Frequency Response** window (see Figure 25 and Figure 26).



Figure 25. Stimulus Button



Figure 26. Probe Button

The **Simulated Frequency Response** window displays a calculated frequency response for each of the filter bands. It shows only one EQ curve at a time, the one corresponding to the filter mode that was last edited.

By default, the EQ curve for Record A (**REC A**) mode is configured for voice recording (see Figure 27). The high-pass filter removes low frequencies that are not necessary for voice recording. The wide boost in the 150 Hz range amplifies the voice fundamental frequencies, and the narrow boost near 4 kHz increases vocal clarity.

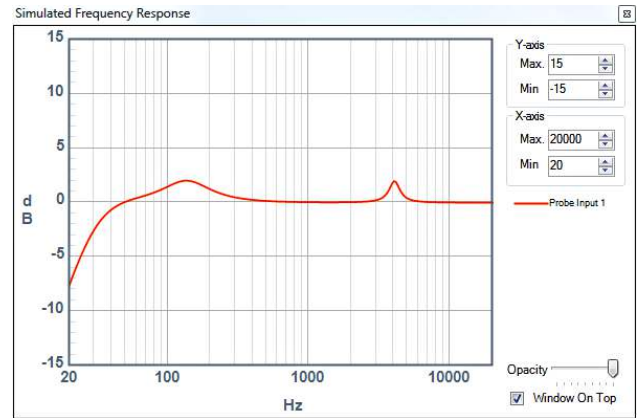

Figure 27. Default Record A (REC A) Mode EQ Curve

By default, the EQ curve for Record B (**REC B**) mode is configured for music and live concert recording (see Figure 28). The high-pass filter removes low frequency boom and rumble from a concert recording environment. The cut in the midbass range around 300 Hz helps to increase the perceived level of the bass. The low-pass filter on the high frequency range helps to reduce ringing caused by reflections in a loud concert environment.

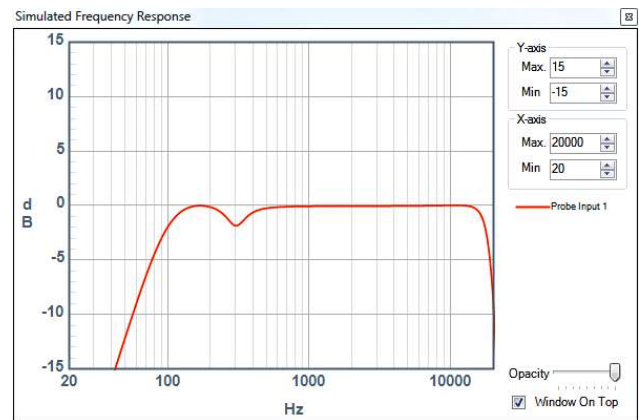

Figure 28. Default Record B (REC B) Mode EQ Curve

By default, the EQ curve for **Playback** mode is flat, which should be changed accordingly to compensate for nonlinearities due to the speaker design and housing (see Figure 29).

The default EQ curves are intended only as examples and should be specifically tuned for the target application system.

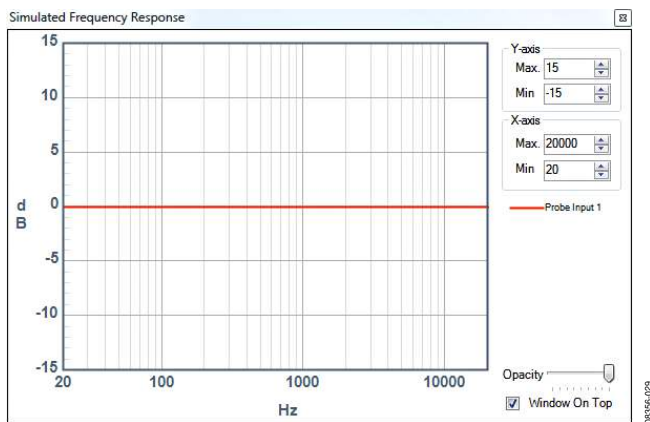

Figure 29. Default Playback Mode EQ Curve

Table 8. EQ Page Control Settings

Setting Name	Description	Default	Control Type
EQFilter	Three parallel six-band equalizers with independently controllable bands	Example curves for record and playback	Tune
filtS	Switch to disable algorithm	Algorithm enabled	Function selection

**Parameters**

The equalization filters page parameters are stored in RAM, as outlined in Table 9. These addresses can be directly accessed and modified via the control port of the ADAU1381.

Table 9. EQ Page Parameters

Address	Cell Name	Parameter Name	Default Value	Function	Bytes	Sample Rate Dependent?
0x002D 0x002E 0x002F 0x0030 0x0031	EQFilter	IndexSelMultBandAlg100b2	0x00, 0x7F, 0xAA, 0x50, 0xFF, 0x00, 0xAB, 0x60, 0x00, 0x7F, 0xAA, 0x50, 0xFF, 0x80, 0xAB, 0x20, 0x00, 0xFF, 0x54, 0x5F	Biquad F0, 0	20	Yes
0x0032 0x0033 0x0034 0x0035 0x0036	EQFilter	IndexSelMultBandAlg101b2	0x00, 0x7D, 0xBD, 0xAF, 0xFF, 0x02, 0x0A, 0x2E, 0x00, 0x80, 0x42, 0x4A, 0xFF, 0x82, 0x00, 0x07, 0x00, 0xFD, 0xF5, 0xD2	Biquad F0, 1	20	Yes
0x0037 0x0038 0x0039 0x003A 0x003B	EQFilter	IndexSelMultBandAlg102b2	0x00, 0x00, 0x00, 0x00, 0x00, 0x00, 0x00, 0x00, 0x00, 0x80, 0x00, 0x00, 0x00, 0x00, 0x00, 0x00, 0x00	Biquad F0, 2	20	Yes
0x003C 0x003D 0x003E 0x003F 0x0040	EQFilter	IndexSelMultBandAlg103b2	0x00, 0x00, 0x00, 0x00, 0x00, 0x00, 0x00, 0x00, 0x00, 0x80, 0x00, 0x00, 0x00, 0x00, 0x00, 0x00, 0x00	Biquad F0, 3	20	Yes

Address	Cell Name	Parameter Name	Default Value	Function	Bytes	Sample Rate Dependent?
0x0041 0x0042 0x0043 0x0044 0x0045	EQFilter	IndexSelMultBandAlg104b2	0x00, 0x71, 0xCB, 0x91, 0xFF, 0x2E, 0xCC, 0xE6, 0x00, 0x81, 0xA0, 0xD2, 0xFF, 0x8C, 0x93, 0x9D, 0x00, 0xD1, 0x33, 0x1A	Biquad F0, 4	20	Yes
0x0046 0x0047 0x0048 0x0049 0x004A	EQFilter	IndexSelMultBandAlg105b2	0x00, 0x00, 0x00, 0x00, 0x00, 0x00, 0x00, 0x00, 0x00, 0x80, 0x00, 0x00, 0x00, 0x00, 0x00, 0x00, 0x00, 0x00, 0x00, 0x00	Biquad F0, 5	20	Yes
0x004B 0x004C 0x004D 0x004E 0x004F	EQFilter	IndexSelMultBandAlg110b2	0x00, 0x7E, 0xFB, 0x24, 0xFF, 0x02, 0x09, 0xB7, 0x00, 0x7E, 0xFB, 0x24, 0xFF, 0x82, 0x06, 0xEE, 0x00, 0xFD, 0xF3, 0x80	Biquad F1, 0	20	Yes
0x0050 0x0051 0x0052 0x0053 0x0054	EQFilter	IndexSelMultBandAlg111b2	0x00, 0x7D, 0xEB, 0x86, 0xFF, 0x02, 0x83, 0x95, 0x00, 0x7F, 0xC2, 0xF7, 0xFF, 0x82, 0x51, 0x83, 0x00, 0xFD, 0x7C, 0x6B	Biquad F1, 1	20	Yes
0x0055 0x0056 0x0057 0x0058 0x0059	EQFilter	IndexSelMultBandAlg112b2	0x00, 0x00, 0x00, 0x00, 0x00, 0x00, 0x00, 0x00, 0x00, 0x80, 0x00, 0x00, 0x00, 0x00, 0x00, 0x00, 0x00, 0x00, 0x00, 0x00	Biquad F1, 2	20	Yes
0x005A 0x005B 0x005C 0x005D 0x005E	EQFilter	IndexSelMultBandAlg113b2	0x00, 0x00, 0x00, 0x00, 0x00, 0x00, 0x00, 0x00, 0x00, 0x80, 0x00, 0x00, 0x00, 0x00, 0x00, 0x00, 0x00, 0x00, 0x00, 0x00	Biquad F1, 3	20	Yes
0x005F 0x0060 0x0061 0x0062 0x0063	EQFilter	IndexSelMultBandAlg114b2	0x00, 0x00, 0x00, 0x00, 0x00, 0x00, 0x00, 0x00, 0x00, 0x80, 0x00, 0x00, 0x00, 0x00, 0x00, 0x00, 0x00, 0x00, 0x00, 0x00	Biquad F1, 4	20	Yes
0x0064 0x0065 0x0066 0x0067 0x0068	EQFilter	IndexSelMultBandAlg115b2	0x00, 0x4A, 0x91, 0x00, 0x00, 0x95, 0x22, 0x00, 0x00, 0x4A, 0x91, 0x00, 0xFF, 0xD1, 0x47, 0xB1, 0xFF, 0x84, 0x74, 0x4F	Biquad F1, 5	20	Yes
0x0069 0x006A 0x006B 0x006C 0x006D	EQFilter	IndexSelMultBandAlg120b2	0x00, 0x00, 0x00, 0x00, 0x00, 0x00, 0x00, 0x00, 0x00, 0x80, 0x00, 0x00, 0x00, 0x00, 0x00, 0x00, 0x00, 0x00, 0x00, 0x00	Biquad F2, 0	20	Yes
0x006E 0x006F 0x0070 0x0071 0x0072	EQFilter	IndexSelMultBandAlg121b2	0x00, 0x00, 0x00, 0x00, 0x00, 0x00, 0x00, 0x00, 0x00, 0x80, 0x00, 0x00, 0x00, 0x00, 0x00, 0x00, 0x00, 0x00, 0x00, 0x00	Biquad F2, 1	20	Yes

Address	Cell Name	Parameter Name	Default Value	Function	Bytes	Sample Rate Dependent?
0x0073 0x0074 0x0075 0x0076 0x0077	EQFilter	IndexSelMultBandAlg122b2	0x00, 0x00, 0x00, 0x00, 0x00, 0x00, 0x00, 0x00, 0x00, 0x80, 0x00, 0x00, 0x00, 0x00, 0x00, 0x00, 0x00, 0x00, 0x00, 0x00	Biquad F2, 2	20	Yes
0x0078 0x0079 0x007A 0x007B 0x007C	EQFilter	IndexSelMultBandAlg123b2	0x00, 0x00, 0x00, 0x00, 0x00, 0x00, 0x00, 0x00, 0x00, 0x80, 0x00, 0x00, 0x00, 0x00, 0x00, 0x00, 0x00, 0x00, 0x00, 0x00	Biquad F2, 3	20	Yes
0x007D 0x007E 0x007F 0x0080 0x0081	EQFilter	IndexSelMultBandAlg124b2	0x00, 0x00, 0x00, 0x00, 0x00, 0x00, 0x00, 0x00, 0x00, 0x80, 0x00, 0x00, 0x00, 0x00, 0x00, 0x00, 0x00, 0x00, 0x00, 0x00	Biquad F2, 4	20	Yes
0x0082 0x0083 0x0084 0x0085 0x0086	EQFilter	IndexSelMultBandAlg125b2	0x00, 0x00, 0x00, 0x00, 0x00, 0x00, 0x00, 0x00, 0x00, 0x80, 0x00, 0x00, 0x00, 0x00, 0x00, 0x00, 0x00, 0x00, 0x00, 0x00	Biquad F2, 5	20	Yes
0x008E	filtS	stereomux1940ns10	0x00, 0x00, 0x00, 0x00	On/off (burst write Address 0x008E and Address 0x008F together)	4	No
0x008F	filtS	stereomux1940ns11	0x00, 0x80, 0x00, 0x00	On/off (burst write Address 0x008E and Address 0x008F together)	4	No

DUAL-BAND COMPRESSION PAGE

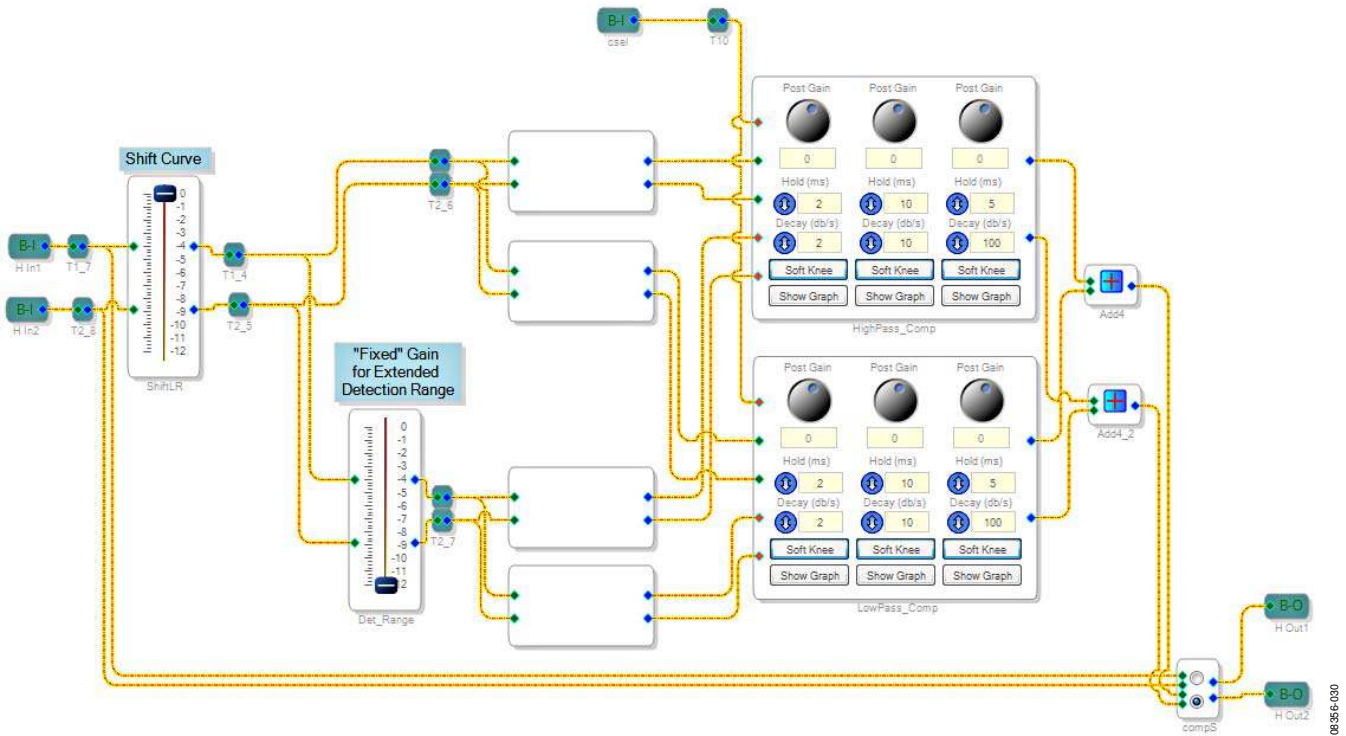

Figure 30. Dual-Band Compression Page

Description

The dual-band compression page contains dynamic processors designed to alter the dynamic range of the audio signal during record or playback. To provide high audio quality, the input signal is sent into a crossover network that divides it into high and low bands. Each band is detected and processed individually. The end result is that a sudden peak in one band (for example, a kick drum in the low band) will not cause a dip in the overall signal level.

Available Curves

By default, the record modes are configured with an automatic level control (ALC) curve, and the playback mode is configured with a standard compressor curve with a threshold of  $-6$  dB and a ratio of 2:1. The Record A (REC A) mode curve is an example of hard ALC compression (see Figure 31), and the Record B (REC B) mode curve is an example of smoothed ALC compression (see Figure 32). The playback mode compressor curve has moderate compression starting at a threshold of  $-8$  dB (see Figure 33). These default curves are intended only to be examples. The desired curve varies greatly depending on the application and other factors in the system. Therefore, unique curves should be created during the tuning process.

Figure 31, Figure 32, and Figure 33 show examples of compressor curves. The curves represent a transfer function, with the horizontal axis representing input in dB and the vertical axis representing the resulting output in dB.

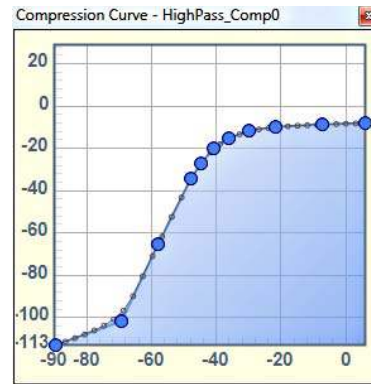

Figure 31. Default Record A (REC A) Mode Compressor Curve

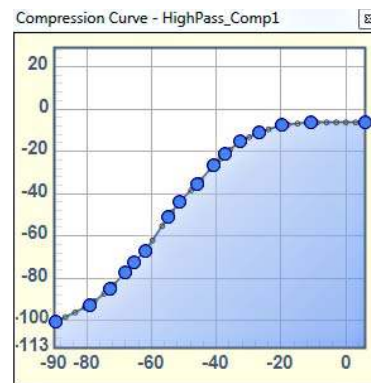

Figure 32. Default Record B (REC B) Mode Compressor Curve

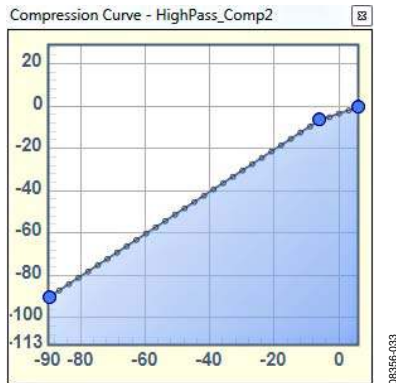

Figure 33. Default Playback Mode Compressor Curve

**Curve Shift**

The compressor curves can be shifted to the right using the **ShiftLR** control. This changes the input gain of the audio and detects signals routed to the compressor. The default value of 0 dB represents no shift from the original curve. Decreasing this value translates the compressor curves directly to the right by a corresponding amount. Note that there is no graphical difference shown on the compressor curve graphs, but the compressor curve points effectively shift directly to the right as the value of the slider decreases. The maximum shift allowed is 12 dB.

For a classic compression curve (linear compression ratio for low amplitudes and a ratio greater than 1 after a certain threshold), the **ShiftLR** control effectively increases the threshold value. The **ShiftLR** control allows a curve to be shifted at run time without requiring a download of new compression table parameters via the control port.

Figure 34 shows an example of curve shift being applied to an example compression curve with a gate below -80 dB, a linear transfer function between -80 dB and -28 dB, and a compression ratio of 2:1 for input amplitudes greater than -28 dB. The example curve is shown furthest to the left. Shifted curves for -3 dB, -6 dB, -9 dB, and -12 dB are shown to the right of the example curve. For all shifted curves, the compression threshold remains constant, but the gate threshold changes. The output gain for the linear section of the input range decreases as the curve shifts to the right.

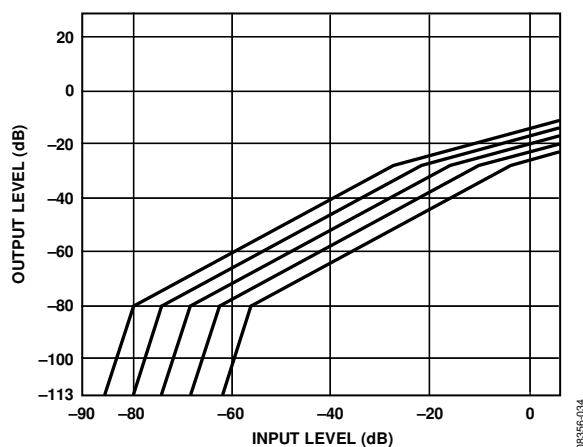

Figure 34. Curve Shift L/R Example

**Detection Range Shift**

The detection range control shifts the range over which the compressor operates. The algorithm typically handles inputs ranging from -90 dB to +6 dB. Any inputs outside of this range have a linear input-to-output relationship, effectively ignoring the compression curve. In applications where inputs to the compressor greater than 6 dB are expected, the detection range can be shifted to accommodate the input signal range. The default shift of -12 dB changes the detection range's lower bound to -78 dB and its upper bound to +18 dB. This curve shift must correspond to the compressors Adjust Gain Curve setting, shown in Figure 39.

The compression curve displayed in the compression curve graph represents a detection range shift of 0 dB. Decreasing the detection range effectively shifts the curve upward and to the right.

The detection range shift should be determined during system tuning and should not be altered when the system is in operation.

Figure 35 shows an example of detection range shift being applied to an example compression curve with a gate below -80 dB, a linear transfer function between -80 dB and -28 dB, and a compression ratio of 2:1 for input amplitudes greater than -28 dB. The example curve is shown furthest to the bottom and the left. Shifted curves for -3 dB, -6 dB, -9 dB, and -12 dB are shown above and to the right of the example curve. For all shifted curves, both the compression and gate thresholds increase, but the linear section of the input range remains linear.

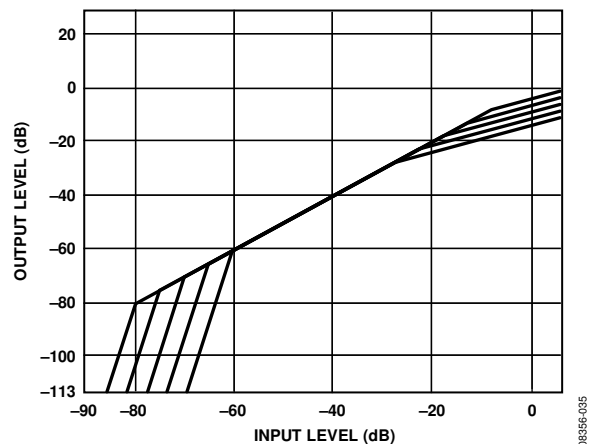

Figure 35. Detection Range Shift Example

**Routing and Bypass**

The dual-band compression algorithm is enabled by default in all audio modes. The **compS** switch allows the dual-band compressor to be bypassed manually.

**Controls**

The **ShiftLR** control shifts the compression curve horizontally. The slider can be dragged to change the value (see Figure 36). The default value of 0 dB indicates that the transfer function displayed in the compression curve editor matches the processing in the sound engine. Decreasing the value of the control shifts the curve to the right.

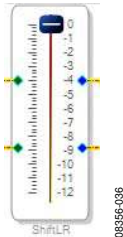

Figure 36. ShiftLR Control

Right-click the slider to type the value in directly (see Figure 37).

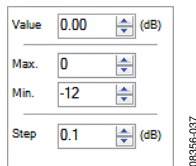

Figure 37. ShiftLR Control Direct Value Entry

The **Det\_Range** control shifts the compression curve diagonally (see Figure 38). The **Det\_Range** value can be controlled by dragging the slider or by entering the value manually by right-clicking the slider. The **Det\_Range** control is only intended to take on the following values: 0 dB, -3 dB, -6 dB, -9 dB, and -12 dB.

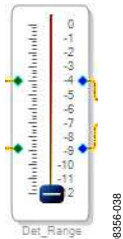

Figure 38. Det\_Range Control

When the detection range is modified, the compressors must also be configured to match. By default, the compressors are configured for a detection range shift of -12 dB. To change the compressor detection range, click on a compressor cell, select the **Adjust Gain Curve** option, and select the value matching the setting of the **Det\_Range** control (see Figure 39). Complete this process for both the high-band and low-band compressors.

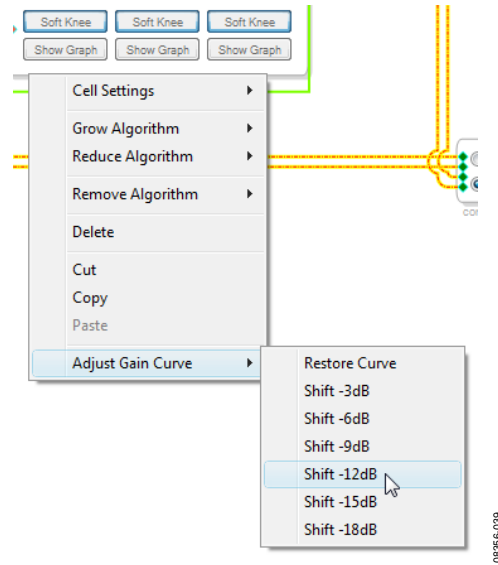

Figure 39. Changing the Detection Curve of a Compressor

Each frequency band (low and high) is fed into a stereo compressor matrix (see Figure 40). Each matrix contains three compressors, one for each audio mode. The left column corresponds to Record A (**REC A**) mode, the center column corresponds to Record B (**REC B**) mode, and the right column corresponds to **Playback** mode.

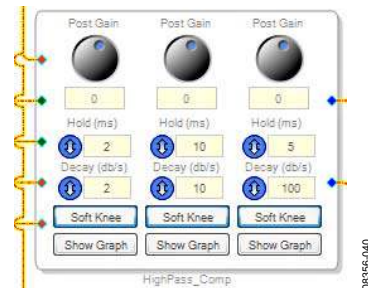

Figure 40. HighPass\_Comp Control

Each compressor column contains a **Post Gain** control that adjusts the amount of gain applied to the signal at the output of the compressor (see Figure 41).



Figure 41. Post Gain Control

The **Hold (ms)** control sets the duration that the gain reduction ratio of the compressor is held after it is set by the input signal (see Figure 42).



Figure 42. Hold (ms) Control



The **Decay (dB/s)** control sets the speed by which the gain reduction ratio decays after the hold duration expires (see Figure 43).



Figure 43. Decay (dB/s) Control

Click the **Soft Knee** button to smooth the corners (also known as knees) of the **Compression Curve** (see Figure 44).



Figure 44. Soft Knee Button

Click the **Show Graph** button to display the **Compression Curve** graphical editor (see Figure 45).



Figure 45. Show Graph Button

The **Compression Curve** editor displays a graphical representation of the input/output gain transfer function, which is a curve with 33 points (see Figure 46). The horizontal axis represents the input level, and the vertical axis represents the output level. Each large point can be dragged to a new position on the graph.

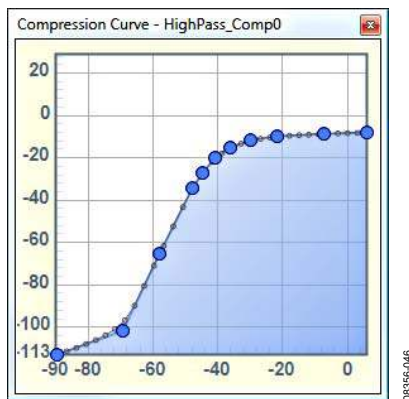

Figure 46. Compression Curve Editor

Click on a point within the graph to display the **Compression Curve Point Option** menu. This is where large points can be added, removed, or fine-tuned (see Figure 47).

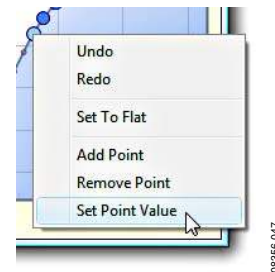

Figure 47. Compression Curve Point Option Menu

Click on a set point value to display a dialog box where the coordinates of the point can be entered manually (see Figure 48).

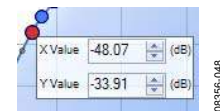

Figure 48. Compression Curve Point Direct Value Entry

The **compS** switch allows the dual-band compressors to be bypassed (see Figure 49). Click on the appropriate radio button to change the switch.



Figure 49. compS Control

Table 10. Dual-Band Compression Page Control Settings

Setting Name	Description	Default	Control Type
ShiftLR	Shift curve left/right	0	Tune
Det_Range	Fixed gain for extended detection range	-12	Tune
CrossHi	Crossover for high frequencies	N/A	Locked
CrossLo	Crossover for low frequencies	N/A	Locked
HiDet Filter	Filter for high frequency detector	N/A	Locked
LoDet Filter	Filter for low frequency detector	N/A	Locked
<b>HIGH-PASS COMPRESSOR</b>			
Post Gain (dB)	Gain applied to the output of the compressor	0	Tune
Hold (ms)	Duration that the gain reduction ratio of the compressor is held after it is set by the input signal	2	Tune
Decay (dB/s)	Speed that the gain reduction ratio of the compressor decreases after the hold time expires	2	Tune
Soft Knee	Smooths the compression curve	Active	Tune
Graph Editor	Graphical entry of compression curve (input/output gain transfer function)	Default compression curves	Tune

Setting Name	Description	Default	Control Type
LOW-PASS COMPRESSOR			
Post Gain (dB)	Gain applied to the output of the compressor	0	Tune
Hold (ms)	Duration that the gain reduction ratio of the compressor is held after it is set by the input signal	2	Tune
Decay (dB/s)	Speed that the gain reduction ratio of the compressor decreases after the hold time expires	2	Tune
Soft Knee	Smooths the compression curve	Active	Tune
Graph Editor	Graphical entry of compression curve (input/output gain transfer function)	Default compression curves	Tune
compS	Switch/mux bypass	Algorithm enabled	Function selection

### Parameters

The dual-band compression page parameters are stored in RAM, as outlined in Table 11. These addresses can be directly accessed and modified via the control port of the ADAU1381.

**Table 11. Dual-Band Compression Page Parameters**

Address	Cell Name	Parameter Name	Default Value	Function	Bytes	Sample Rate Dependent?
0x0090	ShiftLR	Gain1940AlgNS4	0x00, 0x80, 0x00, 0x00	Shift curve left/right; Address 0x0090 and Address 0x0091 must contain the same value	4	No
0x0091	ShiftLR	Gain1940AlgNS5	0x00, 0x80, 0x00, 0x00	Shift curve left/right; Address 0x0090 and Address 0x0091 must contain the same value	4	No
0x0092	Det_Range	Gain1940AlgNS3	0x00, 0x20, 0x26, 0xF3	On/off (burst write Address 0x0092 and Address 0x0093 together)	4	No
0x0093	Det_Range	Gain1940AlgNS2	0x00, 0x20, 0x26, 0xF3	On/off (burst write Address 0x0092 and Address 0x0093 together)	4	No
0x00A2	CrossHi	EQwSubDualDP32B1	0x00, 0x7B, 0xEB, 0x74	Crossover HPF filter coefficient	4	Yes
0x00A3	CrossHi	EQwSubDualDP31B1	0x0F, 0x08, 0x29, 0x18	Crossover HPF filter coefficient	4	Yes
0x00A4	CrossHi	EQwSubDualDP30B1	0x00, 0x7B, 0xEB, 0x74	Crossover HPF filter coefficient	4	Yes
0x00A5	CrossHi	EQwSubDualDP32A1	0x0F, 0x88, 0x07, 0xC9	Crossover HPF filter coefficient	4	Yes
0x00A6	CrossHi	EQwSubDualDP31A1	0x00, 0xF7, 0xB5, 0x9A	Crossover HPF filter coefficient	4	Yes
0x00A7	CrossHi	EQwSubDualDP32B2	0x00, 0x7B, 0xEB, 0x74	Crossover HPF filter coefficient	4	Yes
0x00A8	CrossHi	EQwSubDualDP31B2	0x0F, 0x08, 0x29, 0x18	Crossover HPF filter coefficient	4	Yes
0x00A9	CrossHi	EQwSubDualDP30B2	0x00, 0x7B, 0xEB, 0x74	Crossover HPF filter coefficient	4	Yes
0x00AA	CrossHi	EQwSubDualDP32A2	0x0F, 0x88, 0x07, 0xC9	Crossover HPF filter coefficient	4	Yes
0x00AB	CrossHi	EQwSubDualDP31A2	0x00, 0xF7, 0xB5, 0x9A	Crossover HPF filter coefficient	4	Yes

Address	Cell Name	Parameter Name	Default Value	Function	Bytes	Sample Rate Dependent?
0x0094	CrossLo	EQwSubDualDP42B1	0x00, 0x00, 0x10, 0xA7	Crossover LPF filter coefficient	4	Yes
0x0095	CrossLo	EQwSubDualDP41B1	0x00, 0x00, 0x21, 0x4E	Crossover LPF filter coefficient	4	Yes
0x0096	CrossLo	EQwSubDualDP40B1	0x00, 0x00, 0x10, 0xA7	Crossover LPF filter coefficient	4	Yes
0x0097	CrossLo	EQwSubDualDP42A1	0x0F, 0x88, 0x07, 0xC9	Crossover LPF filter coefficient	4	Yes
0x0098	CrossLo	EQwSubDualDP41A1	0x00, 0xF7, 0xB5, 0x9A	Crossover LPF filter coefficient	4	Yes
0x0099	CrossLo	EQwSubDualDP42B2	0x00, 0x00, 0x10, 0xA7	Crossover LPF filter coefficient	4	Yes
0x009A	CrossLo	EQwSubDualDP41B2	0x00, 0x00, 0x21, 0x4E	Crossover LPF filter coefficient	4	Yes
0x009B	CrossLo	EQwSubDualDP40B2	0x00, 0x00, 0x10, 0xA7	Crossover LPF filter coefficient	4	Yes
0x009C	CrossLo	EQwSubDualDP42A2	0x0F, 0x88, 0x07, 0xC9	Crossover LPF filter coefficient	4	Yes
0x009D	CrossLo	EQwSubDualDP41A2	0x00, 0xF7, 0xB5, 0x9A	Crossover LPF filter coefficient	4	Yes
0x00BE	HiDet_Filter	EQwSubDualDP52B1	0x00, 0x7D, 0x44, 0xE0	Crossover HPF detection path filter coefficient	4	Yes
0x00BF	HiDet_Filter	EQwSubDualDP51B1	0x0F, 0x05, 0x76, 0x40	Crossover HPF detection path filter coefficient	4	Yes
0x00C0	HiDet_Filter	EQwSubDualDP50B1	0x00, 0x7D, 0x44, 0xE0	Crossover HPF detection path filter coefficient	4	Yes
0x00C1	HiDet_Filter	EQwSubDualDP52A1	0x0F, 0x85, 0x67, 0x55	Crossover HPF detection path filter coefficient	4	Yes
0x00C2	HiDet_Filter	EQwSubDualDP51A1	0x00, 0xFA, 0x7A, 0xD5	Crossover HPF detection path filter coefficient	4	Yes
0x00C3	HiDet_Filter	EQwSubDualDP52B2	0x00, 0x7D, 0x44, 0xE0	Crossover HPF detection path filter coefficient	4	Yes
0x00C4	HiDet_Filter	EQwSubDualDP51B2	0x0F, 0x05, 0x76, 0x40	Crossover HPF detection path filter coefficient	4	Yes
0x00C5	HiDet_Filter	EQwSubDualDP50B2	0x00, 0x7D, 0x44, 0xE0	Crossover HPF detection path filter coefficient	4	Yes
0x00C6	HiDet_Filter	EQwSubDualDP52A2	0x0F, 0x85, 0x67, 0x55	Crossover HPF detection path filter coefficient	4	Yes
0x00C7	HiDet_Filter	EQwSubDualDP51A2	0x00, 0xFA, 0x7A, 0xD5	Crossover HPF detection path filter coefficient	4	Yes
0x00B0	LoDet_Filter	EQwSubDualDP62B1	0x00, 0x00, 0x24, 0xE2	Crossover LPF detection path filter coefficient	4	Yes
0x00B1	LoDet_Filter	EQwSubDualDP61B1	0x00, 0x00, 0x49, 0xC4	Crossover LPF detection path filter coefficient	4	Yes

Address	Cell Name	Parameter Name	Default Value	Function	Bytes	Sample Rate Dependent?
0x00B2	LoDet_Filter	EQwSubDualDP60B1	0x00, 0x00, 0x24, 0xE2	Crossover LPF detection path filter coefficient	4	Yes
0x00B3	LoDet_Filter	EQwSubDualDP62A1	0x0F, 0x8B, 0xDA, 0xCC	Crossover LPF detection path filter coefficient	4	Yes
0x00B4	LoDet_Filter	EQwSubDualDP61A1	0x00, 0xF3, 0x91, 0xAC	Crossover LPF detection path filter coefficient	4	Yes
0x00B5	LoDet_Filter	EQwSubDualDP62B2	0x00, 0x00, 0x24, 0xE2	Crossover LPF detection path filter coefficient	4	Yes
0x00B6	LoDet_Filter	EQwSubDualDP61B2	0x00, 0x00, 0x49, 0xC4	Crossover LPF detection path filter coefficient	4	Yes
0x00B7	LoDet_Filter	EQwSubDualDP60B2	0x00, 0x00, 0x24, 0xE2	Crossover LPF detection path filter coefficient	4	Yes
0x00B8	LoDet_Filter	EQwSubDualDP62A2	0x0F, 0x8B, 0xDA, 0xCC	Crossover LPF detection path filter coefficient	4	Yes
0x00B9	LoDet_Filter	EQwSubDualDP61A2	0x00, 0xF3, 0x91, 0xAC	Crossover LPF detection path filter coefficient	4	Yes
0x00CC	HighPass_Comp	PeakDBCompLUTAlgPG30decay	0x00, 0x00, 0x00, 0x04	REC_Auto: decay	4	Yes
0x00CD	HighPass_Comp	PeakDBCompLUTAlgPG30hold	0x00, 0x00, 0x00, 0x60	REC_Auto: hold	4	Yes

Address	Cell Name	Parameter Name	Default Value	Function	Bytes	Sample Rate Dependent?
0x00CE 0x00CF 0x00D0 0x00D1 0x00D2 0x00D3 0x00D4 0x00D5 0x00D6 0x00D7 0x00D8 0x00D9 0x00DA 0x00DB 0x00DC 0x00DD 0x00DE 0x00DF 0x00E0 0x00E1 0x00E2 0x00E3 0x00E4 0x00E5 0x00E6 0x00E7 0x00E8 0x00E9 0x00EA 0x00EB 0x00EC 0x00ED 0x00EE	HighPass_Comp	PeakDBCompLUTAlgPG30tab	0x00, 0x05, 0x1A, 0x96, 0x00, 0x04, 0xB6, 0x9B, 0x00, 0x04, 0xAD, 0x54, 0x00, 0x05, 0x55, 0x55, 0x00, 0x08, 0x55, 0xC1, 0x00, 0x11, 0x6C, 0xA5, 0x00, 0x25, 0x0E, 0xD2, 0x00, 0x4D, 0x9C, 0x93, 0x00, 0xA0, 0x10, 0xF5, 0x01, 0x46, 0xB2, 0x33, 0x02, 0x80, 0x9F, 0x0A, 0x03, 0xF0, 0xCE, 0x62, 0x05, 0x54, 0x59, 0xF2, 0x05, 0xEF, 0xF5, 0xFC, 0x05, 0xBA, 0x65, 0x98, 0x05, 0x17, 0xAD, 0xEF, 0x04, 0x3A, 0x77, 0xC5, 0x03, 0x56, 0xDC, 0x88, 0x02, 0x8B, 0x2A, 0xC5, 0x01, 0xE7, 0x60, 0xA5, 0x01, 0x67, 0x06, 0x39, 0x01, 0x05, 0xD8, 0x28, 0x00, 0xBE, 0x7E, 0xE5, 0x00, 0x8A, 0x46, 0xF6, 0x00, 0x64, 0x17, 0x5B, 0x00, 0x48, 0x3E, 0xCA, 0x00, 0x34, 0x06, 0x48, 0x00, 0x25, 0x6A, 0x11, 0x00, 0x1A, 0xE6, 0xE6, 0x00, 0x13, 0x05, 0xC6, 0x00, 0x0D, 0x73, 0x73, 0x00, 0x09, 0x82, 0xE3, 0x00, 0x06, 0xB9, 0xBA	REC_Auto: compressor curve points	132	No
0x0138	HighPass_Comp	PeakDBCompLUTAlgPG30post_gain	0x00, 0x80, 0x00, 0x00	REC_Auto: post gain	4	No
0x00EF	HighPass_Comp	PeakDBCompLUTAlgPG31decay	0x00, 0x00, 0x00, 0x12	REC_Manual: decay	4	Yes
0x00F0	HighPass_Comp	PeakDBCompLUTAlgPG31hold	0x00, 0x00, 0x01, 0xE0	REC_Manual: hold	4	Yes

Address	Cell Name	Parameter Name	Default Value	Function	Bytes	Sample Rate Dependent?
0x00F1 0x00F2 0x00F3 0x00F4 0x00F5 0x00F6 0x00F7 0x00F8 0x00F9 0x00FA 0x00FB 0x00FC 0x00FD 0x00FE 0x00FF 0x0100 0x0101 0x0102 0x0103 0x0104 0x0105 0x0106 0x0107 0x0108 0x0109 0x010A 0x010B 0x010C 0x010D 0x010E 0x010F 0x0110 0x0111	HighPass_Comp	PeakDBCompLUTAlgPG31tab	0x00, 0x1D, 0xC7, 0xFA, 0x00, 0x1F, 0xA6, 0x78, 0x00, 0x24, 0xCD, 0xBF, 0x00, 0x2D, 0xB0, 0xDE, 0x00, 0x3A, 0x4E, 0x7F, 0x00, 0x47, 0xE3, 0x23, 0x00, 0x67, 0x41, 0xE8, 0x00, 0xA1, 0x64, 0x8B, 0x00, 0xF3, 0x71, 0x72, 0x01, 0x4B, 0x5C, 0x80, 0x01, 0x96, 0x84, 0x19, 0x01, 0xF9, 0x0D, 0x62, 0x02, 0x8A, 0xA7, 0xCA, 0x03, 0x24, 0x67, 0xA2, 0x03, 0x9A, 0x7A, 0x83, 0x03, 0xD1, 0x34, 0x62, 0x03, 0xA2, 0xBD, 0x15, 0x03, 0x3D, 0x07, 0x65, 0x02, 0xC9, 0xE3, 0xC3, 0x02, 0x4D, 0x52, 0x70, 0x01, 0xCE, 0xBA, 0xD0, 0x01, 0x5C, 0x48, 0xE1, 0x00, 0xFF, 0x34, 0xC9, 0x00, 0xB8, 0x8A, 0x49, 0x00, 0x83, 0xA5, 0x3C, 0x00, 0x5D, 0x40, 0x76, 0x00, 0x42, 0x04, 0x69, 0x00, 0x2E, 0xBC, 0x93, 0x00, 0x21, 0x16, 0x45, 0x00, 0x17, 0x65, 0x63, 0x00, 0x10, 0x8B, 0x23, 0x00, 0x0B, 0xB2, 0xB1, 0x00, 0x08, 0x45, 0x91	REC_Manual: compressor curve points	132	No
0x0139	HighPass_Comp	PeakDBCompLUTAlgPG31post_gain	0x00, 0x80, 0x00, 0x00	REC_Manual: post gain	4	No
0x0112	HighPass_Comp	PeakDBCompLUTAlgPG32decay	0x00, 0x00, 0x00, 0xB6	Speaker: decay	4	Yes
0x0113	HighPass_Comp	PeakDBCompLUTAlgPG32hold	0x00, 0x00, 0x00, 0xF0	Speaker: hold	4	Yes

Address	Cell Name	Parameter Name	Default Value	Function	Bytes	Sample Rate Dependent?
0x0114	HighPass_Comp	PeakDBCompLUTAlgPG32tab	0x00, 0x80, 0x00, 0x00,	Speaker: compressor curve points	132	No
0x0115			0x00, 0x80, 0x00, 0x00,			
0x0116			0x00, 0x80, 0x00, 0x00,			
0x0117			0x00, 0x80, 0x00, 0x00,			
0x0118			0x00, 0x80, 0x00, 0x00,			
0x0119			0x00, 0x80, 0x00, 0x00,			
0x011A			0x00, 0x80, 0x00, 0x00,			
0x011B			0x00, 0x80, 0x00, 0x00,			
0x011C			0x00, 0x80, 0x00, 0x00,			
0x011D			0x00, 0x80, 0x00, 0x00,			
0x011E			0x00, 0x80, 0x00, 0x00,			
0x011F			0x00, 0x80, 0x00, 0x00,			
0x0120			0x00, 0x80, 0x00, 0x00,			
0x0121			0x00, 0x80, 0x00, 0x00,			
0x0122			0x00, 0x80, 0x00, 0x00,			
0x0123			0x00, 0x80, 0x00, 0x00,			
0x0124			0x00, 0x80, 0x00, 0x00,			
0x0125			0x00, 0x80, 0x00, 0x00,			
0x0126			0x00, 0x80, 0x00, 0x00,			
0x0127			0x00, 0x80, 0x00, 0x00,			
0x0128			0x00, 0x80, 0x00, 0x00,			
0x0129			0x00, 0x80, 0x00, 0x00,			
0x012A			0x00, 0x7F, 0xF0, 0x61,			
0x012B			0x00, 0x7D, 0x6C, 0x21,			
0x012C			0x00, 0x75, 0x7A, 0x64,			
0x012D			0x00, 0x68, 0xDB, 0x84,			
0x012E			0x00, 0x5A, 0x4C, 0x32,			
0x012F			0x00, 0x4C, 0x3E, 0xA8,			
0x0130	0x00, 0x40, 0x26, 0xE7,					
0x0131	0x00, 0x2D, 0x5C, 0xBF,					
0x0132	0x00, 0x20, 0x13, 0x74,					
0x0133	0x00, 0x16, 0xAE, 0x60,					
0x0134	0x00, 0x10, 0x09, 0xBA					
0x013A	HighPass_Comp	PeakDBCompLUTAlgPG32post_gain	0x00, 0x80, 0x00, 0x00	Speaker: post gain	4	No
0x0140	LowPass_Comp	PeakDBCompLUTAlgPG40decay	0x00, 0x00, 0x00, 0x04	REC_Auto: decay	4	Yes
0x0141	LowPass_Comp	PeakDBCompLUTAlgPG40hold	0x00, 0x00, 0x00, 0x60	REC_Auto: hold	4	Yes

Address	Cell Name	Parameter Name	Default Value	Function	Bytes	Sample Rate Dependent?
0x0142 0x0143 0x0144 0x0145 0x0146 0x0147 0x0148 0x0149 0x014A 0x014B 0x014C 0x014D 0x014E 0x014F 0x0150 0x0151 0x0152 0x0153 0x0154 0x0155 0x0156 0x0157 0x0158 0x0159 0x015A 0x015B 0x015C 0x015D 0x015E 0x015F 0x0160 0x0161 0x0162	LowPass_Comp	PeakDBCompLUTAlgPG40tab	0x00, 0x05, 0x1A, 0x96, 0x00, 0x04, 0xB6, 0x9B, 0x00, 0x04, 0xAD, 0x54, 0x00, 0x05, 0x55, 0x55, 0x00, 0x08, 0x55, 0xC1, 0x00, 0x11, 0x6C, 0xA5, 0x00, 0x25, 0x0E, 0xD2, 0x00, 0x4D, 0x9C, 0x93, 0x00, 0xA0, 0x10, 0xF5, 0x01, 0x46, 0xB2, 0x33, 0x02, 0x80, 0x9F, 0x0A, 0x03, 0xF0, 0xCE, 0x62, 0x05, 0x54, 0x59, 0xF2, 0x05, 0xEF, 0xF5, 0xFC, 0x05, 0xBA, 0x65, 0x98, 0x05, 0x17, 0xAD, 0xEF, 0x04, 0x3A, 0x77, 0xC5, 0x03, 0x56, 0xDC, 0x88, 0x02, 0x8B, 0x2A, 0xC5, 0x01, 0xE7, 0x60, 0xA5, 0x01, 0x67, 0x06, 0x39, 0x01, 0x05, 0xD8, 0x28, 0x00, 0xBE, 0x7E, 0xE5, 0x00, 0x8A, 0x46, 0xF6, 0x00, 0x64, 0x17, 0x5B, 0x00, 0x48, 0x3E, 0xCA, 0x00, 0x34, 0x06, 0x48, 0x00, 0x25, 0x6A, 0x11, 0x00, 0x1A, 0xE6, 0xE6, 0x00, 0x13, 0x05, 0xC6, 0x00, 0x0D, 0x73, 0x73, 0x00, 0x09, 0x82, 0xE3, 0x00, 0x06, 0xB9, 0xBA	REC_Auto: compressor curve points	132	No
0x01AC	LowPass_Comp	PeakDBCompLUTAlgPG40post_gain	0x00, 0x80, 0x00, 0x00	REC_Auto: post gain	4	No
0x0163	LowPass_Comp	PeakDBCompLUTAlgPG41decay	0x00, 0x00, 0x00, 0x12	REC_Manual: decay	4	Yes
0x0164	LowPass_Comp	PeakDBCompLUTAlgPG41hold	0x00, 0x00, 0x01, 0xE0	REC_Manual: hold	4	Yes



Address	Cell Name	Parameter Name	Default Value	Function	Bytes	Sample Rate Dependent?
0x0165 0x0166 0x0167 0x0168 0x0169 0x016A 0x016B 0x016C 0x016D 0x016E 0x016F 0x0170 0x0171 0x0172 0x0173 0x0174 0x0175 0x0176 0x0177 0x0178 0x0179 0x017A 0x017B 0x017C 0x017D 0x017E 0x017F 0x0180 0x0181 0x0182 0x0183 0x0184 0x0185	LowPass_Comp	PeakDBCompLUTAlgPG41tab	0x00, 0x1D, 0xC7, 0xFA, 0x00, 0x1F, 0xA6, 0x78, 0x00, 0x24, 0xCD, 0xBF, 0x00, 0x2D, 0xB0, 0xDE, 0x00, 0x3A, 0x4E, 0x7F, 0x00, 0x47, 0xE3, 0x23, 0x00, 0x67, 0x41, 0xE8, 0x00, 0xA1, 0x64, 0x8B, 0x00, 0xF3, 0x71, 0x72, 0x01, 0x4B, 0x5C, 0x80, 0x01, 0x96, 0x84, 0x19, 0x01, 0xF9, 0x0D, 0x62, 0x02, 0x8A, 0xA7, 0xCA, 0x03, 0x24, 0x67, 0xA2, 0x03, 0x9A, 0x7A, 0x83, 0x03, 0xD1, 0x34, 0x62, 0x03, 0xA2, 0xBD, 0x15, 0x03, 0x3D, 0x07, 0x65, 0x02, 0xC9, 0xE3, 0xC3, 0x02, 0x4D, 0x52, 0x70, 0x01, 0xCE, 0xBA, 0xD0, 0x01, 0x5C, 0x48, 0xE1, 0x00, 0xFF, 0x34, 0xC9, 0x00, 0xB8, 0x8A, 0x49, 0x00, 0x83, 0xA5, 0x3C, 0x00, 0x5D, 0x40, 0x76, 0x00, 0x42, 0x04, 0x69, 0x00, 0x2E, 0xBC, 0x93, 0x00, 0x21, 0x16, 0x45, 0x00, 0x17, 0x65, 0x63, 0x00, 0x10, 0x8B, 0x23, 0x00, 0x0B, 0xB2, 0xB1, 0x00, 0x08, 0x45, 0x91	REC_Manual: compressor curve points	132	No
0x01AD	LowPass_Comp	PeakDBCompLUTAlgPG41post_gain	0x00, 0x80, 0x00, 0x00	REC_Manual: post gain	4	No
0x0186	LowPass_Comp	PeakDBCompLUTAlgPG42decay	0x00, 0x00, 0x00, 0xB6	Speaker: decay	4	Yes
0x0187	LowPass_Comp	PeakDBCompLUTAlgPG42hold	0x00, 0x00, 0x00, 0xF0	Speaker: hold	4	Yes



## SIGMASTUDIO TOOLS

### CHANGING SAMPLE RATE

To change the sampling rate of the system, complete the following steps:

1. Select a new sample rate from the menu in the toolbar (see Figure 50).

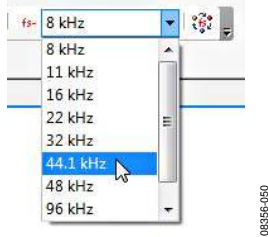

Figure 50. Sample Rate Menu

2. Click the **Set System Sampling Rate** button (see Figure 51) and click **Yes** when prompted to confirm (see Figure 52).

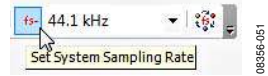

Figure 51. Set System Sampling Rate Button

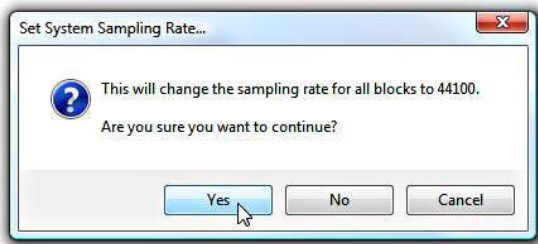

Figure 52. Set System Sampling Rate... Confirmation Window

3. If target hardware is connected to the PC, click the **Link-Compile-Download** button (see Figure 53) to download the new parameters to the hardware.



Figure 53. Link-Compile-Download Button

## CAPTURE WINDOW

The **Capture** window is visible by default when SigmaStudio is executed for the first time. Its visibility can be toggled in the **View** menu.

The **Capture** window displays all communications between the PC and the control port of the ADAU1381 (see Figure 54). It is a useful tool for debugging and monitoring communications.

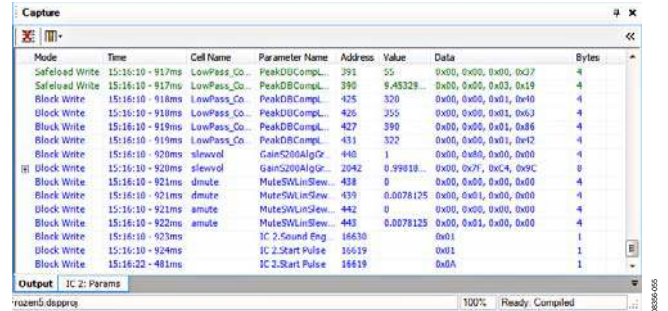

Figure 54. Capture Window

## PARAMETER VISUALIZATION WINDOW

Click the **IC 2: Params** tab at the bottom of the **Capture** window to open the **Parameter Visualization** window (see Figure 55). This window shows all parameter RAM values for the project in real-time. It does not display the values of the parameters stored in addresses higher than 0x01FF (Decimal 511).

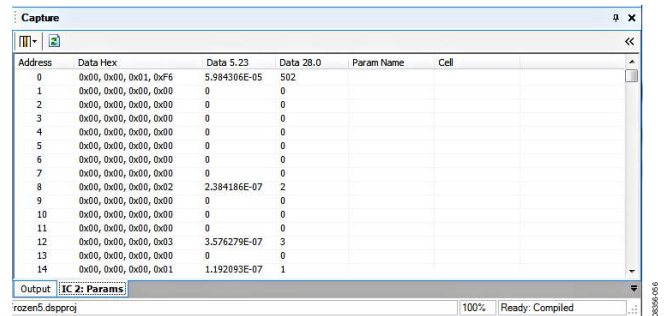

Figure 55. Parameter Visualization Window

## SEQUENCE WINDOW

Click << at the top right of the **Capture** window to open the **Display Sequence Window** (see Figure 56). In this window, sequences of data writes can be created by dragging rows from the **Capture** window or by manually entering target addresses and data values.

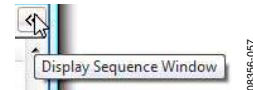

Figure 56. Display Sequence Window Button

Click the **Download Mode to Hardware** button to then initiate the sequence (see Figure 57).

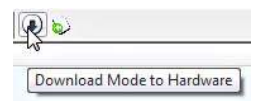

Figure 57. Download Mode to Hardware Button

Figure 58 shows an example sequence that changes the playback volume control (slewvol cell) gain value to -52 dB.

Mode	Address	Bytes	Data	Cell Name	Parameter Name
Write	440	4	0x00, 0x00, 0x52, 0x4F	slewvol	GainS200AlgGrow1gain_target

Figure 58. Example Sequence Changing the Playback Volume Control

**EXPORT PARAMETER AND REGISTER SETTINGS**

Click **Export System Files** in the toolbar to export the system files, such as parameter and register values (see Figure 59).

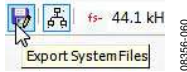

Figure 59. Export System Files Button

**SIGMASTUDIO HELP FILE**

SigmaStudio includes a **Help** file that further describes many of the algorithms and design functions described in this user guide. Access the **Help** file through the toolbar or by highlighting a block in the **Schematic** window and pressing **F1**, which brings you to the **Help** page for that block.

## FULL PARAMETER MAP

Table 12. Full Parameter Map with Default Values for  $f_s = 48$  kHz

Address	Cell Name	Parameter Name	Default Value	Function	Bytes	Sample Rate Dependent?
0x0009	audioMode	DCInpAlg1	0x00, 0x00, 0x00, 0x00	Set record/playback mode	4	No
0x000A	REC_Coeff	DCInpAlg3	0x00, 0x00, 0x00, 0x00	Set Record Mode A or Record Mode B	4	No
0x000B	GPIO	DCInpAlg4	0x00, 0x00, 0x00, 0x00	Set GPIO output flag	4	No
0x0011	WNAIlg	WindNoiseAlg2F11	0x00, 0xE8, 0x5D, 0x19	Frequency and effect gain parameters	4	Yes
0x0012	WNAIlg	WindNoiseAlg2F12	0xFF, 0x95, 0xA1, 0x9C	Frequency and effect gain parameters	4	Yes
0x0013	WNAIlg	WindNoiseAlg2F20	0x00, 0x00, 0x80, 0x53	Frequency and effect gain parameters	4	Yes
0x0014	WNAIlg	WindNoiseAlg2F21	0x00, 0x01, 0x00, 0xA6	Frequency and effect gain parameters	4	Yes
0x0015	WNAIlg	WindNoiseAlg2F30	0x00, 0xE8, 0xD0, 0x3A	Frequency and effect gain parameters	4	Yes
0x0016	WNAIlg	WindNoiseAlg2F31	0xFE, 0x2E, 0x5F, 0x8D	Frequency and effect gain parameters	4	Yes
0x0017	WNAIlg	WindNoiseAlg2F42	0x00, 0x80, 0x00, 0x00	Frequency and effect gain parameters	4	Yes
0x0018	WNAIlg	WindNoiseAlg2tc1	0x00, 0x00, 0x20, 0x00	Time constant 1 (ms)	4	Yes
0x0019	WNAIlg	WindNoiseAlg2tc11	0x00, 0x7F, 0xE0, 0x00	Time constant 1 (ms)	4	Yes
0x001A	WNAIlg	WindNoiseAlg2tc2	0x00, 0x00, 0x20, 0x00	Time constant 2 (ms)	4	Yes
0x001B	WNAIlg	WindNoiseAlg2tc22	0x00, 0x7F, 0xE0, 0x00	Time constant 2 (ms)	4	Yes
0x001C	WNAIlg	WindNoiseAlg2Level1	0x00, 0x59, 0x99, 0x9A	Level 1	4	No
0x001D	WNAIlg	WindNoiseAlg2Level2	0x00, 0x08, 0x00, 0x00	Level 2	4	No
0x001E	WNAIlg	WindNoiseAlg2attack	0x00, 0x00, 0x80, 0x00	Attack (ms)	4	Yes
0x001F	WNAIlg	WindNoiseAlg2release	0x00, 0x00, 0x00, 0x40	Release (ms)	4	Yes
0x0020	WN	stereomux1940ns40	0x00, 0x00, 0x00, 0x00	On/off (burst write Address 0x0020 and Address 0x0021 together)	4	No
0x0021	WN	stereomux1940ns41	0x00, 0x80, 0x00, 0x00	On/off (burst write Address 0x0020 and Address 0x0021 together)	4	No
0x0023	Locked Cell	param1	0x00, 0xCA, 0x9A, 0x58	Locked parameter (generated by SigmaStudio)	4	Yes
0x0024	Locked Cell	param2	0x0F, 0x35, 0x65, 0xA8	Locked parameter (generated by SigmaStudio)	4	Yes
0x0025	Locked Cell	param3	0x00, 0x7F, 0xAA, 0xE7	Locked parameter (generated by SigmaStudio)	4	Yes
0x0026	Locked Cell	param4	0x00, 0x08, 0x38, 0x65	Locked parameter (generated by SigmaStudio)	4	Yes
0x0027	Locked Cell	param5	0x00, 0x00, 0x00, 0x00	Locked parameter (generated by SigmaStudio)	4	Yes

Address	Cell Name	Parameter Name	Default Value	Function	Bytes	Sample Rate Dependent?
0x0028	Locked Cell	param6	0x00, 0x7B, 0x1A, 0x7E	Locked parameter (generated by SigmaStudio)	4	Yes
0x0029	MicDistance	Gain1940AlgNS1	0x00, 0x80, 0x00, 0x00	Gain setting related to the distance between microphones that enhances the perceived effect	4	No
0x002B	SS	stereomux1940ns30	0x00, 0x00, 0x00, 0x00	On/off (burst write Address 0x002B and Address 0x002C together)	4	No
0x002C	SS	stereomux1940ns31	0x00, 0x80, 0x00, 0x00	On/off (burst write Address 0x002B and Address 0x002C together)	4	No
0x002D 0x002E 0x002F 0x0030 0x0031	EQFilter	IndexSelMultBandAlg100b2	0x00, 0x7F, 0xAA, 0x50, 0xFF, 0x00, 0xAB, 0x60, 0x00, 0x7F, 0xAA, 0x50, 0xFF, 0x80, 0xAB, 0x20, 0x00, 0xFF, 0x54, 0x5F	Biquad F0, 0	20	Yes
0x0032 0x0033 0x0034 0x0035 0x0036	EQFilter	IndexSelMultBandAlg101b2	0x00, 0x7D, 0xBD, 0xAF, 0xFF, 0x02, 0x0A, 0x2E, 0x00, 0x80, 0x42, 0x4A, 0xFF, 0x82, 0x00, 0x07, 0x00, 0xFD, 0xF5, 0xD2	Biquad F0, 1	20	Yes
0x0037 0x0038 0x0039 0x003A 0x003B	EQFilter	IndexSelMultBandAlg102b2	0x00, 0x00, 0x00, 0x00, 0x00, 0x00, 0x00, 0x00, 0x00, 0x80, 0x00, 0x00, 0x00, 0x00, 0x00, 0x00, 0x00, 0x00, 0x00, 0x00	Biquad F0, 2	20	Yes
0x003C 0x003D 0x003E 0x003F 0x0040	EQFilter	IndexSelMultBandAlg103b2	0x00, 0x00, 0x00, 0x00, 0x00, 0x00, 0x00, 0x00, 0x00, 0x80, 0x00, 0x00, 0x00, 0x00, 0x00, 0x00, 0x00, 0x00, 0x00, 0x00	Biquad F0, 3	20	Yes
0x0041 0x0042 0x0043 0x0044 0x0045	EQFilter	IndexSelMultBandAlg104b2	0x00, 0x71, 0xCB, 0x91, 0xFF, 0x2E, 0xCC, 0xE6, 0x00, 0x81, 0xA0, 0xD2, 0xFF, 0x8C, 0x93, 0x9D, 0x00, 0xD1, 0x33, 0x1A	Biquad F0, 4	20	Yes
0x0046 0x0047 0x0048 0x0049 0x004A	EQFilter	IndexSelMultBandAlg105b2	0x00, 0x00, 0x00, 0x00, 0x00, 0x00, 0x00, 0x00, 0x00, 0x80, 0x00, 0x00, 0x00, 0x00, 0x00, 0x00, 0x00, 0x00, 0x00, 0x00	Biquad F0, 5	20	Yes
0x004B 0x004C 0x004D 0x004E 0x004F	EQFilter	IndexSelMultBandAlg110b2	0x00, 0x7E, 0xFB, 0x24, 0xFF, 0x02, 0x09, 0xB7, 0x00, 0x7E, 0xFB, 0x24, 0xFF, 0x82, 0x06, 0xEE, 0x00, 0xFD, 0xF3, 0x80	Biquad F1, 0	20	Yes

Address	Cell Name	Parameter Name	Default Value	Function	Bytes	Sample Rate Dependent?
0x0050 0x0051 0x0052 0x0053 0x0054	EQFilter	IndexSelMultBandAlg111b2	0x00, 0x7D, 0xEB, 0x86, 0xFF, 0x02, 0x83, 0x95, 0x00, 0x7F, 0xC2, 0xF7, 0xFF, 0x82, 0x51, 0x83, 0x00, 0xFD, 0x7C, 0x6B	Biquad F1, 1	20	Yes
0x0055 0x0056 0x0057 0x0058 0x0059	EQFilter	IndexSelMultBandAlg112b2	0x00, 0x00, 0x00, 0x00, 0x00, 0x00, 0x00, 0x00, 0x00, 0x80, 0x00, 0x00, 0x00, 0x00, 0x00, 0x00, 0x00, 0x00, 0x00, 0x00	Biquad F1, 2	20	Yes
0x005A 0x005B 0x005C 0x005D 0x005E	EQFilter	IndexSelMultBandAlg113b2	0x00, 0x00, 0x00, 0x00, 0x00, 0x00, 0x00, 0x00, 0x00, 0x80, 0x00, 0x00, 0x00, 0x00, 0x00, 0x00, 0x00, 0x00, 0x00, 0x00	Biquad F1, 3	20	Yes
0x005F 0x0060 0x0061 0x0062 0x0063	EQFilter	IndexSelMultBandAlg114b2	0x00, 0x00, 0x00, 0x00, 0x00, 0x00, 0x00, 0x00, 0x00, 0x80, 0x00, 0x00, 0x00, 0x00, 0x00, 0x00, 0x00, 0x00, 0x00, 0x00	Biquad F1, 4	20	Yes
0x0064 0x0065 0x0066 0x0067 0x0068	EQFilter	IndexSelMultBandAlg115b2	0x00, 0x4A, 0x91, 0x00, 0x00, 0x95, 0x22, 0x00, 0x00, 0x4A, 0x91, 0x00, 0xFF, 0xD1, 0x47, 0xB1, 0xFF, 0x84, 0x74, 0x4F	Biquad F1, 5	20	Yes
0x0069 0x006A 0x006B 0x006C 0x006D	EQFilter	IndexSelMultBandAlg120b2	0x00, 0x00, 0x00, 0x00, 0x00, 0x00, 0x00, 0x00, 0x00, 0x80, 0x00, 0x00, 0x00, 0x00, 0x00, 0x00, 0x00, 0x00, 0x00, 0x00	Biquad F2, 0	20	Yes
0x006E 0x006F 0x0070 0x0071 0x0072	EQFilter	IndexSelMultBandAlg121b2	0x00, 0x00, 0x00, 0x00, 0x00, 0x00, 0x00, 0x00, 0x00, 0x80, 0x00, 0x00, 0x00, 0x00, 0x00, 0x00, 0x00, 0x00, 0x00, 0x00	Biquad F2, 1	20	Yes
0x0073 0x0074 0x0075 0x0076 0x0077	EQFilter	IndexSelMultBandAlg122b2	0x00, 0x00, 0x00, 0x00, 0x00, 0x00, 0x00, 0x00, 0x00, 0x80, 0x00, 0x00, 0x00, 0x00, 0x00, 0x00, 0x00, 0x00, 0x00, 0x00	Biquad F2, 2	20	Yes
0x0078 0x0079 0x007A 0x007B 0x007C	EQFilter	IndexSelMultBandAlg123b2	0x00, 0x00, 0x00, 0x00, 0x00, 0x00, 0x00, 0x00, 0x00, 0x80, 0x00, 0x00, 0x00, 0x00, 0x00, 0x00, 0x00, 0x00, 0x00, 0x00	Biquad F2, 3	20	Yes
0x007D 0x007E 0x007F 0x0080 0x0081	EQFilter	IndexSelMultBandAlg124b2	0x00, 0x00, 0x00, 0x00, 0x00, 0x00, 0x00, 0x00, 0x00, 0x80, 0x00, 0x00, 0x00, 0x00, 0x00, 0x00, 0x00, 0x00, 0x00, 0x00	Biquad F2, 4	20	Yes
0x0082 0x0083 0x0084 0x0085 0x0086	EQFilter	IndexSelMultBandAlg125b2	0x00, 0x00, 0x00, 0x00, 0x00, 0x00, 0x00, 0x00, 0x00, 0x80, 0x00, 0x00, 0x00, 0x00, 0x00, 0x00, 0x00, 0x00, 0x00, 0x00	Biquad F2, 5	20	Yes

Address	Cell Name	Parameter Name	Default Value	Function	Bytes	Sample Rate Dependent?
0x008E	filtS	stereomux1940ns10	0x00, 0x00, 0x00, 0x00	On/off (burst write Address 0x008E and Address 0x008F together)	4	No
0x008F	filtS	stereomux1940ns11	0x00, 0x80, 0x00, 0x00	On/off (burst write Address 0x008E and Address 0x008F together)	4	No
0x0090	ShiftLR	Gain1940AlgNS4	0x00, 0x80, 0x00, 0x00	Shift curve left/right; Address 0x0090 and Address 0x0091 must contain the same value	4	No
0x0091	ShiftLR	Gain1940AlgNS5	0x00, 0x80, 0x00, 0x00	Shift curve left/right; Address 0x0090 and Address 0x0091 must contain the same value	4	No
0x0092	Det_Range	Gain1940AlgNS3	0x00, 0x20, 0x26, 0xF3	On/off (burst write Address 0x0092 and Address 0x0093 together)	4	No
0x0093	Det_Range	Gain1940AlgNS2	0x00, 0x20, 0x26, 0xF3	On/off (burst write Address 0x0092 and Address 0x0093 together)	4	No
0x0094	CrossLo	EQwSubDualDP42B1	0x00, 0x00, 0x10, 0xA7	Crossover LPF filter coefficient	4	Yes
0x0095	CrossLo	EQwSubDualDP41B1	0x00, 0x00, 0x21, 0x4E	Crossover LPF filter coefficient	4	Yes
0x0096	CrossLo	EQwSubDualDP40B1	0x00, 0x00, 0x10, 0xA7	Crossover LPF filter coefficient	4	Yes
0x0097	CrossLo	EQwSubDualDP42A1	0x0F, 0x88, 0x07, 0xC9	Crossover LPF filter coefficient	4	Yes
0x0098	CrossLo	EQwSubDualDP41A1	0x00, 0xF7, 0xB5, 0x9A	Crossover LPF filter coefficient	4	Yes
0x0099	CrossLo	EQwSubDualDP42B2	0x00, 0x00, 0x10, 0xA7	Crossover LPF filter coefficient	4	Yes
0x009A	CrossLo	EQwSubDualDP41B2	0x00, 0x00, 0x21, 0x4E	Crossover LPF filter coefficient	4	Yes
0x009B	CrossLo	EQwSubDualDP40B2	0x00, 0x00, 0x10, 0xA7	Crossover LPF filter coefficient	4	Yes
0x009C	CrossLo	EQwSubDualDP42A2	0x0F, 0x88, 0x07, 0xC9	Crossover LPF filter coefficient	4	Yes
0x009D	CrossLo	EQwSubDualDP41A2	0x00, 0xF7, 0xB5, 0x9A	Crossover LPF filter coefficient	4	Yes
0x00A2	CrossHi	EQwSubDualDP32B1	0x00, 0x7B, 0xEB, 0x74	Crossover HPF filter coefficient	4	Yes
0x00A3	CrossHi	EQwSubDualDP31B1	0x0F, 0x08, 0x29, 0x18	Crossover HPF filter coefficient	4	Yes
0x00A4	CrossHi	EQwSubDualDP30B1	0x00, 0x7B, 0xEB, 0x74	Crossover HPF filter coefficient	4	Yes
0x00A5	CrossHi	EQwSubDualDP32A1	0x0F, 0x88, 0x07, 0xC9	Crossover HPF filter coefficient	4	Yes
0x00A6	CrossHi	EQwSubDualDP31A1	0x00, 0xF7, 0xB5, 0x9A	Crossover HPF filter coefficient	4	Yes
0x00A7	CrossHi	EQwSubDualDP32B2	0x00, 0x7B, 0xEB, 0x74	Crossover HPF filter coefficient	4	Yes



Address	Cell Name	Parameter Name	Default Value	Function	Bytes	Sample Rate Dependent?
0x00A8	CrossHi	EQwSubDualDP31B2	0x0F, 0x08, 0x29, 0x18	Crossover HPF filter coefficient	4	Yes
0x00A9	CrossHi	EQwSubDualDP30B2	0x00, 0x7B, 0xEB, 0x74	Crossover HPF filter coefficient	4	Yes
0x00AA	CrossHi	EQwSubDualDP32A2	0x0F, 0x88, 0x07, 0xC9	Crossover HPF filter coefficient	4	Yes
0x00AB	CrossHi	EQwSubDualDP31A2	0x00, 0xF7, 0xB5, 0x9A	Crossover HPF filter coefficient	4	Yes
0x00B0	LoDet_Filter	EQwSubDualDP62B1	0x00, 0x00, 0x24, 0xE2	Crossover LPF detection path filter coefficient	4	Yes
0x00B1	LoDet_Filter	EQwSubDualDP61B1	0x00, 0x00, 0x49, 0xC4	Crossover LPF detection path filter coefficient	4	Yes
0x00B2	LoDet_Filter	EQwSubDualDP60B1	0x00, 0x00, 0x24, 0xE2	Crossover LPF detection path filter coefficient	4	Yes
0x00B3	LoDet_Filter	EQwSubDualDP62A1	0x0F, 0x8B, 0xDA, 0xCC	Crossover LPF detection path filter coefficient	4	Yes
0x00B4	LoDet_Filter	EQwSubDualDP61A1	0x00, 0xF3, 0x91, 0xAC	Crossover LPF detection path filter coefficient	4	Yes
0x00B5	LoDet_Filter	EQwSubDualDP62B2	0x00, 0x00, 0x24, 0xE2	Crossover LPF detection path filter coefficient	4	Yes
0x00B6	LoDet_Filter	EQwSubDualDP61B2	0x00, 0x00, 0x49, 0xC4	Crossover LPF detection path filter coefficient	4	Yes
0x00B7	LoDet_Filter	EQwSubDualDP60B2	0x00, 0x00, 0x24, 0xE2	Crossover LPF detection path filter coefficient	4	Yes
0x00B8	LoDet_Filter	EQwSubDualDP62A2	0x0F, 0x8B, 0xDA, 0xCC	Crossover LPF detection path filter coefficient	4	Yes
0x00B9	LoDet_Filter	EQwSubDualDP61A2	0x00, 0xF3, 0x91, 0xAC	Crossover LPF detection path filter coefficient	4	Yes
0x00BE	HiDet_Filter	EQwSubDualDP52B1	0x00, 0x7D, 0x44, 0xE0	Crossover HPF detection path filter coefficient	4	Yes
0x00BF	HiDet_Filter	EQwSubDualDP51B1	0x0F, 0x05, 0x76, 0x40	Crossover HPF detection path filter coefficient	4	Yes
0x00C0	HiDet_Filter	EQwSubDualDP50B1	0x00, 0x7D, 0x44, 0xE0	Crossover HPF detection path filter coefficient	4	Yes
0x00C1	HiDet_Filter	EQwSubDualDP52A1	0x0F, 0x85, 0x67, 0x55	Crossover HPF detection path filter coefficient	4	Yes
0x00C2	HiDet_Filter	EQwSubDualDP51A1	0x00, 0xFA, 0x7A, 0xD5	Crossover HPF detection path filter coefficient	4	Yes
0x00C3	HiDet_Filter	EQwSubDualDP52B2	0x00, 0x7D, 0x44, 0xE0	Crossover HPF detection path filter coefficient	4	Yes

Address	Cell Name	Parameter Name	Default Value	Function	Bytes	Sample Rate Dependent?
0x00C4	HiDet_Filter	EQwSubDualDP51B2	0x0F, 0x05, 0x76, 0x40	Crossover HPF detection path filter coefficient	4	Yes
0x00C5	HiDet_Filter	EQwSubDualDP50B2	0x00, 0x7D, 0x44, 0xE0	Crossover HPF detection path filter coefficient	4	Yes
0x00C6	HiDet_Filter	EQwSubDualDP52A2	0x0F, 0x85, 0x67, 0x55	Crossover HPF detection path filter coefficient	4	Yes
0x00C7	HiDet_Filter	EQwSubDualDP51A2	0x00, 0xFA, 0x7A, 0xD5	Crossover HPF detection path filter coefficient	4	Yes
0x00CC	HighPass_Comp	PeakDBCompLUTAlgPG30decay	0x00, 0x00, 0x00, 0x04	REC_Auto: decay	4	Yes
0x00CD	HighPass_Comp	PeakDBCompLUTAlgPG30hold	0x00, 0x00, 0x00, 0x60	REC_Auto: hold	4	Yes
0x00CE 0x00CF 0x00D0 0x00D1 0x00D2 0x00D3 0x00D4 0x00D5 0x00D6 0x00D7 0x00D8 0x00D9 0x00DA 0x00DB 0x00DC 0x00DD 0x00DE 0x00DF 0x00E0 0x00E1 0x00E2 0x00E3 0x00E4 0x00E5 0x00E6 0x00E7 0x00E8 0x00E9 0x00EA 0x00EB 0x00EC 0x00ED 0x00EE	HighPass_Comp	PeakDBCompLUTAlgPG30tab	0x00, 0x05, 0x1A, 0x96, 0x00, 0x04, 0xB6, 0x9B, 0x00, 0x04, 0xAD, 0x54, 0x00, 0x05, 0x55, 0x55, 0x00, 0x08, 0x55, 0xC1, 0x00, 0x11, 0x6C, 0xA5, 0x00, 0x25, 0x0E, 0xD2, 0x00, 0x4D, 0x9C, 0x93, 0x00, 0xA0, 0x10, 0xF5, 0x01, 0x46, 0xB2, 0x33, 0x02, 0x80, 0x9F, 0x0A, 0x03, 0xF0, 0xCE, 0x62, 0x05, 0x54, 0x59, 0xF2, 0x05, 0xEF, 0xF5, 0xFC, 0x05, 0xBA, 0x65, 0x98, 0x05, 0x17, 0xAD, 0xEF, 0x04, 0x3A, 0x77, 0xC5, 0x03, 0x56, 0xDC, 0x88, 0x02, 0x8B, 0x2A, 0xC5, 0x01, 0xE7, 0x60, 0xA5, 0x01, 0x67, 0x06, 0x39, 0x01, 0x05, 0xD8, 0x28, 0x00, 0xBE, 0x7E, 0xE5, 0x00, 0x8A, 0x46, 0xF6, 0x00, 0x64, 0x17, 0x5B, 0x00, 0x48, 0x3E, 0xCA, 0x00, 0x34, 0x06, 0x48, 0x00, 0x25, 0x6A, 0x11, 0x00, 0x1A, 0xE6, 0xE6, 0x00, 0x13, 0x05, 0xC6, 0x00, 0x0D, 0x73, 0x73, 0x00, 0x09, 0x82, 0xE3, 0x00, 0x06, 0xB9, 0xBA	REC_Auto: compressor curve points	132	No
0x00EF	HighPass_Comp	PeakDBCompLUTAlgPG31decay	0x00, 0x00, 0x00, 0x12	REC_Manual: decay	4	Yes
0x00F0	HighPass_Comp	PeakDBCompLUTAlgPG31hold	0x00, 0x00, 0x01, 0xE0	REC_Manual: hold	4	Yes

Address	Cell Name	Parameter Name	Default Value	Function	Bytes	Sample Rate Dependent?
0x00F1	HighPass_Comp	PeakDBCompLUTAlgPG31tab	0x00, 0x1D, 0xC7, 0xFA,	REC_Manual: compressor curve points	132	No
0x00F2			0x00, 0x1F, 0xA6, 0x78,			
0x00F3			0x00, 0x24, 0xCD, 0xBF,			
0x00F4			0x00, 0x2D, 0xB0, 0xDE,			
0x00F5			0x00, 0x3A, 0x4E, 0x7F,			
0x00F6			0x00, 0x47, 0xE3, 0x23,			
0x00F7			0x00, 0x67, 0x41, 0xE8,			
0x00F8			0x00, 0xA1, 0x64, 0x8B,			
0x00F9			0x00, 0xF3, 0x71, 0x72,			
0x00FA			0x01, 0x4B, 0x5C, 0x80,			
0x00FB			0x01, 0x96, 0x84, 0x19,			
0x00FC			0x01, 0xF9, 0x0D, 0x62,			
0x00FD			0x02, 0x8A, 0xA7, 0xCA,			
0x00FE			0x03, 0x24, 0x67, 0xA2,			
0x00FF			0x03, 0x9A, 0x7A, 0x83,			
0x0100			0x03, 0xD1, 0x34, 0x62,			
0x0101			0x03, 0xA2, 0xBD, 0x15,			
0x0102			0x03, 0x3D, 0x07, 0x65,			
0x0103			0x02, 0xC9, 0xE3, 0xC3,			
0x0104			0x02, 0x4D, 0x52, 0x70,			
0x0105			0x01, 0xCE, 0xBA, 0xD0,			
0x0106	0x01, 0x5C, 0x48, 0xE1,					
0x0107	0x00, 0xFF, 0x34, 0xC9,					
0x0108	0x00, 0xB8, 0x8A, 0x49,					
0x0109	0x00, 0x83, 0xA5, 0x3C,					
0x010A	0x00, 0x5D, 0x40, 0x76,					
0x010B	0x00, 0x42, 0x04, 0x69,					
0x010C	0x00, 0x2E, 0xBC, 0x93,					
0x010D	0x00, 0x21, 0x16, 0x45,					
0x010E	0x00, 0x17, 0x65, 0x63,					
0x010F	0x00, 0x10, 0x8B, 0x23,					
0x0110	0x00, 0x0B, 0xB2, 0xB1,					
0x0111	0x00, 0x08, 0x45, 0x91					
0x0112	HighPass_Comp	PeakDBCompLUTAlgPG32decay	0x00, 0x00, 0x00, 0xB6	Speaker: decay	4	Yes
0x0113	HighPass_Comp	PeakDBCompLUTAlgPG32hold	0x00, 0x00, 0x00, 0xF0	Speaker: hold	4	Yes

Address	Cell Name	Parameter Name	Default Value	Function	Bytes	Sample Rate Dependent?
0x0114	HighPass_Comp	PeakDBCompLUTAlgPG32tab	0x00, 0x80, 0x00, 0x00,	Speaker: compressor curve points	132	No
0x0115			0x00, 0x80, 0x00, 0x00,			
0x0116			0x00, 0x80, 0x00, 0x00,			
0x0117			0x00, 0x80, 0x00, 0x00,			
0x0118			0x00, 0x80, 0x00, 0x00,			
0x0119			0x00, 0x80, 0x00, 0x00,			
0x011A			0x00, 0x80, 0x00, 0x00,			
0x011B			0x00, 0x80, 0x00, 0x00,			
0x011C			0x00, 0x80, 0x00, 0x00,			
0x011D			0x00, 0x80, 0x00, 0x00,			
0x011E			0x00, 0x80, 0x00, 0x00,			
0x011F			0x00, 0x80, 0x00, 0x00,			
0x0120			0x00, 0x80, 0x00, 0x00,			
0x0121			0x00, 0x80, 0x00, 0x00,			
0x0122			0x00, 0x80, 0x00, 0x00,			
0x0123			0x00, 0x80, 0x00, 0x00,			
0x0124			0x00, 0x80, 0x00, 0x00,			
0x0125			0x00, 0x80, 0x00, 0x00,			
0x0126			0x00, 0x80, 0x00, 0x00,			
0x0127			0x00, 0x80, 0x00, 0x00,			
0x0128			0x00, 0x80, 0x00, 0x00,			
0x0129			0x00, 0x80, 0x00, 0x00,			
0x012A			0x00, 0x7F, 0xF0, 0x61,			
0x012B			0x00, 0x7D, 0x6C, 0x21,			
0x012C			0x00, 0x75, 0x7A, 0x64,			
0x012D			0x00, 0x68, 0xDB, 0x84,			
0x012E			0x00, 0x5A, 0x4C, 0x32,			
0x012F			0x00, 0x4C, 0x3E, 0xA8,			
0x0130	0x00, 0x40, 0x26, 0xE7,					
0x0131	0x00, 0x2D, 0x5C, 0xBF,					
0x0132	0x00, 0x20, 0x13, 0x74,					
0x0133	0x00, 0x16, 0xAE, 0x60,					
0x0134	0x00, 0x10, 0x09, 0xBA					
0x0138	HighPass_Comp	PeakDBCompLUTAlgPG30post_gain	0x00, 0x80, 0x00, 0x00	REC_Auto: post gain	4	No
0x0139	HighPass_Comp	PeakDBCompLUTAlgPG31post_gain	0x00, 0x80, 0x00, 0x00	REC_Manual: post gain	4	No
0x013A	HighPass_Comp	PeakDBCompLUTAlgPG32post_gain	0x00, 0x80, 0x00, 0x00	Speaker: post gain	4	No
0x0140	LowPass_Comp	PeakDBCompLUTAlgPG40decay	0x00, 0x00, 0x00, 0x04	REC_Auto: decay	4	Yes
0x0141	LowPass_Comp	PeakDBCompLUTAlgPG40hold	0x00, 0x00, 0x00, 0x60	REC_Auto: hold	4	Yes

Address	Cell Name	Parameter Name	Default Value	Function	Bytes	Sample Rate Dependent?
0x0142	LowPass_Comp	PeakDBCompLUTAlgPG40tab	0x00, 0x05, 0x1A, 0x96,	REC_Auto: compressor curve points	132	No
0x0143			0x00, 0x04, 0xB6, 0x9B,			
0x0144			0x00, 0x04, 0xAD, 0x54,			
0x0145			0x00, 0x05, 0x55, 0x55,			
0x0146			0x00, 0x08, 0x55, 0xC1,			
0x0147			0x00, 0x11, 0x6C, 0xA5,			
0x0148			0x00, 0x25, 0x0E, 0xD2,			
0x0149			0x00, 0x4D, 0x9C, 0x93,			
0x014A			0x00, 0xA0, 0x10, 0xF5,			
0x014B			0x01, 0x46, 0xB2, 0x33,			
0x014C			0x02, 0x80, 0x9F, 0x0A,			
0x014D			0x03, 0xF0, 0xCE, 0x62,			
0x014E			0x05, 0x54, 0x59, 0xF2,			
0x014F			0x05, 0xEF, 0xF5, 0xFC,			
0x0150			0x05, 0xBA, 0x65, 0x98,			
0x0151			0x05, 0x17, 0xAD, 0xEF,			
0x0152			0x04, 0x3A, 0x77, 0xC5,			
0x0153			0x03, 0x56, 0xDC, 0x88,			
0x0154			0x02, 0x8B, 0x2A, 0xC5,			
0x0155			0x01, 0xE7, 0x60, 0xA5,			
0x0156			0x01, 0x67, 0x06, 0x39,			
0x0157			0x01, 0x05, 0xD8, 0x28,			
0x0158			0x00, 0xBE, 0x7E, 0xE5,			
0x0159			0x00, 0x8A, 0x46, 0xF6,			
0x015A			0x00, 0x64, 0x17, 0x5B,			
0x015B			0x00, 0x48, 0x3E, 0xCA,			
0x015C			0x00, 0x34, 0x06, 0x48,			
0x015D	0x00, 0x25, 0x6A, 0x11,					
0x015E	0x00, 0x1A, 0xE6, 0xE6,					
0x015F	0x00, 0x13, 0x05, 0xC6,					
0x0160	0x00, 0x0D, 0x73, 0x73,					
0x0161	0x00, 0x09, 0x82, 0xE3,					
0x0162	0x00, 0x06, 0xB9, 0xBA					
0x0163	LowPass_Comp	PeakDBCompLUTAlgPG41decay	0x00, 0x00, 0x00, 0x12	REC_Manual: decay	4	Yes
0x0164	LowPass_Comp	PeakDBCompLUTAlgPG41hold	0x00, 0x00, 0x01, 0xE0	REC_Manual: hold	4	Yes

Address	Cell Name	Parameter Name	Default Value	Function	Bytes	Sample Rate Dependent?
0x0165 0x0166 0x0167 0x0168 0x0169 0x016A 0x016B 0x016C 0x016D 0x016E 0x016F 0x0170 0x0171 0x0172 0x0173 0x0174 0x0175 0x0176 0x0177 0x0178 0x0179 0x017A 0x017B 0x017C 0x017D 0x017E 0x017F 0x0180 0x0181 0x0182 0x0183 0x0184 0x0185	LowPass_Comp	PeakDBCompLUTAlgPG41tab	0x00, 0x1D, 0xC7, 0xFA, 0x00, 0x1F, 0xA6, 0x78, 0x00, 0x24, 0xCD, 0xBF, 0x00, 0x2D, 0xB0, 0xDE, 0x00, 0x3A, 0x4E, 0x7F, 0x00, 0x47, 0xE3, 0x23, 0x00, 0x67, 0x41, 0xE8, 0x00, 0xA1, 0x64, 0x8B, 0x00, 0xF3, 0x71, 0x72, 0x01, 0x4B, 0x5C, 0x80, 0x01, 0x96, 0x84, 0x19, 0x01, 0xF9, 0x0D, 0x62, 0x02, 0x8A, 0xA7, 0xCA, 0x03, 0x24, 0x67, 0xA2, 0x03, 0x9A, 0x7A, 0x83, 0x03, 0xD1, 0x34, 0x62, 0x03, 0xA2, 0xBD, 0x15, 0x03, 0x3D, 0x07, 0x65, 0x02, 0xC9, 0xE3, 0xC3, 0x02, 0x4D, 0x52, 0x70, 0x01, 0xCE, 0xBA, 0xD0, 0x01, 0x5C, 0x48, 0xE1, 0x00, 0xFF, 0x34, 0xC9, 0x00, 0xB8, 0x8A, 0x49, 0x00, 0x83, 0xA5, 0x3C, 0x00, 0x5D, 0x40, 0x76, 0x00, 0x42, 0x04, 0x69, 0x00, 0x2E, 0xBC, 0x93, 0x00, 0x21, 0x16, 0x45, 0x00, 0x17, 0x65, 0x63, 0x00, 0x10, 0x8B, 0x23, 0x00, 0x0B, 0xB2, 0xB1, 0x00, 0x08, 0x45, 0x91	REC_Manual: compressor curve points	132	No
0x0186	LowPass_Comp	PeakDBCompLUTAlgPG42decay	0x00, 0x00, 0x00, 0xB6	Speaker: decay	4	Yes
0x0187	LowPass_Comp	PeakDBCompLUTAlgPG42hold	0x00, 0x00, 0x00, 0xF0	Speaker: hold	4	Yes

Address	Cell Name	Parameter Name	Default Value	Function	Bytes	Sample Rate Dependent?
0x0188 0x0189 0x018A 0x018B 0x018C 0x018D 0x018E 0x018F 0x0190 0x0191 0x0192 0x0193 0x0194 0x0195 0x0196 0x0197 0x0198 0x0199 0x019A 0x019B 0x019C 0x019D 0x019E 0x019F 0x01A0 0x01A1 0x01A2 0x01A3 0x01A4 0x01A5 0x01A6 0x01A7 0x01A8	LowPass_Comp	PeakDBCompLUTAlgPG42tab	0x00, 0x80, 0x00, 0x00, 0x00, 0x7F, 0xF0, 0x61, 0x00, 0x7D, 0x6C, 0x21, 0x00, 0x75, 0x7A, 0x64, 0x00, 0x68, 0xDB, 0x84, 0x00, 0x5A, 0x4C, 0x32, 0x00, 0x4C, 0x3E, 0xA8, 0x00, 0x40, 0x26, 0xE7, 0x00, 0x2D, 0x5C, 0xBF, 0x00, 0x20, 0x13, 0x74, 0x00, 0x16, 0xAE, 0x60, 0x00, 0x10, 0x09, 0xBA	Speaker: compressor curve points	132	No
0x01AC	LowPass_Comp	PeakDBCompLUTAlgPG40post_gain	0x00, 0x80, 0x00, 0x00	REC_Auto: post gain	4	No
0x01AD	LowPass_Comp	PeakDBCompLUTAlgPG41post_gain	0x00, 0x80, 0x00, 0x00	REC_Manual: post gain	4	No
0x01AE	LowPass_Comp	PeakDBCompLUTAlgPG42post_gain	0x00, 0x80, 0x00, 0x00	Speaker: post gain	4	No
0x01B4	compS	stereomux1940ns50	0x00, 0x00, 0x00, 0x00	On/off (burst write Address 0x01B4 and Address 0x01B5 together)	4	No
0x01B5	compS	stereomux1940ns51	0x00, 0x80, 0x00, 0x00	On/off (burst write Address 0x01B4 and Address 0x01B5 together)	4	No

Address	Cell Name	Parameter Name	Default Value	Function	Bytes	Sample Rate Dependent?
0x01B6	dmute	MuteSWLinSlewAlg1mute	0x00, 0x00, 0x00, 0x00	Mute digital (record) output	4	No
0x01B7	dmute	MuteSWLinSlewAlg1step	0x00, 0x00, 0x40, 0x00	Slew rate for digital mute	4	Yes
0x01B8	slewwol	GainS200AlgGrow1gain_target	0x00, 0x80, 0x00, 0x00	Analog output volume control	4	No
0x01BA	amute	MuteSWLinSlewAlg2mute	0x00, 0x00, 0x00, 0x00	Mute analog (playback) output	4	No
0x01BB	amute	MuteSWLinSlewAlg2step	0x00, 0x00, 0x40, 0x00	Slew rate for analog mute	4	Yes
0x07FA 0x07FB	slewwol	GainS200AlgGrow1alpha	0x00, 0x7F, 0xF2, 0x59, 0x00, 0x00, 0x0D, 0xA7	Slew rate for analog volume control	8	Yes

Evaluation boards are only intended for device evaluation and not for production purposes. Evaluation boards are supplied "as is" and without warranties of any kind, express, implied, or statutory including, but not limited to, any implied warranty of merchantability or fitness for a particular purpose. No license is granted by implication or otherwise under any patents or other intellectual property by application or use of evaluation boards. Information furnished by Analog Devices is believed to be accurate and reliable. However, no responsibility is assumed by Analog Devices for its use, nor for any infringements of patents or other rights of third parties that may result from its use. Analog Devices reserves the right to change devices or specifications at any time without notice. Trademarks and registered trademarks are the property of their respective owners. Evaluation boards are not authorized to be used in life support devices or systems.