



### Features

- 5V Input
- 18A Output Current
- DSP Compatible
- Low-Profile (8mm)
- >90% Efficiency
- Output Margin Control ( $\pm 5\%$ )
- Adjustable Output Voltage
- On/Off Inhibit Function
- Pre-Bias Startup Capability
- Over-Current Protection
- Over-Temperature Protection
- Small Footprint (0.736 in<sup>2</sup>, Suffix 'N')
- Surface Mount Compatible
- IPC Lead Free 2

### Description

The PT5800 Excalibur™ series of integrated switching regulators (ISRs) combines outstanding power density with a comprehensive list of features. They are an ideal choice for applications where board space is a premium and performance cannot be compromised. These modules provide 18A of output current, yet are housed in a low-profile, 18-pin package that is almost half the size of the previous product generation. The integral copper case construction requires no heatsink, and offers the advantages of solderability and a small footprint (0.736 in<sup>2</sup> for suffix 'N'). Both through-hole and surface mount pin configurations are available.

The PT5800 series operates from a 5-V input bus and provides a convenient point-of-load power source for the industry's latest high-performance DSPs and microprocessors. The series includes output voltage options as low as 1.0VDC.

Other features include external output voltage adjustment, a  $\pm 5\%$  margin control, on/off inhibit, short circuit protection, thermal shutdown, and a differential remote sense.

### Ordering Information

|         |             |
|---------|-------------|
| PT5801□ | = 3.3 Volts |
| PT5802□ | = 2.5 Volts |
| PT5803□ | = 1.8 Volts |
| PT5804□ | = 1.5 Volts |
| PT5805□ | = 1.2 Volts |
| PT5806□ | = 1.0 Volts |

### PT Series Suffix (PT1234 x)

| Case/Pin Configuration | Order Suffix | Package Code |
|------------------------|--------------|--------------|
| Vertical               | <b>N</b>     | (EPP)        |
| Horizontal             | <b>A</b>     | (EPQ)        |
| SMD                    | <b>C</b>     | (EPS)        |

(Reference the applicable package code drawing for the dimensions and PC board layout)

### Pin-Out Information

| Pin | Function              |
|-----|-----------------------|
| 1   | V <sub>o</sub> Adjust |
| 2   | Inhibit*              |
| 3   | Margin Dn*            |
| 4   | Margin Up*            |
| 5   | V <sub>in</sub>       |
| 6   | V <sub>in</sub>       |
| 7   | V <sub>in</sub>       |
| 8   | Sense(-)              |
| 9   | GND                   |
| 10  | GND                   |
| 11  | GND                   |
| 12  | GND                   |
| 13  | GND                   |
| 14  | V <sub>out</sub>      |
| 15  | V <sub>out</sub>      |
| 16  | V <sub>out</sub>      |
| 17  | V <sub>out</sub>      |
| 18  | Sense(+)              |

\* Denotes negative logic:  
Open = Normal operation  
Ground = Function active

### Standard Application

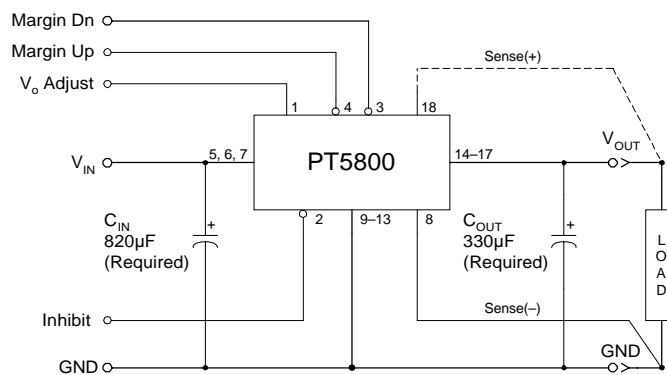

C<sub>in</sub> = Required 820µF  
C<sub>out</sub> = Required 330µF

### Specifications (Unless otherwise stated, $T_a = 25^\circ\text{C}$ , $V_{in} = 5\text{V}$ , $C_{in} = 820\mu\text{F}$ , $C_{out} = 330\mu\text{F}$ , and $I_o = I_{o,max}$ )

| Characteristics             | Symbols                   | Conditions  | PT5800 SERIES  |              |          | Units                 |   |
|-----------------------------|---------------------------|---|----------------|--------------|----------|-----------------------|---|
|                             |                           |   | Min            | Typ          | Max      |                       |   |
| Output Current              | $I_o$                     | $V_{in} = 5\text{V}$  | 0              | —            | 18       | A                     |   |
| Input Voltage Range         | $V_{in}$                  | Over $I_o$ range  | 4.5            | —            | 5.5      | V                     |   |
| Set-Point Voltage Tolerance | $V_o \text{ tol}$         |   | —              | —            | $\pm 2$  | $\%V_o$               |   |
| Temperature Variation       | $\Delta\text{Reg}_{temp}$ | $-40^\circ\text{C} < T_a < +85^\circ\text{C}$   | —              | $\pm 0.5$    | —        | $\%V_o$               |   |
| Line Regulation             | $\Delta\text{Reg}_{line}$ | Over $V_{in}$ range   | —              | $\pm 8$      | —        | mV                    |   |
| Load Regulation             | $\Delta\text{Reg}_{load}$ | Over $I_o$ range  | —              | $\pm 5$      | —        | mV                    |   |
| Total Output Variation      | $\Delta\text{Reg}_{tot}$  | Includes set-point, line, load,<br>$-40^\circ\text{C} \leq T_a \leq +85^\circ\text{C}$          | —              | —            | $\pm 3$  | $\%V_o$               |   |
| Efficiency                  | $\eta$                    | $I_o = 12\text{A}$  | PT5801 (3.3V)  | —            | 94       | —                     | % |
|                             |                           |   | PT5802 (2.5V)  | —            | 92       | —                     |   |
|                             |                           |   | PT5803 (1.8V)  | —            | 90       | —                     |   |
|                             |                           |   | PT5804 (1.5V)  | —            | 88       | —                     |   |
|                             |                           |   | PT5805 (1.2V)  | —            | 86       | —                     |   |
|                             |                           |   | PT5806 (1.0V)  | —            | 84       | —                     |   |
| $V_o$ Ripple (pk-pk)        | $V_r$                     | 20MHz bandwidth   | —              | 20           | —        | mVpp                  |   |
| Transient Response          | $t_{tr}$<br>$\Delta V_r$  | 1A/ $\mu\text{s}$ load step, 50 to 100% $I_{o,max}$ ,<br>Recovery Time<br>$V_o$ over/undershoot | —              | 50           | —        | $\mu\text{Sec}$<br>mV |   |
|                             |                           |   | —              | 100          | —        |                       |   |
| Over-Current Threshold      | $I_{TRIP}$                | Reset, followed by auto-recovery  | —              | 30           | —        | A                     |   |
| Output Voltage Adjust       | $V_o \text{ adj}$         | With $V_o$ Adjust<br>With Margin Up/Dn  | —              | $\pm 15$ (1) | —        | %                     |   |
| Switching Frequency         | $f_s$                     | Over $V_{in}$ and $I_o$ ranges  | 250            | 300          | 350      | kHz                   |   |
| Inhibit Control (pin 2)     | $V_{IH}$<br>$V_{IL}$      | Referenced to GND (pins 9–13)   | $V_{in} - 0.5$ | —            | Open (2) | V                     |   |
| Input High Voltage          |                           |   | $-0.2$         | —            | 0.8      |                       |   |
| Input Low Voltage           | $V_{IL}$                  |   | —              | —            | —        |                       |   |
| Input Low Current           | $I_{IL}$                  | Pin 2 to GND  | —              | -10          | —        | $\mu\text{A}$         |   |
| Standby Input Current       | $I_{in \text{ standby}}$  | Pin 2 to GND  | —              | 5            | —        | mA                    |   |
| External Input Capacitance  | $C_{in}$                  |   | 820 (3)        | —            | —        | $\mu\text{F}$         |   |
| External Output Capacitance | $C_{out}$                 |   | 330 (4)        | —            | 5,000    | $\mu\text{F}$         |   |
| Operating Temperature Range | $T_a$                     | Over $V_{in}$ range   | -40 (4)        | —            | 85 (5)   | $^\circ\text{C}$      |   |
| Over-Temperature Protection | OTP                       | Measured at center of case, auto-reset  | —              | 110          | —        | $^\circ\text{C}$      |   |
| Solder Reflow Temperature   | $T_{reflow}$              | Surface temperature of module pins or case  | —              | —            | 215 (6)  | $^\circ\text{C}$      |   |
| Storage Temperature         | $T_s$                     | —   | -40            | —            | 125      | $^\circ\text{C}$      |   |
| Reliability                 | MTBF                      | Per Bellcore TR-332<br>50% stress, $T_a = 40^\circ\text{C}$ , ground benign                     | 5.8            | —            | —        | $10^6$ Hrs            |   |
| Mechanical Shock            |                           | Mil-STD-883D, Method 2002.3<br>Half Sine, mounted to a fixture                                  | —              | 500          | —        | G                     |   |
| Mechanical Vibration        |                           | Mil-STD-883D, Method 2007.2,<br>20–2000 Hz, PCB mounted   | Suffix N       | —            | 20 (7)   | —                     | G |
|                             |                           |   | Suffixes A, C  | —            | 20 (7)   | —                     |   |
| Weight                      | —                         | —   | —              | 20           | —        | grams                 |   |
| Flammability                | —                         | Materials meet UL 94V-0   | —              | —            | —        | —                     |   |

- Notes:** (1) This is a typical value. For the adjustment limits of a specific model consult the related application note on output voltage adjustment.  
 (2) The Inhibit control (pin 2) has an internal pull-up to  $V_{in}$ , and if left open-circuit the module will operate when input power is applied. A small low-leakage (<100nA) MOSFET is recommended to control this input. See application notes for more information.  
 (3) An 820 $\mu\text{F}$  electrolytic input capacitor is required for proper operation. This capacitor must be rated for a minimum of 0.7 Arms of ripple current.  
 (4) For operation below  $0^\circ\text{C}$ ,  $C_{OUT}$  must have stable characteristics. Use either low-ESR tantalum or Oscon<sup>®</sup> type capacitors.  
 (5) See SOA curves or consult factory for the appropriate derating.  
 (6) During solder reflow of SMD package version do not elevate the module case, pins, or internal component temperatures above a peak of  $215^\circ\text{C}$ . For further guidance refer to the application note, "Reflow Soldering Requirements for Plug-in Power Surface Mount Products," (SLTA051)  
 (7) The case pins on the through-hole package types (suffixes N & A) must be soldered. For more information see the applicable package outline drawing.

### Pin Descriptions

**V<sub>in</sub>**: The positive supply voltage input for the module with respect to the common ground (*GND*).

**V<sub>out</sub>**: This is the regulated output voltage from the module with respect to the common ground (*GND*).

**GND**: The common ground node to which the input, output, and external control signals are referenced.

**Sense(-)**: Provides the regulator with the ability to sense the set-point voltage directly across the load. For optimum output voltage accuracy this pin should always be connected to *GND*, even for applications that demand a relatively light load.

**Sense(+)**: When used with *Sense(-)*, the regulation circuitry will compensate for voltage drop between the converter and the load. The pin may be left open circuit, but connecting it to *V<sub>out</sub>* will optimize load regulation.

**Inhibit\***: This is an open-collector (open-drain) negative logic input, referenced to *GND*. Pulling this pin to *GND* disables the module's output voltage. If *Inhibit\** is

left open circuit, the output will be active whenever a valid input source is applied.

**V<sub>o</sub> Adjust**: This pin is used to trim the output voltage over a typical range of  $\pm 15\%$  of nominal. The adjustment method uses an external resistor. The resistor is connected from *V<sub>o</sub> Adjust* to either the (-)*Sense* or (+)*Sense*, in order to adjust the output either up or down, respectively. Consult the related application note for the adjust limits of a specific part.

**Margin Dn\***: When this open-collector (open-drain) input is asserted to *GND*, the output voltage is automatically decreased by 5% from the nominal. This feature is used in applications where the load circuit must be tested for operation at the extreme values of its supply voltage tolerance.

**Margin Up\***: This is an open-collector (open-drain) input. When this is asserted to *GND*, the output voltage is automatically increased by 5% from the nominal.

### Typical Characteristics

**Performance Data; V<sub>in</sub> = 5V** (See Note A)

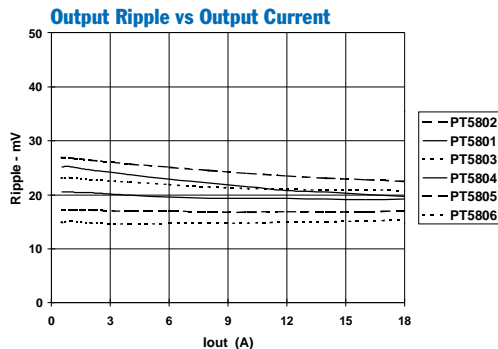
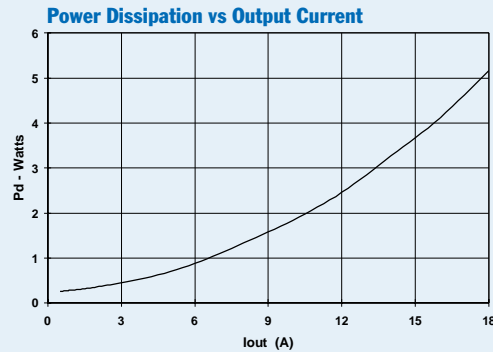
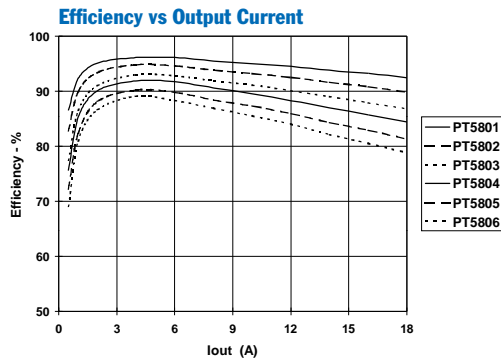

**Safe Operating Curves; V<sub>in</sub> = 5V** (See Note B)

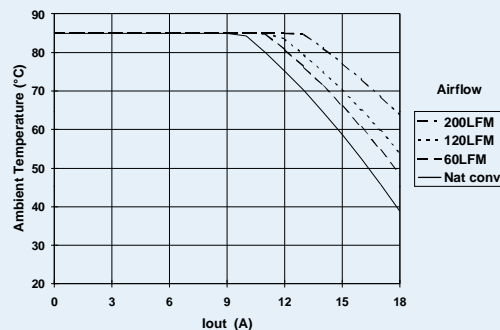

**Note A:** Characteristic data has been developed from actual products tested at 25°C. This data is considered typical data for the ISR.

**Note B:** SOA curves represent operating conditions at which internal components are at or below manufacturer's maximum rated operating temperatures.

## Operating Features and System Considerations for the PT5800 & PT5810 Regulator Series

The PT5800 (5-V input) and the PT5810 (3.3-V input) series of integrated switching regulators (ISRs) provide step-down voltage conversion for output loads of up to 18A.

### Power up & Soft-Start Timing

Following either the application of a valid input source voltage, or the removal of a ground signal to the *Inhibit\** control pin (with input power applied), the regulator will initiate a soft-start power up. The soft start slows the rate at which the output voltage rises, and also introduces a short time delay,  $t_d$  (approx. 2ms). Figure 1-1 shows the power-up characteristic of a PT5801 (3.3V) with a 10-A load.

Figure 1-1

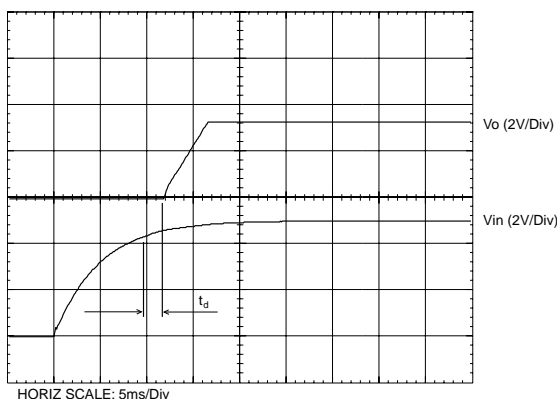

### Differential Remote Sense

Connecting the *Sense(+)* and *Sense(-)* pins to the load circuit allows the regulator to compensate for limited amounts of 'IR' voltage drop. This voltage drop is caused by current flowing through the connection resistance between the regulator and the 'point of regulation' some distance away. Leaving the sense pins disconnected will not damage the regulator or load circuitry. An internal 15 $\Omega$  resistor, connected between each sense pin and its corresponding output node, keeps the output voltage in regulation. However, it is important to connect *Sense(-)* to *GND* locally, as this provides a return path for the regulator's internal bias currents.

With the sense leads connected, the difference between the voltage measured at  $V_{out}$  and *GND* pins, and that measured from *Sense(+)* to *Sense(-)*, is the amount of IR drop being compensated by the regulator. This should be limited to 0.6V. (0.3V maximum between pins 17 & 18, and also between pins 8 & 9).

*Note: The remote sense feature is not designed to compensate for the forward drop of non-linear or frequency dependent components that may be placed in series with the converter output. Examples include OR-ing diodes, filter inductors, ferrite beads, and fuses. When these components are enclosed by the remote sense connections they are effectively placed inside the regulation control loop, which can adversely affect the stability of the regulator.*

### Over-Current Protection

To protect against load faults, the regulators incorporate output over-current protection. Applying a load that exceeds the regulator's over-current threshold (see data sheet specifications) will cause the regulated output to shut down. Following shutdown the ISR will periodically attempt to recover by initiating a soft-start power-up. This is often described as a "hiccup" mode of operation, whereby the module continues in the cycle of successive shutdown and power up until the load fault is removed. During this period, the average current flowing into the fault is significantly reduced. Once the fault is removed, the converter automatically recovers and returns to normal operation.

### Over-Temperature Protection

An on-board temperature sensor protects the module's internal circuitry against excessively high temperatures. A rise in the internal temperature may be the result of a drop in airflow, or a high ambient temperature. If the internal temperature exceeds the OTP threshold (see data sheet specifications), the regulator's *Inhibit\** control is automatically pulled low. This disables the regulator, allowing the output voltage to drop to zero as the external output capacitors are discharged by the load circuit. The recovery is automatic, and begins with a soft-start power up. It occurs when the the sensed temperature decreases by about 10°C below the trip point.

*Note: The over-temperature protection is a last resort mechanism to prevent thermal stress to the regulator. Operation at or close to the thermal shutdown temperature is not recommended and will reduce the long-term reliability of the module. Always operate the regulator within the specified Safe Operating Area (SOA) limits for the worst-case conditions of ambient temperature and airflow.*

### Startup of the PT5800 & PT5810 Series ISRs with Back-Feeding Source (Pre-Bias Capability)

In complex digital systems an external voltage can sometimes be present at the output of the regulator during power up. For example, this voltage may be backfed through a dual-supply logic component such as an FPGA or ASIC. Another path might be via a clamp diode (to a lower supply voltage) as part of a power-up sequencing implementation.

Although the PT5800 (5-V input) and PT5810 (3.3-V input) series of regulators will sink current under steady-state operating conditions, they will not do so during startup <sup>1</sup> as long as certain conditions are maintained <sup>2</sup>. This feature allows these regulators to start up while an external voltage is simultaneously applied to the output. Figure 2-1 is an application schematic that demonstrates this capability. The waveforms in Figure 2-2 show the behavior of the circuit as input power is applied. Note that the plot of the regulator output current ( $I_o$ ) is approximately zero up to the timestamp 'A', even though a voltage is initially backfed to the output via the 3.3-V input supply and diodes  $D_1$  &  $D_2$ . The regulator sources current <sup>3</sup> when it begins raising the output above the back-fed voltage to its nominal regulation value.

#### Notes

1. Startup includes both the application of a valid input source voltage, or the removal of a ground signal from the *Inhibit\** control (pin 2) with a valid input source applied. The output of the regulator is effectively off (tri-state), during the period that the *Inhibit\** control is held low.

2. To ensure that the regulator does not sink current, the input voltage must always be greater or equal to the output voltage throughout the power-up and power-down sequence.
3. If an external source backfeeding the regulator's output is greater than the nominal regulation voltage, the output will begin sinking current at the end of its soft-start power-up sequence. If this current exceeds the rated output, the module could be overstressed.

**Figure 2-2; Power-up Waveforms with Back-Feeding Source**

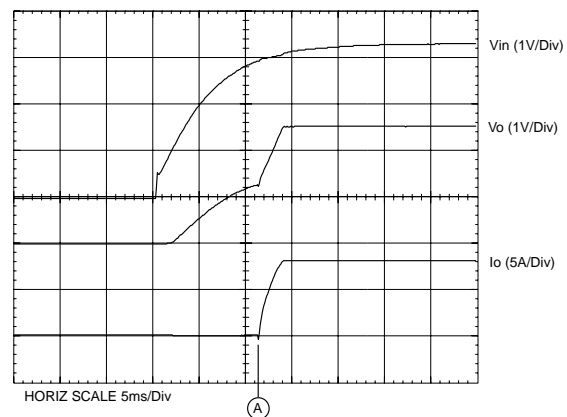

**Figure 2-1; Schematic Demonstrating Startup into Pre-Bias Capability**

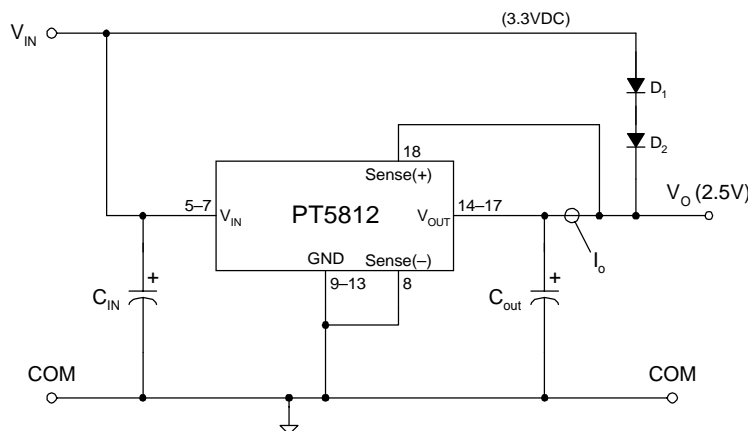

### Capacitor Recommendations for the PT5800 & PT5810 Step-Down Regulator Series

#### Input Capacitor:

The recommended input capacitance is determined by a 700-mA ripple current rating and the following minimum capacitance requirements.

- PT5800 = 820 $\mu$ F minimum capacitance
- PT5810 = 1000 $\mu$ F minimum capacitance

Ripple current and <100m $\Omega$  equivalent series resistance (ESR) values are the major considerations, along with temperature, when designing with different types of capacitors. Tantalum capacitors have a recommended minimum voltage rating of twice the maximum DC voltage + AC ripple. This is necessary to ensure reliability for input voltage bus applications

#### Output Capacitors

The ESR of the capacitors is less than 100m $\Omega$ . Electrolytic capacitors have marginal ripple performance at frequencies greater than 400kHz, but excellent low frequency transient response. Above the ripple frequency ceramic capacitors are necessary. Ceramic capacitors improve the transient response and reduce any high frequency noise components apparent during high current excursions. Preferred low-ESR electrolytic capacitor part numbers are identified in Table 3-1.

#### Tantalum Capacitors (Optional Output Capacitors)

Tantalum type capacitors can be used for the output but only the AVX TPS series, Sprague 593D/594/595 series, or Kemet T495/T510 series. These capacitors are recommended over many other tantalum types due to their higher rated surge, power dissipation, and ripple current capability. As a caution the TAJ series by AVX is not recommended. This series has considerably higher ESR, reduced power dissipation, and lower ripple current capability. The TAJ series is less reliable than the AVX TPS series when determining power dissipation capability. Tantalum or Oscon® types are recommended for applications where ambient temperatures fall below 0°C.

#### Capacitor Table

Table 2-1 identifies the characteristics of capacitors from a number of vendors with acceptable ESR and ripple current (rms) ratings. The number of capacitors required at both the input and output buses is identified for each capacitor type.

*This is not an extensive capacitor list. Capacitors from other vendors are available with comparable specifications. Those listed are for guidance. The RMS ripple current rating and ESR (Equivalent Series Resistance at 100kHz) are critical parameters necessary to insure both optimum regulator performance and long capacitor life.*

**Table 3-1; Input/Output Capacitors**

| Capacitor Vendor/Series                         | Capacitor Characteristics |                  |                                    |                                 |  | Quantity  |            | Vendor Part Number                                   |
|---|---------------------------|------------------|------------------------------------|---------------------------------|--|-----------|------------|--|
|   | Working Voltage           | Value ( $\mu$ F) | (ESR) Equivalent Series Resistance | Ripple Current I(rms)max @105°C | Physical Size (mm)                     | Input Bus | Output Bus |  |
| Panasonic<br>FC (Radial)<br>FK (SMT)            | 10V                       | 1000             | 0.068 $\Omega$                     | 1050mA                          | 10 $\times$ 16                         | 1         | 1          | EEUFC1C102<br>EEUFC1A561                             |
|   | 10V                       | 560              | 0.090 $\Omega$                     | 755mA                           | 10 $\times$ 12.5                       | 2         | 1          |  |
|   | 10V<br>35V                | 1000<br>470      | 0.080 $\Omega$<br>0.060 $\Omega$   | 850mA<br>1100mA                 | 10 $\times$ 10.2<br>12.5 $\times$ 13.5 | 1<br>2    | 1<br>1     | EUVFK1A102P<br>EUVFK1V471Q                           |
| United Chemi-con<br>LXZ/LXV Series<br>FX Series | 16V                       | 470              | 0.090 $\Omega$                     | 760mA                           | 10 $\times$ 12.5                       | 2         | 1          | LXZ16VB471M10X12LL<br>LXZ10VB102M10X16LL<br>10FX680M |
|   | 10V                       | 1000             | 0.068 $\Omega$                     | 1050mA                          | 10 $\times$ 16                         | 1         | 1          |  |
|   | 10V                       | 680              | 0.015 $\Omega$                     | 4735mA                          | 10 $\times$ 10.5                       | 2         | 1          |  |
| Nichicon<br>PL/PM Series<br>NX Series (SMT)     | 10V                       | 1000             | 0.065 $\Omega$                     | 1040mA                          | 12.5 $\times$ 15                       | 1         | 1          | UPM1A102MHH6<br>UPM1C 561MHH6<br>PNX1A330MCR1GS      |
|   | 16V                       | 560              | 0.080 $\Omega$                     | 920mA                           | 12.5 $\times$ 15                       | 2         | 1          |  |
|   | 10V                       | 330              | 0.024 $\Omega$                     | 3770mA                          | 10 $\times$ 8                          | 3         | 1          |  |
| Sanyo Os-con:<br>SP<br>SVP (SMT)                | 10V                       | 470              | 0.015 $\Omega$                     | >4500mA                         | 10 $\times$ 10.5                       | 2         | 1          | 10SP470M<br>10SVP560M                                |
|   | 10V                       | 560              | 0.013 $\Omega$                     | >5200mA                         | 11 $\times$ 12.7                       | 2         | 1          |  |
| AVX Tantalum TPS (SMT)                          | 10V                       | 470              | 0.045 $\Omega$                     | 1723mA                          | 7.3L                                   | 2         | 1          | TPSE477M010R0045<br>TPSV477M010R0060                 |
|   | 10V                       | 470              | 0.060 $\Omega$                     | 1826mA                          | $\times$ 5.7W<br>$\times$ 4.1H         | 2         | 1          |  |
| Kemet Polymer Tantalum<br>T520/T530Series (SMT) | 10V                       | 330              | 0.040 $\Omega$                     | 1800mA                          | 7.3 $\times$ 4.3 $\times$ 4            | 3         | 1          | T520X337M010AS<br>T530X337M010AS                     |
|   | 10V                       | 330              | 0.015 $\Omega$                     | >3800mA                         |  | 3         | 1          |  |
| Sprague Tantalum<br>594D Series (SMT)           | 10V                       | 680              | 0.090 $\Omega$                     | 1660mA                          | 7.2 $\times$ 6 $\times$ 4.1            | 2         | 1          | 595D687X0010R2T                                      |

### Using the Inhibit Control of the PT5800 & PT5810 Series of Step-Down ISRs

For applications requiring output voltage On/Off control, the PT5800 & PT5810 series of ISRs incorporate an inhibit function. This function can be used wherever there is a requirement for the output voltage from the ISR to be turned off. The On/Off function is provided by the *Inhibit\** control (pin 2).

The ISR functions normally with pin 2 open-circuit, providing a regulated output whenever a valid source voltage is applied between  $V_{in}$  (pins 5–7) and  $GND$  (pins 9–13). When a low-level ground signal is applied to pin 2, the regulator output is turned off <sup>2</sup>.

Figure 4-1 shows the typical application of the *Inhibit\** function. Note the discrete transistor ( $Q_1$ ). The *Inhibit\** control has its own internal pull-up to  $+V_{in}$  potential. An open-collector or open-drain device is recommended to control this input <sup>1</sup>. The voltage thresholds are given in Table 4-1.

**Table 4-1; Inhibit Control Requirements**

| Parameter            | Min             | Typ     | Max   |
|----------------------|-----------------|---------|-------|
| Enable ( $V_{IH}$ )  | $V_{in} - 0.5V$ | —       | Open  |
| Disable ( $V_{IL}$ ) | -0.2V           | —       | +0.8V |
| $I_{IL}$             | —               | -0.5 mA | —     |

**Figure 4-1**

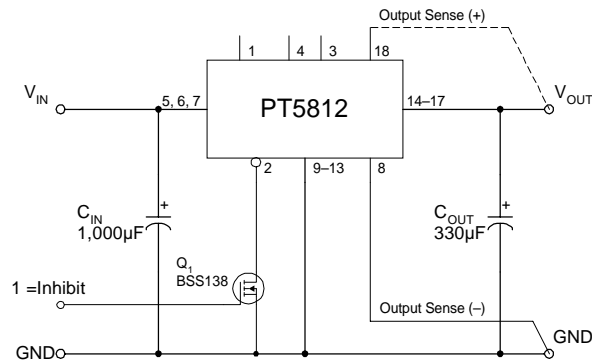

**Turn-On Time:** In the circuit of Figure 4-1, turning  $Q_1$  on applies a low-voltage to the *Inhibit\** control (pin 2) and disables the output of the regulator <sup>2</sup>. If  $Q_1$  is then turned off, the ISR executes a soft-start power up. Power up consists of a short delay (approx. 2msec), followed by a period in which the output voltage rises to its full regulation voltage. The module produces a regulated output voltage within 10msec. Figure 4-2 shows the typical rise in both the output voltage and input current for a PT5812 (2.5V), following the turn-off of  $Q_1$ . The turn off of  $Q_1$  corresponds to the rise in the waveform,  $Q_1 V_{ds}$ . The waveforms were measured with a 3.3VDC input voltage, and 10-A load.

**Figure 4-2**

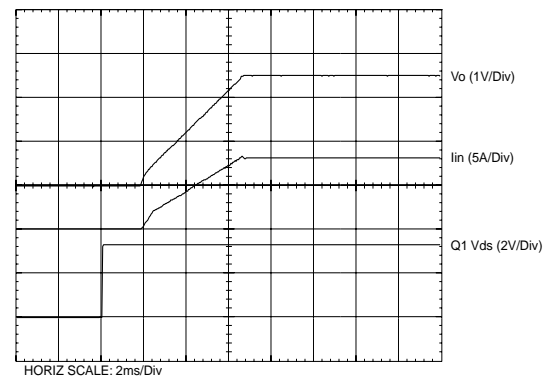

**Notes:**

1. Use an open-collector device with a breakdown voltage of at least 10V (preferably a discrete transistor) for the *Inhibit\** input. A pull-up resistor is not necessary. To disable the output voltage the control pin should be pulled low to less than +0.8VDC.
2. When a ground signal is applied to the *Inhibit\** control (pin 2) the module output is turned off (tri-state). The output voltage decays to zero as the load impedance discharges the output capacitors.

### Adjusting the Output Voltage of the PT5800 & PT5810 Step-Down Series of Regulators

#### Using Margin Up/ Margin Down

The *Margin Up\** (pin 4) and *Margin Dn\** (pin 3) control inputs allow the output voltage to be easily adjusted by up to  $\pm 5\%$  of the nominal set-point voltage. To activate, simply connect the appropriate control input to the *Sense(-)* (pin 8), or the local starpoint ground. Either a logic level MOSFET or a p-channel JFET is recommended for this purpose. For further information see the related application note on this feature.

#### Using the 'V<sub>o</sub> Adjust' Control

For a more permanent and precise adjustment, use the *V<sub>o</sub> Adjust* control (pin 1). The *V<sub>o</sub> Adjust* control allows adjustment in any increment by up to  $\pm 10\%$  of the set-point. The adjustment method requires the addition of a single external resistor. Table 5-1 gives the allowable adjustment range for each model of the series as *V<sub>a</sub>* (min) and *V<sub>a</sub>* (max). The value of the external resistor can either be calculated using the formulas given below, or simply selected from the range of values provided in Table 5-2. Refer to Figure 5-1 for the placement of the required resistor. Use the resistor *R<sub>1</sub>* to adjust up, and the resistor (*R<sub>2</sub>*) to adjust down.

**Adjust Up:** An increase in the output voltage is obtained by adding a resistor *R<sub>1</sub>*, between *V<sub>o</sub> Adjust* (pin 1) and *Sense(-)* (pin 8). See Figure 5-1.

**Adjust Down:** Add a resistor (*R<sub>2</sub>*), between *V<sub>o</sub> Adjust* (pin 1) and *Sense(+)* (pin 18). See Figure 5-1.

#### Notes:

1. Use a 1% (or better) tolerance resistor in either the *R<sub>1</sub>* or (*R<sub>2</sub>*) location. Place the resistor as close to the ISR as possible.
2. Never connect capacitors from *V<sub>o</sub> Adjust* to either *GND* or *V<sub>out</sub>*. Any capacitance added to the *V<sub>o</sub> Adjust* pin will affect the stability of the ISR.
3. If the remote sense feature is not being used, the adjust resistor (*R<sub>2</sub>*) can be connected to *V<sub>out</sub>*, (pins 14-17) instead of *Sense (+)*.

4. The PT5812 may not be adjusted higher than the nominal output voltage of 2.5V. There is insufficient input voltage between *V<sub>in</sub>* and *V<sub>out</sub>* to accommodate an increase in the output voltage.

#### V<sub>o</sub> Adjust Resistor Calculations

The values of *R<sub>1</sub>* [adjust up] and (*R<sub>2</sub>*) [adjust down] can also be calculated using the following formulas. Again, use Figure 5-1 for the placement of the required resistor; either *R<sub>1</sub>* or (*R<sub>2</sub>*) as appropriate.

$$R_1 = \frac{V_r \cdot R_o}{V_a - V_o} \quad - 24.9 \quad \text{k}\Omega$$

$$(R_2) = \frac{R_o (V_a - V_r)}{V_o - V_a} \quad - 24.9 \quad \text{k}\Omega$$

Where: *V<sub>o</sub>* = Original output voltage  
*V<sub>a</sub>* = Adjusted output voltage  
*V<sub>r</sub>* = The reference voltage in Table 5-1  
*R<sub>o</sub>* = The resistance constant in Table 5-1

**Figure 5-1; V<sub>o</sub> Adjust Resistor Placement**

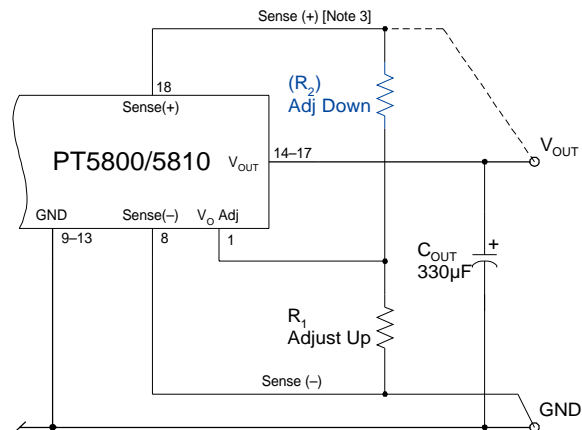

**Table 5-1**

**ISR OUTPUT VOLTAGE ADJUSTMENT RANGE AND FORMULA PARAMETERS**

| Series Pt. No.             | PT5801 | PT5802              | PT5803 | PT5804 | PT5805 | PT5806 |
|----------------------------|--------|---------------------|--------|--------|--------|--------|
| <b>5.0V Bus</b>            |        |                     |        |        |        |        |
| <b>3.3V Bus</b>            | N/A    | PT5812 <sup>4</sup> | PT5813 | PT5814 | PT5815 | PT5816 |
| <b>V<sub>o</sub> (nom)</b> | 3.3V   | 2.5V                | 1.8V   | 1.5V   | 1.2V   | 1.0V   |
| <b>V<sub>a</sub> (min)</b> | 2.6V   | 2.0V                | 1.52V  | 1.31V  | 1.1V   | 0.94V  |
| <b>V<sub>a</sub> (max)</b> | 3.63V  | 2.8V #              | 2.1V   | 1.82V  | 1.52V  | 1.32V  |
| <b>V<sub>r</sub></b>       | 0.8V   | 0.8V                | 0.8V   | 0.8V   | 0.8V   | 0.8V   |
| <b>R<sub>o</sub> (kΩ)</b>  | 10.2   | 10.7                | 10.2   | 9.76   | 10.0   | 10.2   |

# The PT5812 should not be adjusted higher than its nominal output voltage of 2.5V. See note 4.



PT5800 & PT5810 Series

Table 5-2

ISR ADJUSTMENT RESISTOR VALUES

| Series Pt. No.         |           |           |  |                        |           |           |          |
|------------------------|-----------|-----------|--|------------------------|-----------|-----------|----------|
| 5.0V Bus               | PT5801    | PT5802    |  | PT5803                 | PT5804    | PT5805    | PT5806   |
| 3.3V Bus               | N/A       | PT5812    |  | PT5813                 | PT5814    | PT5815    | PT5816   |
| V <sub>o</sub> (nom)   | 3.3V      | 2.5V      |  | 1.8V                   | 1.5V      | 1.2V      | 1.0V     |
| V <sub>a</sub> (req.d) |           |           |  | V <sub>a</sub> (req.d) |           |           |          |
| 3.60                   | 2.3kΩ     |           |  | 2.100                  | 2.3kΩ     |           |          |
| 3.55                   | 7.7kΩ     |           |  | 2.050                  | 7.7kΩ     |           |          |
| 3.50                   | 15.9kΩ    |           |  | 2.000                  | 15.9kΩ    |           |          |
| 3.45                   | 29.5kΩ    |           |  | 1.950                  | 29.5kΩ    |           |          |
| 3.40                   | 56.7kΩ    |           |  | 1.900                  | 56.7kΩ    |           |          |
| 3.35                   | 138.0kΩ   |           |  | 1.850                  | 138.0kΩ   |           |          |
| 3.30                   |           |           |  | 1.800                  |           | 1.1kΩ     |          |
| 3.25                   | (475.0)kΩ |           |  | 1.750                  | (169.0)kΩ | 6.3kΩ     |          |
| 3.20                   | (220.0)kΩ |           |  | 1.700                  | (66.9)kΩ  | 14.1kΩ    |          |
| 3.15                   | (135.0)kΩ |           |  | 1.650                  | (32.9)kΩ  | 27.2kΩ    |          |
| 3.10                   | (92.4)kΩ  |           |  | 1.600                  | (15.9)kΩ  | 53.2kΩ    |          |
| 3.05                   | (66.9)kΩ  |           |  | 1.550                  | (5.7)kΩ   | 131.0kΩ   |          |
| 3.00                   | (49.9)kΩ  |           |  | 1.500                  |           | 1.8kΩ     |          |
| 2.95                   | (37.5)kΩ  |           |  | 1.475                  | (239.0)kΩ | 4.2kΩ     |          |
| 2.90                   | (28.6)kΩ  |           |  | 1.450                  | (102.0)kΩ | 7.1kΩ     |          |
| 2.85                   | (21.6)kΩ  |           |  | 1.425                  | (56.4)kΩ  | 10.7kΩ    |          |
| 2.80                   | (15.9)kΩ  | 3.6KΩ     |  | 1.400                  | (33.7)kΩ  | 15.1kΩ    |          |
| 2.75                   | (11.3)kΩ  | 9.3KΩ     |  | 1.375                  | (20.0)kΩ  | 20.8kΩ    |          |
| 2.70                   | (7.4)kΩ   | 17.9KΩ    |  | 1.350                  | (10.9)kΩ  | 28.4kΩ    |          |
| 2.65                   | (4.1)kΩ   | 32.2KΩ    |  | 1.325                  | (4.4)kΩ   | 39.1kΩ    |          |
| 2.60                   | (1.3)kΩ   | 60.7KΩ    |  | 1.300                  |           | 55.1kΩ    | 2.3kΩ    |
| 2.550                  | [Note 4]  | 146.0KΩ   |  | 1.275                  |           | 81.8kΩ    | 4.8kΩ    |
| 2.500                  |           |           |  | 1.250                  |           | 135.0kΩ   | 7.7kΩ    |
| 2.450                  |           | (321.0)kΩ |  | 1.225                  |           | 295.0kΩ   | 11.4kΩ   |
| 2.400                  |           | (146.0)kΩ |  | 1.200                  |           |           | 15.9kΩ   |
| 2.350                  |           | (85.7)kΩ  |  | 1.175                  |           | (125.0)kΩ | 21.7kΩ   |
| 2.300                  |           | (55.3)kΩ  |  | 1.150                  |           | (45.1)kΩ  | 29.5kΩ   |
| 2.250                  |           | (37.2)kΩ  |  | 1.125                  |           | (18.4)kΩ  | 40.4kΩ   |
| 2.200                  |           | (25.0)kΩ  |  | 1.100                  |           | (5.1)kΩ   | 56.7kΩ   |
| 2.150                  |           | (16.4)kΩ  |  | 1.075                  |           |           | 83.9kΩ   |
| 2.100                  |           | (9.9)kΩ   |  | 1.050                  |           |           | 138.0kΩ  |
| 2.050                  |           | (4.8)kΩ   |  | 1.025                  |           |           | 302.0KΩ  |
| 2.000                  |           | (0.8)kΩ   |  | 1.000                  |           |           |          |
|                        |           |           |  | 0.975                  |           |           | (46.5)kΩ |
|                        |           |           |  | 0.950                  |           |           | (5.7)kΩ  |

R<sub>1</sub> = Black R<sub>2</sub> = (Blue)

### Using the Margin Up/Down Controls on the PT5800 & PT5810 Regulator Series

The PT5800 & PT5810 series of integrated switching regulator modules incorporate *Margin Up\** (pin 4) and *Margin Dn\** (pin 3) control inputs. These controls allow the output voltage set point to be momentarily adjusted 1, either up or down, by a nominal 5%. This provides a convenient method for dynamically testing the load circuit's power supply voltage over its operating margin or range. Note that the  $\pm 5\%$  change is also applied to any adjustment of the output voltage, if made, using the  $V_o$  *Adjust* (pin 1).

The 5% adjustment is made by driving the appropriate margin control input directly to the ground reference at *Sense(-)* (pin 8) <sup>2</sup>. An low-leakage open-drain device, such as a MOSFET or a p-channel JFET is recommended for this purpose. Adjustments of less than 5% can also be accommodated by adding series resistors to the control inputs (See Figure 6-1). The value of the resistor can be selected from Table 6-1, or calculated using the following formula.

#### Resistor Value Calculation

To reduce the margin adjustment to something less than 5%, series padding resistors are required (See  $R_D$  and  $R_U$  in Figure 6-1). For the same amount of adjustment, the resistor value calculated for  $R_U$  and  $R_D$  will be the same. The formulas is as follows.

$$R_U/R_D = \frac{499}{\Delta\%} - 99.8 \quad \text{k}\Omega$$

Where  $\Delta\%$  = The desired amount of margin adjust in percent.

#### Notes:

1. The *Margin Up\** and *Margin Dn\** controls were not intended to be activated simultaneously. If they are their affects on the output voltage may not completely cancel, resulting in a slight shift in the output voltage set point.
2. When possible use the *Sense(-)* (pin 8) as the ground reference. This will produce a more accurate adjustment of the output voltage at the load circuit terminals. *GND* (pins 9-13) can be used if the *Sense(-)* pin is connected to *GND* near the regulator.

**Table 6-1; Margin Up/Down Resistor Values**

| PADDING RESISTOR VALUES |                 |
|-------------------------|-----------------|
| % Adjust                | $R_U / R_D$     |
| 5                       | 0.0k $\Omega$   |
| 4                       | 24.9k $\Omega$  |
| 3                       | 66.5k $\Omega$  |
| 2                       | 150.0k $\Omega$ |
| 1                       | 397.0k $\Omega$ |

**Figure 6-1; Margin Up/Down Application Schematic**

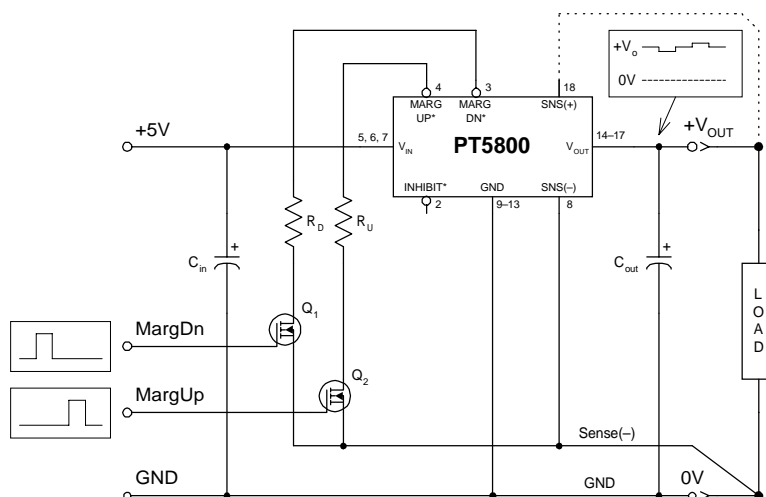

## IMPORTANT NOTICE

Texas Instruments Incorporated and its subsidiaries (TI) reserve the right to make corrections, modifications, enhancements, improvements, and other changes to its products and services at any time and to discontinue any product or service without notice. Customers should obtain the latest relevant information before placing orders and should verify that such information is current and complete. All products are sold subject to TI's terms and conditions of sale supplied at the time of order acknowledgment.

TI warrants performance of its hardware products to the specifications applicable at the time of sale in accordance with TI's standard warranty. Testing and other quality control techniques are used to the extent TI deems necessary to support this warranty. Except where mandated by government requirements, testing of all parameters of each product is not necessarily performed.

TI assumes no liability for applications assistance or customer product design. Customers are responsible for their products and applications using TI components. To minimize the risks associated with customer products and applications, customers should provide adequate design and operating safeguards.

TI does not warrant or represent that any license, either express or implied, is granted under any TI patent right, copyright, mask work right, or other TI intellectual property right relating to any combination, machine, or process in which TI products or services are used. Information published by TI regarding third-party products or services does not constitute a license from TI to use such products or services or a warranty or endorsement thereof. Use of such information may require a license from a third party under the patents or other intellectual property of the third party, or a license from TI under the patents or other intellectual property of TI.

Reproduction of information in TI data books or data sheets is permissible only if reproduction is without alteration and is accompanied by all associated warranties, conditions, limitations, and notices. Reproduction of this information with alteration is an unfair and deceptive business practice. TI is not responsible or liable for such altered documentation.

Resale of TI products or services with statements different from or beyond the parameters stated by TI for that product or service voids all express and any implied warranties for the associated TI product or service and is an unfair and deceptive business practice. TI is not responsible or liable for any such statements.

### Mailing Address:

Texas Instruments  
Post Office Box 655303  
Dallas, Texas 75265