



**MICROCHIP**

---

**BM64 Evaluation Board (EVB)  
User's Guide**

---

**Note the following details of the code protection feature on Microchip devices:**

- Microchip products meet the specification contained in their particular Microchip Data Sheet.
- Microchip believes that its family of products is one of the most secure families of its kind on the market today, when used in the intended manner and under normal conditions.
- There are dishonest and possibly illegal methods used to breach the code protection feature. All of these methods, to our knowledge, require using the Microchip products in a manner outside the operating specifications contained in Microchip's Data Sheets. Most likely, the person doing so is engaged in theft of intellectual property.
- Microchip is willing to work with the customer who is concerned about the integrity of their code.
- Neither Microchip nor any other semiconductor manufacturer can guarantee the security of their code. Code protection does not mean that we are guaranteeing the product as "unbreakable."

Code protection is constantly evolving. We at Microchip are committed to continuously improving the code protection features of our products. Attempts to break Microchip's code protection feature may be a violation of the Digital Millennium Copyright Act. If such acts allow unauthorized access to your software or other copyrighted work, you may have a right to sue for relief under that Act.

---

Information contained in this publication regarding device applications and the like is provided only for your convenience and may be superseded by updates. It is your responsibility to ensure that your application meets with your specifications. MICROCHIP MAKES NO REPRESENTATIONS OR WARRANTIES OF ANY KIND WHETHER EXPRESS OR IMPLIED, WRITTEN OR ORAL, STATUTORY OR OTHERWISE, RELATED TO THE INFORMATION, INCLUDING BUT NOT LIMITED TO ITS CONDITION, QUALITY, PERFORMANCE, MERCHANTABILITY OR FITNESS FOR PURPOSE. Microchip disclaims all liability arising from this information and its use. Use of Microchip devices in life support and/or safety applications is entirely at the buyer's risk, and the buyer agrees to defend, indemnify and hold harmless Microchip from any and all damages, claims, suits, or expenses resulting from such use. No licenses are conveyed, implicitly or otherwise, under any Microchip intellectual property rights unless otherwise stated.

*Microchip received ISO/TS-16949:2009 certification for its worldwide headquarters, design and wafer fabrication facilities in Chandler and Tempe, Arizona; Gresham, Oregon and design centers in California and India. The Company's quality system processes and procedures are for its PIC® MCUs and dsPIC® DSCs, KEELOQ® code hopping devices, Serial EEPROMs, microperipherals, nonvolatile memory and analog products. In addition, Microchip's quality system for the design and manufacture of development systems is ISO 9001:2000 certified.*

**QUALITY MANAGEMENT SYSTEM  
CERTIFIED BY DNV  
= ISO/TS 16949 =**

**Trademarks**

The Microchip name and logo, the Microchip logo, AnyRate, AVR, AVR logo, AVR Freaks, BeaconThings, BitCloud, CryptoMemory, CryptoRF, dsPIC, FlashFlex, flexPWR, Heldo, JukeBlox, KEELOQ, KEELOQ logo, Kleer, LANCheck, LINK MD, maXStylus, maXTouch, MediaLB, megaAVR, MOST, MOST logo, MPLAB, OptoLyzer, PIC, picoPower, PICSTART, PIC32 logo, Prochip Designer, QTouch, RightTouch, SAM-BA, SpyNIC, SST, SST Logo, SuperFlash, tinyAVR, UNI/O, and XMEGA are registered trademarks of Microchip Technology Incorporated in the U.S.A. and other countries.

ClockWorks, The Embedded Control Solutions Company, EtherSynch, Hyper Speed Control, HyperLight Load, IntelliMOS, mTouch, Precision Edge, and Quiet-Wire are registered trademarks of Microchip Technology Incorporated in the U.S.A.

Adjacent Key Suppression, AKS, Analog-for-the-Digital Age, Any Capacitor, AnyIn, AnyOut, BodyCom, chipKIT, chipKIT logo, CodeGuard, CryptoAuthentication, CryptoCompanion, CryptoController, dsPICDEM, dsPICDEM.net, Dynamic Average Matching, DAM, ECAN, EtherGREEN, In-Circuit Serial Programming, ICSP, Inter-Chip Connectivity, JitterBlocker, KleerNet, KleerNet logo, Mindi, MiWi, motorBench, MPASM, MPF, MPLAB Certified logo, MPLIB, MPLINK, MultiTRAK, NetDetach, Omniscient Code Generation, PICDEM, PICDEM.net, PICKit, PICtail, PureSilicon, QMatrix, RightTouch logo, REAL ICE, Ripple Blocker, SAM-ICE, Serial Quad I/O, SMART-I.S., SQI, SuperSwitcher, SuperSwitcher II, Total Endurance, TSHARC, USBCheck, VariSense, ViewSpan, WiperLock, Wireless DNA, and ZENA are trademarks of Microchip Technology Incorporated in the U.S.A. and other countries.

SQTP is a service mark of Microchip Technology Incorporated in the U.S.A.

Silicon Storage Technology is a registered trademark of Microchip Technology Inc. in other countries.

GestIC is a registered trademark of Microchip Technology Germany II GmbH & Co. KG, a subsidiary of Microchip Technology Inc., in other countries.

All other trademarks mentioned herein are property of their respective companies.

© 2016-2018, Microchip Technology Incorporated, All Rights Reserved.

ISBN: 978-1-5224-2765-0



## BM64 EVB USER'S GUIDE

Object of Declaration  
BM64 Evaluation Board

Manufacturer: Microchip Technology Inc.  
2355 W. Chandler Blvd.  
Chandler, Arizona, 85224-6199  
USA

This declaration of conformity is issued by the manufacturer.

The development/evaluation tool is designed to be used for research and development in a laboratory environment. This development/evaluation tool is not a Finished Appliance, nor is it intended for incorporation into Finished Appliances that are made commercially available as single functional units to end users under EU EMC Directive 2004/108/EC and as supported by the European Commission's Guide for the EMC Directive 2004/108/EC (8<sup>th</sup> February 2010).

This development/evaluation tool complies with EU RoHS2 Directive 2011/65/EU.

This development/evaluation tool, when incorporating wireless and radio-telecom functionality, is in compliance with the essential requirement and other relevant provisions of the R&TTE Directive 1999/5/EC and the FCC rules as stated in the declaration of conformity provided in the module datasheet and the module product page available at [www.microchip.com](http://www.microchip.com).

For information regarding the exclusive, limited warranties applicable to Microchip products, please see Microchip's standard terms and conditions of sale, which are printed on our sales documentation and available at [www.microchip.com](http://www.microchip.com).

Signed for and on behalf of Microchip Technology Inc. at Chandler, Arizona, USA

  
Derek Carlson

12-Sep-14  
Date

# BM64 EVB User's Guide

---

NOTES:



---

---

**Table of Contents**

---

---

**Chapter 1. Introduction**

1.1 Kit Contents ..... 13  
1.2 BM64 EVB Features ..... 15

**Chapter 2. Hardware**

2.1 Hardware Features ..... 17

**Chapter 3. Getting Started**

3.1 Requirements ..... 23  
3.2 Getting Started with BM64 EVB ..... 24  
3.3 Application Demonstration ..... 25  
3.4 Configuring BM64 Module ..... 27  
3.5 Updating EEPROM Parameters ..... 50  
3.6 Updating Flash Code ..... 56  
3.7 Updating MCU Parameters ..... 64  
A.1 Reference Schematics ..... 69

# BM64 EVB User's Guide

---

---

NOTES:

---

---

## Preface

---

---

### NOTICE TO CUSTOMERS

All documentation becomes dated, and this manual is no exception. Microchip tools and documentation are constantly evolving to meet customer needs, so some actual dialogs and/or tool descriptions may differ from those in this document. Please refer to our web site ([www.microchip.com](http://www.microchip.com)) to obtain the latest documentation available.

Documents are identified with a “DS” number. This number is located on the bottom of each page, in front of the page number. The numbering convention for the DS number is “DSXXXXXXXXA”, where “XXXXXXXX” is the document number and “A” is the revision level of the document.

For the most up-to-date information on development tools, see the MPLAB® X IDE online help. Select the Help menu, and then Topics to open a list of available online help files.

## INTRODUCTION

This chapter contains general information that will be useful to know before using the BM64 Evaluation Board (EVB). Items discussed in this chapter include:

- [Document Layout](#)
- [Conventions Used in this Guide](#)
- [Recommended Reading](#)
- [The Microchip Web Site](#)
- [Development Systems Customer Change Notification Service](#)
- [Customer Support](#)
- [Document Revision History](#)

## DOCUMENT LAYOUT

This document describes how to use the BM64 EVB, as a development tool to emulate and debug firmware on a target board. This user's guide is composed of the following chapters:

- **Chapter 1. “Introduction”** provides an overview of the BM64 EVB and its features.
- **Chapter 2. “Hardware”** provides hardware details of the BM64 EVB.
- **Chapter 3. “Getting Started”** provides information about how to establish the Bluetooth® connection using the BM64 EVB and how to configure the BM64 module using various tools.
- **Appendix A. “Schematics”** provides the BM64 EVB reference schematics.

# BM64 EVB User's Guide

## CONVENTIONS USED IN THIS GUIDE

This manual uses the following documentation conventions:

### DOCUMENTATION CONVENTIONS

Description	Represents	Examples
Italic characters	Referenced books	<i>MPLAB IDE User's Guide</i>
	Emphasized text	...is the <i>only</i> compiler...
Initial caps	A window	the Output window
	A dialog	the Settings dialog
	A menu selection	select Enable Programmer
Quotes	A field name in a window or dialog	"Save project before build"
Underlined, italic text with right angle bracket	A menu path	<u><i>File &gt; Save</i></u>
Bold characters	A dialog button	Click <b>OK</b>
	A tab	Click the <b>Power</b> tab
Text in angle brackets < >	A key on the keyboard	Press <Enter>, <F1>
Plain Courier New	Sample source code	#define START
	Filenames	autoexec.bat
	File paths	c:\mcc18\h
	Keywords	_asm, _endasm, static
	Command-line options	-Opa+, -Opa-
	Bit values	0, 1
	Constants	0xFF, 'A'
<i>Italic Courier New</i>	A variable argument	<i>file.o</i> , where <i>file</i> can be any valid filename
Square brackets [ ]	Optional arguments	mcc18 [options] <i>file</i> [options]
Curly brackets and pipe character: {   }	Choice of mutually exclusive arguments; an OR selection	errorlevel {0 1}
Ellipses...	Replaces repeated text	var_name [, var_name...]
	Represents code supplied by user	void main (void) { ... }
Notes	A Note presents information that we want to re-emphasize, either to help you avoid a common pitfall or to make you aware of operating differences between some device family members. A Note can be in a box, or when used in a table or figure, it is located at the bottom of the table or figure.	<b>Note:</b> This is a standard note box.
		<b>CAUTION</b> <b>This is a caution note.</b> <b>Note 1:</b> This is a note used in a table.



## RECOMMENDED READING

This user's guide describes how to use the BM64 EVB. The following Microchip document is available and recommended as supplemental reference resources.

### **BM62/64 Data Sheet (DS60001403)**

Refer to this document for detailed information on BM64 module. Reference information found in this data sheet includes:

- BM64 module features and pin configurations
- Electrical Specifications
- Reference Circuits

## THE MICROCHIP WEB SITE

Microchip provides online support via our web site at: <http://www.microchip.com>. This web site makes files and information easily available to customers. Accessible by most Internet browsers, the web site contains the following information:

- **Product Support** – Data sheets and errata, application notes and sample programs, design resources, user's guides and hardware support documents, latest software releases and archived software
- **General Technical Support** – Frequently Asked Questions (FAQs), technical support requests, online discussion groups, Microchip consultant program member listings
- **Business of Microchip** – Product selector and ordering guides, latest Microchip press releases, listings of seminars and events; and listings of Microchip sales offices, distributors and factory representatives

## DEVELOPMENT SYSTEMS CUSTOMER CHANGE NOTIFICATION SERVICE

Microchip's customer notification service helps keep customers current on Microchip products. Subscribers will receive e-mail notification whenever there are changes, updates, revisions or errata related to a specified product family or development tool of interest.

To register, access the Microchip web site at [www.microchip.com](http://www.microchip.com), click on Customer Change Notification and follow the registration instructions.

The Development Systems product group categories are:

- **Compilers** – The latest information on Microchip C compilers and other language tools
- **Emulators** – The latest information on the Microchip in-circuit emulator, MPLAB REAL ICE™
- **In-Circuit Debuggers** – The latest information on the Microchip in-circuit debugger, MPLAB ICD 3
- **MPLAB X IDE** – The latest information on Microchip MPLAB X IDE, the Windows® Integrated Development Environment for development systems tools
- **Programmiers** – The latest information on Microchip programmers including the PICkit™ 3 development programmer

## CUSTOMER SUPPORT

Users of Microchip products can receive assistance through several channels:

- Distributor or Representative
- Local Sales Office
- Field Application Engineer (FAE)
- Technical Support

Customers should contact their distributor, representative or Field Application Engineer (FAE) for support. Local sales offices are also available to help customers. A listing of sales offices and locations is included in the back of this document.

Technical support is available through the web site at: <http://support.microchip.com>.

## DOCUMENT REVISION HISTORY

### **Revision A (June 2016)**

This is the initial released version of this document.

### **Revision B (March 2018)**

This revision includes the following updates:

- Updated [3.2 “Getting Started with BM64 EVB”](#)
- Updated [Figure 3-9](#) and [Figure 3-11](#)
- Added [Figure 3-12](#) and [Figure 3-13](#)

Minor updates to text and formatting were incorporated throughout the document.

# BM64 EVB User's Guide

---

NOTES:

---

---

## Chapter 1. Introduction

---

---

Thank you for purchasing a BM64 Evaluation Board (EVB). This document provides detailed information about the Microchip BM64 EVB.

The BM64 EVB enables the user to evaluate and demonstrate the functionalities of the BM64 module. The BM64 EVB includes status LEDs and an integrated configuration and programming interface for plug-and-play capability, which enables rapid prototyping and faster time to market.

Along with the BM64 EVB, software tools and applications are provided to demonstrate the Bluetooth connections to the on-board BM64 module with options for configuring or programming it.

This chapter includes the following topics:

[1.1 “Kit Contents”](#)

[1.2 “BM64 EVB Features”](#)

### 1.1 KIT CONTENTS

The BM64 EVB kit includes the following items, as illustrated in [Figure 1-1](#):

- One BM64 EVB, which contains the BM64SPKS1MC1 module
- One micro-USB cable
- One 15V DC power adapter
- Two speaker cables

# BM64 EVB User's Guide

FIGURE 1-1: BM64 EVB KIT CONTENTS



**Note:** If you are missing any part of the BM64 EVB kit, contact a Microchip sales office for assistance. A list of Microchip offices for sales and service is provided on the back page of this document.

## 1.2 BM64 EVB FEATURES

The following are key features of the BM64 EVB:

- The BM64 EVB includes a BM64 module, qualified for Bluetooth 4.2 specifications
- On-board MCU (PIC18F85J10) and DSP (YDA174) for easy operation and feature demonstration
- On-board keypad matrix that is controlled by MCU, which makes it easy for playback control
- Built-in Near Field Communication (NFC)
- RoHS compliant

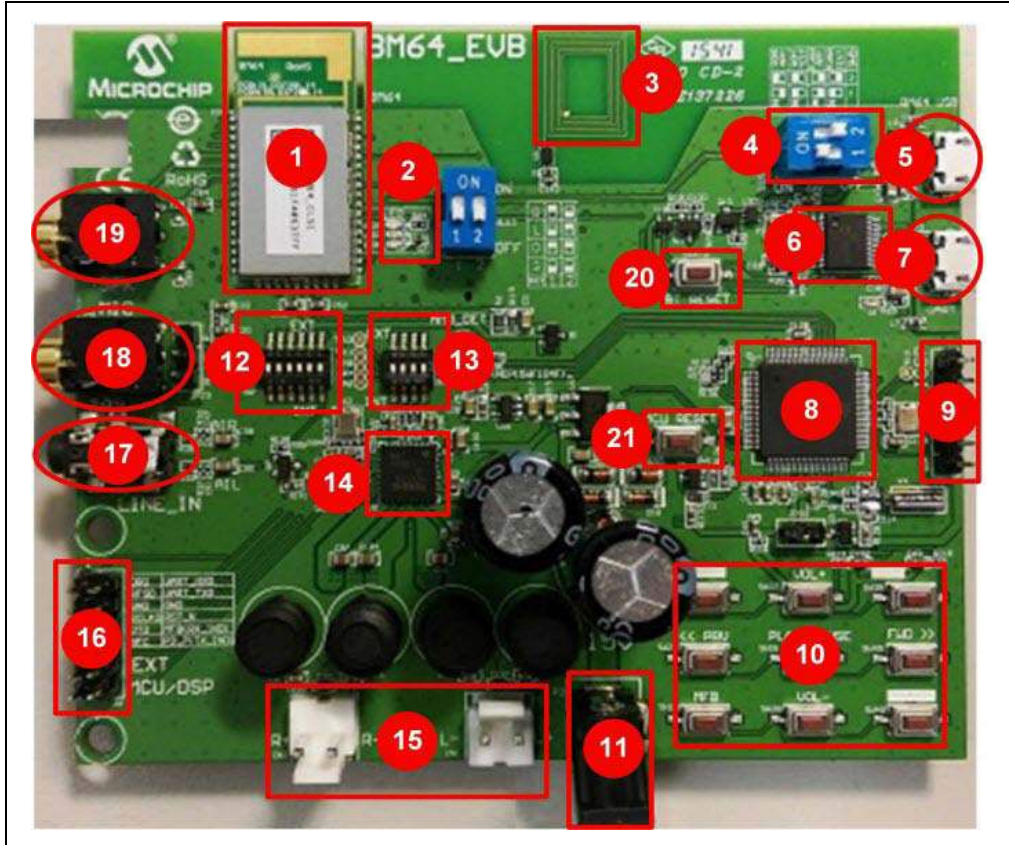
[Figure 1-1](#) illustrates the top view of the BM64 EVB with the following components:

1. BM64SPKS1MC1 module
2. Three status LEDs
3. NFC tag
4. Mode switch (SW9)
5. USB connector (P9)
6. USB to UART converter (MCP2200)
7. UART port over USB connector (P3)
8. MCU (PIC18F85J10)
9. ICSP header (J5)
10. Audio control buttons, Multi-Function Button (MFB) and pairing mode button
11. 15V adapter jack (P2)
12. Internal/External MCU selection switch (SW46)
13. Internal/External DSP selection switch (SW47)
14. On-board DSP (YDA174) with built-in audio amplifier
15. Audio connector (CN1 and CN2)
16. External MCU/DSP header (J6)
17. Auxiliary input 3.5 mm jack (P8)
18. Microphone input 3.5 mm jack (P6)
19. Speaker output 3.5 mm jack (P7)
20. Reset button for BM64 module (SW10)
21. Reset button for MCU (SW1)

For more details on the features, refer to the [Chapter 2. “Hardware”](#).

# BM64 EVB User's Guide

FIGURE 1-1: BM64 EVB (TOP VIEW)

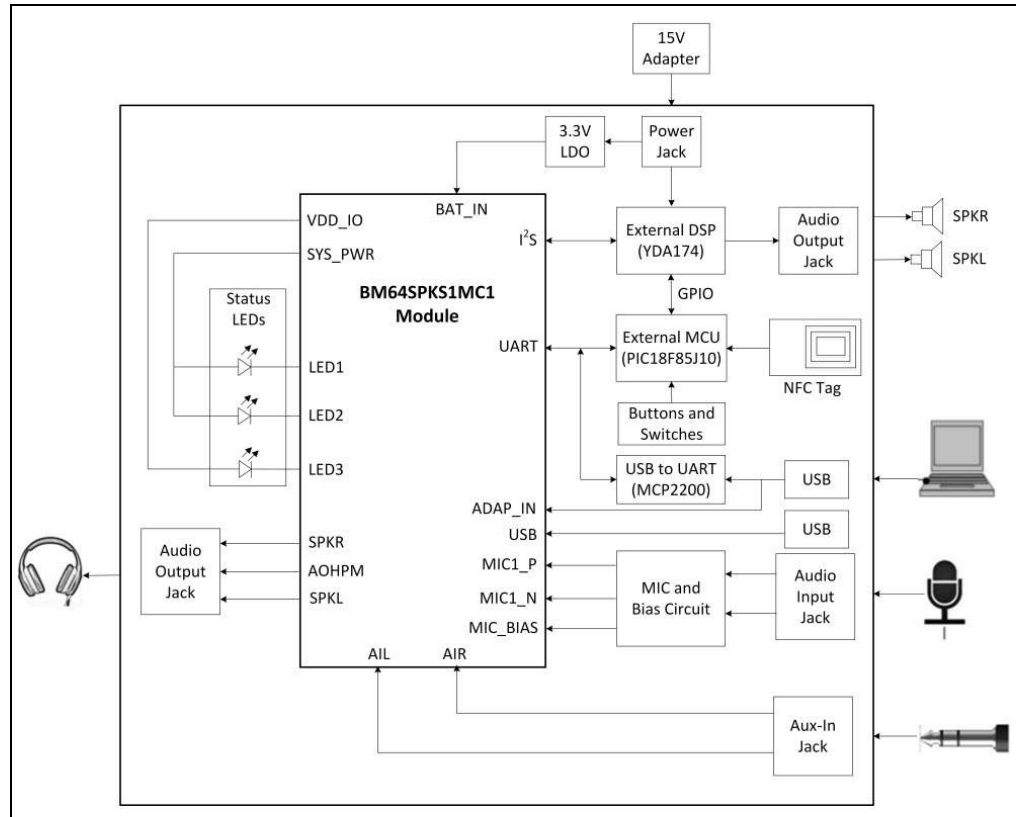




**Chapter 2. Hardware**

This chapter describes the hardware features of the BM64 EVB. The BM64 EVB includes a range of peripheral components, see [Figure 2-1](#).

**FIGURE 2-1: BM64 EVB BLOCK DIAGRAM**



**2.1 HARDWARE FEATURES**

The following list provides the details of each component in the BM64 EVB. For detailed information about the location of these components, refer to [Figure 1-1](#).

**2.1.1 Power Supply**

The 15V DC power adapter supplies power to the BM64 EVB.

**2.1.2 USB connectivity**

The BM64 EVB has two USB ports that can be connected to the host PC using a micro-USB cable:

- Debug/program port (P3), where the USB signals are converted to/from the UART by the MCP2200
- USB port (P9), where USB signals are directly connected to BM64 module

## 2.1.3 Switches and Push Buttons

The functions of the switches and push buttons on the BM64 EVB are:

- SW1 – Reset button for the MCU
- SW9 – Mode switch
- SW10 – Reset button for BM64 module
- SW23 – Skip the audio track backward
- SW24 (MFB) – Push button to turn on/off the BM64 module
- SW27 – Increase volume
- SW28 – Decrease volume
- SW31 – Play or pause the audio playback
- SW40 – Button to enter into pairing mode
- SW45 – Skip the audio track forward

[Table 2-1](#) provides the settings of Mode switch SW9 to configure the BM64 module in various operating modes.

**TABLE 2-1: SWITCH SW9 DETAILS**





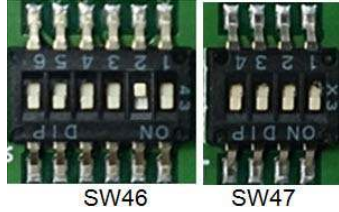
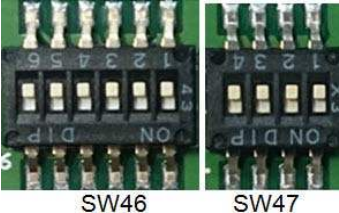
Mode	Switch Positions	Pin Definition
Flash Test Mode		1: ON (P2_0: LOW) 2: OFF (EAN: LOW)
Flash Application Mode		1: OFF (P2_0: HIGH) 2: OFF (EAN: LOW)
ROM Test Mode		1: ON (P2_0: LOW) 2: ON (EAN: HIGH)
ROM Application Mode		1: OFF (P2_0: HIGH) 2: ON (EAN: HIGH)

Table 2-2 details the signals and button connections of the SW46/SW47 switch to the BM64 module and the external MCU/DSP.

**TABLE 2-2: SWITCH SW46/SW47 DETAILS**

Mode	SW46/SW47 Switch position	Pin Definition
On-board MCU (PIC18F85J10) and DSP audio amplifier (YDA174) signals connection to the BM64 module (default)		<b>SW46</b> 1: ON (NFC trigger to MCU) 2: OFF (TXIND to MCU) 3: ON (RST_N to MCU) 4: ON (HCI_TXD to MCU) 5: ON (HCI_RXD to MCU) 6: ON (MFB controlled by MCU) <b>SW47</b> 1: ON (DT0 to DSP) 2: ON (SCLK0 to DSP) 3: ON (RFS0 to DSP) 4: ON (NC)
External MCU and DSP audio amplifier connection		<b>SW46</b> 1: OFF (NFC trigger) 2: OFF (TXIND) 3: OFF (RST_N) 4: OFF (HCI_TXD) 5: OFF (HCI_RXD) 6: OFF (MFB) <b>SW47</b> 1: OFF (DT0) 2: OFF (SCLK0) 3: OFF (RFS0) 4: OFF (NC)

## 2.1.4 LEDs

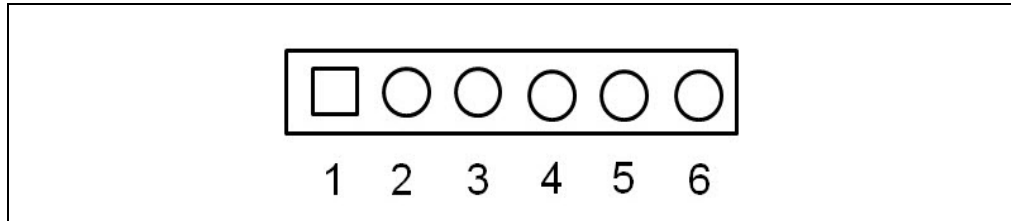
The functions of three LEDs are listed as follows:

- LED1 – Indicates the Bluetooth connection status (UI configuration dependent)
- LED2 – Indicates the Bluetooth connection status (UI configuration dependent)
- LED3 – Charging indication LED (default setting is disabled)

## 2.1.5 Jumpers and Headers

The following jumpers and headers (J5, J6, JP23) are available on the BM64 EVB. ICSP header J5 provides the programming/debugging interface for the BM64 EVB. [Figure 2-2](#) illustrates ICSP header J5 and [Table 2-3](#) provides the pin details and description.

**FIGURE 2-2: ICSP HEADER J5**

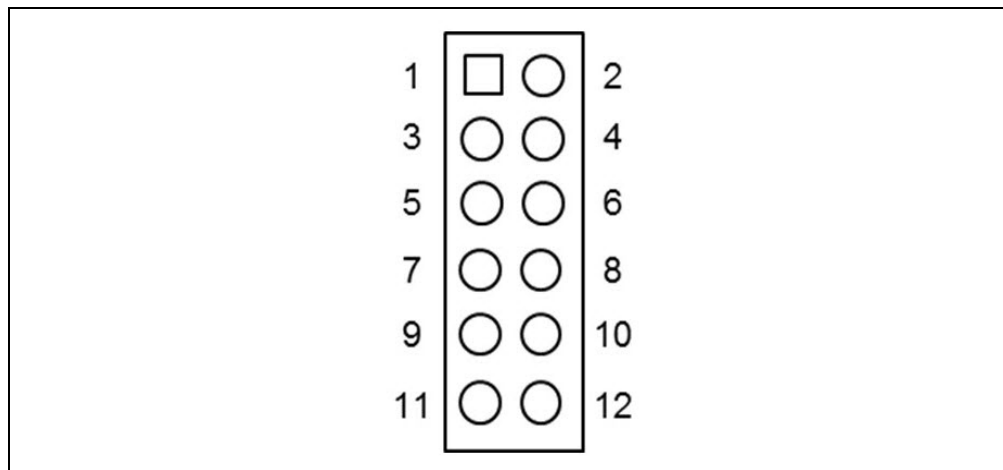


**TABLE 2-3: ICSP HEADER J5**

Part Number	Pin	Description
J5	1	Reset
	2	MPLAB ICD 3 power
	3	GND
	4	PGD
	5	PGC
	6	NC

The external MCU/DSP header J6 provides the interface to connect an external MCU/DSP to the BM64 EVB. [Figure 2-3](#) illustrates external MCU/DSP header J6 and [Table 2-4](#) provides the pin details and description.

**FIGURE 2-3: EXTERNAL MCU/DSP HEADER J6**



**TABLE 2-4: EXTERNAL MCU/DSP HEADER J6**

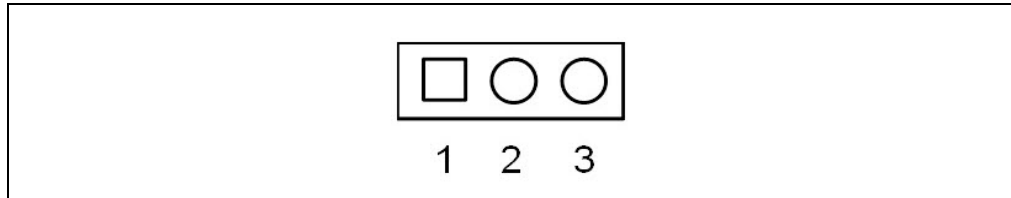
Part Number	Pin	Description
J6	1	I <sup>2</sup> S_DR
	2	UART_RXD
	3	I <sup>2</sup> S_RFS
	4	UART_TXD
	5	GND
	6	GND
	7	I <sup>2</sup> S_SCLK
	8	RST_N
	9	I <sup>2</sup> S_DT
	10	RX_IND
	11	NFC
	12	TX_IND

# BM64 EVB User's Guide

---

MIC header JP23 is used for connecting a microphone to the BM64 EVB. [Figure 2-4](#) illustrates MIC header JP23 and [Table 2-5](#) provides the pin details and description.

**FIGURE 2-4: MIC JP23**



**TABLE 2-5: MIC JP23**

Part Number	Pin	Description
JP23	1	MIC_P1
	2	AGND
	3	MIC_N1

---

---

## Chapter 3. Getting Started

---

---

This chapter describes how to establish Bluetooth connection between the BM64 EVB and a host device. It also demonstrates the process of updating the parameters using various tools.

This chapter includes the following topics:

- 3.1 “Requirements”**
- 3.2 “Getting Started with BM64 EVB”**
- 3.3 “Application Demonstration”**
- 3.4 “Configuring BM64 Module”**
- 3.5 “Updating EEPROM Parameters”**
- 3.6 “Updating Flash Code”**
- 3.7 “Updating MCU Parameters”**

### 3.1 REQUIREMENTS

The following hardware and software components are required for getting started with the BM64 EVB.

#### 3.1.1 Hardware Requirements

- BM64 EVB
- Bluetooth enabled smartphone:
  - Android™ device running Android 4.3 or later version
  - iOS: iPhone® 4S or later version
- Windows® host PC with USB port
- Speaker, microphone or headset
- Micro-USB cable
- MPLAB REAL ICE/MPLAB ICD 3/PICKit™ 3

#### 3.1.2 Software Requirements

Download the latest firmware and corresponding tools from the Microchip web site at: [www.microchip.com/BM64](http://www.microchip.com/BM64).

- User Interface tool
- DSP tool
- Mass Production EEPROM Tool (MPET)
- Firmware update tool
- Flash code
- EEPROM tool
- MPLAB® Integrated Development Environment (MPLAB X IDE) tool

**Note:** MPLAB X IDE is available for download from the Microchip web site at: [www.microchip.com/mplab/mplab-x-ide](http://www.microchip.com/mplab/mplab-x-ide).

# BM64 EVB User's Guide

## 3.2 GETTING STARTED WITH BM64 EVB

The BM64 EVB is preprogrammed with dual-mode software where Advanced Audio Distribution Profile (A2DP) and Bluetooth Low Energy (BLE) can be operated simultaneously. The MCU (PIC18F85J10, U13) on the BM64 EVB is also preprogrammed to work with dual-mode software. To establish the Bluetooth connection between the BM64 EVB and a host device, perform the following actions:

1. Set switch SW9 to Flash Application mode, see [Figure 3-1](#).

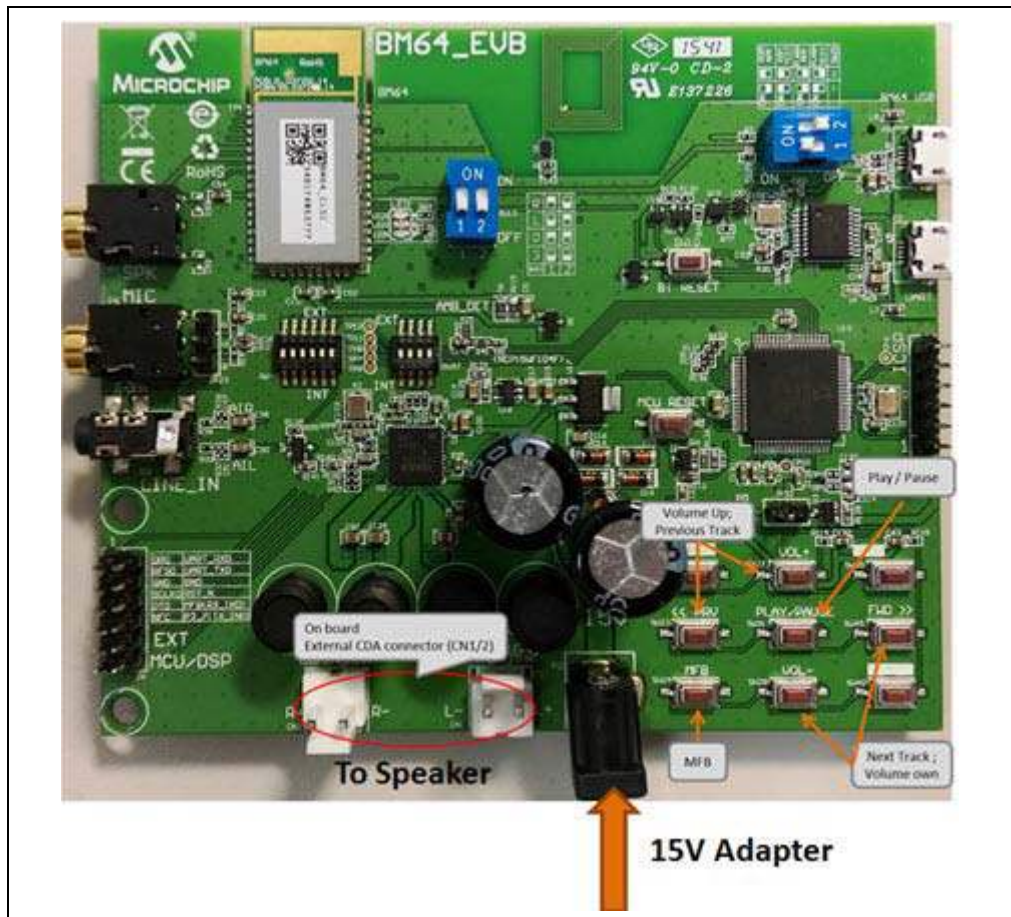
**FIGURE 3-1: SW9 IN FLASH APPLICATION MODE**



2. Connect the speaker line to the amplifier output connector (CN1 and CN2).
3. Connect the 15V DC power adapter to P2, as illustrated in [Figure 3-2](#).

**Note:** Do not plug-in the USB cable.

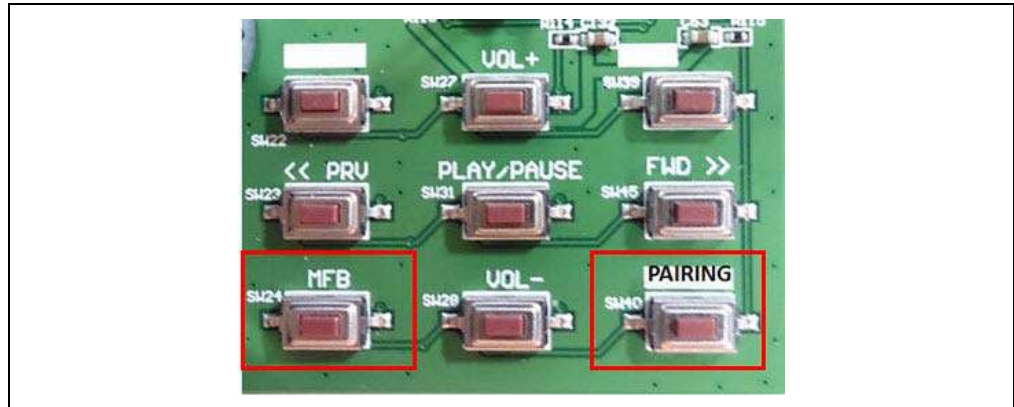
**FIGURE 3-2: USING THE EVALUATION BOARD**





4. [Figure 3-3](#) illustrates the various push buttons on the BM64 EVB. Long press SW24 (MFB) (approximately 5 seconds) to turn the Bluetooth on. Both LED1 (blue) and LED2 (red) will blink together, and later only LED1 (blue) will blink once at regular intervals.
5. Long press SW40 (pairing key) to enter pairing mode (depending on the UART command settings from the MCU to the Bluetooth module). LED1 (blue) and LED2 (red) will blink alternatively to indicate that the BM64 EVB is in discoverable mode.

**FIGURE 3-3: SW24 AND SW40**



6. Turn on the Bluetooth on a host device (PC or smartphone) and it will display a list of discoverable Bluetooth devices. The BM64 EVB is displayed as “Dual\_SPK” or “LE\_Dual\_SPK”. Select the device to establish the connection.

**Note:** The “Dual\_SPK” is used for the Bluetooth classic, and the “LE\_Dual\_SPK” is used for the BLE devices.

7. The LED1 (blue) blinks faster. This indicates the BM64 EVB is paired with the host device.
8. Once the connection is established, LED1 (blue) will blink twice at regular intervals. It will display as “connected” in the Bluetooth settings of the smartphone. With the default settings, the BM64 module enables Advanced Audio Distribution Profile (A2DP) for audio playback and Audio Video Remote Control Profile (AVRCP) for player control.

## 3.3 APPLICATION DEMONSTRATION

### 3.3.1 Audio Demonstration

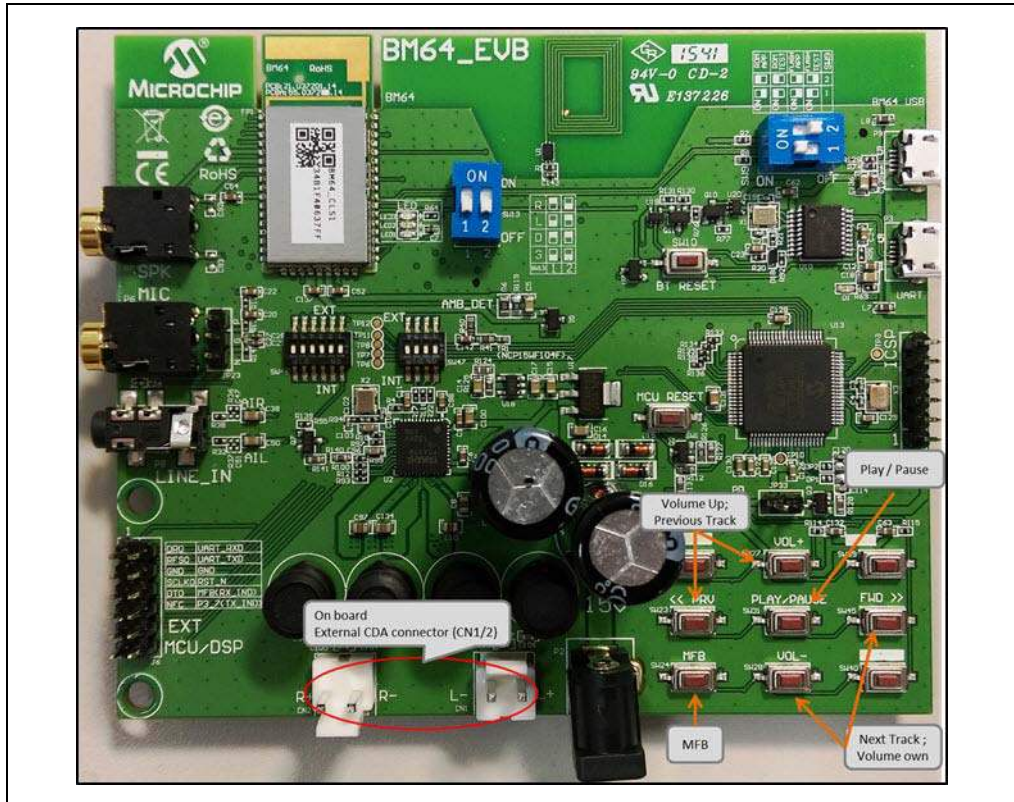
In this demonstration, the user can stream audio on the BM64 EVB using a host device (PC or smartphone). Perform the following actions for the audio demonstration, refer to [Figure 3-4](#).

1. Establish the connection between the BM64 EVB and a host device using the procedure listed in [3.2 “Getting Started with BM64 EVB”](#).
2. Once the connection between the BM64 EVB and the host device is established, open the audio source on the host device. Microchip recommends using a media player (for example: Windows® Media Player, iTunes®, and Android™).

# BM64 EVB User's Guide

3. Start the audio stream on the media player. Both LED1 (blue) and LED2 (red) will blink once at regular intervals during the audio playback. The audio control buttons are used for these functions:
  - To control the audio output volume (long press **VOL+** or **VOL-** button)
  - Go to the previous track (short press **<< PRV** button)
  - Go to the next track (short press **FWD >>** button)
  - Start/stop playing the current track (short press **PLAY/PAUSE** button)

**FIGURE 3-4: BM64 EVB AUDIO CONTROL BUTTONS**



## 3.3.2 HSP/HFP Demonstration

In this demonstration, the user can explore the Headset Profile (HSP) or Hands-Free Profile (HFP) setting to receive an incoming voice call from a paired smartphone. Perform the following steps for demonstration, refer to [Figure 3-4](#).

1. Establish the connection between the BM64 EVB and a host device using the procedure listed in [3.2 “Getting Started with BM64 EVB”](#).
2. Connect the speaker to the audio out connector (CN1 and CN2) and a microphone to the MIC input (P6), respectively, on the BM64 EVB.
3. Initiate a call from another phone to the smartphone that is paired with the BM64 EVB. The A2DP stream pauses and the ringtone is played on the speaker. LED1 (blue) blinks three times at regular intervals.
4. Press the SW24 (MFB) button on the BM64 EVB to accept the incoming call. LED1 (blue) and LED2 (red) will blink three times at regular intervals.

## 3.4 CONFIGURING BM64 MODULE

The BM64 EVB can be configured and various parameters can be customized using the UI tool and DSP tool, and then parameters are saved in a file. Using the MPET tool, the saved files are merged into the \*.ipf file, and then this merged file is programmed into the EEPROM. After EEPROM is programmed, restart the device to see the effect of the customized parameters.

### 3.4.1 UI Tool Configuration

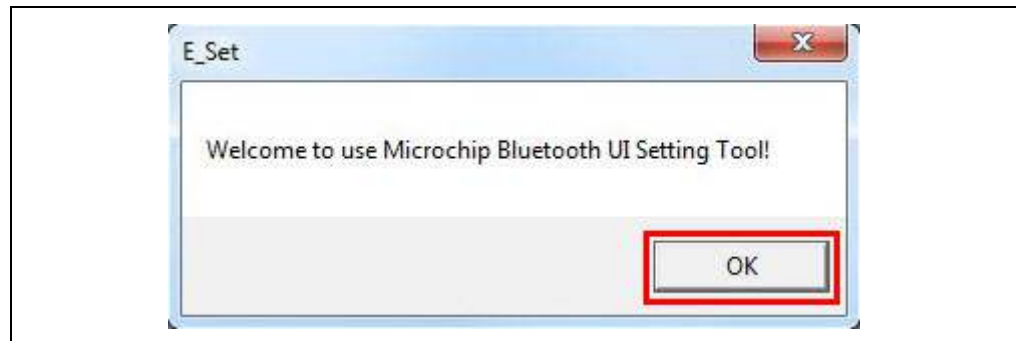
The User Interface (UI) tool is a configuration tool which enables the user to change the BM64 module parameters, such as device name, enable/disable pairing mode, BLE connection settings, configure the LEDs and enable/disable battery functions.

To configure the UI parameters, perform the following actions:

1. Open the UI configuration tool and click **OK** to configure the UI parameters, see [Figure 3-5](#).

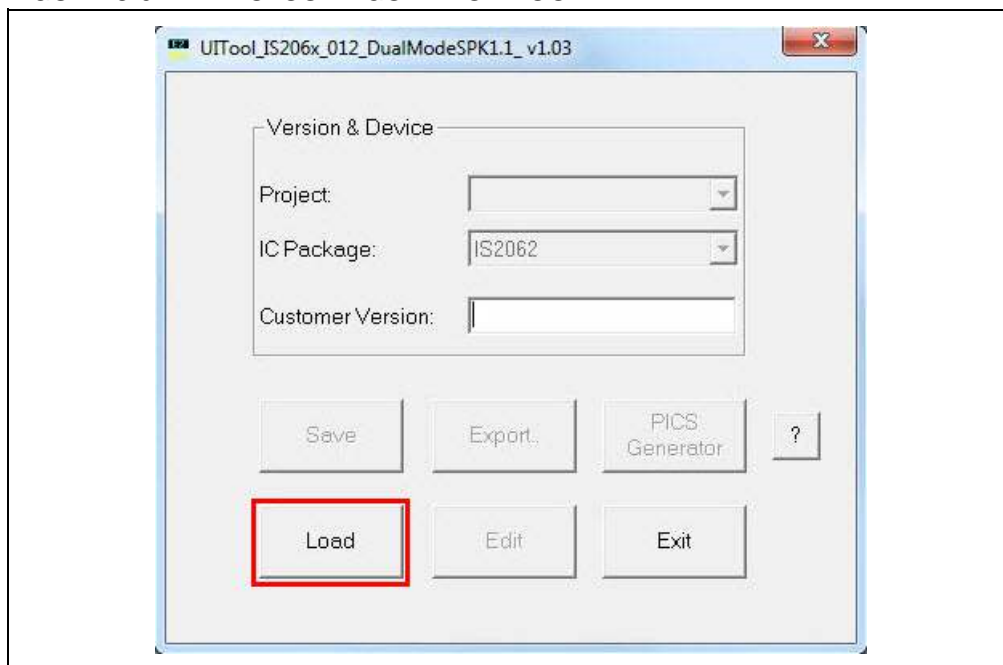
**Note:** Download and install the UI tool, which is available on the Microchip web site: [www.microchip.com/BM64](http://www.microchip.com/BM64). For this demonstration UITool\_IS206x\_012\_DualModeSPK1.1\_v1.03 is used.

**FIGURE 3-5: UI TOOL**



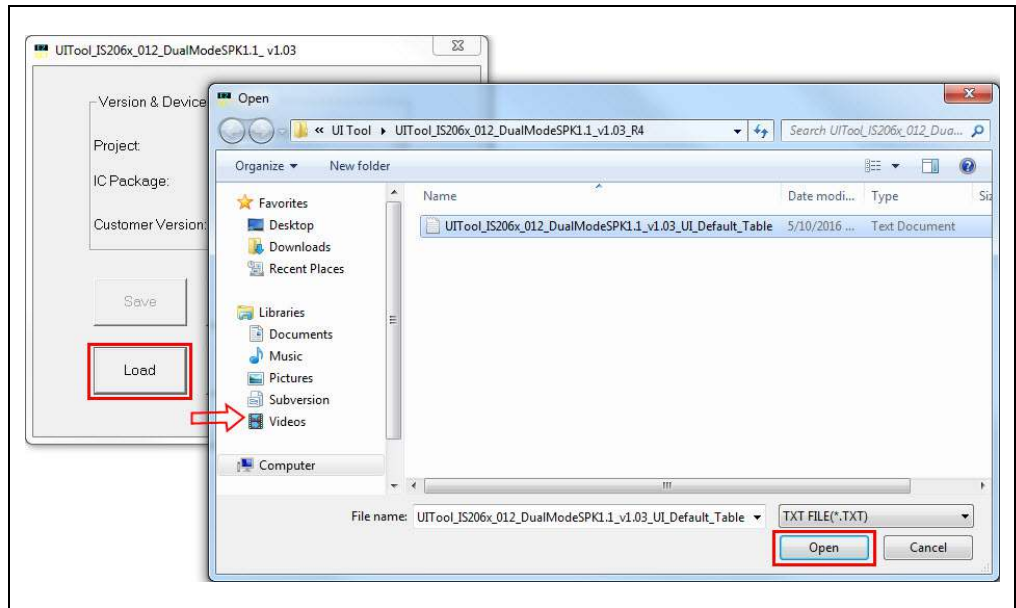
2. In the UI configuration tool, click **Load**, see [Figure 3-6](#).

**FIGURE 3-6: UI CONFIGURATION TOOL**



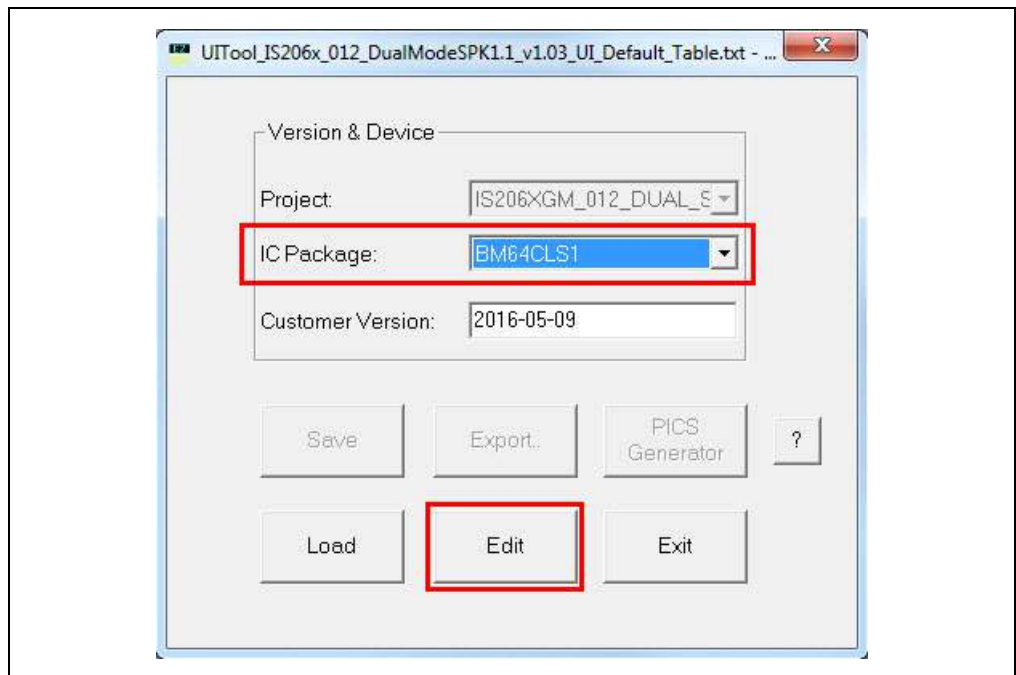
- From the Open window, select the default UI parameters text file (provided with the UI tool) for the BM64 module, and then click **Open**, see [Figure 3-7](#).

**FIGURE 3-7: LOADING DEFAULT UI PARAMETERS**



- After loading the UI parameters, select "BM64CLS1" from the **IC Package** dropdown list and then click **Edit**, see [Figure 3-8](#).

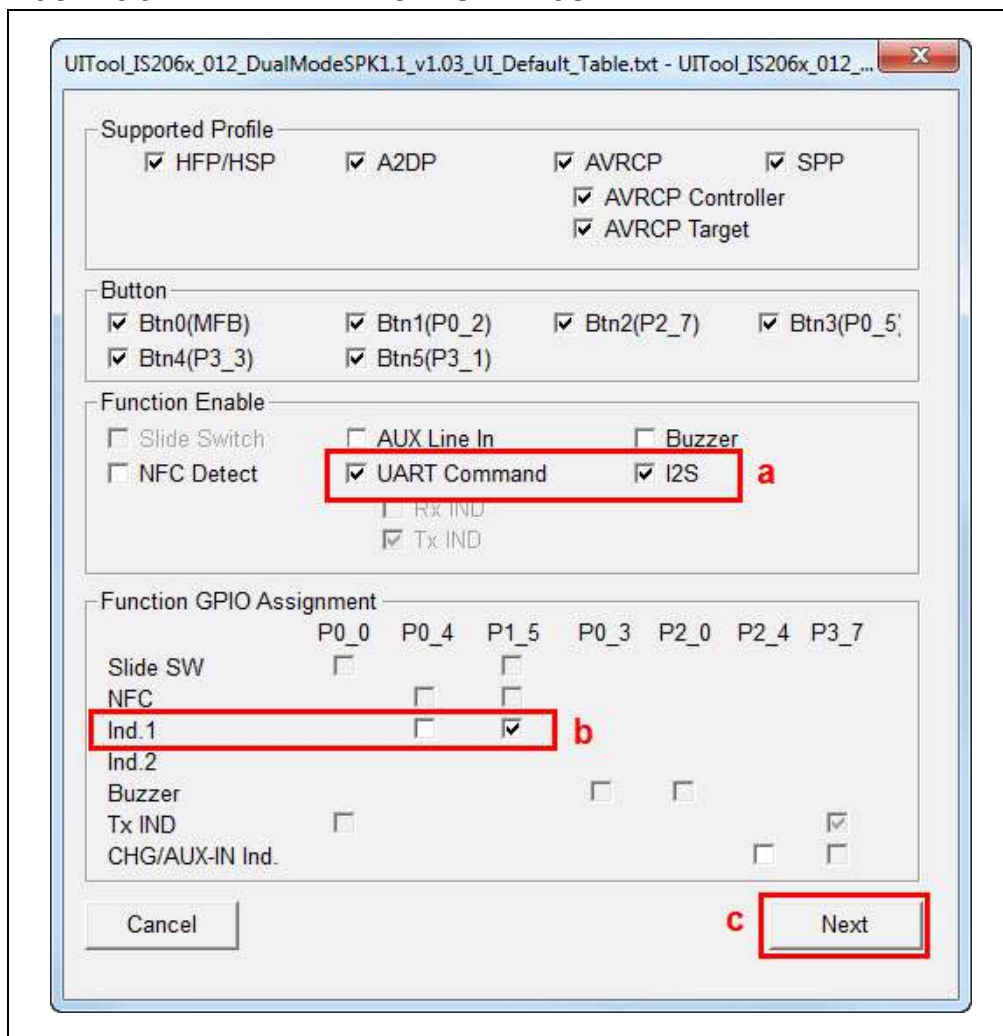
**FIGURE 3-8: EDIT UI PARAMETERS**



# BM64 EVB User's Guide

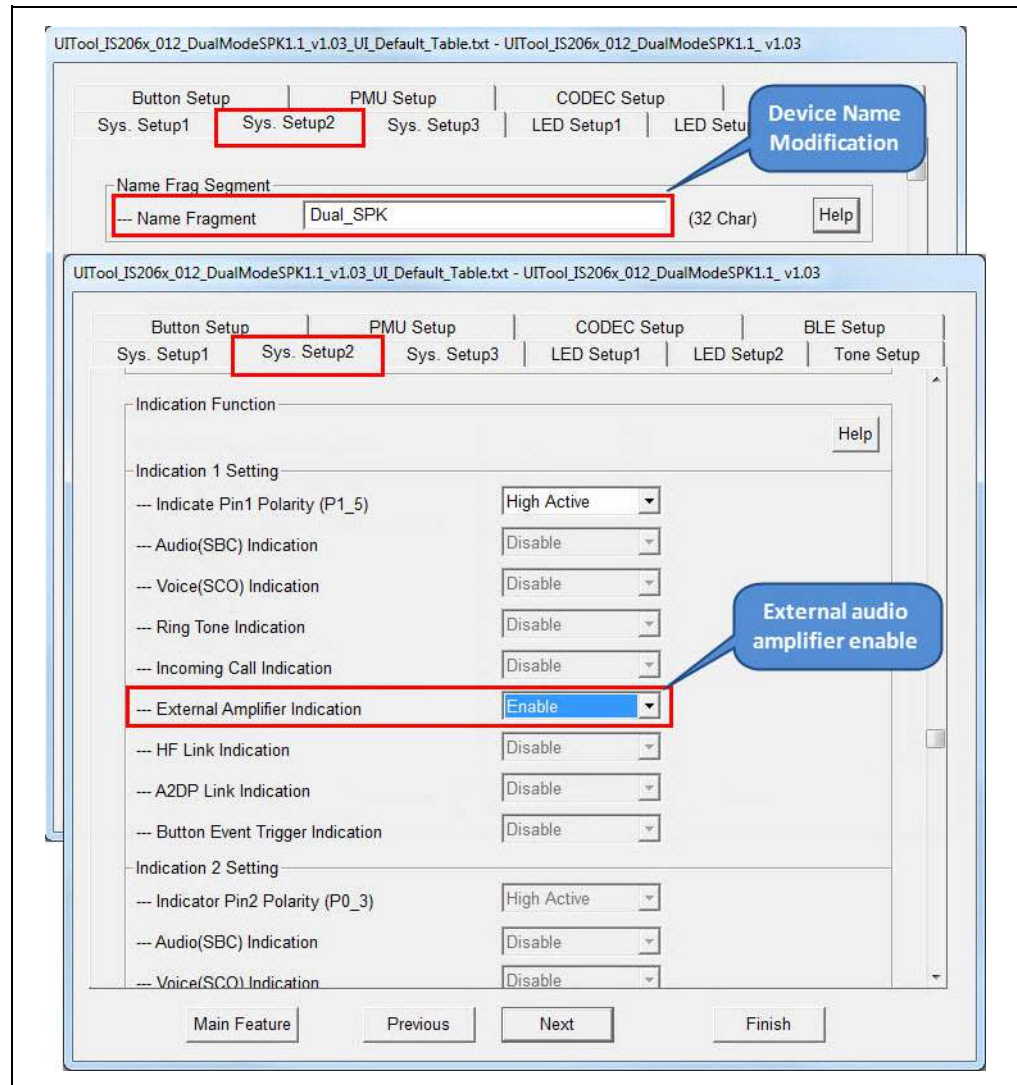
5. In the Main Feature dialog, the user can enable or disable the **Supported Profile** and audio line-in function **Button** and set the following parameters, as illustrated in [Figure 3-9](#).
  - a) Select the “UART Command” check box, which allows the module to be controlled by the MCU through the UART interface.
  - b) Select “I<sup>2</sup>S” check box for the volume key to function.
  - c) Select the “Ind.1” check box to enable the external audio amplifier.
  - d) Click **Next**.

**FIGURE 3-9: MAIN FEATURE SETTINGS**



- The System and Functional Settings dialog with various options (tabs) is displayed to configure the parameters. In the **Sys. Setup2** tab, from the Indication 1 Setting section, enable **External Amplifier Indication**, as illustrated in Figure 3-10. Click **Help** to get more detailed information.

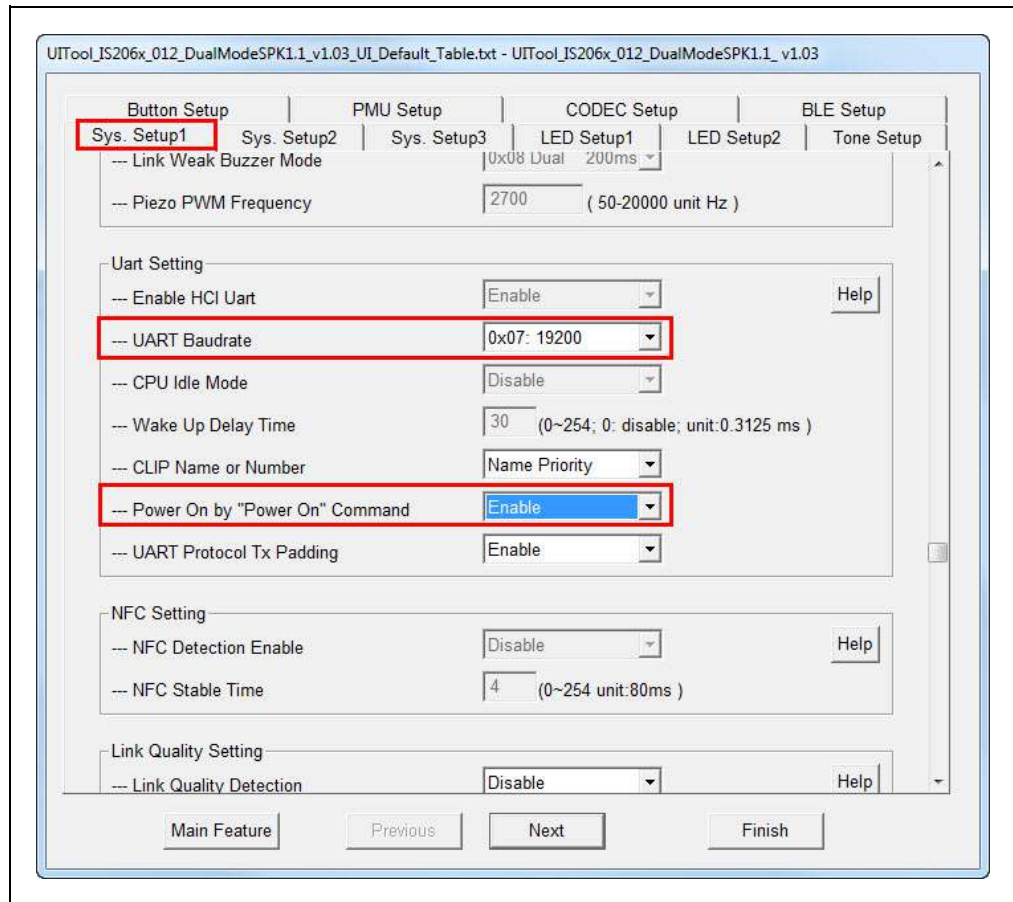
**FIGURE 3-10: ENABLE EXTERNAL AMPLIFIER INDICATION**



# BM64 EVB User's Guide

7. In the **Sys. Setup1** tab, from the UART Setting section, set the **UART Baudrate** to "0x07:19200" and then enable **Power On by "Power On" Command**, as illustrated in [Figure 3-11](#). The module will power-on by the UART command and not by the MFB key.

**FIGURE 3-11: UART COMMAND SETTING**

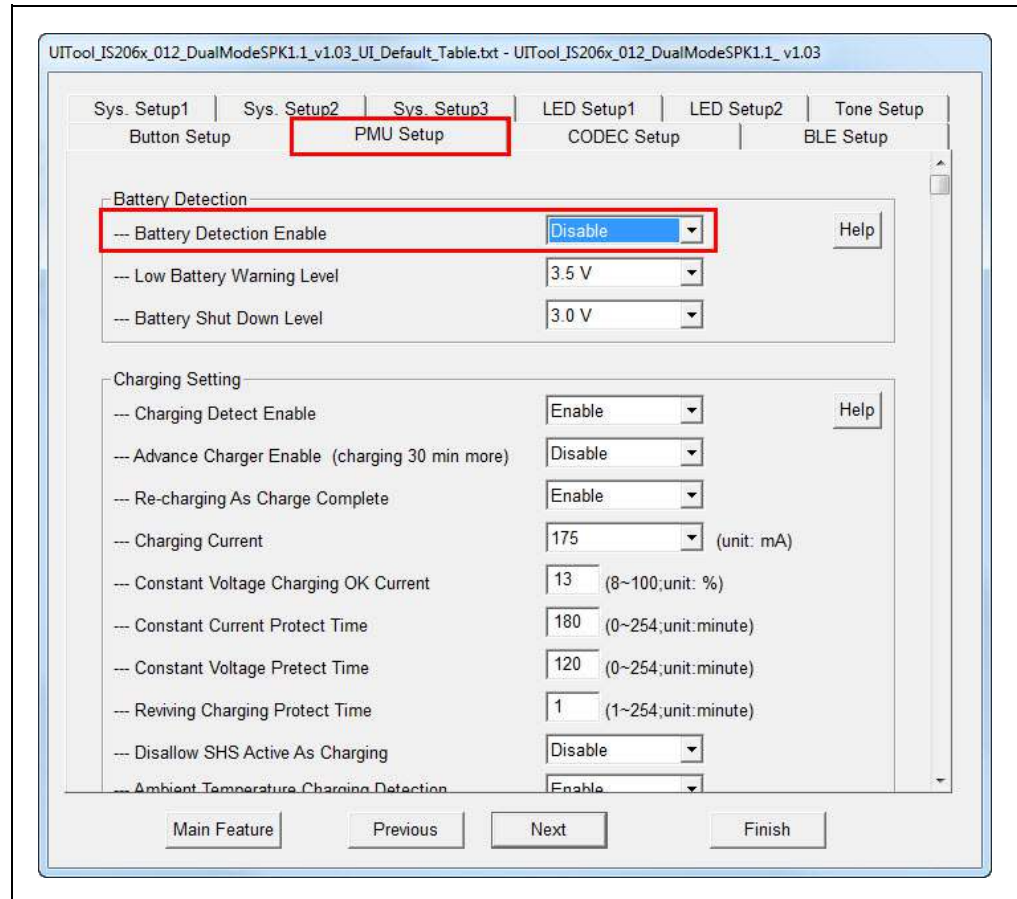


**Note:** As the MCU baud rate is set to 19200, the UI baud rate is also set to 19200.



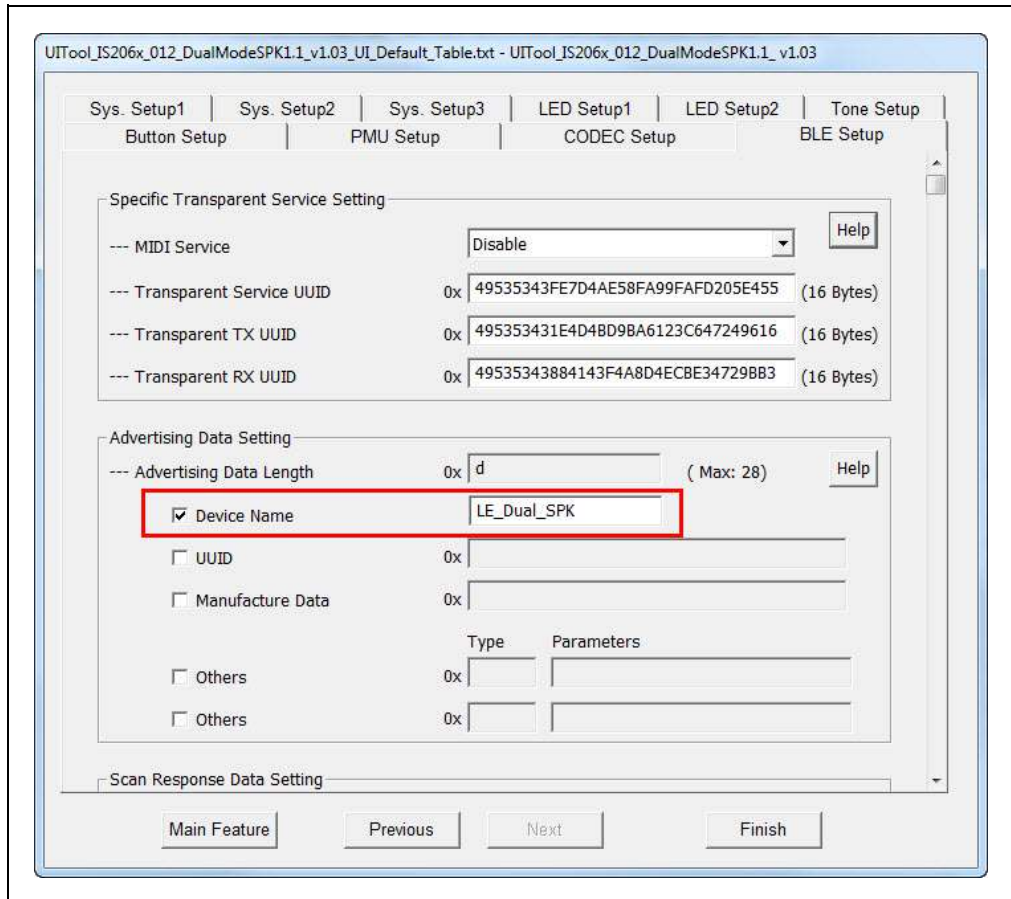
8. In the **PMU Setup** tab, from the Battery Detection section, disable **Battery Detection Enable**, as illustrated in [Figure 3-12](#).

**FIGURE 3-12: PMU SETUP**



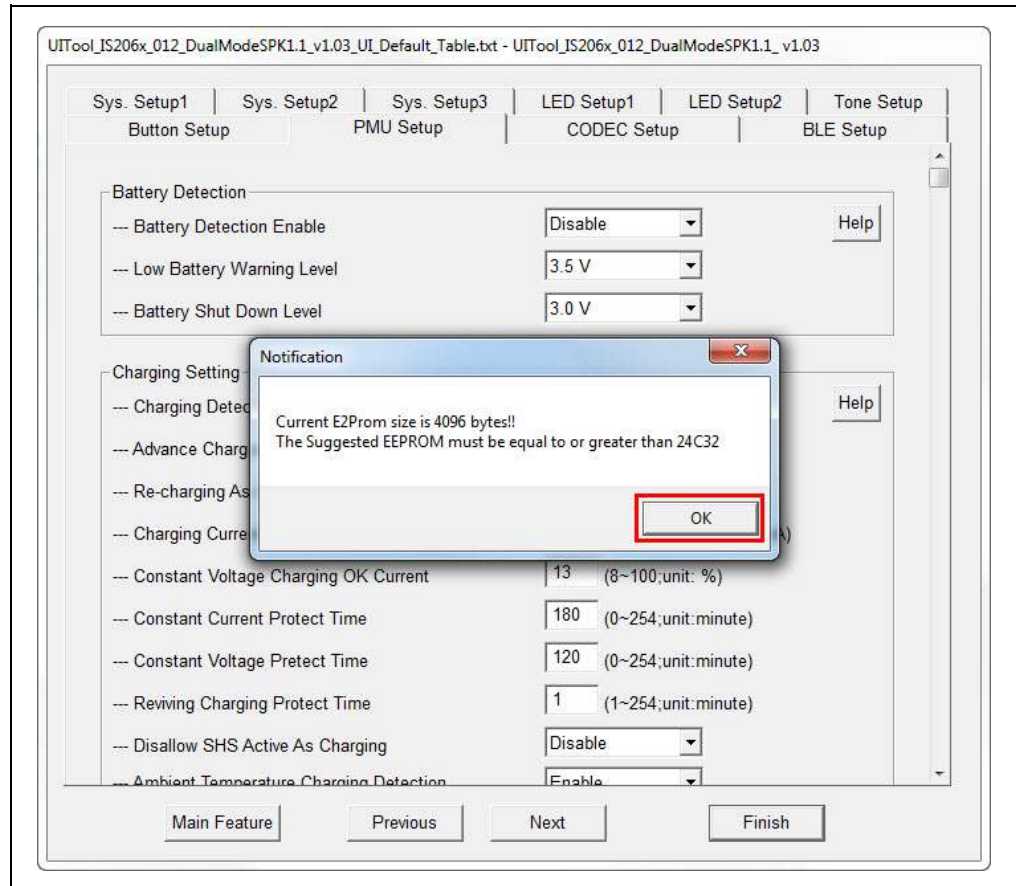
9. In the **BLE Setup** tab, from the Advertising Data Length section, select “Device Name” check box to advertise the device name, as illustrated in [Figure 3-13](#).

**FIGURE 3-13: BLE SETUP**



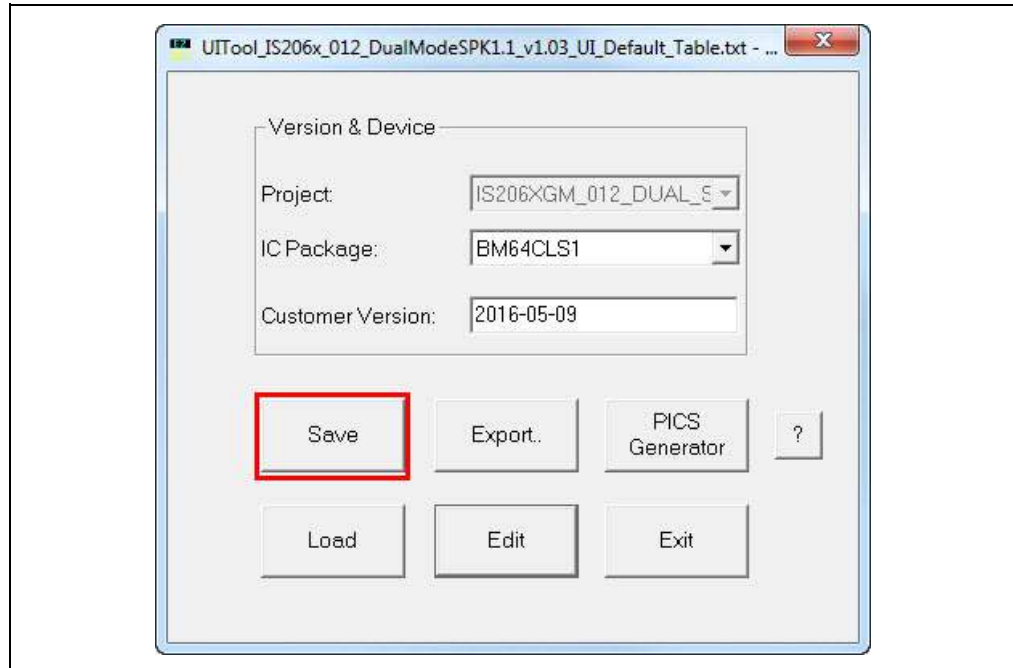
10. After setting up the parameters, click **Finish**. A notification is displayed to check the EEPROM size on the system. Click **OK**, see [Figure 3-14](#).

**FIGURE 3-14: EEPROM NOTIFICATION**



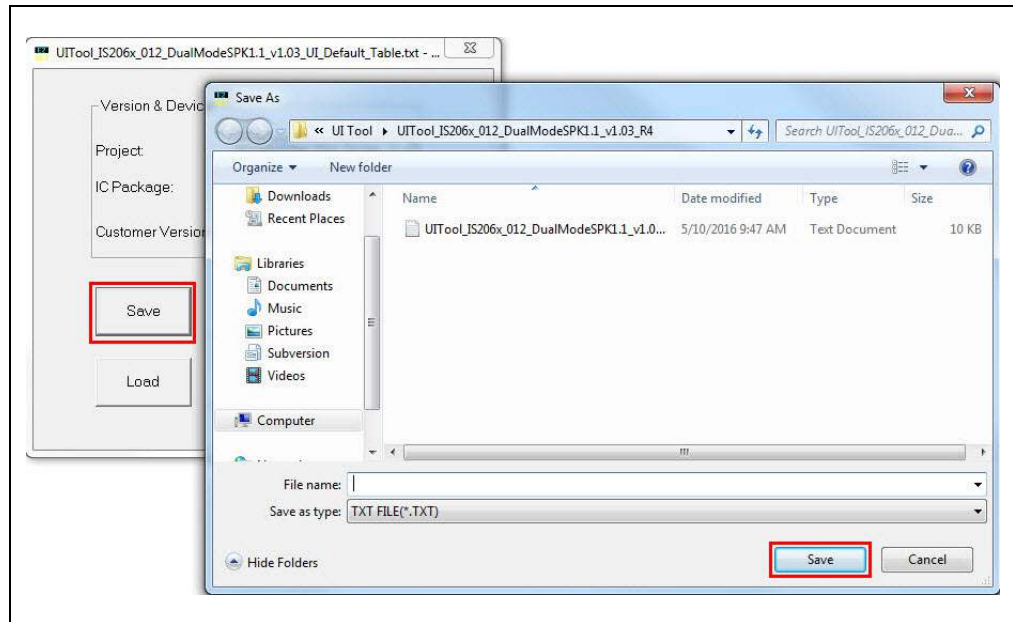
11. Click **Save** to save these UI parameters as a .txt file, see [Figure 3-15](#).

**FIGURE 3-15: SAVING UI PARAMETERS**



12. From the Save As window, select the file location, and then click **Save**, see [Figure 3-16](#).

**FIGURE 3-16: SAVE AS WINDOW**



13. After saving the UI parameters, click **Exit**.

## 3.4.2 DSP Tool Configuration

The DSP configuration tool provides the visual interface to configure the DSP parameters for the voice and the audio signal processing functions. To configure the DSP parameters, perform the following actions:

1. Open the DSP tool and a dialog displays with various options (tabs) to configure the parameters, as illustrated in [Figure 3-17](#).

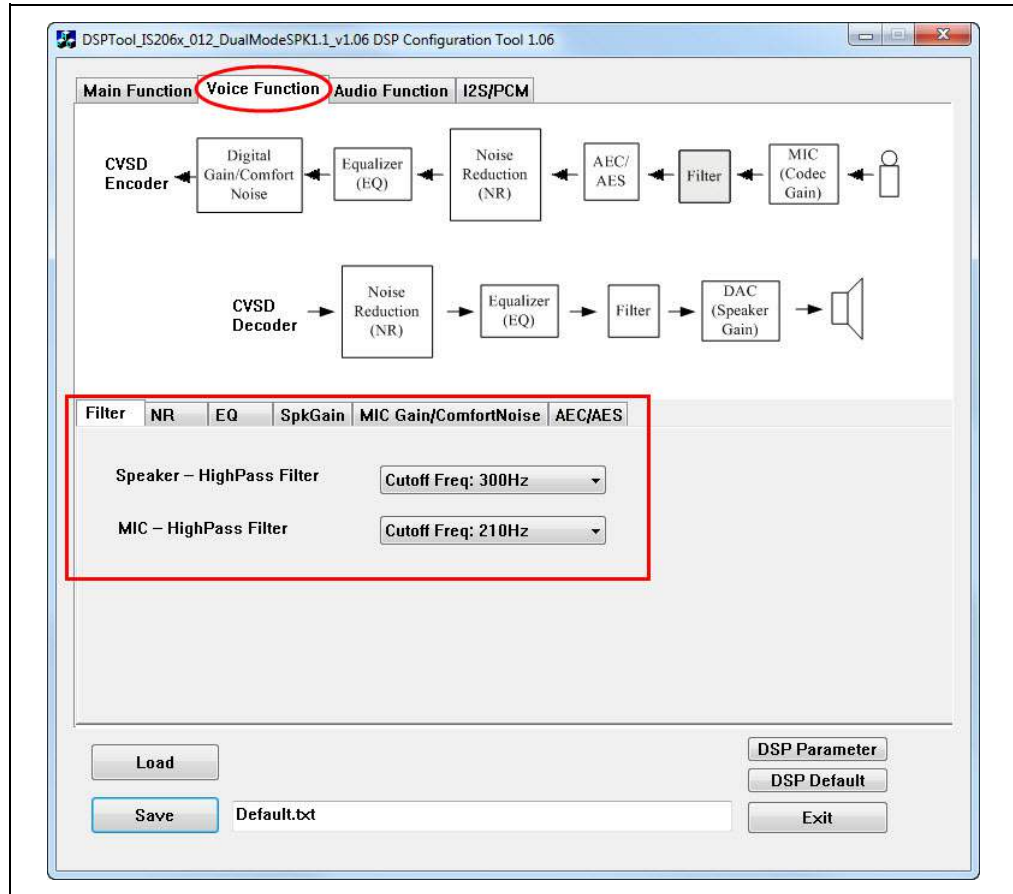
**Note:** Download and install the DSP tool, which is available on the Microchip web site: [www.microchip.com/BM64](http://www.microchip.com/BM64). For this demonstration DSPTool\_IS206x\_012\_DualModeSPK1.1\_v1.06 is used.

**FIGURE 3-17: DSP TOOL SETTINGS**



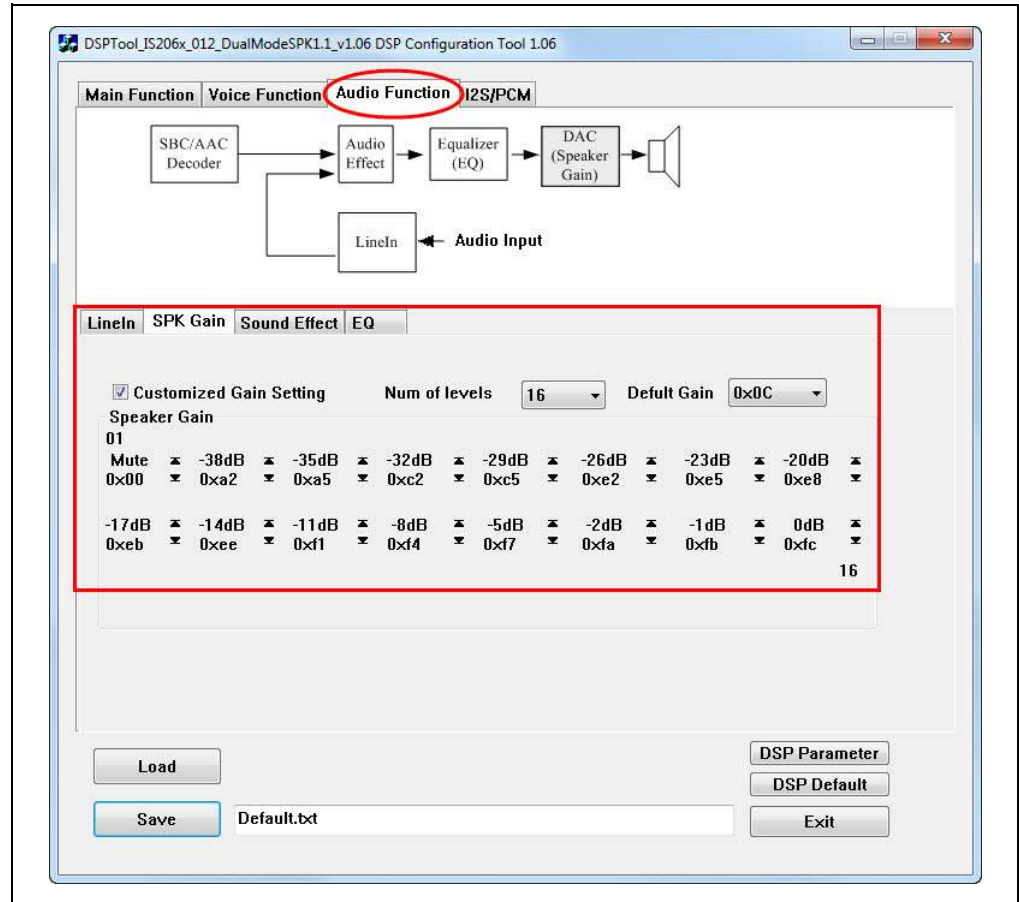
- In the **Voice Function** tab, set the parameters as illustrated in [Figure 3-18](#).

**FIGURE 3-18: DSP VOICE FUNCTION SETTING**



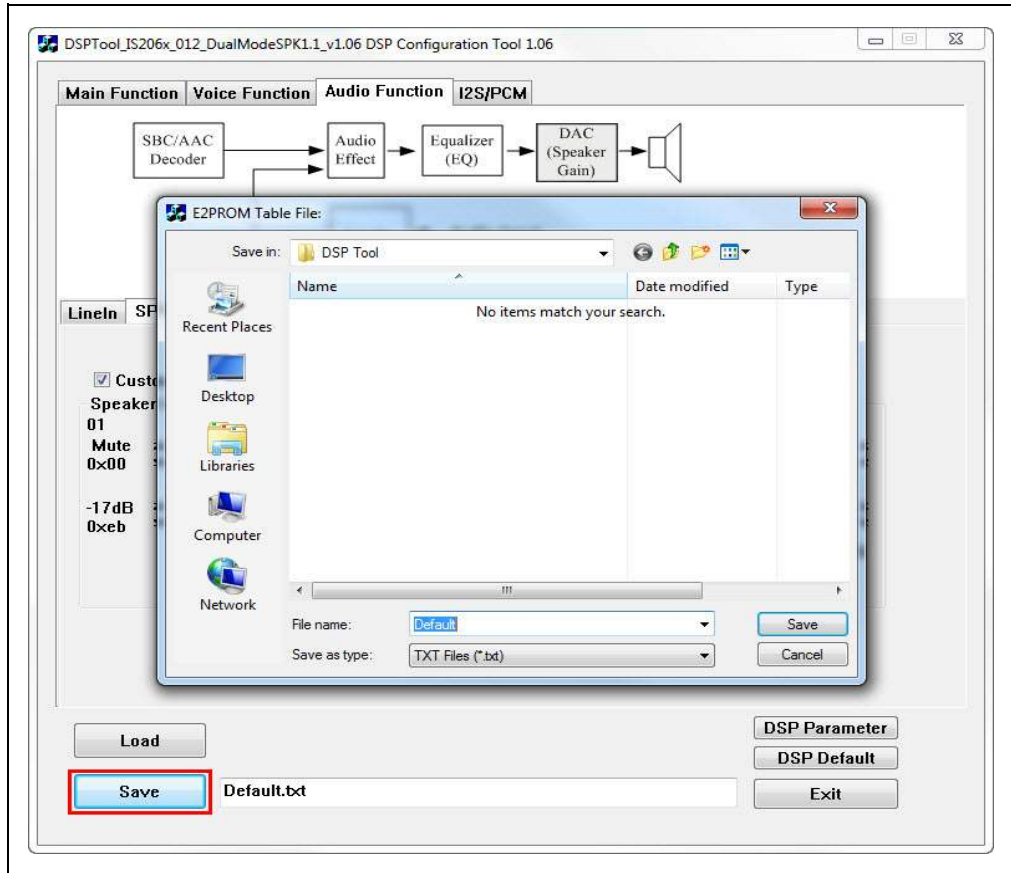
- In the **Audio Function** tab, set the parameters as illustrated in Figure 3-19.

**FIGURE 3-19: DSP AUDIO FUNCTION SETTING**



- Click **Save** to save these DSP parameters as .txt file, see [Figure 3-20](#).

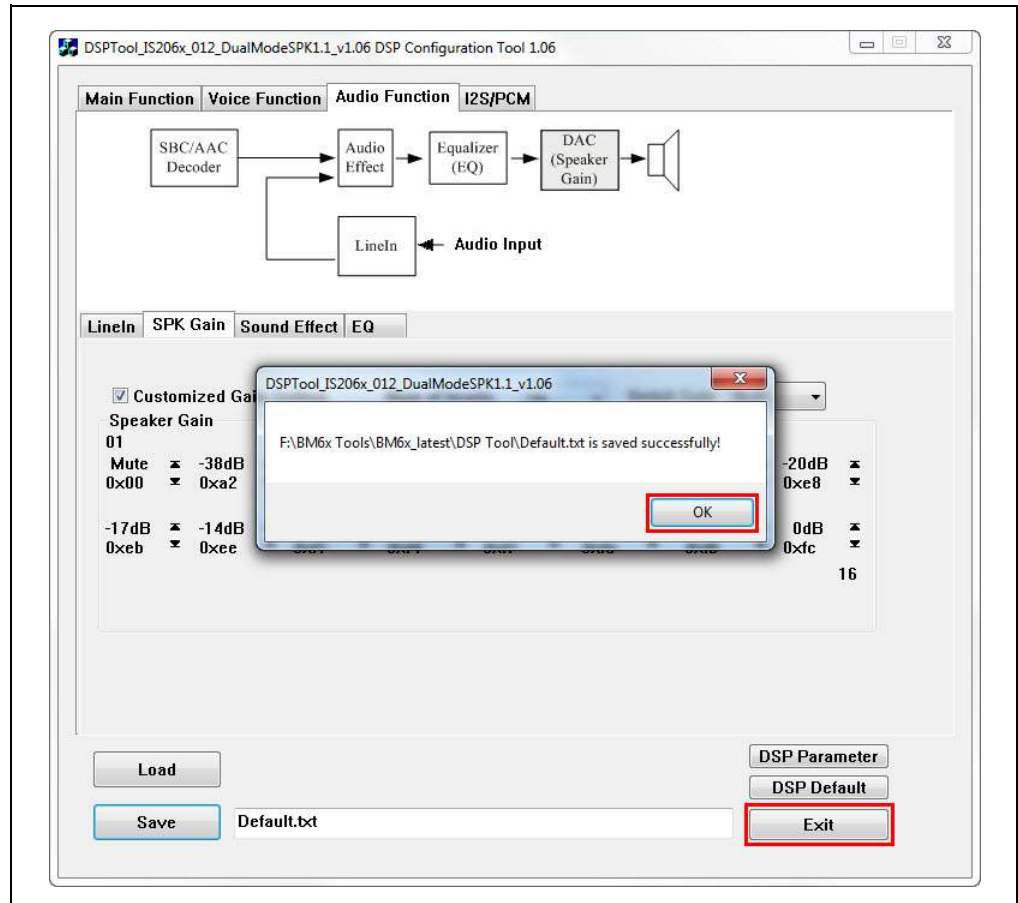
**FIGURE 3-20: SAVING DSP PARAMETERS**





5. After saving the DSP parameters, from the notification pop up, click **OK**, see [Figure 3-21](#). Click **Exit** to exit the DSP tool settings.

**FIGURE 3-21: SAVE NOTIFICATION**



## 3.4.3 MPET Tool Configuration

The MPET tool is used to merge the UI and the DSP parameters, and generate a patch file (.ipf) or binary file (.bin). To generate a patch file using the MPET tool, perform the following actions:

1. Open the MPET tool and then click **Next** to continue with the configuration settings, see [Figure 3-22](#).

**Note:** Download and install the MPET tool, which is available on the Microchip web site: [www.microchip.com/BM64](http://www.microchip.com/BM64). For this demonstration MPET\_V2.1.29.4804 is used.

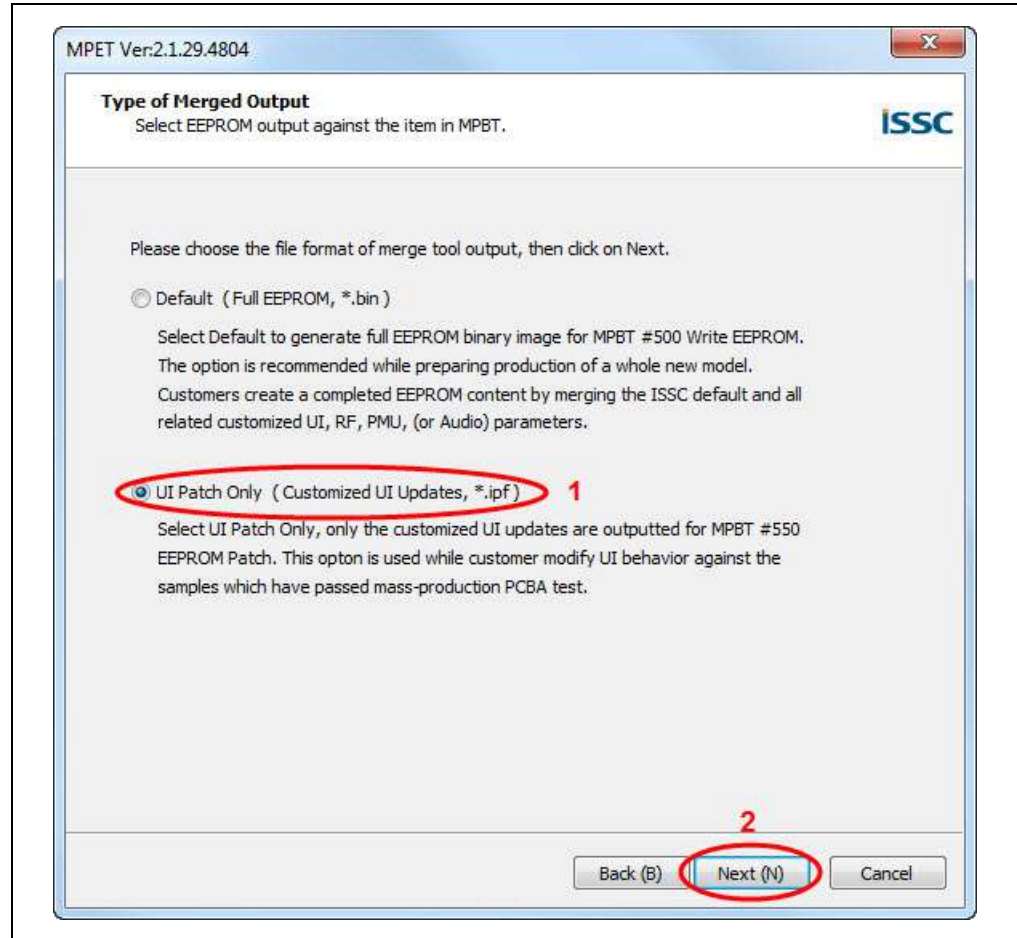
**FIGURE 3-22: MPET TOOL SETTING**



2. Select **UI Patch Only** to merge the UI and the DSP parameters and then click **Next**, see [Figure 3-23](#).

**Note:** For the UI parameter settings, refer to [3.4.1 “UI Tool Configuration”](#) and for the DSP parameter settings, refer to [3.4.2 “DSP Tool Configuration”](#).

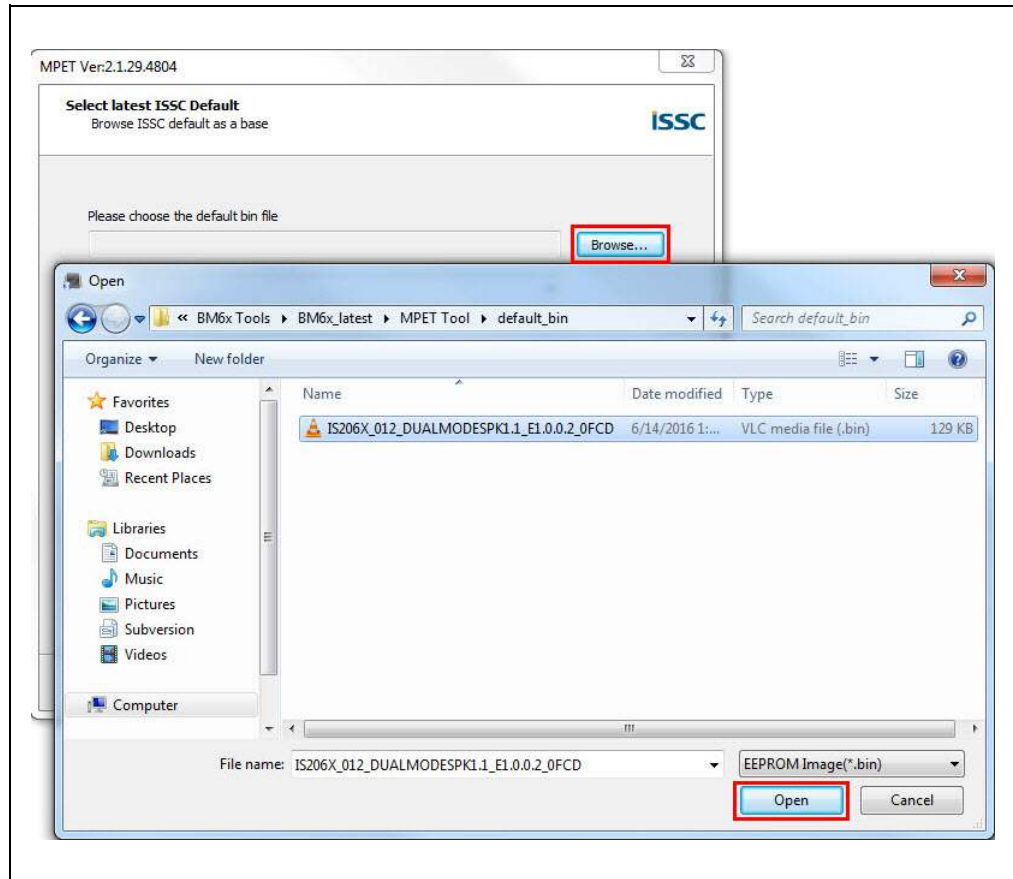
**FIGURE 3-23: MERGE UI AND DSP PARAMETERS**



# BM64 EVB User's Guide

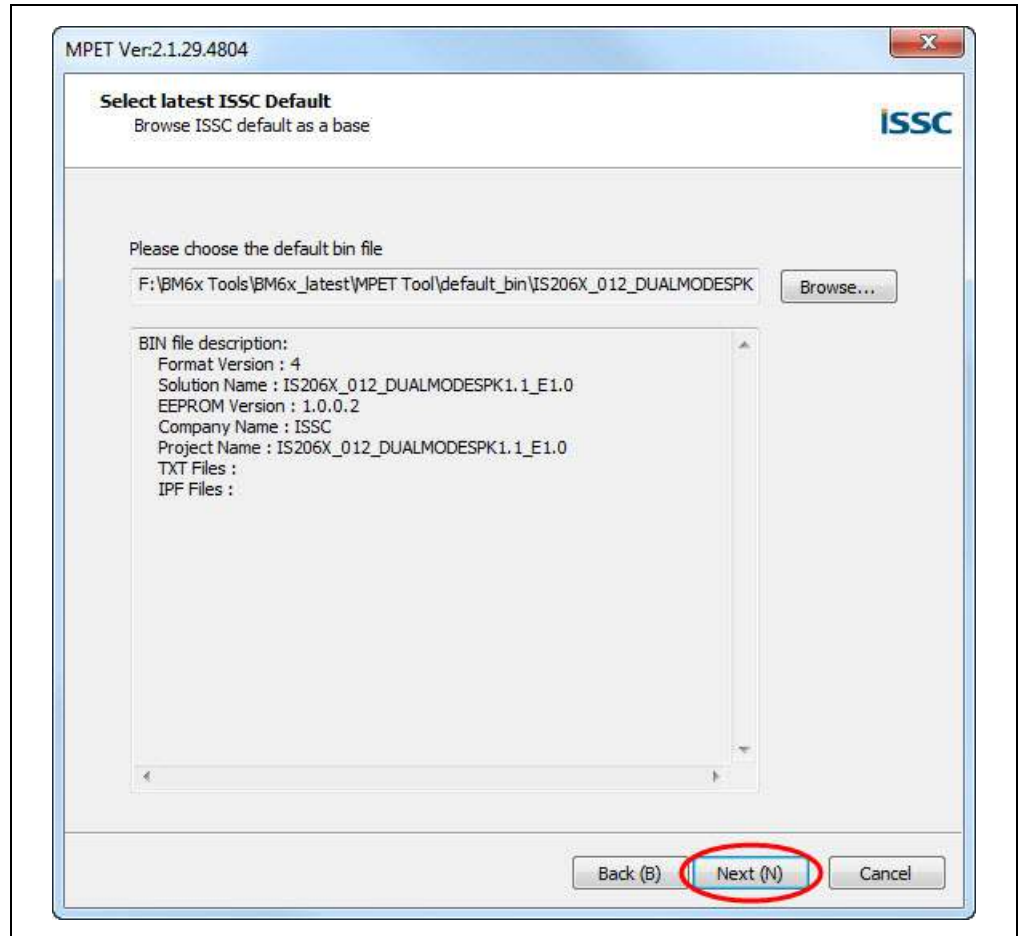
3. Click **Browse** to load the default .bin file (provided with the MPET tool). From the Open window, select the default .bin file and then click **Open**, see [Figure 3-24](#).

**FIGURE 3-24: LOADING DEFAULT BIN FILE**



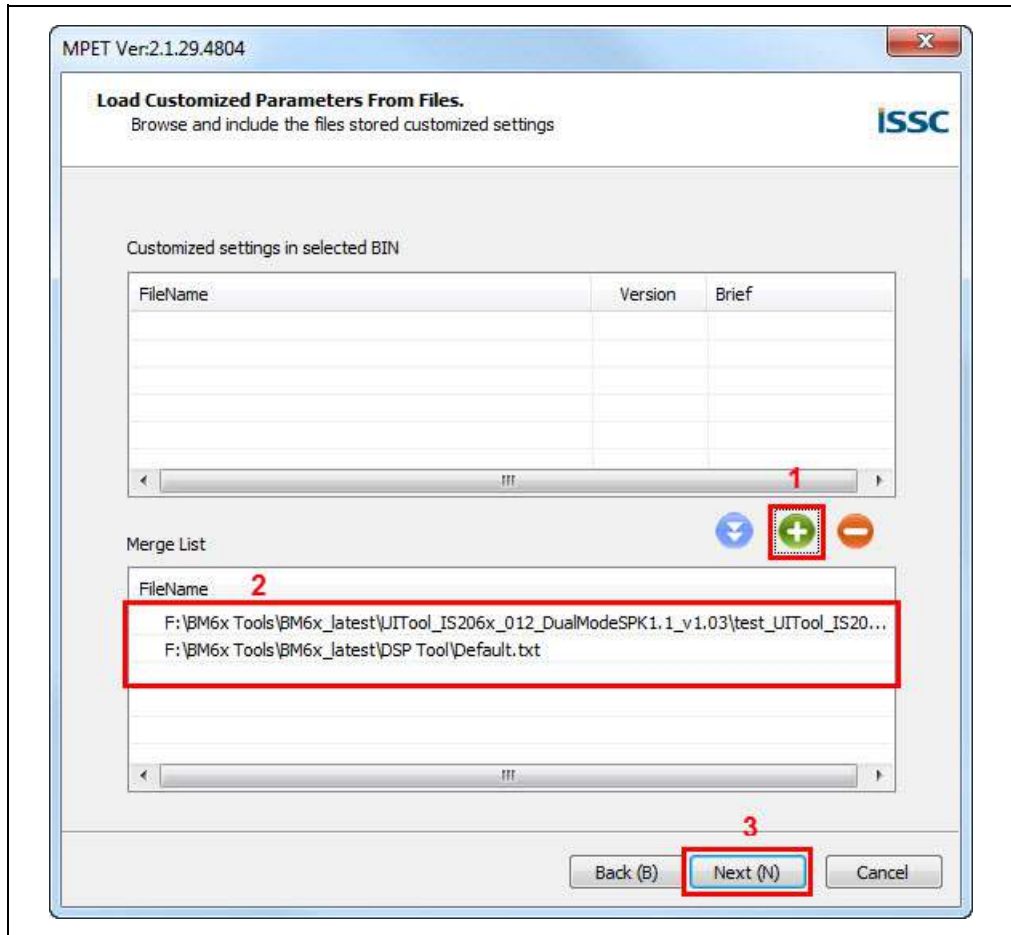
4. The bin file description is displayed. Click **Next**, see [Figure 3-25](#).

**FIGURE 3-25: DEFAULT BIN FILE SETTING**



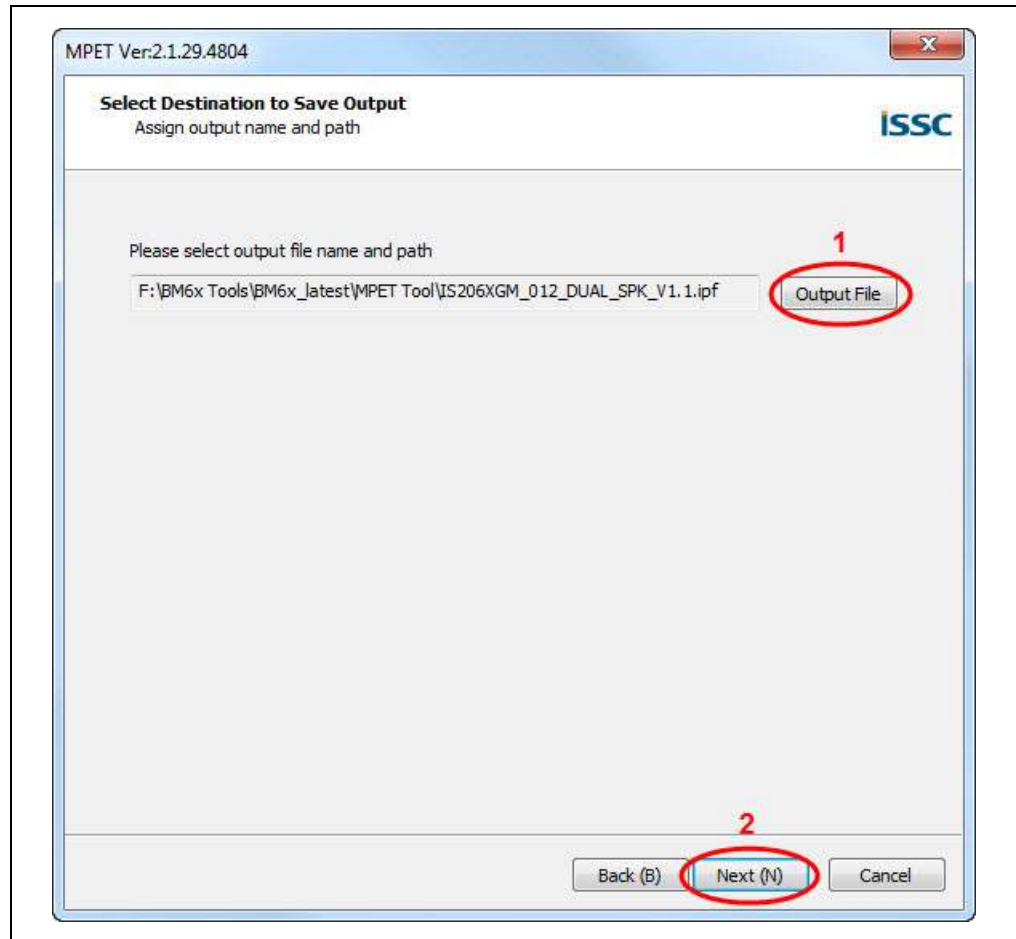
5. Click the “+” button to load the UI and DSP parameters (.txt file) into the MPET tool to merge with the EEPROM table and then click **Next**, as illustrated in Figure 3-26.

**FIGURE 3-26: CUSTOMIZED SETTINGS TO MERGE**



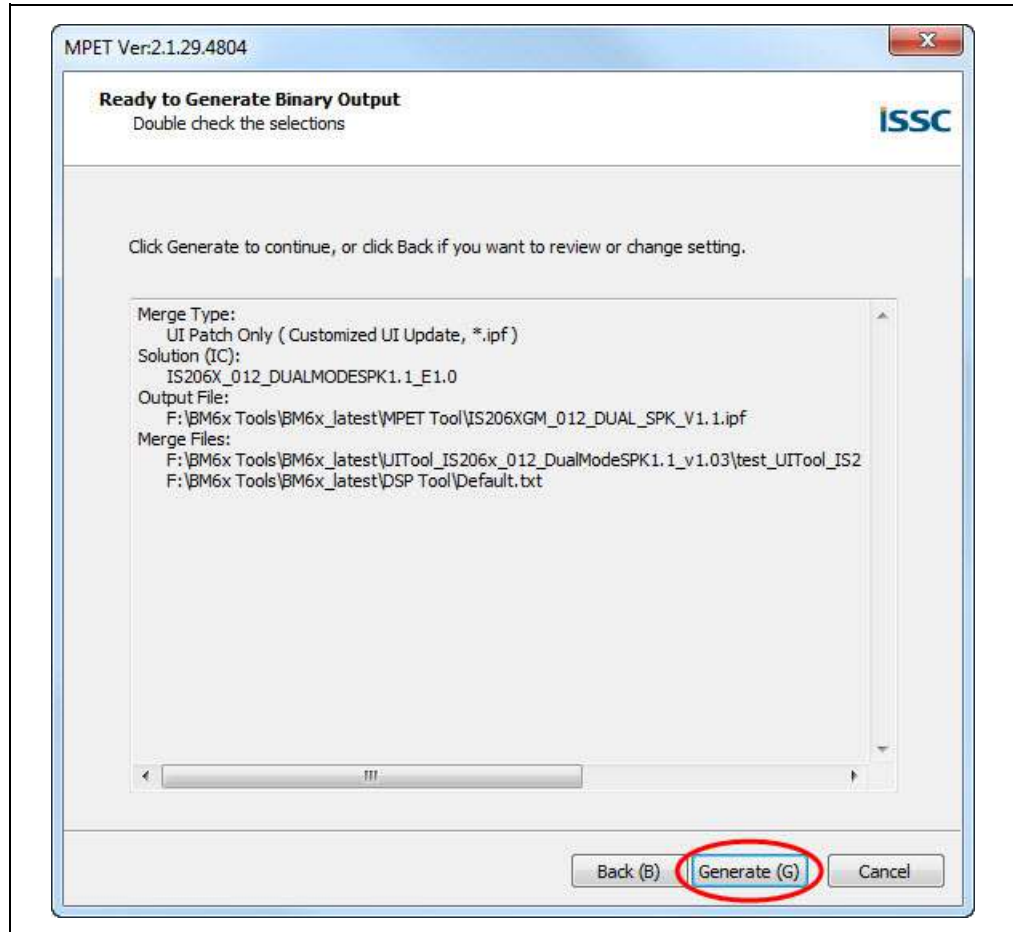
6. Select an Output File path to create the merged EEPROM table (.ipf file) and then click **Next**, see [Figure 3-27](#).

**FIGURE 3-27: SELECTING OUTPUT FILE NAME AND PATH**



7. Click **Generate** to generate the EEPROM table (.ipf file), see [Figure 3-28](#).

**FIGURE 3-28: GENERATE EEPROM TABLE**

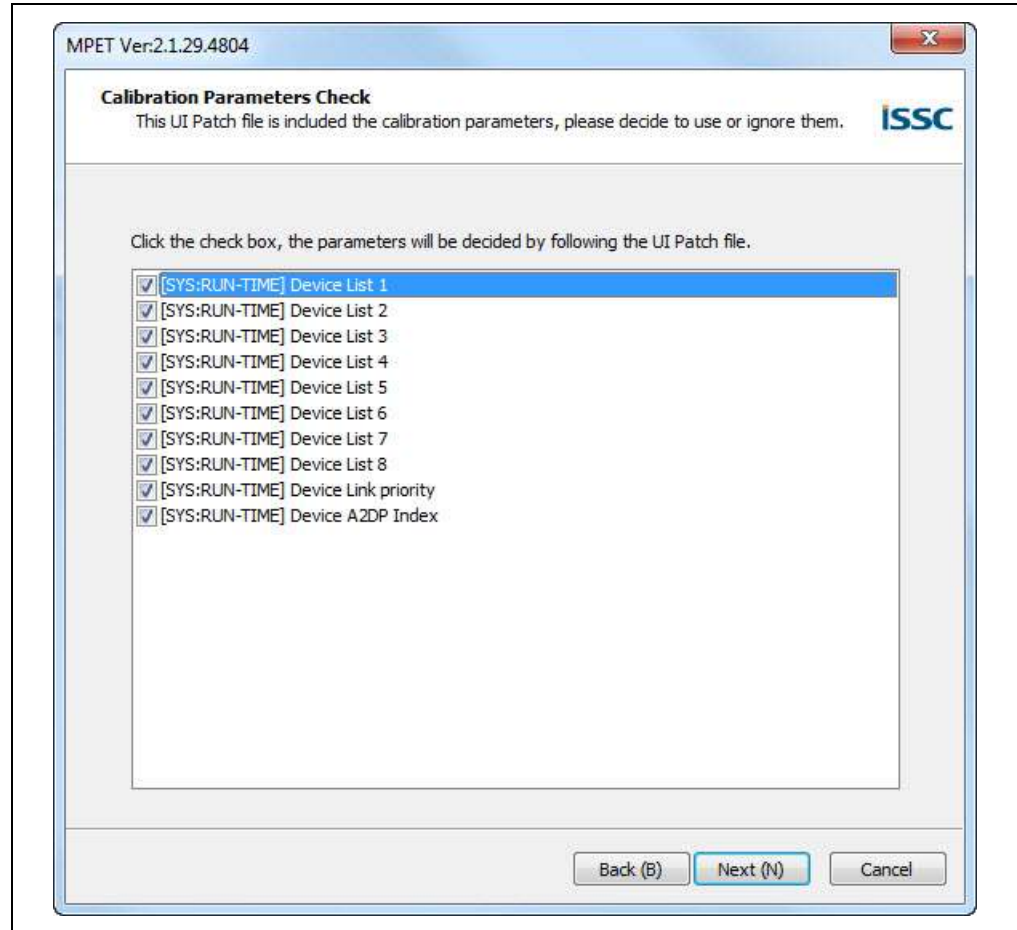




- The calibration parameters included in the UI patch file can be selected or ignored. Click **Next**, see [Figure 3-29](#).

**Note:** If the items are selected, the calibration parameters of the .ipf file will overwrite the parameters in the device.

**FIGURE 3-29: CALIBRATION PARAMETERS CHECK**



9. After generating the merged EEPROM table (.ipf file), click **Finish** to exit the wizard, see [Figure 3-30](#).

**FIGURE 3-30: GENERATED OUTPUT FILE**



## 3.5 UPDATING EEPROM PARAMETERS

The EEPROM tool is used to write the EEPROM parameters in the BM64 module. Perform the following actions to update the EEPROM parameters:

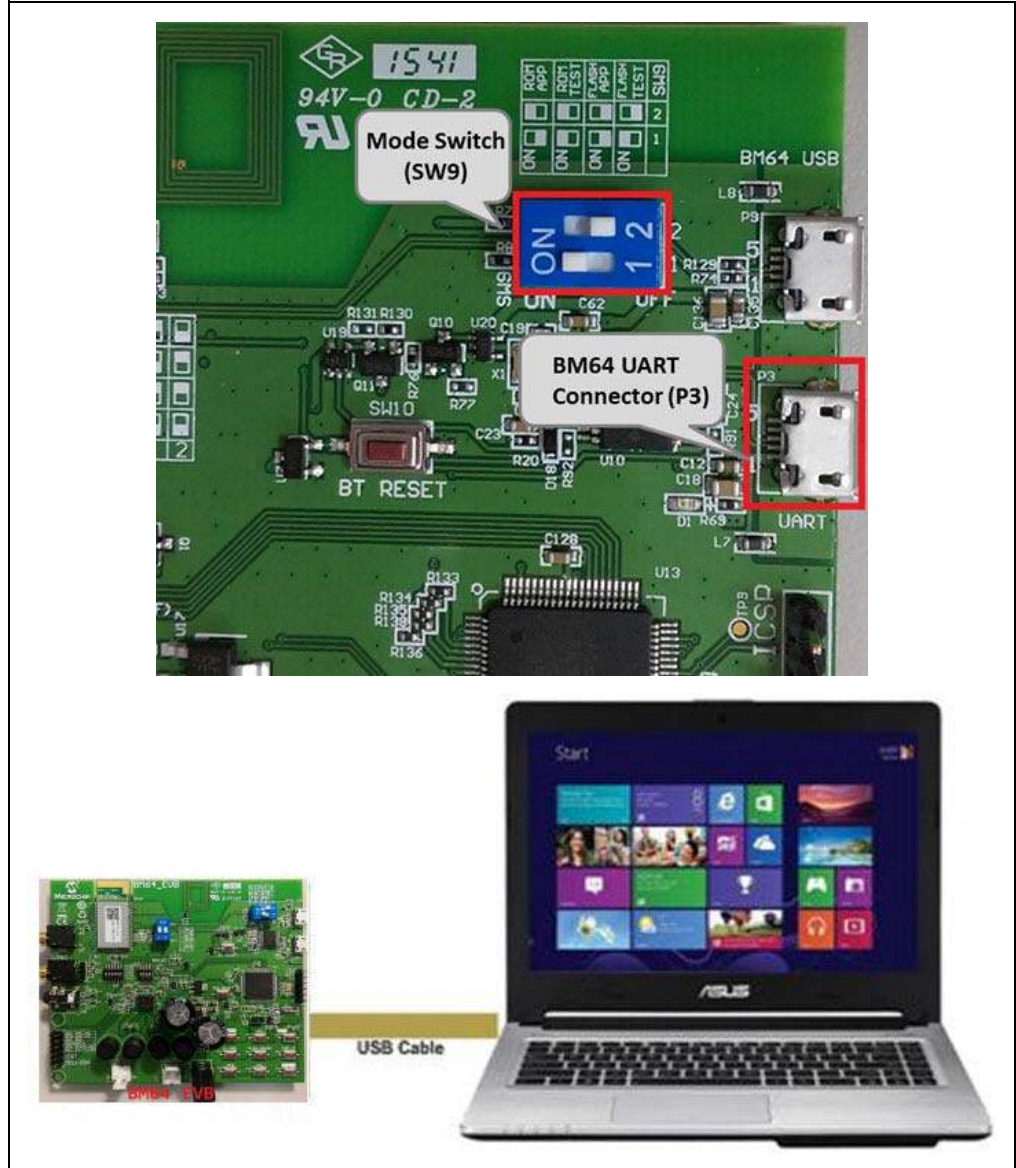
1. Set switch SW9 to Flash Test mode, see [Figure 3-31](#).

**FIGURE 3-31: SWITCH SW9 IN FLASH TEST MODE**



2. Connect the BM64 UART Connector (P3) port to a host PC using a micro-USB cable, as illustrated in [Figure 3-32](#). The default LED behavior in Flash Test mode is: LED1 (blue) and LED2 (red) will be ON.

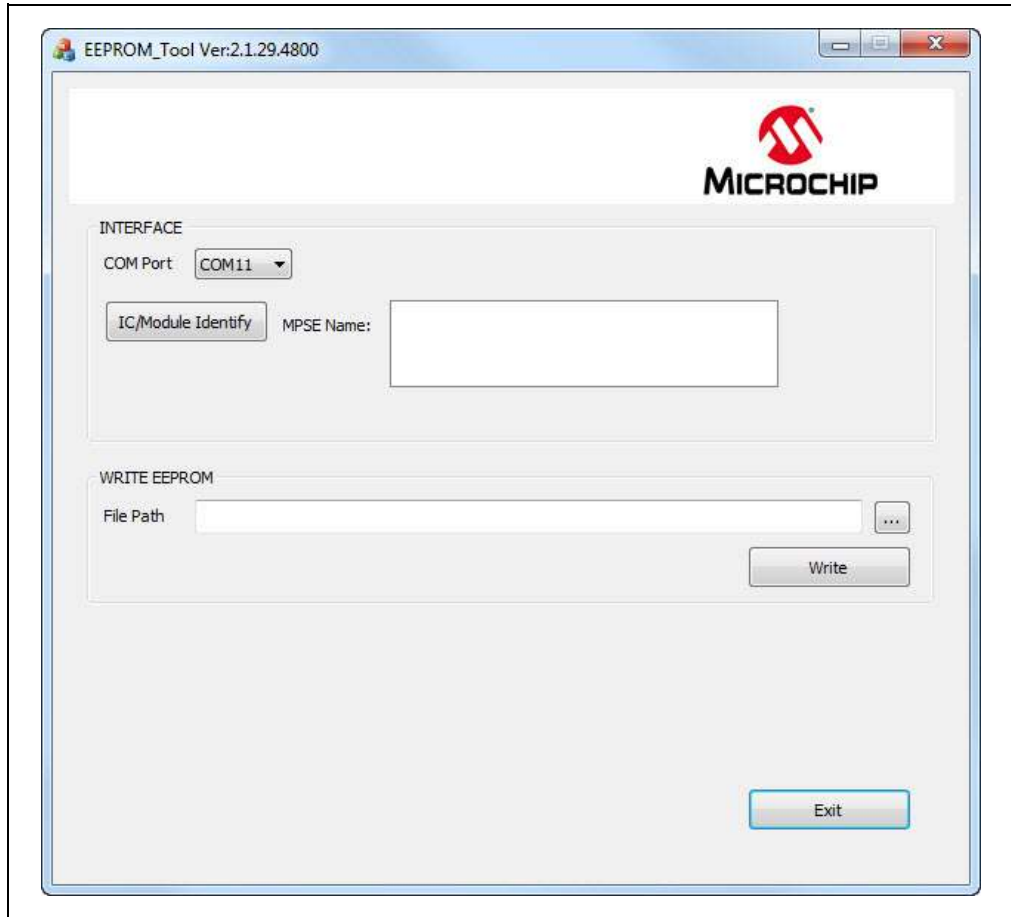
FIGURE 3-32: EEPROM PARAMETERS SETUP



**Note:** Download and install the EEPROM tool, which is available on the Microchip web site: [www.microchip.com/BM64](http://www.microchip.com/BM64). For this demonstration EEPROM\_Tool\_V2.1.29.4800 is used.

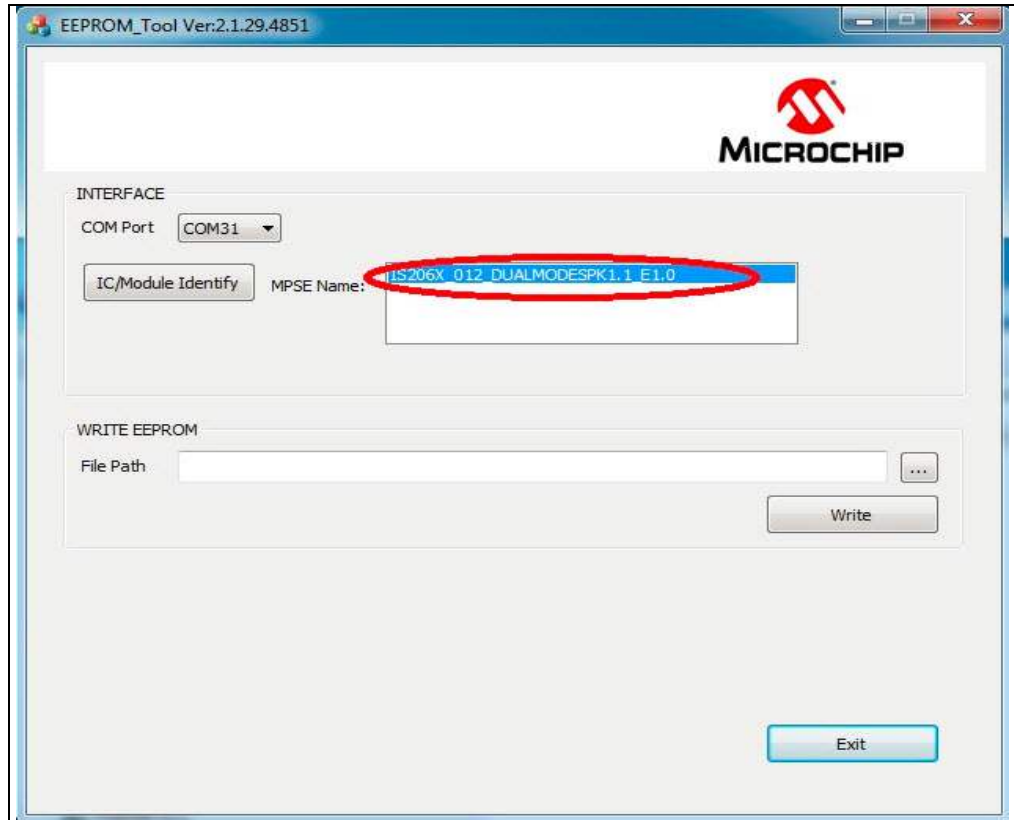
3. Open the EEPROM tool and a window displays, see [Figure 3-33](#).

**FIGURE 3-33: EEPROM TOOL**



- Specify the **COM Port** and click **IC/Module** identity, see [Figure 3-34](#).

**FIGURE 3-34: EEPROM TOOL SETTINGS**

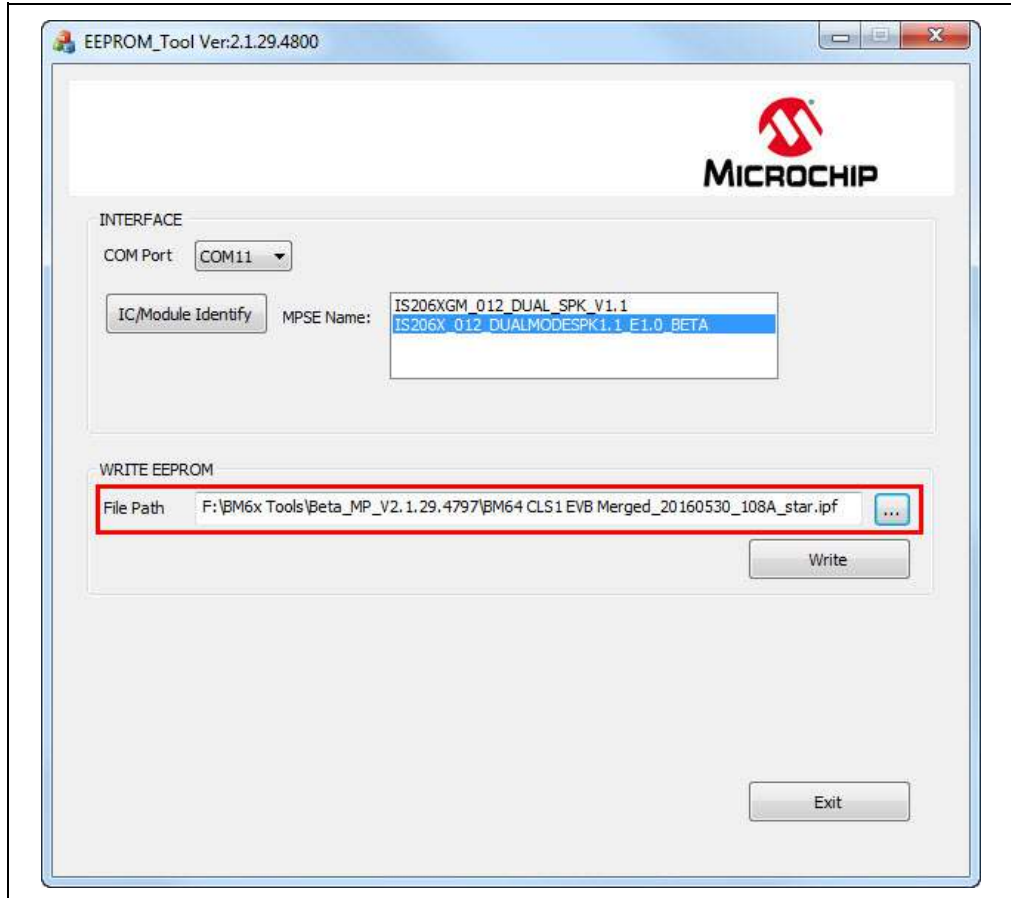


# BM64 EVB User's Guide

5. Click **Browse** and load the generated patch file (.ipf) to write to the EEPROM parameters table on the BM64 module, see [Figure 3-35](#).

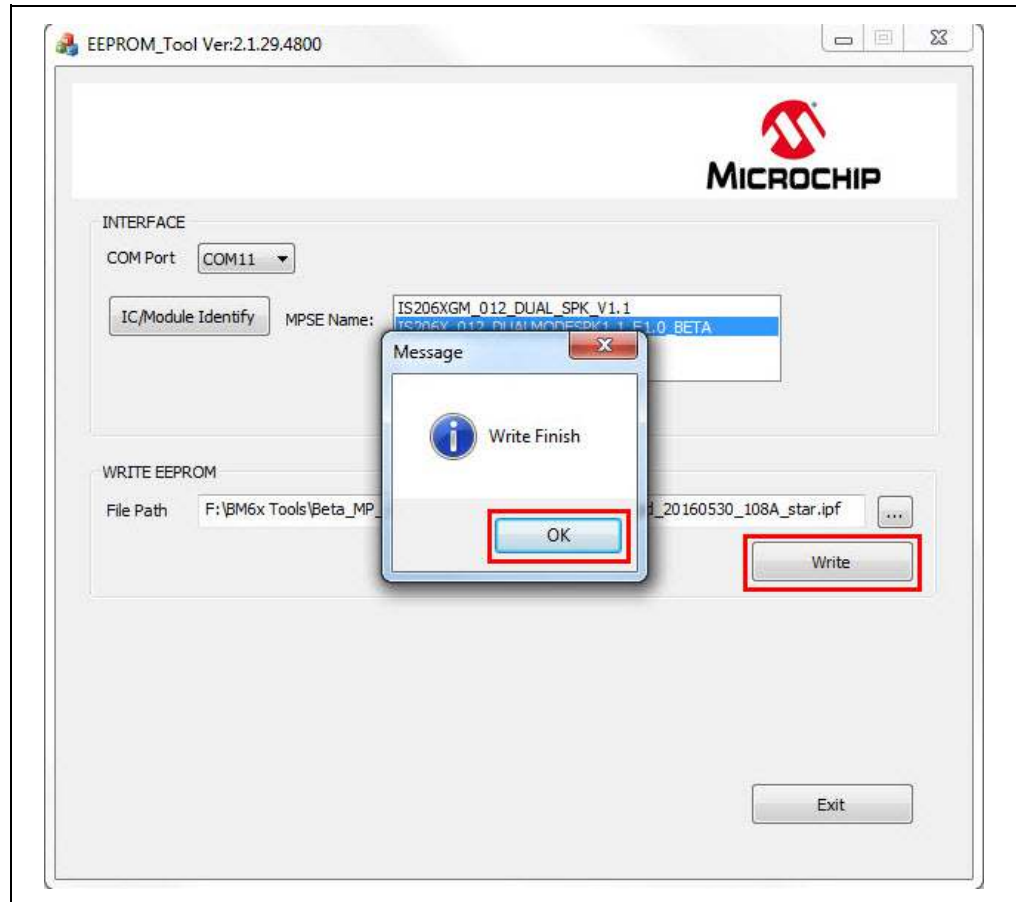
**Note:** The patch file (.ipf) is generated using the MPET tool. For information on generating the patch file, refer to [3.4.3 “MPET Tool Configuration”](#).

**FIGURE 3-35: LOADING GENERATED PATCH FILE**



- Click **Write** to program the EEPROM parameters on the BM64 module. After programming the EEPROM parameters, a message is displayed. Click **OK** as illustrated in [Figure 3-36](#).

**FIGURE 3-36: WRITE EEPROM**



- Click **Exit** and remove the micro-USB cable. Then, set SW9 to Flash Application mode (see [Figure 3-37](#)) and reboot.

**FIGURE 3-37: SWITCH SW9 IN FLASH APPLICATION MODE**



## 3.6 UPDATING FLASH CODE

A new or a specific version of the flash code can be programmed using the Flash Programming tool. To program the Flash code, perform these actions:

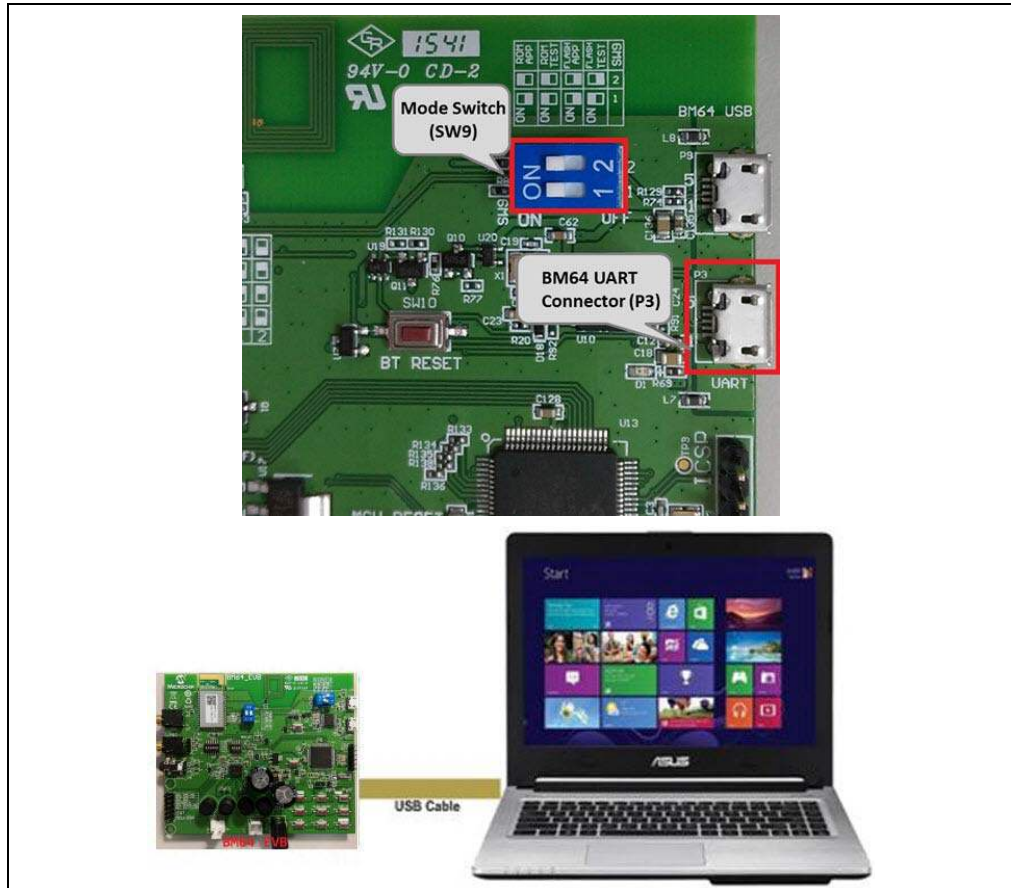
1. Set switch SW9 to ROM Test mode, see [Figure 3-38](#).

**FIGURE 3-38: SWITCH SW9 IN ROM TEST MODE**



2. Connect the BM64 UART connector (P3) port to a host PC using a micro-USB cable, as illustrated in [Figure 3-39](#). The default LED behavior in ROM Test mode is: LED1 (blue) and LED2 (red) will be ON.

**FIGURE 3-39: FLASH CODE SETUP**

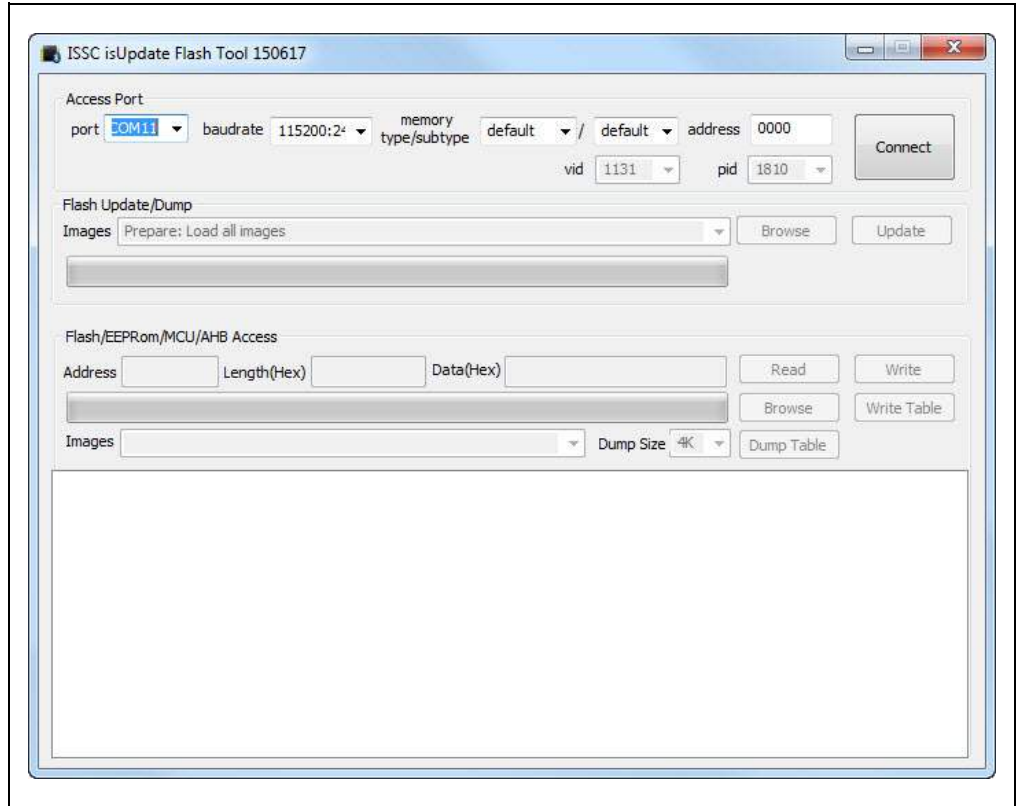


**Note:** Download and install the `isupdate.exe` firmware update tool, which is available on the Microchip web site: [www.microchip.com/BM64](http://www.microchip.com/BM64). For this demonstration, flash code `DUAL_SPK_FIRMWARE_V1.1` is used.



3. Open the `isupdate.exe` firmware update tool on a host PC and a window is displayed, see [Figure 3-40](#).

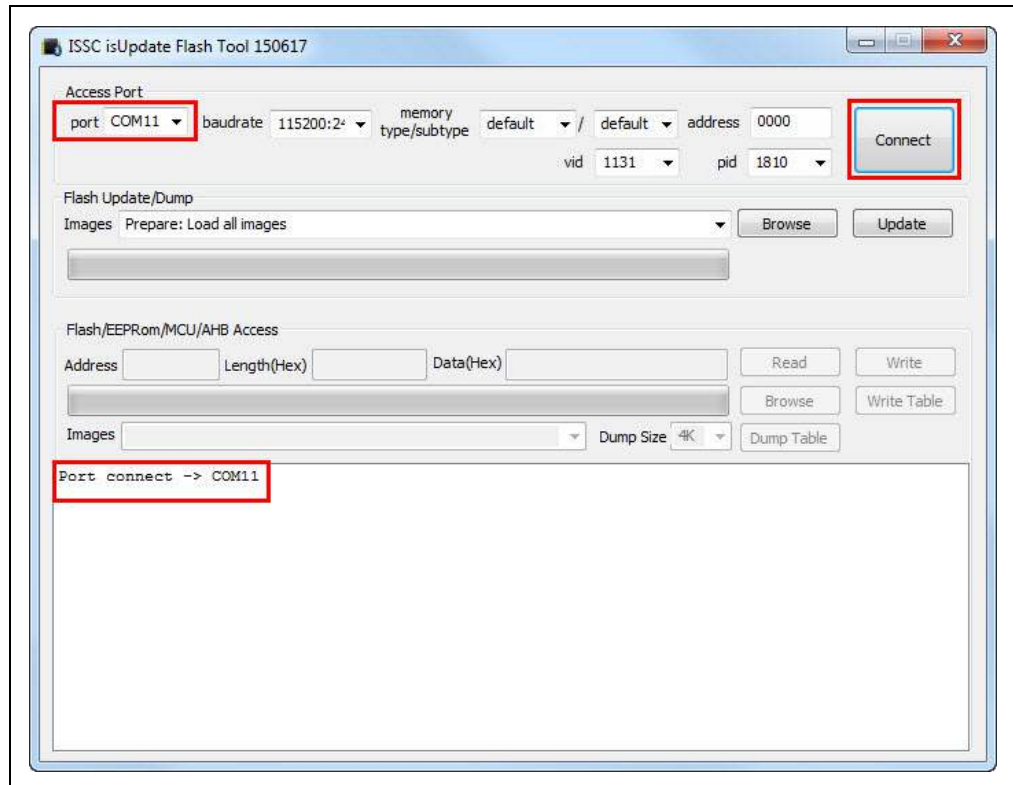
**FIGURE 3-40: FIRMWARE UPDATE TOOL**



# BM64 EVB User's Guide

- Specify the **COM Port** and set the following parameters, as illustrated in [Figure 3-41](#).
  - Baud Rate: 115200
  - Memory type/subtype: default
  - Address: 0000
- Click **Connect**. On successful connection the “Port connect” message is displayed, see [Figure 3-41](#). In case of a failed connection, verify the parameters entered and try connecting again.

**FIGURE 3-41: SETTING THE PARAMETERS**



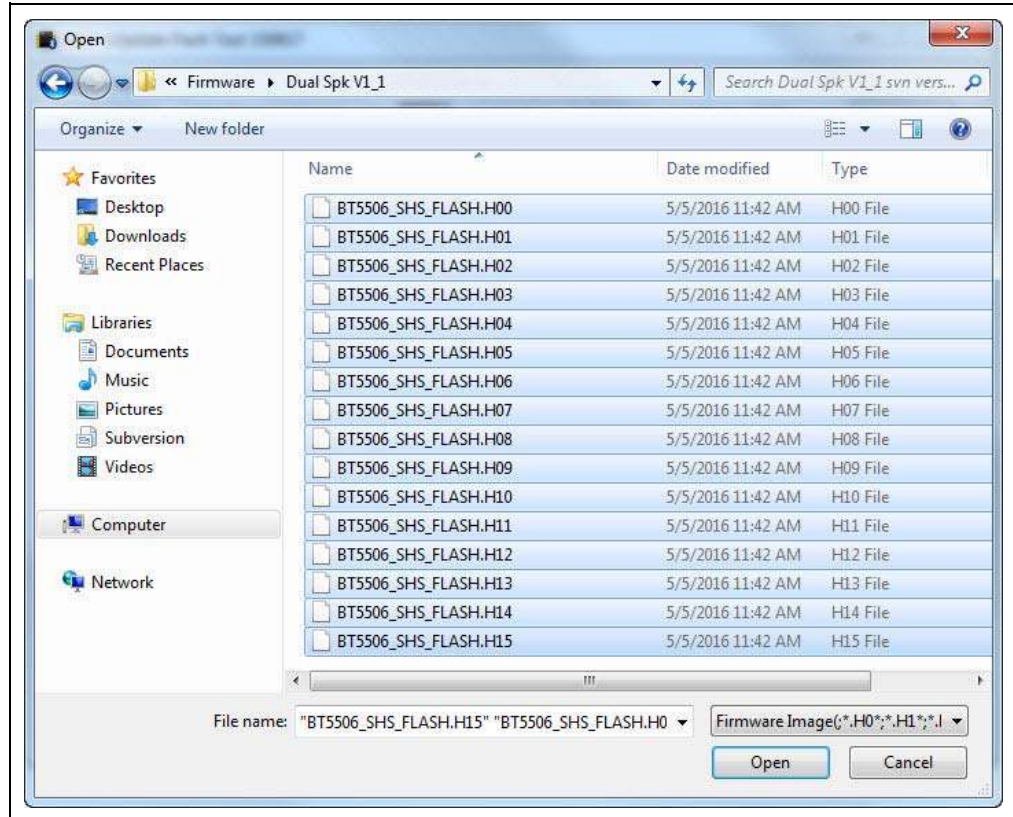
- Click **Browse** to select the Flash code files (.hex) downloaded from the Microchip web site, see [Figure 3-42](#).

**FIGURE 3-42: LOADING FIRMWARE IMAGE**



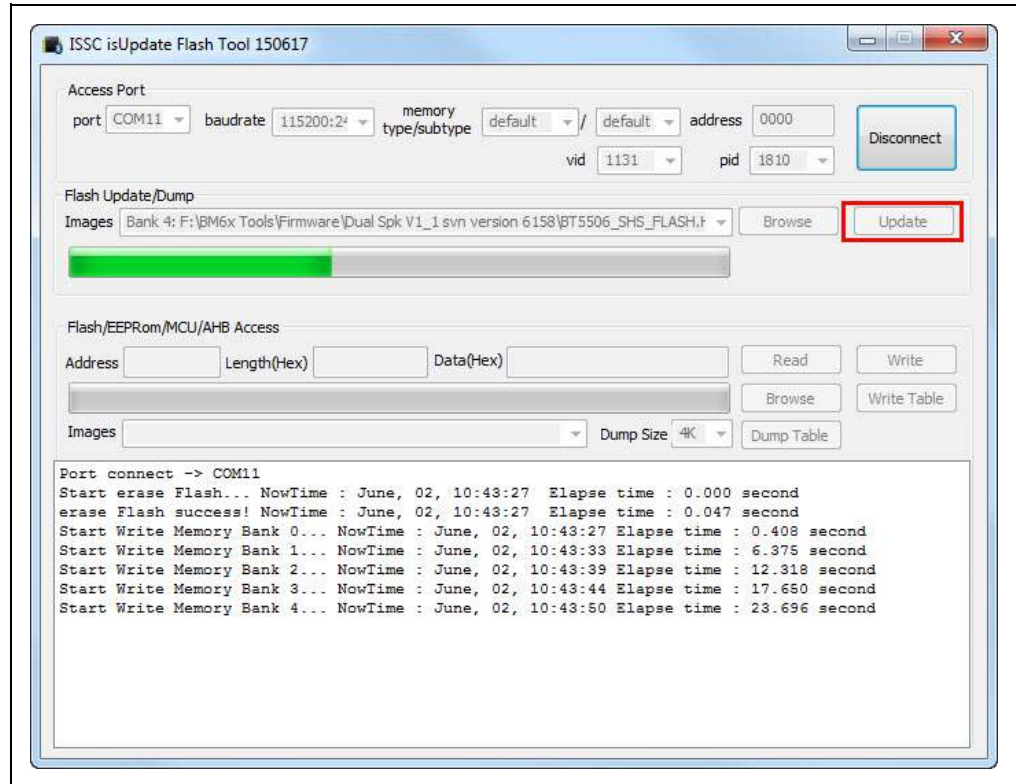
- From the Open window, select the Flash code files and click **Open**, see [Figure 3-43](#).

**FIGURE 3-43: SELECTING FLASH CODE FILES**



- Click **Update** to write the Flash code on the BM64 module, see [Figure 3-44](#).

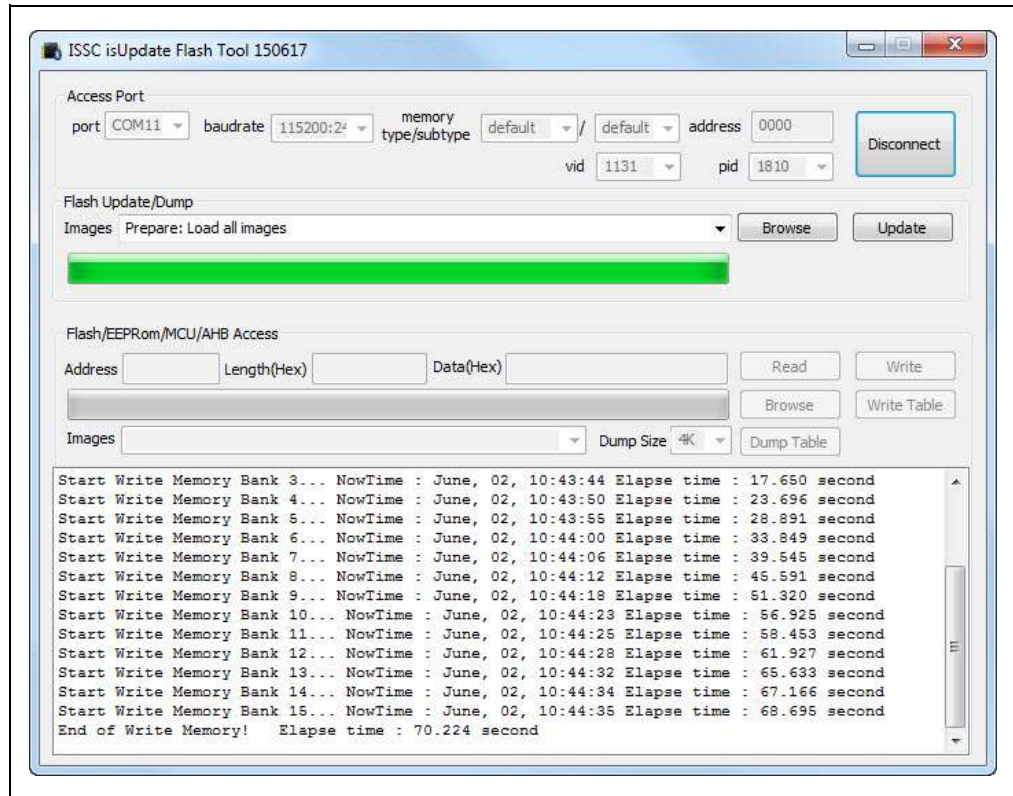
**FIGURE 3-44: FIRMWARE UPDATE**



# BM64 EVB User's Guide

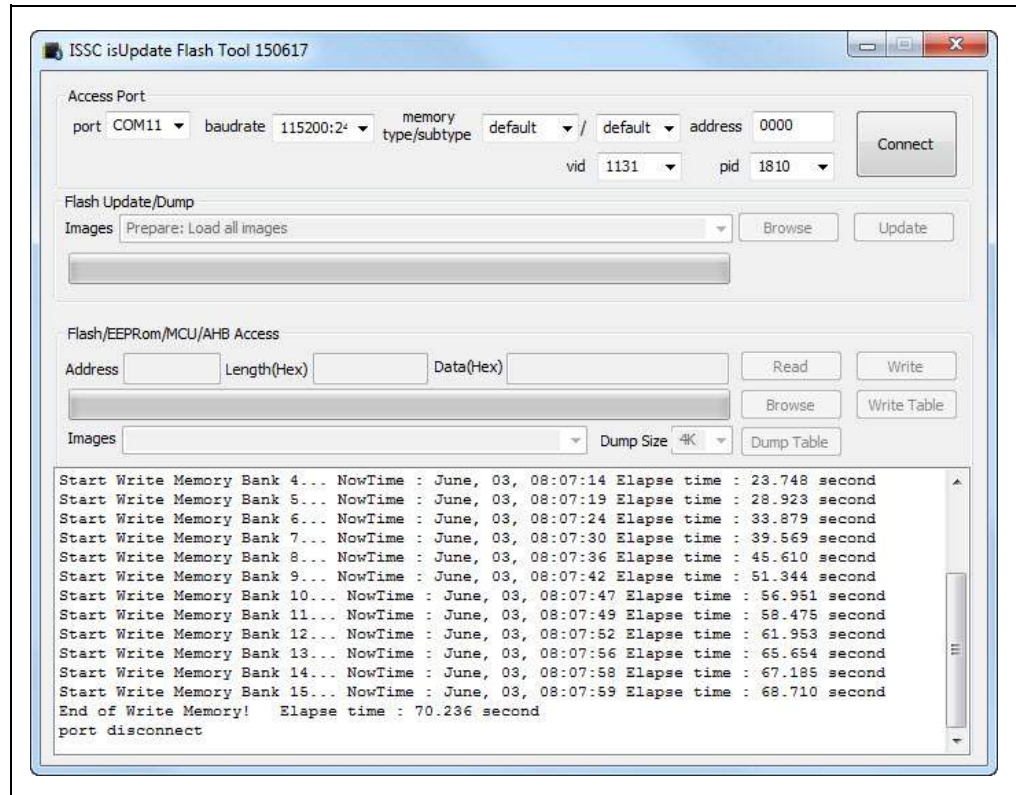
- The Firmware Update tool will start writing the Flash codes. Wait until the message "End of Write Memory!" with the elapse time is displayed, see [Figure 3-45](#).

**FIGURE 3-45: WRITING FLASH CODE**



10. After the Flash code update, click **Disconnect**, see [Figure 3-45](#). The “port disconnect” message is displayed, see [Figure 3-46](#). Then remove the USB cable to reboot.

**FIGURE 3-46: FIRMWARE UPDATE FINISH**



## 3.7 UPDATING MCU PARAMETERS

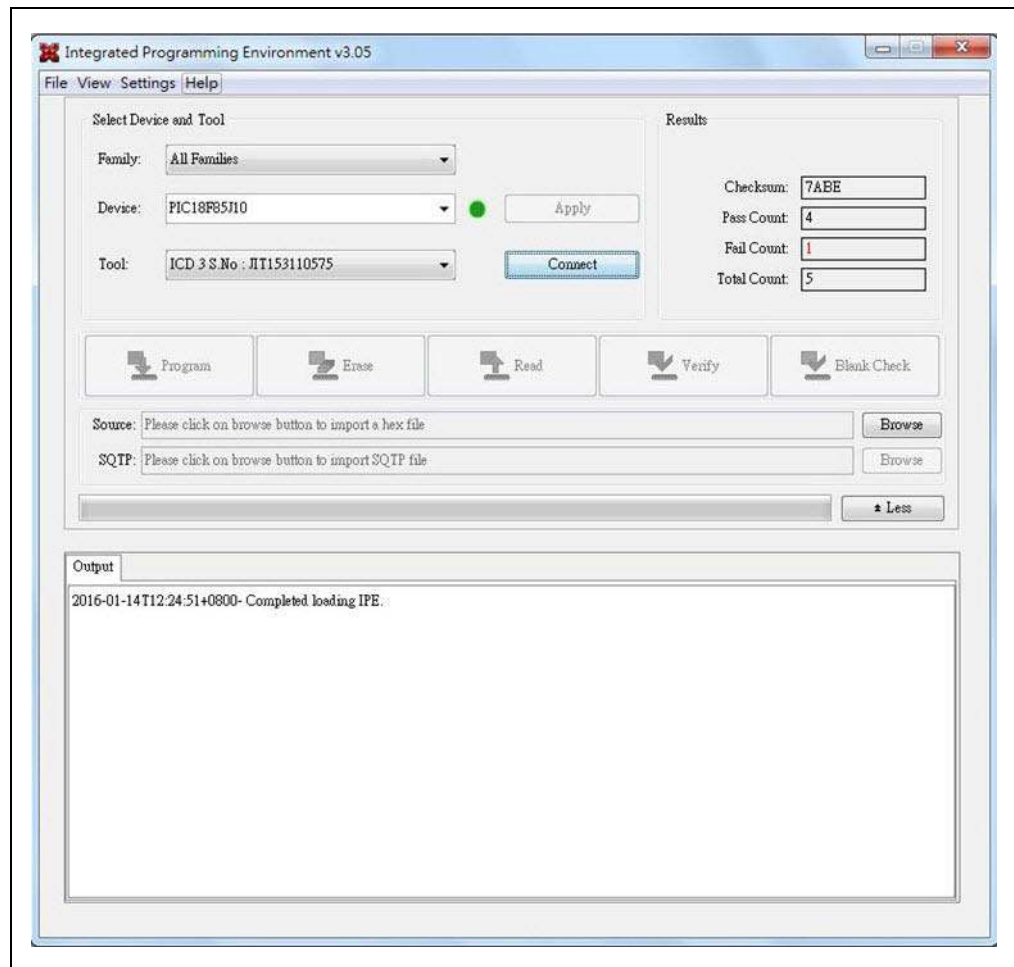
The on-board MCU is preprogrammed for dual-mode, and the MCU code needs to be changed for other applications. To update the MCU parameters, perform the following actions:

1. Plug the 15V DC power adapter into the P2 jack for supplying power to MCU.
2. Connect the MPLAB REAL ICE/MPLAB ICD 3/PICkit™ 3 to ICSP header J5 and then connect MPLAB ICD 3 to a host PC using the USB cable.
3. Ensure that a jumper on JP33 is connected.

**Note:** Download and install the MPLAB X IDE tool, which is available on the Microchip web site: [www.microchip.com/mplab/mplab-x-ide](http://www.microchip.com/mplab/mplab-x-ide).

4. Open the MPLAB X IDE tool and a window displays, see [Figure 3-47](#).

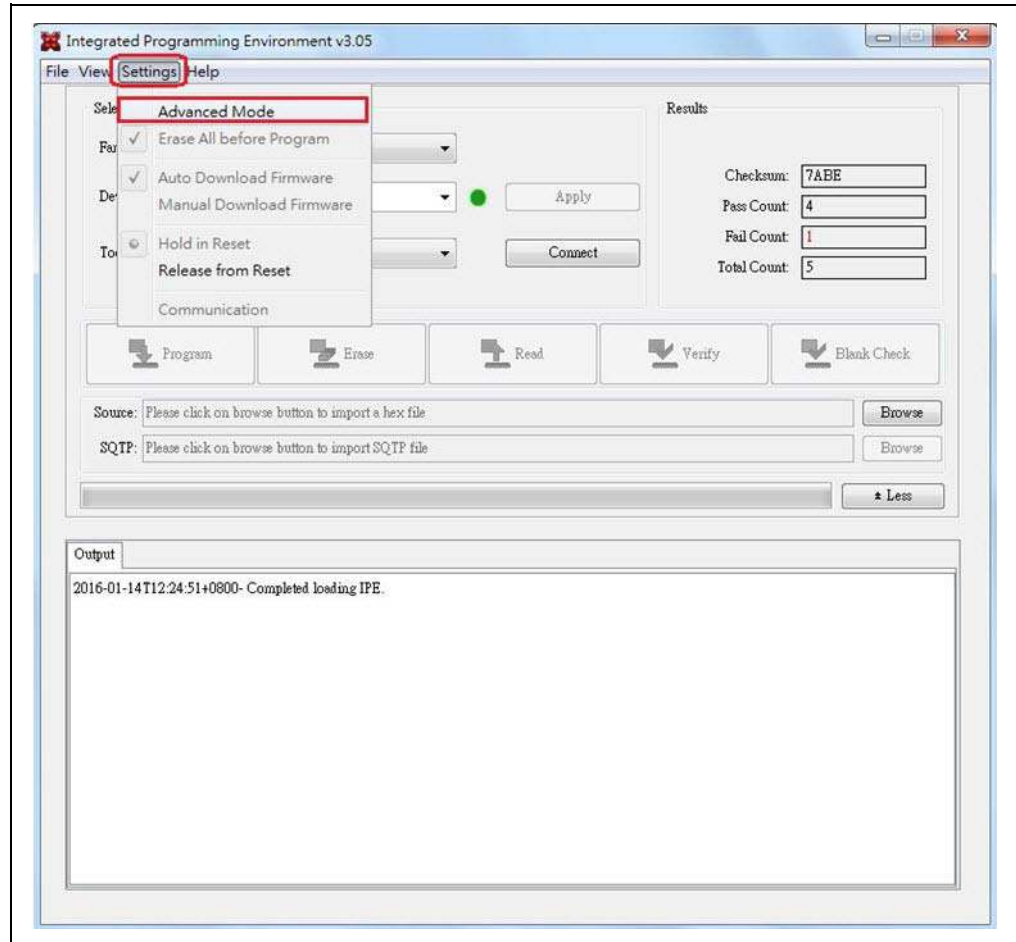
**FIGURE 3-47: MPLAB® X IDE TOOL**





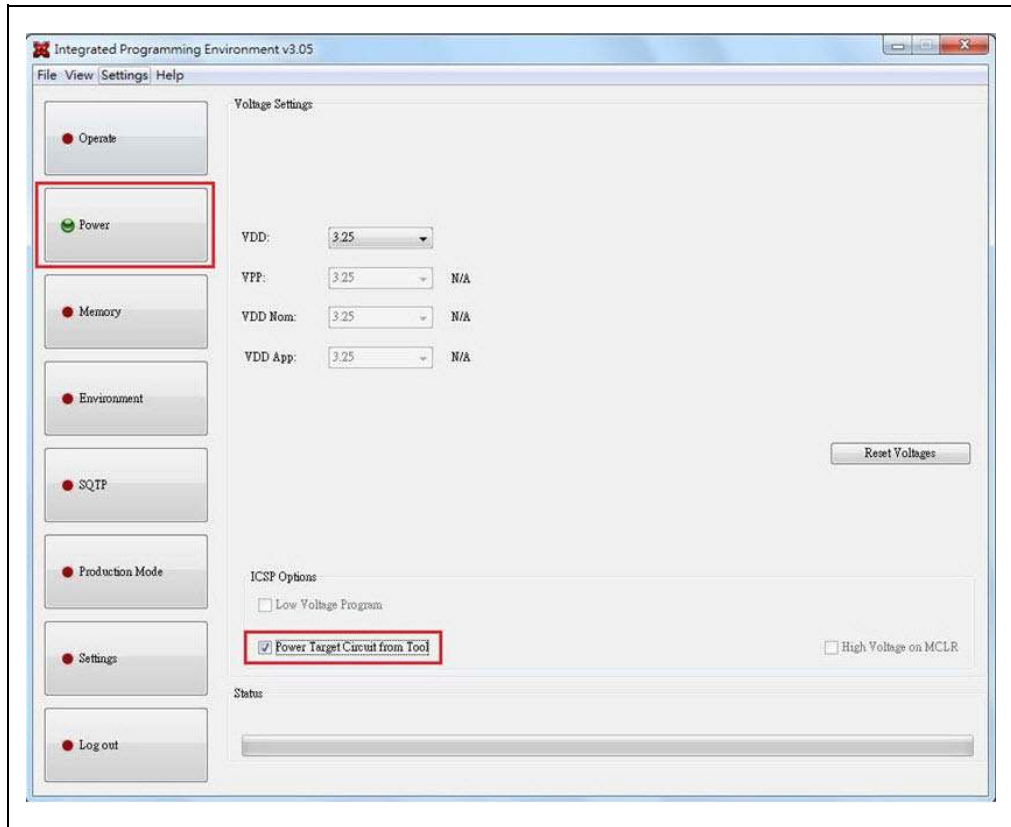
- From Settings, select “Advanced Mode”, see [Figure 3-48](#).

**FIGURE 3-48: ADVANCED MODE SETTINGS**



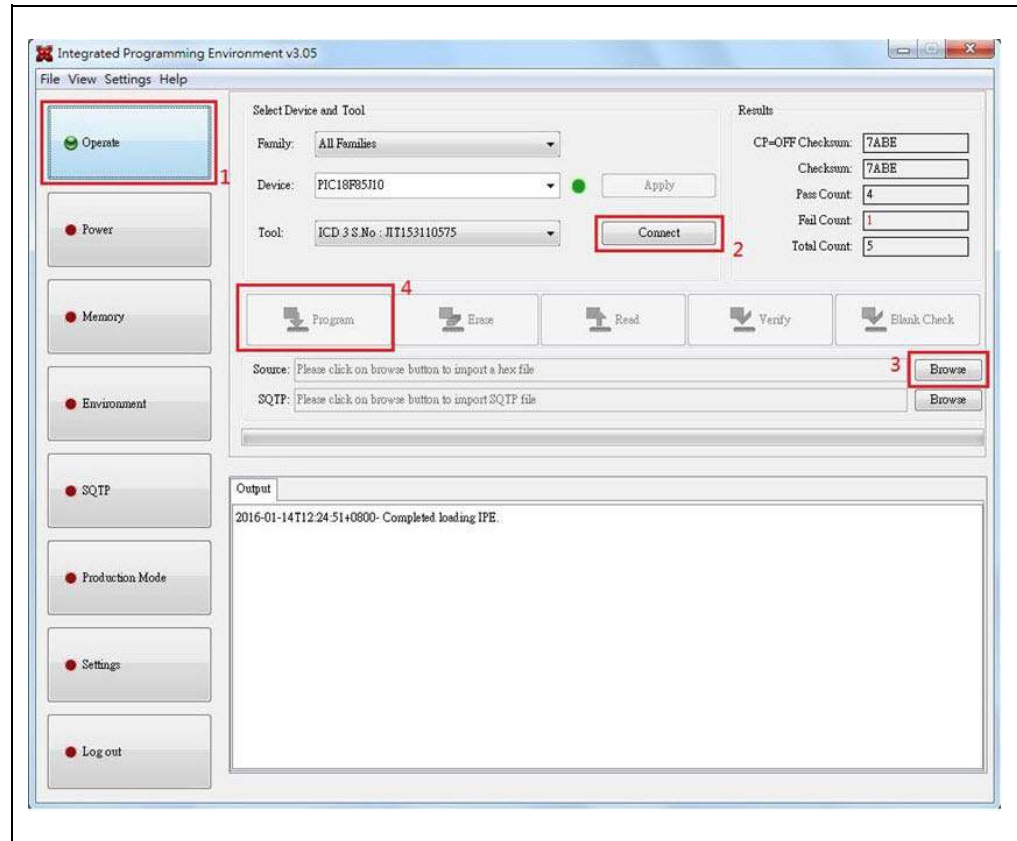
- The MPLAB X IDE tool will display a window with various options (tabs) to configure the parameters. Click the **Power** tab, and then enable **Power Target Current from Tool**, as illustrated in [Figure 3-49](#).

**FIGURE 3-49: POWER TARGET CURRENT FROM TOOL**



7. Select the **Operate** tab, click **Connect** to connect with the MPLAB ICD 3, as illustrated in Figure 3-50. Click **Browse** to load the dual-mode PIC18 code, and then click **Program** to program it.

**FIGURE 3-50: PROGRAMMING MCU CODE**



# BM64 EVB User's Guide

---

NOTES:

**Appendix A. Schematics**

**A.1 REFERENCE SCHEMATICS**

**FIGURE A-1: BM64 EVB SCHEMATICS**

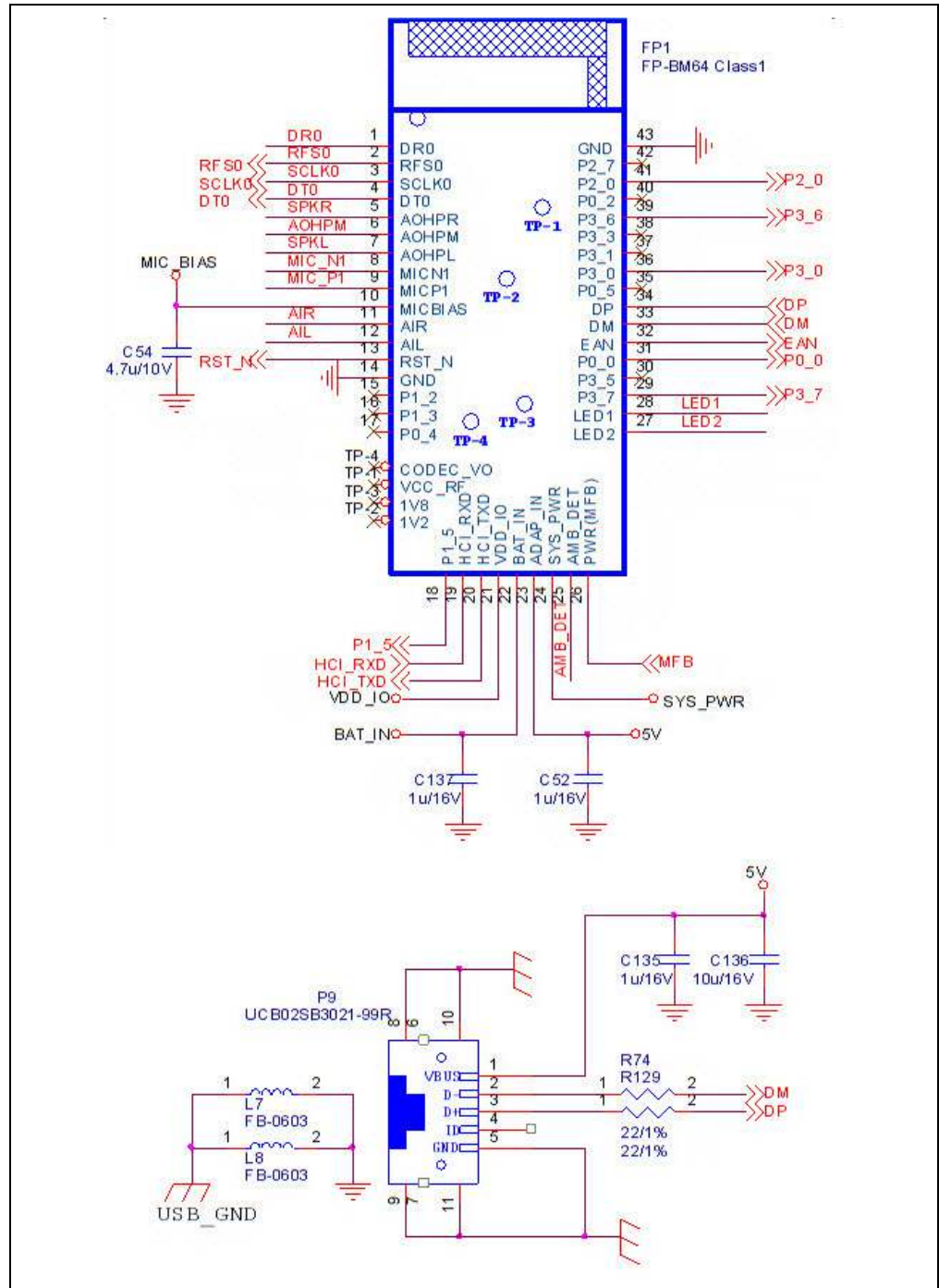
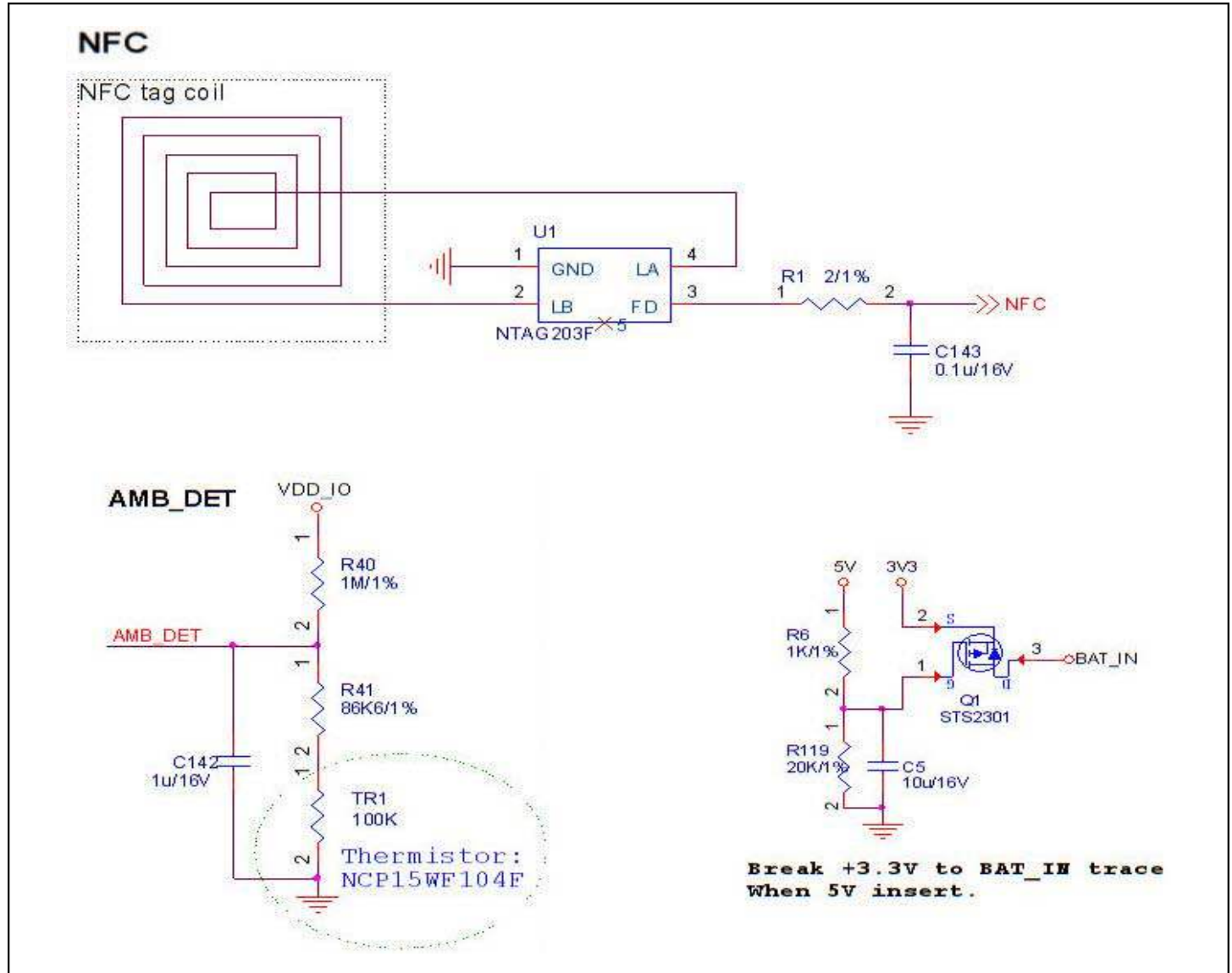
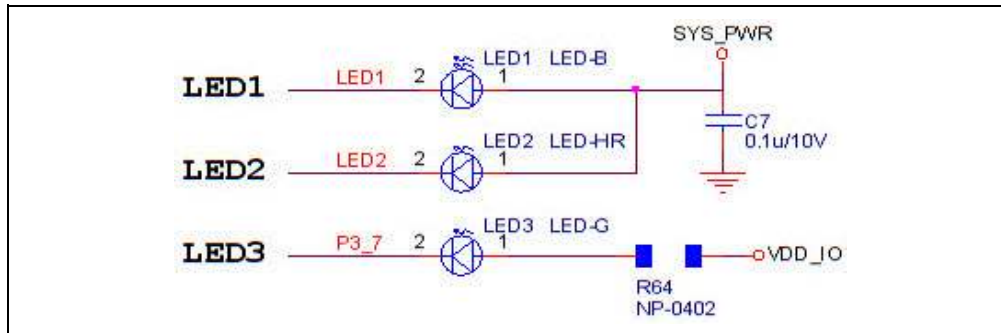


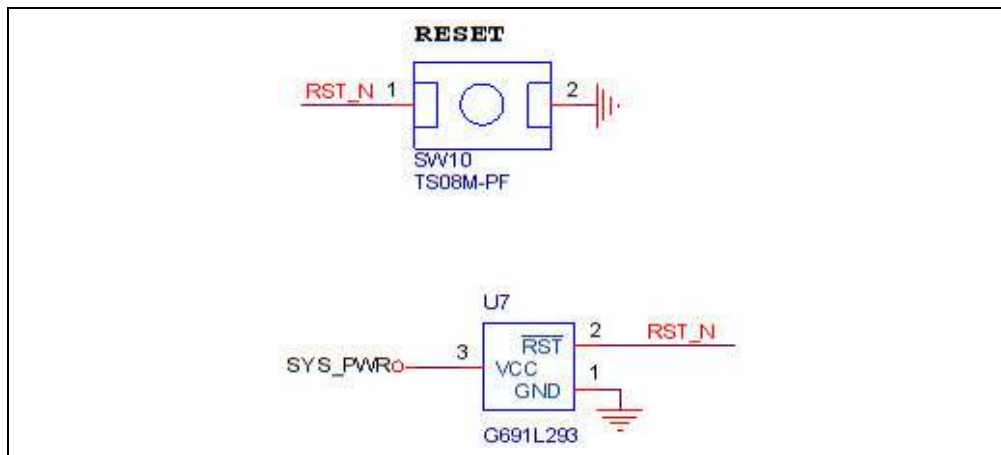
FIGURE A-2: NFC



**FIGURE A-3: STATUS LEDS**



**FIGURE A-4: RESET BUTTON**



**FIGURE A-5: EXTERNAL MCU/DSP HEADER J6**

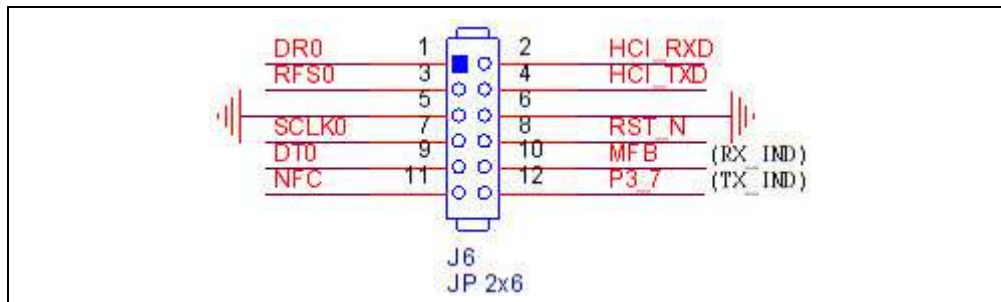


FIGURE A-6: LINE INPUT

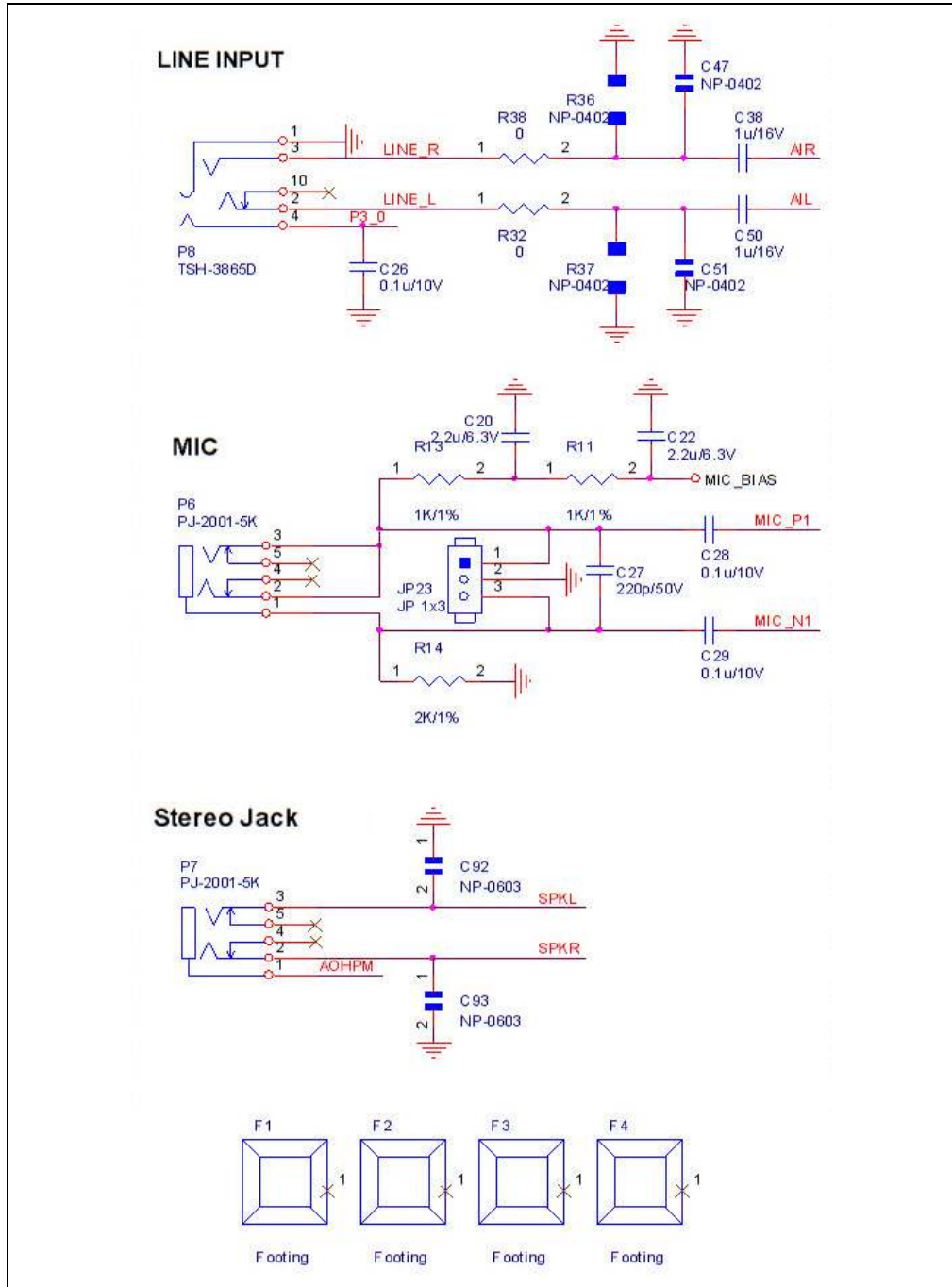




FIGURE A-7: USB TO UART INTERFACE

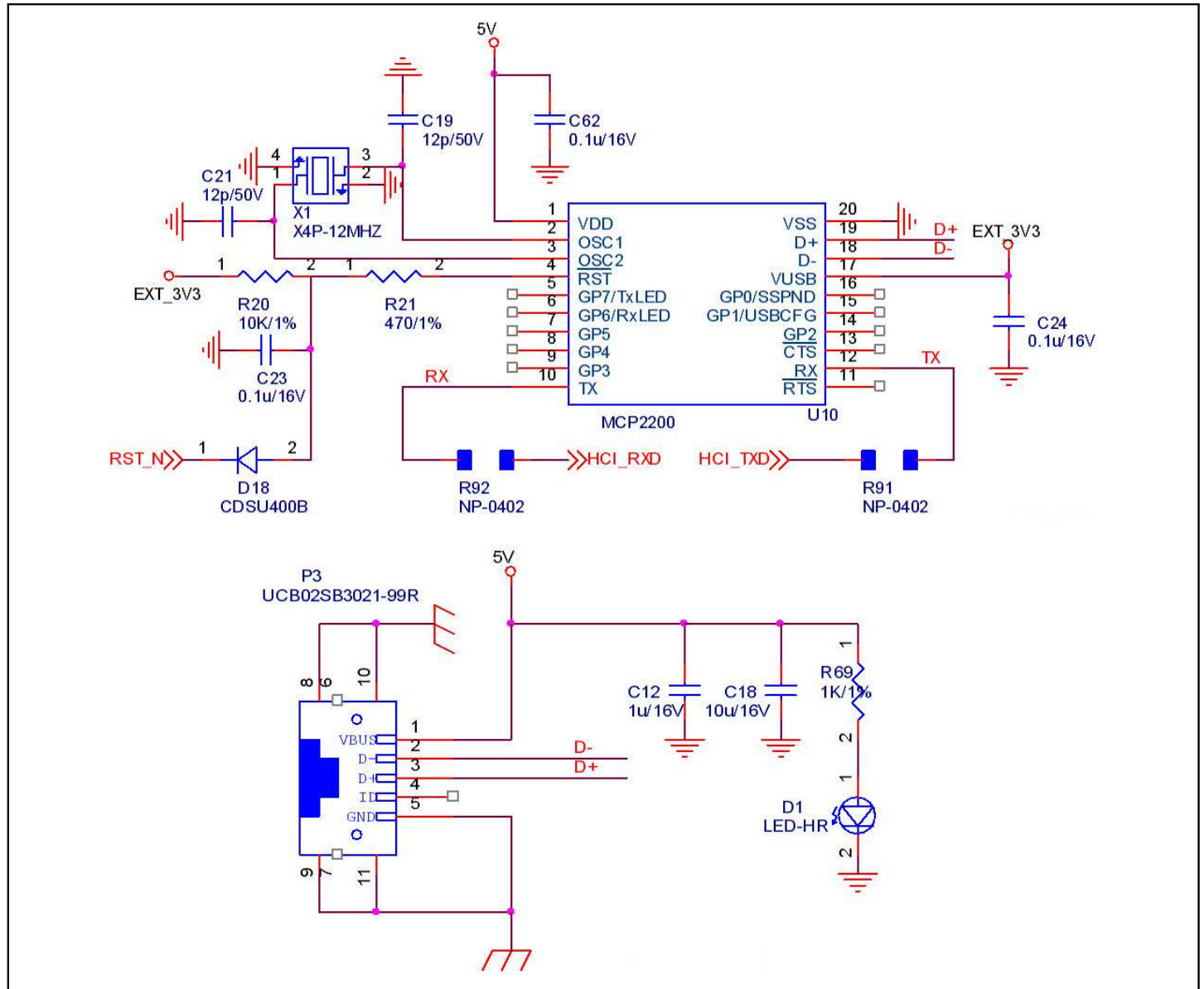
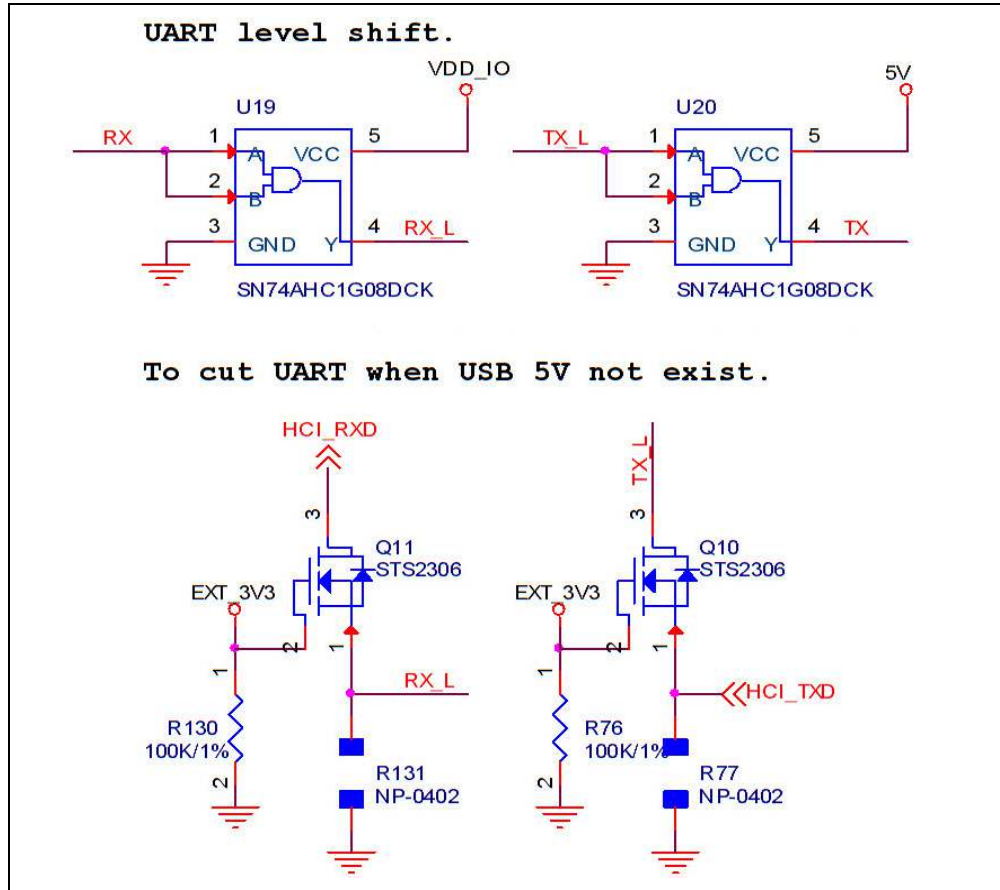


FIGURE A-8: UART INTERFACE



**FIGURE A-9: SWITCH CONFIGURATION**

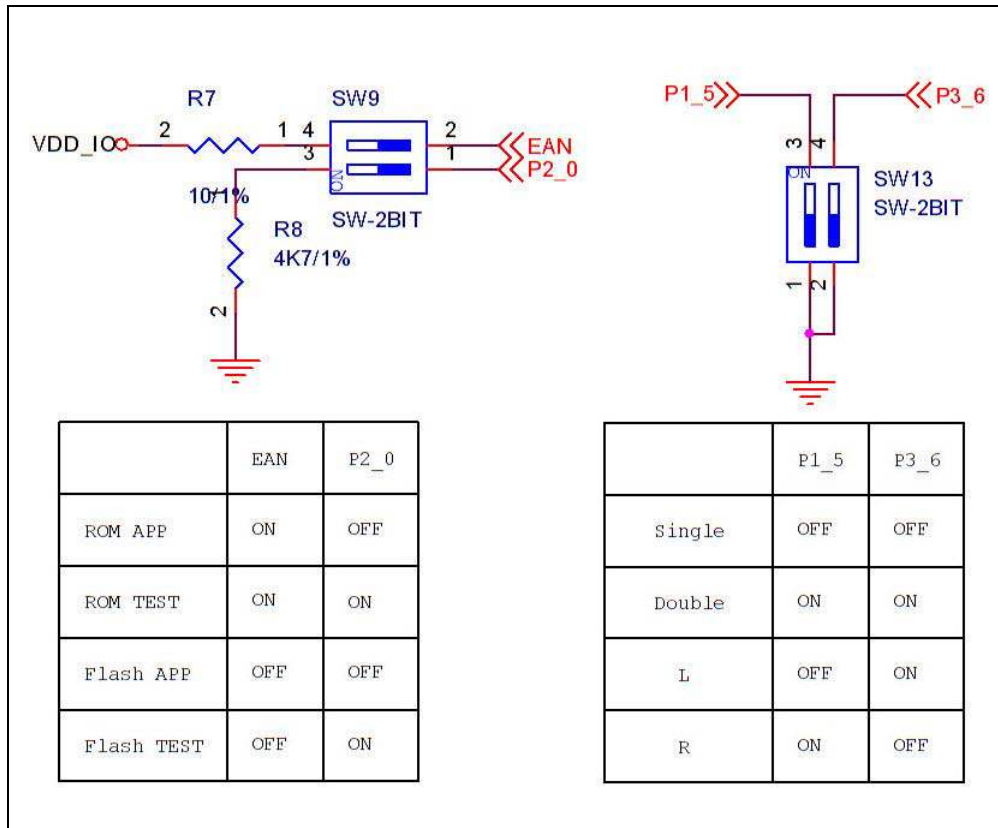
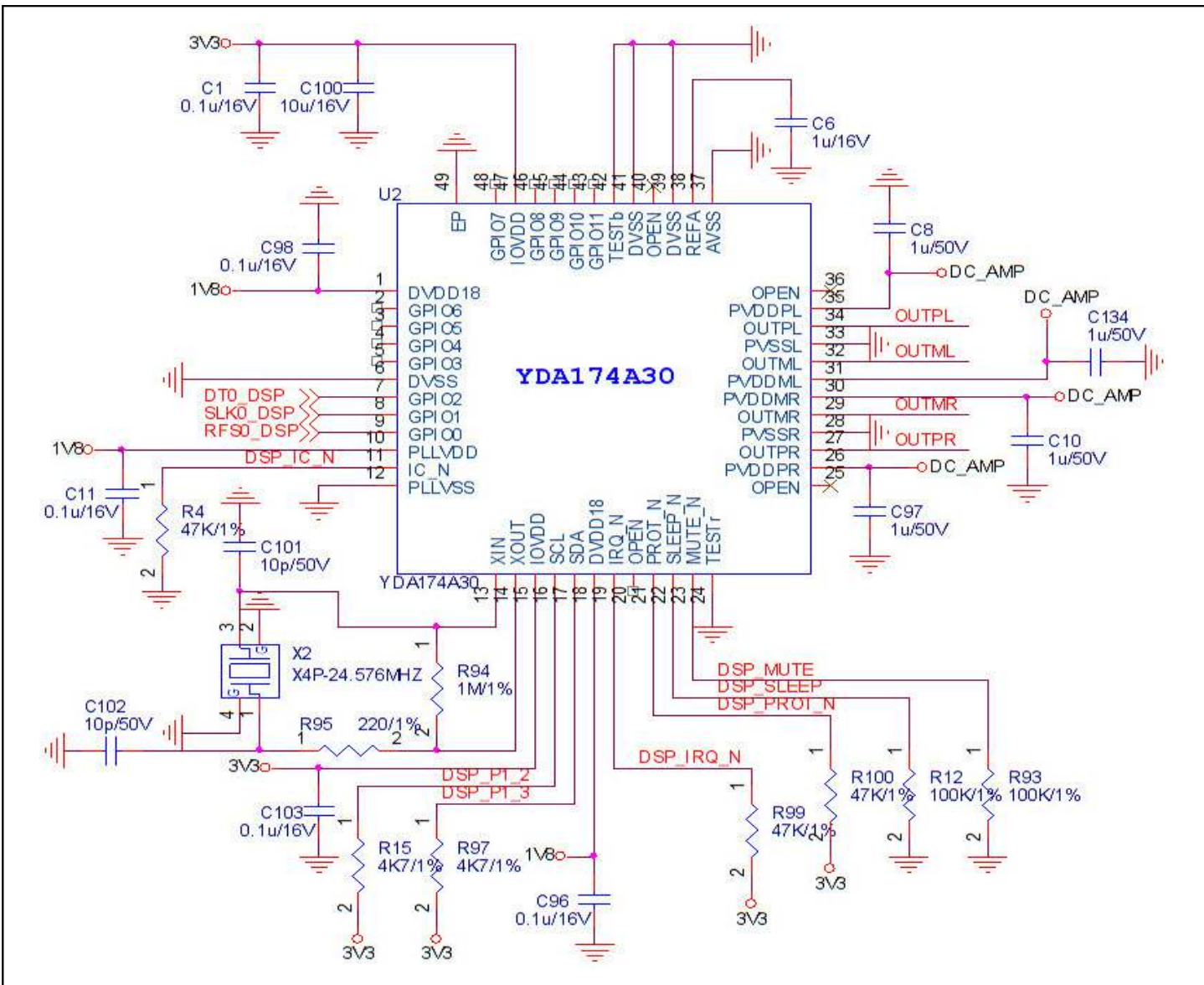
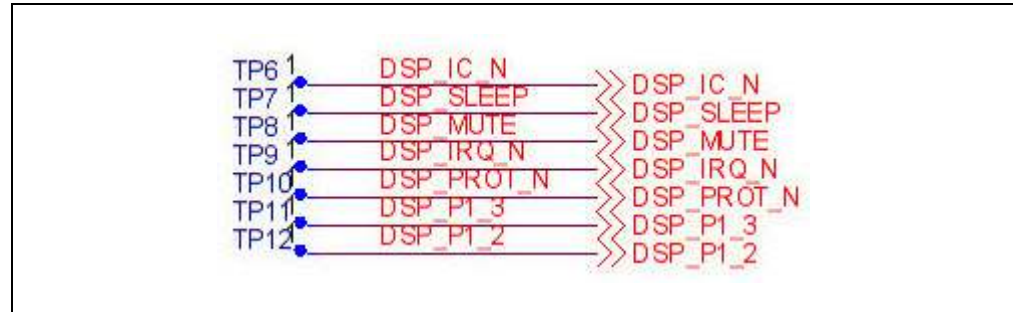


FIGURE A-10: DSP SCHEMATICS



**FIGURE A-11: DSP/MCU INTERFACE**



**FIGURE A-12: POWER SUPPLY**

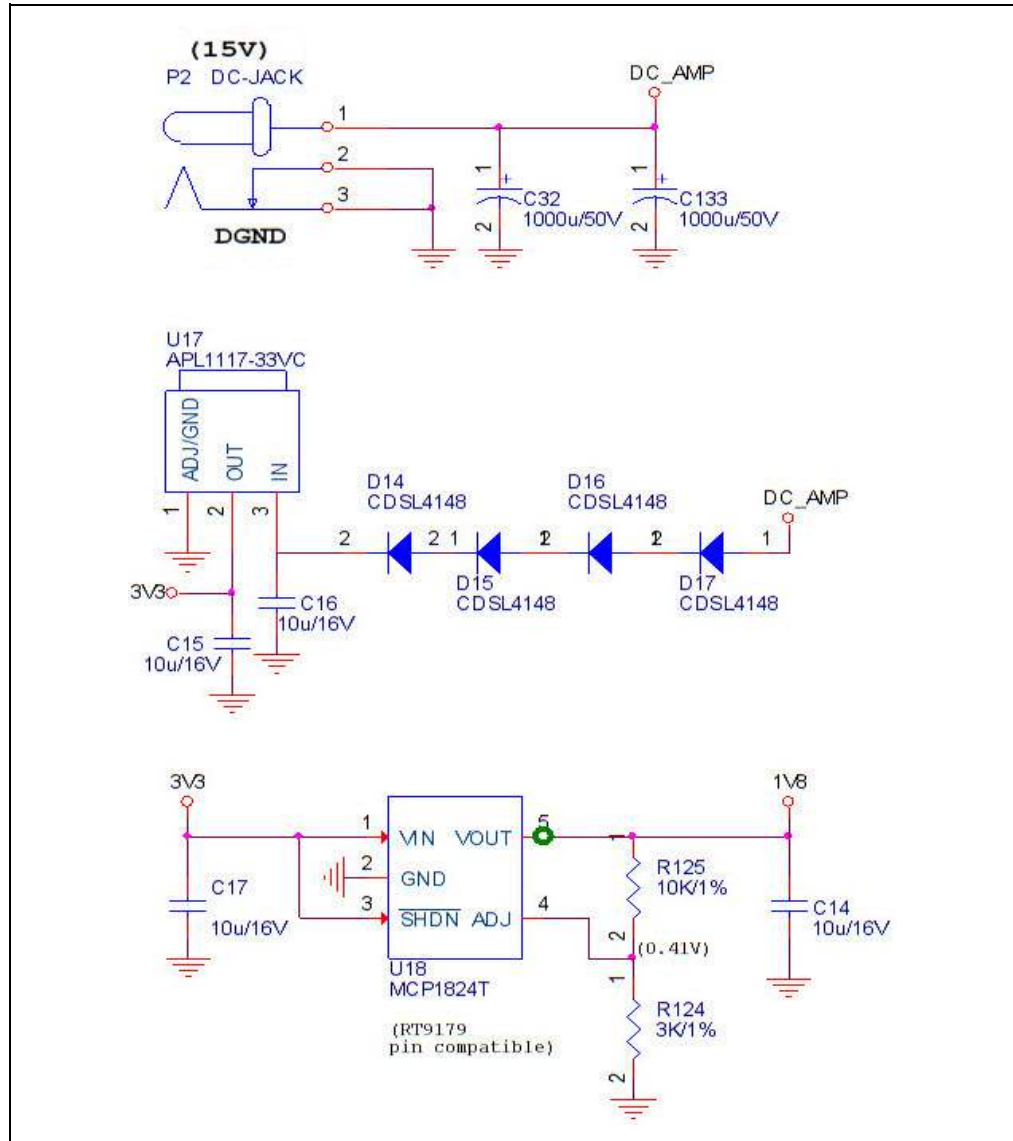


FIGURE A-13: SPEAKER OUTPUT

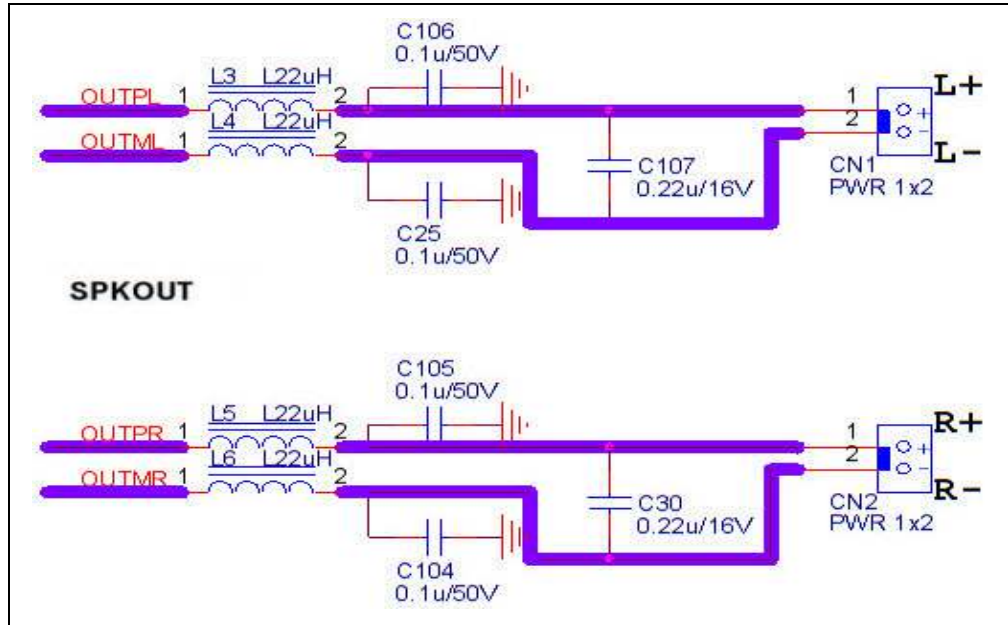
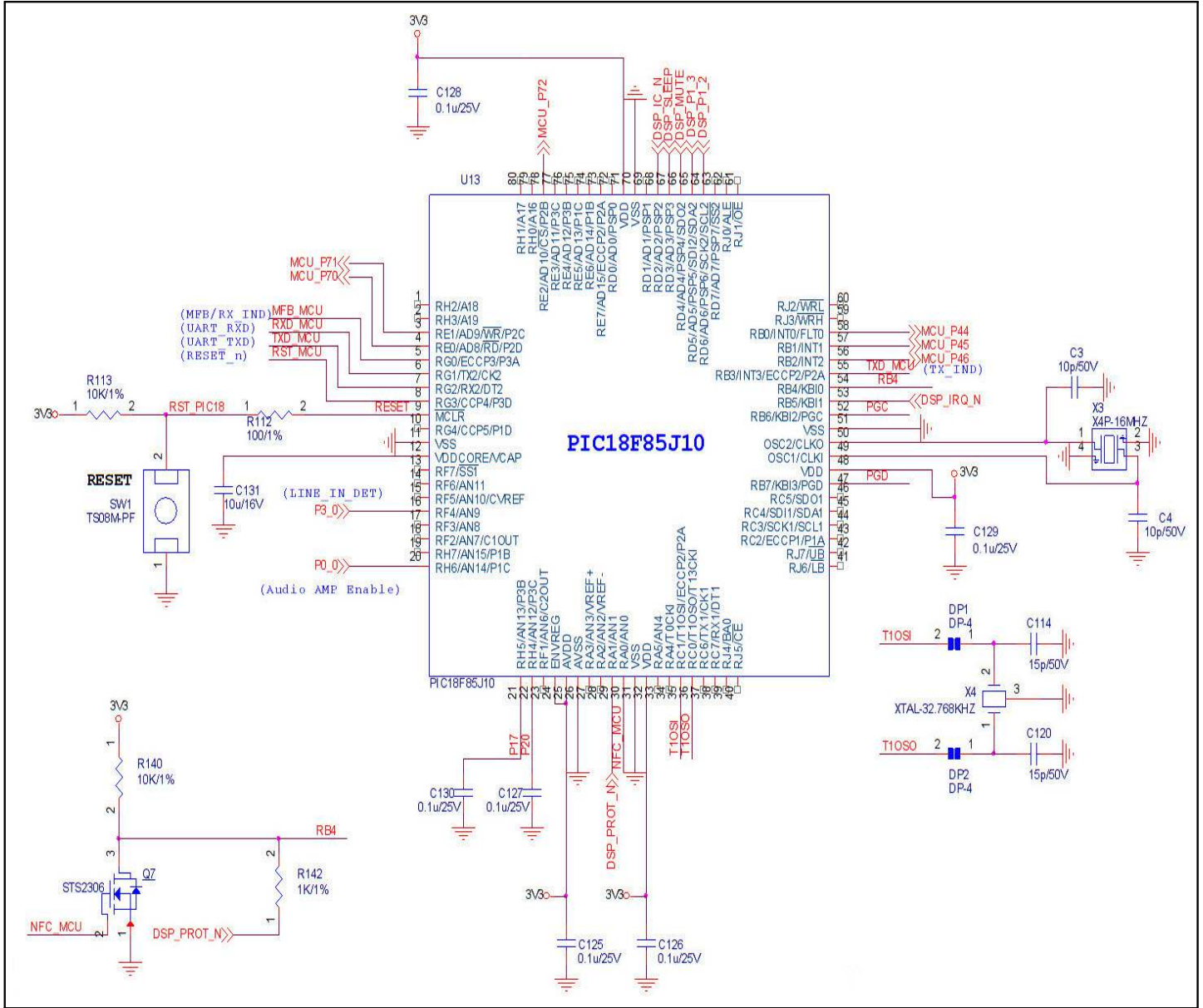
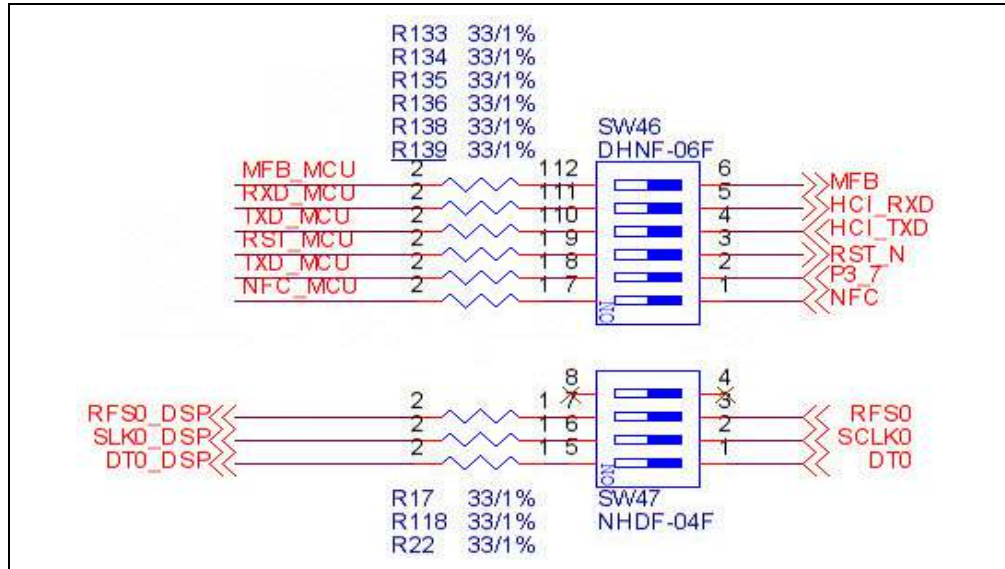


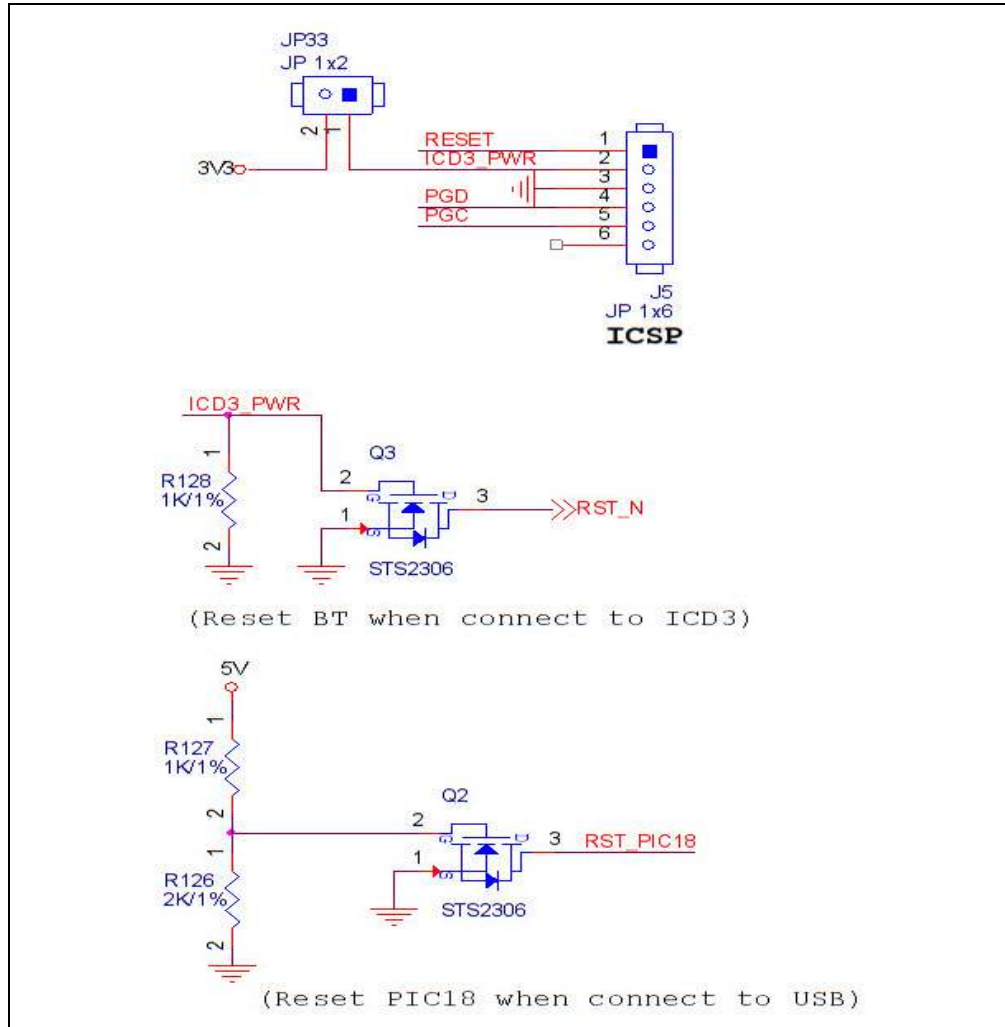
FIGURE A-14: EXTERNAL MCU INTERFACE



**FIGURE A-15: SWITCH SW46/SW47 CONFIGURATION**

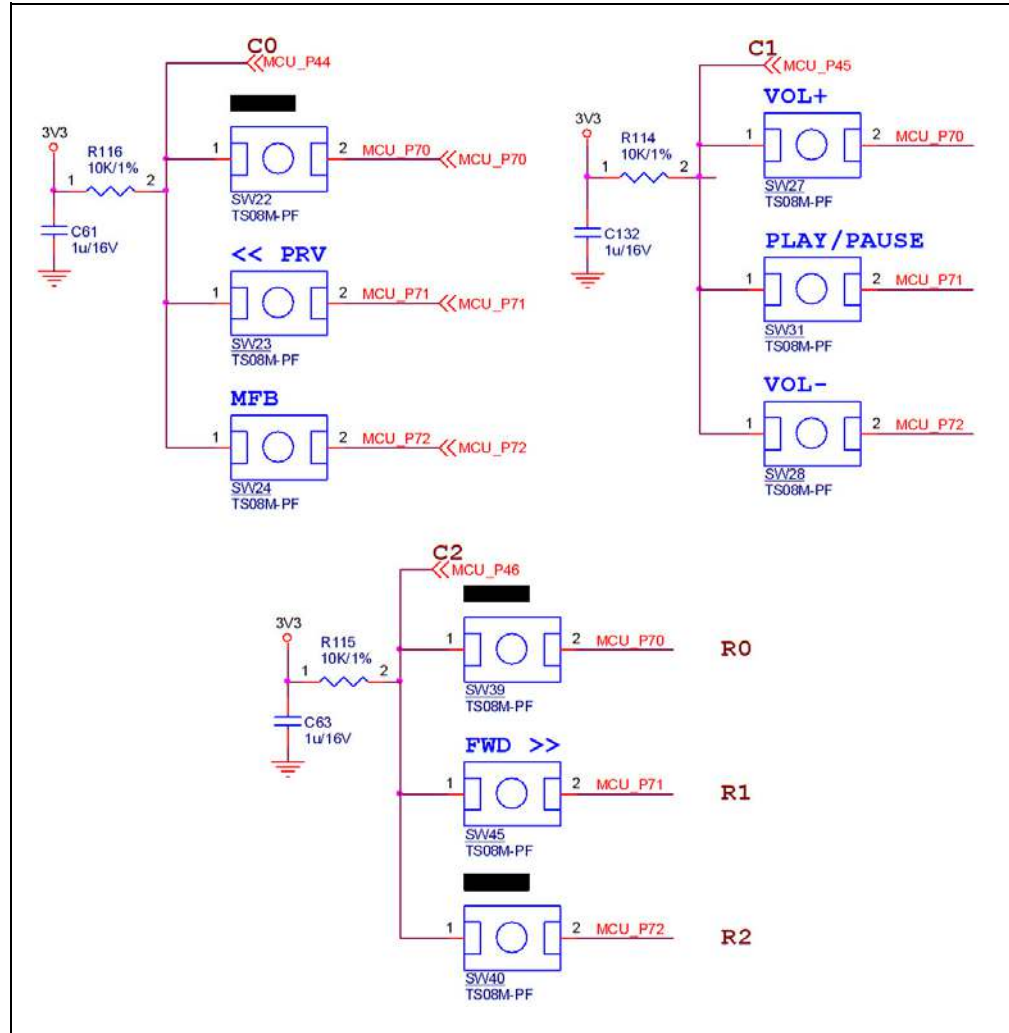


**FIGURE A-16: ICSP**





**FIGURE A-17: PUSH BUTTONS**



# BM64 EVB User's Guide

---

NOTES:

---

---

**NOTES:**



## Worldwide Sales and Service

### AMERICAS

**Corporate Office**  
2355 West Chandler Blvd.  
Chandler, AZ 85224-6199  
Tel: 480-792-7200  
Fax: 480-792-7277  
Technical Support:  
<http://www.microchip.com/support>  
Web Address:  
[www.microchip.com](http://www.microchip.com)

**Atlanta**  
Duluth, GA  
Tel: 678-957-9614  
Fax: 678-957-1455

**Austin, TX**  
Tel: 512-257-3370

**Boston**  
Westborough, MA  
Tel: 774-760-0087  
Fax: 774-760-0088

**Chicago**  
Itasca, IL  
Tel: 630-285-0071  
Fax: 630-285-0075

**Dallas**  
Addison, TX  
Tel: 972-818-7423  
Fax: 972-818-2924

**Detroit**  
Novi, MI  
Tel: 248-848-4000

**Houston, TX**  
Tel: 281-894-5983

**Indianapolis**  
Noblesville, IN  
Tel: 317-773-8323  
Fax: 317-773-5453  
Tel: 317-536-2380

**Los Angeles**  
Mission Viejo, CA  
Tel: 949-462-9523  
Fax: 949-462-9608  
Tel: 951-273-7800

**Raleigh, NC**  
Tel: 919-844-7510

**New York, NY**  
Tel: 631-435-6000

**San Jose, CA**  
Tel: 408-735-9110  
Tel: 408-436-4270

**Canada - Toronto**  
Tel: 905-695-1980  
Fax: 905-695-2078

### ASIA/PACIFIC

**Australia - Sydney**  
Tel: 61-2-9868-6733

**China - Beijing**  
Tel: 86-10-8569-7000

**China - Chengdu**  
Tel: 86-28-8665-5511

**China - Chongqing**  
Tel: 86-23-8980-9588

**China - Dongguan**  
Tel: 86-769-8702-9880

**China - Guangzhou**  
Tel: 86-20-8755-8029

**China - Hangzhou**  
Tel: 86-571-8792-8115

**China - Hong Kong SAR**  
Tel: 852-2943-5100

**China - Nanjing**  
Tel: 86-25-8473-2460

**China - Qingdao**  
Tel: 86-532-8502-7355

**China - Shanghai**  
Tel: 86-21-3326-8000

**China - Shenyang**  
Tel: 86-24-2334-2829

**China - Shenzhen**  
Tel: 86-755-8864-2200

**China - Suzhou**  
Tel: 86-186-6233-1526

**China - Wuhan**  
Tel: 86-27-5980-5300

**China - Xian**  
Tel: 86-29-8833-7252

**China - Xiamen**  
Tel: 86-592-2388138

**China - Zhuhai**  
Tel: 86-756-3210040

### ASIA/PACIFIC

**India - Bangalore**  
Tel: 91-80-3090-4444

**India - New Delhi**  
Tel: 91-11-4160-8631

**India - Pune**  
Tel: 91-20-4121-0141

**Japan - Osaka**  
Tel: 81-6-6152-7160

**Japan - Tokyo**  
Tel: 81-3-6880-3770

**Korea - Daegu**  
Tel: 82-53-744-4301

**Korea - Seoul**  
Tel: 82-2-554-7200

**Malaysia - Kuala Lumpur**  
Tel: 60-3-7651-7906

**Malaysia - Penang**  
Tel: 60-4-227-8870

**Philippines - Manila**  
Tel: 63-2-634-9065

**Singapore**  
Tel: 65-6334-8870

**Taiwan - Hsin Chu**  
Tel: 886-3-577-8366

**Taiwan - Kaohsiung**  
Tel: 886-7-213-7830

**Taiwan - Taipei**  
Tel: 886-2-2508-8600

**Thailand - Bangkok**  
Tel: 66-2-694-1351

**Vietnam - Ho Chi Minh**  
Tel: 84-28-5448-2100

### EUROPE

**Austria - Wels**  
Tel: 43-7242-2244-39  
Fax: 43-7242-2244-393

**Denmark - Copenhagen**  
Tel: 45-4450-2828  
Fax: 45-4485-2829

**Finland - Espoo**  
Tel: 358-9-4520-820

**France - Paris**  
Tel: 33-1-69-53-63-20  
Fax: 33-1-69-30-90-79

**Germany - Garching**  
Tel: 49-8931-9700

**Germany - Haan**  
Tel: 49-2129-3766400

**Germany - Heilbronn**  
Tel: 49-7131-67-3636

**Germany - Karlsruhe**  
Tel: 49-721-625370

**Germany - Munich**  
Tel: 49-89-627-144-0  
Fax: 49-89-627-144-44

**Germany - Rosenheim**  
Tel: 49-8031-354-560

**Israel - Ra'anana**  
Tel: 972-9-744-7705

**Italy - Milan**  
Tel: 39-0331-742611  
Fax: 39-0331-466781

**Italy - Padova**  
Tel: 39-049-7625286

**Netherlands - Drunen**  
Tel: 31-416-690399  
Fax: 31-416-690340

**Norway - Trondheim**  
Tel: 47-7289-7561

**Poland - Warsaw**  
Tel: 48-22-3325737

**Romania - Bucharest**  
Tel: 40-21-407-87-50

**Spain - Madrid**  
Tel: 34-91-708-08-90  
Fax: 34-91-708-08-91

**Sweden - Gothenberg**  
Tel: 46-31-704-60-40

**Sweden - Stockholm**  
Tel: 46-8-5090-4654

**UK - Wokingham**  
Tel: 44-118-921-5800  
Fax: 44-118-921-5820