

Switching Power Supply S82D

High-Grade Power Supply for Demanding Industrial Applications

- Wide range of output voltages: 5 V or 12 V.
- Selectable 85 to 132 VAC or 170 to 264 VAC input voltage.
- Equipped with overvoltage and overload protection, remote sensing and remote control functions.
- Fan alarm signal warns of possible fan malfunction.
- For loads drawing high current, parallel connection of two power supplies possible.
- Two pairs of output terminals simplify wiring of two loads (300 W).
- Optional multiple output terminal available (600 W).
- 3-year warranty.



Ordering Information

■ SWITCHING POWER SUPPLIES

Stock Note: Shaded models are normally stocked.

Rated input voltage	Power ratings	Output		Part number
		Voltage	Current	
120/240VAC	300 W	5 VDC	60 A	S82D-3005
		12 VDC	27 A	S82D-3012
	600 W	5 VDC	120 A	S82D-6005
		12 VDC	53 A	S82D-6012

Note: For mounting brackets and other accessories, refer to the *Accessories* Section on the next page.

■ MODEL NUMBER LEGEND

S82D -
1 2

1. Power ratings
 30: 300 W
 60: 600 W

2. Output voltage
 05: 5 V
 12: 12 V
 24: 24 V

■ ACCESSORIES (ORDER SEPARATELY)

Stock Note: Shaded models are normally stocked.

Item	Mounting type	Applicable power supply	Part number
Mounting brackets	Bottom mounting	S82D-30□□	S82Y-D30B
		S82D-60□□	S82Y-D60B
	Side mounting	S82D-30□□	S82Y-D30S
		S82D-60□□	S82Y-D60S
Terminal expansion bracket		S82D-60□□	S82Y-D60T
Connection kit	Parallel	S82D-30□□	S82Y-D30A
		S82D-60□□	S82Y-D60A
Fan		S82D-30□□	S82Y-DFAN
		S82D-60□□	

Specifications

Power rating	300 W		600 W
Efficiency (typical)	74% to 84% (depending on types)		
Life expectancy	10 yrs. min. (used at 40°C at the rated input with a 50% load) The life expectancy of the fan is lower.		
Input			
Voltage (AC only)	120 V (85 to 132 V) or 240 V (170 to 264 V) selectable		
Frequency	47 to 450 Hz		
Current (with rated I/O)	100-V input	8 A max.	14 A max.
	200-V input	4 A max.	7 A max.
Leakage current (with rated I/O)	100-V input	0.5 mA max.	
	200-V input	1 mA max.	
Inrush current (with rated I/O)	100-V input	25 A typ.	30 A typ.
	200-V input	50 A typ.	60 A typ.
Noise filter	Yes		
Output			
Voltage fluctuation	3% max. (combined input, load, and temperature variations)		
Voltage adjustment range	±10%, adjustable with variable resistor (V.ADJ)		
Ripple	2% (p-p) max.		
Input variation influence	0.4% max. (85 to 132 VAC/170 to 264 VAC input, 100% load)		
Load variation influence	0.8% max. (rated input, 0% to 100% load)		
Temperature variation influence	0.04%/°C max. (0° to 50°C, with rated input and output)		
Rise time	300 ms max. (output voltage rise to 90%, with rated input and output)		
Hold time	20 ms min.		
Additional functions			
Overload protection	120% of rated load current (typical), inverted L drop, automatic reset (output shut off after 5 s, reset by input reset)		
Overvoltage protection	120% of rated output voltage (typical), shut-off type, reset by input reset		
Fan alarm	Relay output, connector SPST, 250 VAC, 1 A load resistance, but switching capacity is 125 VA		
Remote sensing	Yes		
Remote control	Yes		
Parallel connection	Yes		

(This table continues on the next page.)

Specifications Table – continued from previous page

Power rating	300 W	600 W
Characteristics		
Ambient temperature	Operating	See the derating curve in the <i>Engineering Data</i> section
	Storage	-25°C to 85°C (-13°F to 185°F)
Ambient humidity	Operating	25% to 85%
	Storage	25% to 95%
Dielectric strength (see note below table)	2000 VAC, 50/60Hz for 1 min (between all inputs and outputs/housing) 500 VDC for 1 min (between all inputs and outputs/housing)	
Insulation resistance (see note below table)	100 MΩ min. at 500 VDC (between all outputs and inputs/housing)	
Vibration resistance	Malfunction: 10 to 55 Hz, 0.75-mm double amplitude (approx. 4.5G) each in X, Y, and Z directions for 2 hours.	
Shock resistance	Malfunction: 294 m/s ² (30G), 3 times each in ±1X, ±1Y, and ±1Z directions	
Output indicator	Yes (red)	
Electromagnetic interference	Meets FCC class A standards	
Approved standards	UL 1012, CSA E.B. 1402	
Weight	2.5 kg max.	4 kg max.

Note: Be sure to remove short bar attached between FC and ACG terminals before performing dielectric strength test or insulation resistance test because surge absorber is connected across input lines.

Engineering Data

■ DERATING CURVE

Note: The derating curve differs depending on the mounting position of the power supply. The curve above was obtained with the power supply mounted in the standard position.

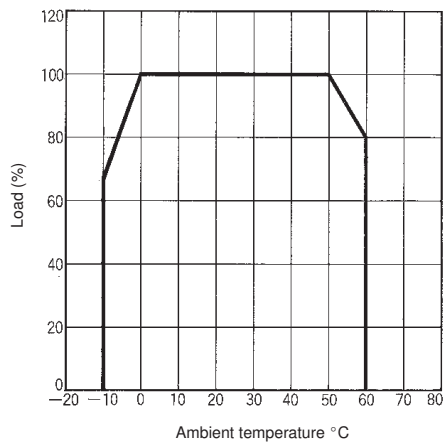

■ OVERVOLTAGE PROTECTION

The protective function prevents damage to the load and to the power supply itself (from overvoltage). The output is shut off if the output voltage rises above about 120% of the rated voltage. The input power must be turned off for at least 30 s. Then, turn it on again to reset the power supply.

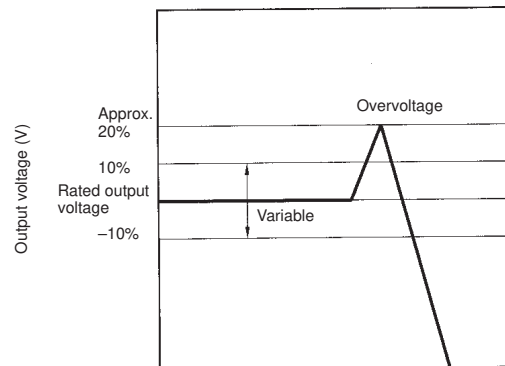

OVERLOAD PROTECTION

The protective function prevents damage to the load as well as to the power supply itself due to overload. If the load current rises above the overload set value (105% to 135% of the rated load current), the protective function will engage, and the voltage will be reduced. Reset is automatic, so the power supply will return to normal operation when the overload condition is corrected.

If the output voltage falls below 70% of the rated value in an overload condition, the low-voltage sensing circuit will engage and shut off the output if the low voltage condition continues for more than 5 s. In this situation, reset is not automatic. To reset the power supply, turn off the input power for at least 30 s and then turn it on again.

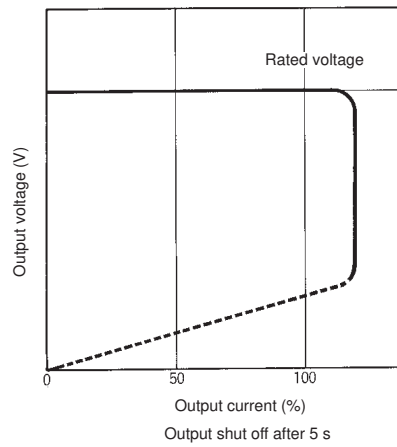

INRUSH CURRENT, START UP TIME, HOLD TIME

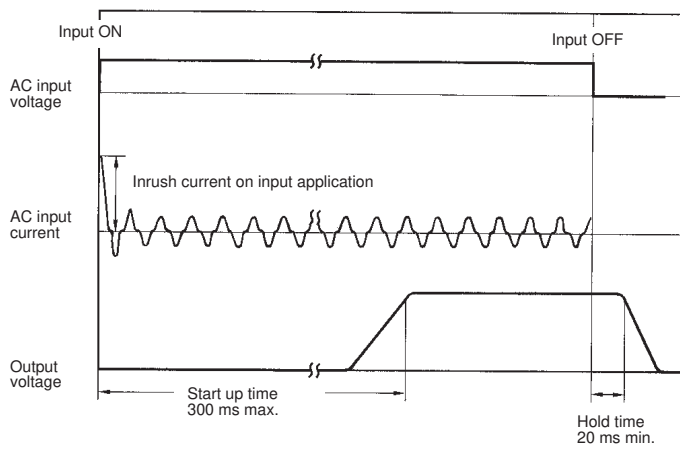

Nomenclature

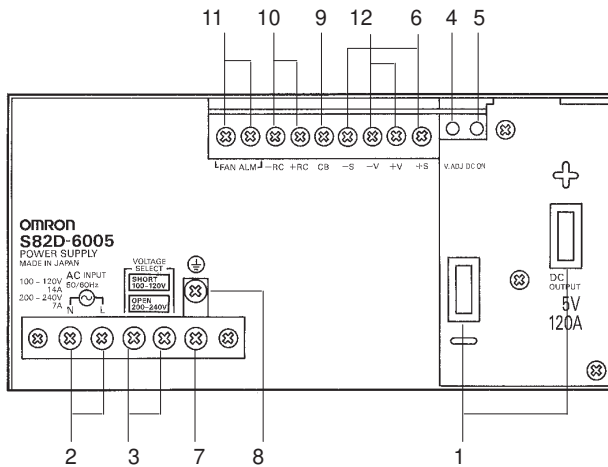
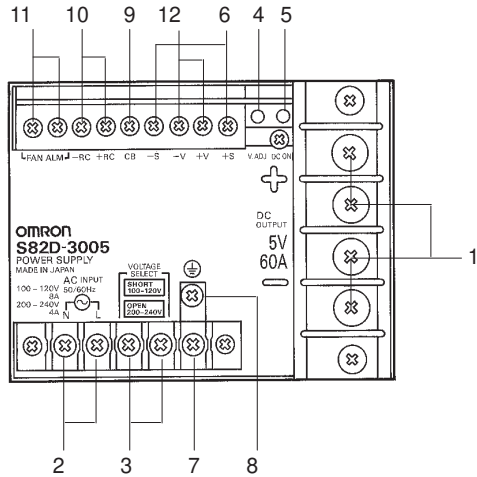

1. **DC Output Terminals:** Connect load wiring.
2. **Input Terminals:** Connect input wiring.
3. **Voltage Select Terminals:** Switch the input voltage by connecting or removing the short bar. (short circuited: 100 to 120 V; open: 200 to 240 V)
4. **V. ADJ Adjustor:** Use to adjust the output voltage.
5. **Output LED Indicator:** Lights when DC current is being output.
6. **Remote Sensing Terminals:** These correct the voltage drop in the load lines.
7. **ACG Terminal:** The intermediate point of the input filter. Shorted to FG terminal for normal operation.
8. **FG Terminal:** Shorted to the housing, and connected to a ground line.
9. **Current Balance Terminal:** Connected to the CB terminal of another Power Supply wired in parallel.
10. **Remote Control Terminals:** Connected to an external device to enable remote control of the output while the input voltage is being applied.
11. **Fan Alarm Output:** Turns ON (shorted) when the speed of the internal fan drops.
12. **Output Voltage Monitoring Terminals:** Take-off from the DC output terminals. Connected to the remote sensing terminals (+S and -S) when the remote sensing function is not used.

Operation

REMOTE SENSING FUNCTION

This function corrects a voltage drop in the load wiring. When using the remote sensing function, remove the short bars from the remote sensing terminals as shown in the following diagram.

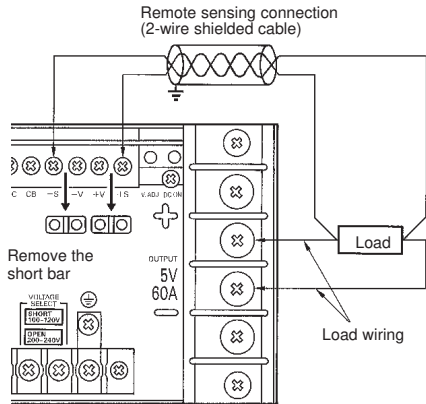

- Note: 1. When the voltage drop in the load wiring is large, the overvoltage protection function might engage just from the increase in voltage to correct the voltage drop, so be sure to use high capacity wiring.
2. If the +S and +V terminals are left unconnected, the high voltage protection function will engage and the output voltage will be cut off. If the -S and -V terminals are left unconnected, the output voltage will increase about 5%.

REMOTE CONTROL FUNCTION

This function allows the output voltage to be turned on and off with an external signal (as long as the input voltage is being applied). When using the remote control function, remove the short bar from the remote control terminals and connect a switch or transistor as shown in the diagram below. The remote control circuit is insulated from input, output, and GR.

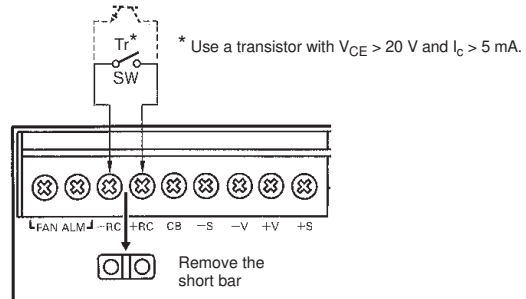

Voltage level	Output voltage
Low: (0.8 V max.)	ON
High: (2 V min.)	OFF

FAN ALARM

When the speed of the internal fan drops, the fan alarm output (SPST-NO) will turn ON (shorted).

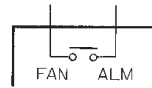

Normal condition

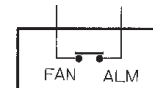

Alarm condition

BLOCK DIAGRAM

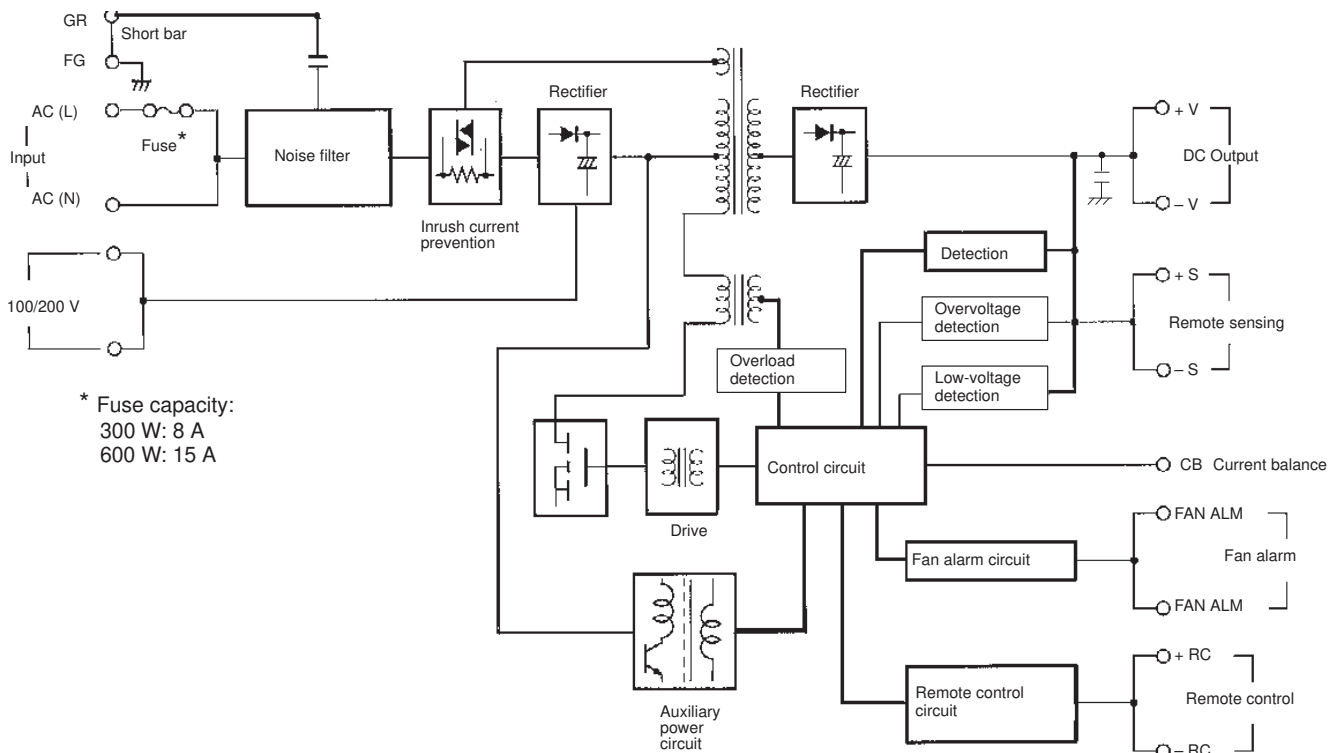

■ SWITCHING THE INPUT VOLTAGE BETWEEN 120 V AND 240 V

- Select 100 to 120 or 200 to 240 V input voltage by shorting or opening the input voltage switching terminals, as shown in the diagram below. (Factory set at 200 to 240 V operation.)

100 to 120 V Input

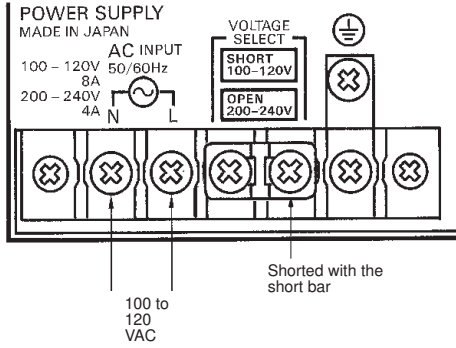

200 to 240 V Input

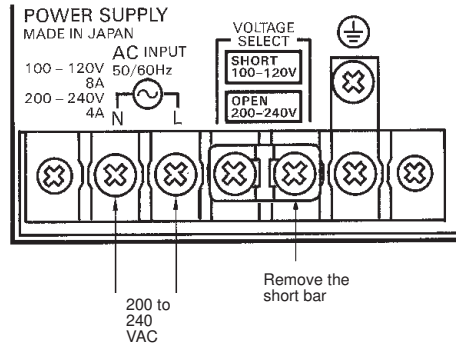

■ GENERATING OUTPUT VOLTAGES (\pm)

S82D power supplies may be connected to provide floating output voltages (\pm) as shown below.

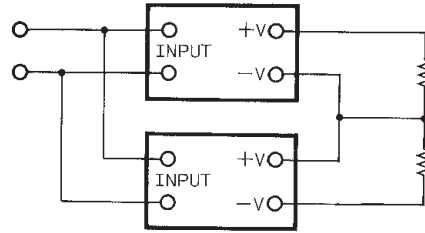

■ SERIES CONNECTION

The output of two power supplies can be combined in series to double the output voltage as shown below.

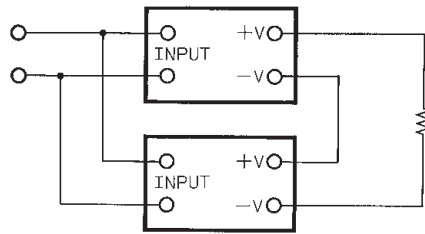

PARALLEL CONNECTION (MASTER/SLAVE OPERATION)

The S82D power supply has a built-in current balance function, allowing two units to be connected in parallel (master/slave operation) increasing the output current. A maximum of two units can be connected in parallel.

Master/Slave Operation

When connecting two power supplies for master/slave operation, use shielded wire to connect the current balance (CB) and -S terminals as shown below.

In master/slave operation, the power supply with the lower voltage adjustment set value (controlled by V. ADJ) is the master unit, and the power supply with the higher voltage adjustment set value is the slave unit.

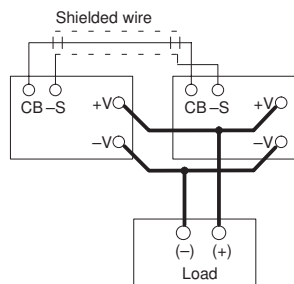

Note: A maximum of two units can be connected in parallel.

Wiring

Use high capacity wiring between the power supplies and the load in order to minimize voltage drops due to wire resistance. A parallel connection kit, sold separately, is available. (Refer to the *Ordering Information* section of this data sheet.) The kit includes a bar to connect the outputs and shielded wire to connect the current balance and -S terminals.

Power supply	Connection kit
S82D-300 W	S82Y-D30A
S82D-600 W	S82Y-D60A

Wiring Specifications

When using lead wires, the wires should meet the specifications in the following table.

Model	Cross sectional area	Length
S82D-3005	14 mm ² min.	30 cm max.
	8 mm ² min.	20 cm max.
S82D-3012	8 mm ² min.	30 cm max.
	5.5 mm ² min.	20 cm max.
S82D-3024	8 mm ² min.	50 cm max.
	5.5 mm ² min.	30 cm max.
S82D-6005	20 mm ² min.	30 cm max.
	14 mm ² min. (2 wires min.)	30 cm max.
S82D-6012	14 mm ² min.	30 cm max.
	8 mm ² min. (2 wires min.)	30 cm max.
S82D-6024	8 mm ² min.	30 cm max.
	5.5 mm ² min. (2 wires min.)	30 cm max.

Correct Wiring

To ensure that the voltage drop is the same between each power supply and load, the length and cross sectional area of the wires used should be uniform. Wire the system as shown in the figure below.

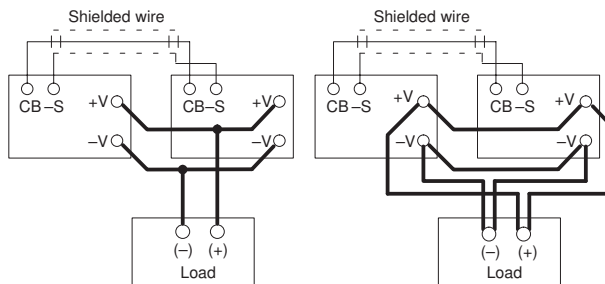

Incorrect Wiring

Do not wire the power supplies as shown below. It would cause output voltage imbalance: one of the units would supply excessive current, causing the overload protection to engage. The result would be an unstable current and a reduction in product life expectancy.

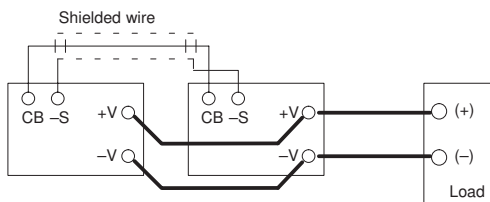

Adjusting the Output Voltage (Master/Slave Operation)

Follow the procedure below when adjusting the output voltage of a master/slave system.

1. Connect the two power supplies in parallel and decide which unit will be the master.
2. Turn the voltage adjuster (V. ADJ) of the slave unit completely clockwise.
3. Adjust the voltage adjuster (V. ADJ) of the master unit to the desired voltage.
4. Slowly turn the voltage adjuster (V. ADJ) of the slave unit counterclockwise and set the value just before the output voltage drop.

Note: 1. Set equal output voltages for both power supplies for safety reasons. If the master power supply stops operating due to input failure or breakage, the set output value of the slave power supply will be the output.
2. Even if one power supply fails to operate, both output LED indicators may be lit if the other power supply is in operation.

Dimensions

Unit: mm (inch)

SWITCHING POWER SUPPLIES

S82D-30□□ (300 W)

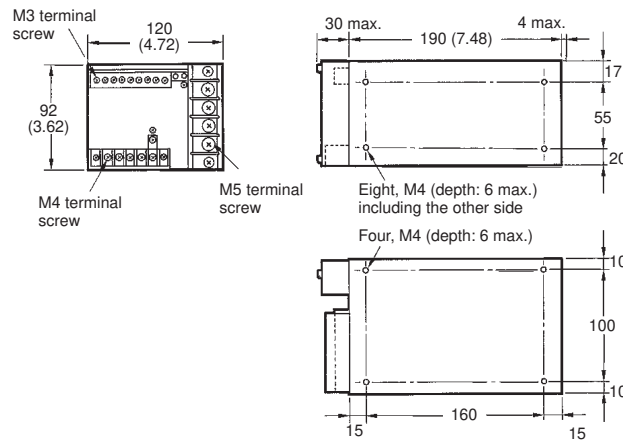
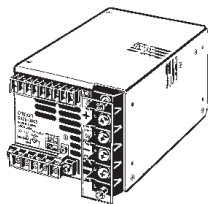

Mounting Holes
Side View

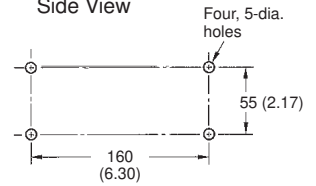

Bottom View

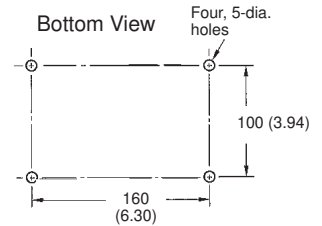

S82D-60□□ (600 W)

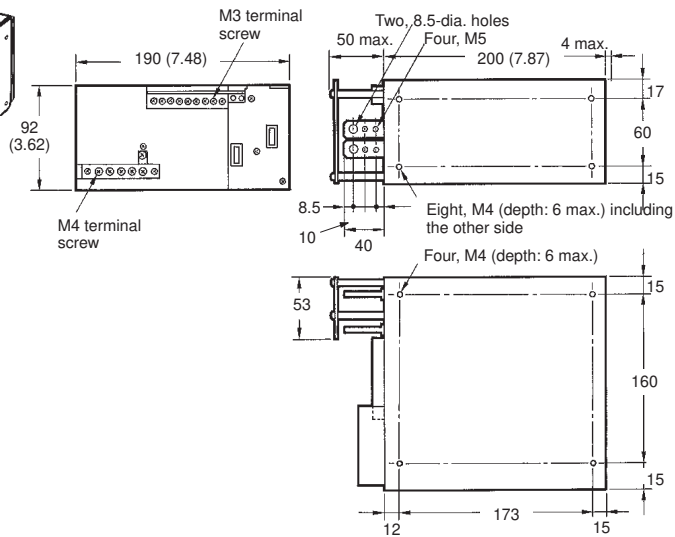
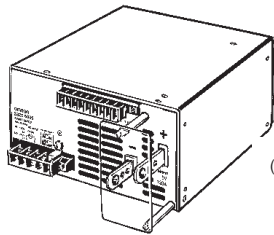

Mounting Holes
Side View

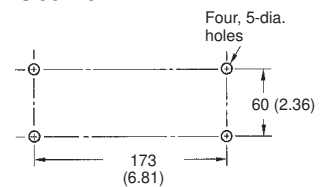

Bottom View

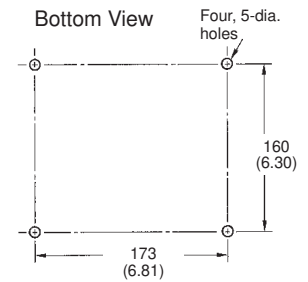

Unit: mm (inch)

■ MOUNTING BRACKETS (ORDER SEPARATELY)

Bottom Mounting

S82Y-D30B for S82D-30□□

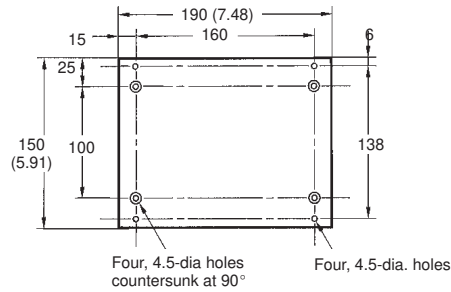
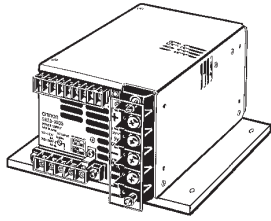

Mounting Holes
Four, M4

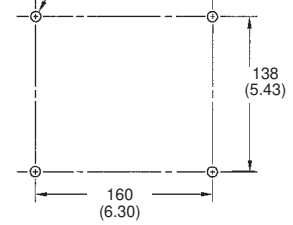

S82Y-D60B for S82D-60□□

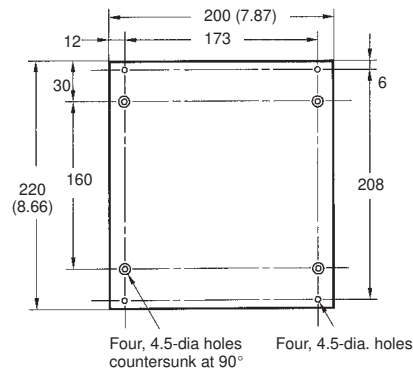
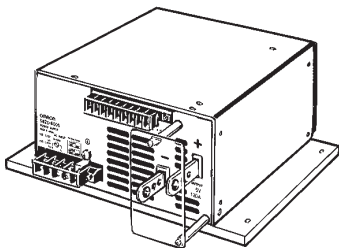

Mounting Holes

Four, M4

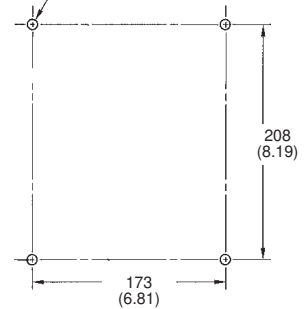

Side Mounting

S82Y-D30S for S82D-30□□

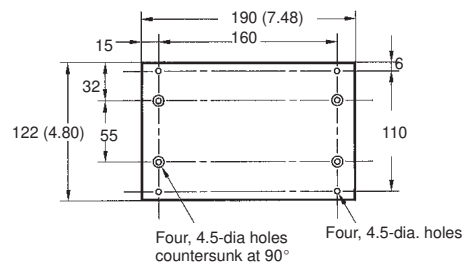
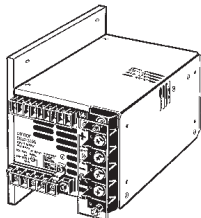

Mounting Holes

Four, M4

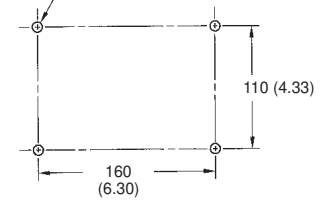

S82Y-D60S for S82D-60□□

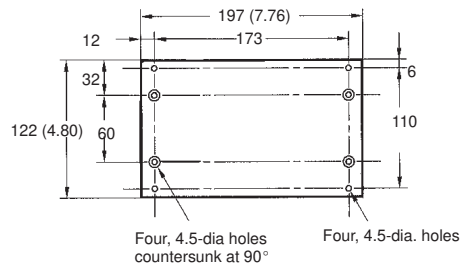
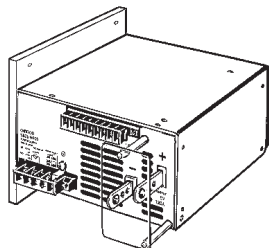

Mounting Holes

Four, M4

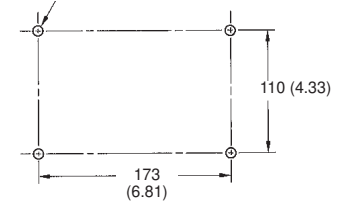

Precautions

■ MOUNTING

Ventilation Holes and Adequate Air Circulation

- To extend its long-term reliability, provide adequate cooling when installing the power supply.
- When installing two or more power supplies side-by-side, allow at least 20 mm (0.79) spacing between them, as shown in the diagram below.

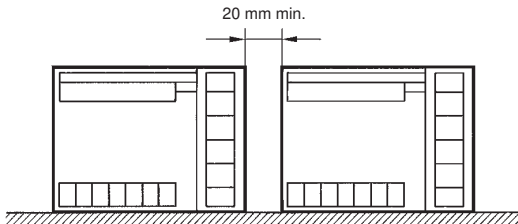

- The ventilation holes in the front and back surfaces of the unit must remain free of obstruction. The power supply is cooled by air forced through it by the internal fan. Minimum distances are indicated here.

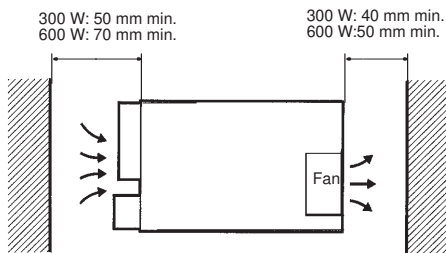

Minimize Dirt and Dust

- Take precautions to minimize dirt, dust, and other airborne debris which could interfere with the forced-air cooling.

■ REPLACING THE FAN

Fan Alarm

- It is necessary to replace the internal fan when the fan alarm output goes ON.

Note: Replacement fan S82Y-DFAN can be ordered through your dealer.

- To replace the fan, remove the back cover as shown in the diagram below.

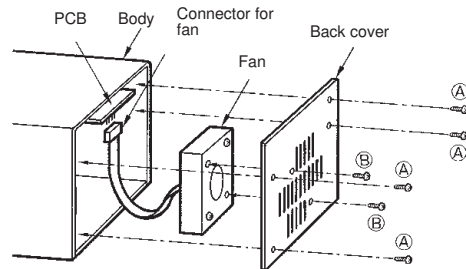

■ TERMINAL EXPANSION BRACKET

For 600 W Power Supplies

- When several loads need to be connected for 600-W Power Supplies, use a terminal expansion bracket (as shown below).

Note: Refer to the *Ordering Information* section of this data sheet.

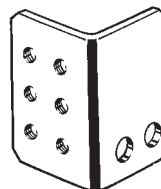

S82Y-D60T

Brackets: 2
M4 x 8 terminal screws: 12
M5 x 12 terminal screws: 4

Certain Terms and Conditions of Sale

1. **Offer: Acceptance.** These terms and conditions (these "Terms") are deemed part of all catalogs, manuals or other documents, whether electronic or in writing, relating to the sale of goods or services (collectively, the "Goods") by Omron Electronics LLC and its subsidiary companies ("Seller"). Seller hereby objects to any terms or conditions proposed in Buyer's purchase order or other documents which are inconsistent with, or in addition to, these Terms. Please contact your Omron representative to confirm any additional terms for sales from your Omron company.
2. **Prices.** All prices stated are current, subject to change without notice by Seller. Buyer agrees to pay the price in effect at time of shipment.
3. **Discounts.** Cash discounts, if any, will apply only on the net amount of invoices sent to Buyer after deducting transportation charges, taxes and duties, and will be allowed only if (i) the invoice is paid according to Seller's payment terms and (ii) Buyer has no past due amounts owing to Seller.
4. **Orders.** Seller will accept no order less than \$200 net billing.
5. **Governmental Approvals.** Buyer shall be responsible for, and shall bear all costs involved in, obtaining any government approvals required for the importation or sale of the Goods.
6. **Taxes.** All taxes, duties and other governmental charges (other than general real property and income taxes), including any interest or penalties thereon, imposed directly or indirectly on Seller or required to be collected directly or indirectly by Seller for the manufacture, production, sale, delivery, importation, consumption or use of the Goods sold hereunder (including customs duties and sales, excise, use, turnover and license taxes) shall be charged to and remitted by Buyer to Seller.
7. **Financial.** If the financial position of Buyer at any time becomes unsatisfactory to Seller, Seller reserves the right to stop shipments or require satisfactory security or payment in advance. If Buyer fails to make payment or otherwise comply with these Terms or any related agreement, Seller may (without liability and in addition to other remedies) cancel any unshipped portion of Goods sold hereunder and stop any Goods in transit until Buyer pays all amounts, including amounts payable hereunder, whether or not then due, which are owing to it by Buyer. Buyer shall in any event remain liable for all unpaid accounts.
8. **Cancellation: Etc.** Orders are not subject to rescheduling or cancellation unless Buyer indemnifies Seller fully against all costs or expenses arising in connection therewith.
9. **Force Majeure.** Seller shall not be liable for any delay or failure in delivery resulting from causes beyond its control, including earthquakes, fires, floods, strikes or other labor disputes, shortage of labor or materials, accidents to machinery, acts of sabotage, riots, delay in or lack of transportation or the requirements of any government authority.
10. **Shipping: Delivery.** Unless otherwise expressly agreed in writing by Seller:
 - a. Shipments shall be by a carrier selected by Seller;
 - b. Such carrier shall act as the agent of Buyer and delivery to such carrier shall constitute delivery to Buyer;
 - c. All sales and shipments of Goods shall be FOB shipping point (unless otherwise stated in writing by Seller), at which point title to and all risk of loss of the Goods shall pass from Seller to Buyer, provided that Seller shall retain a security interest in the Goods until the full purchase price is paid by Buyer;
 - d. Delivery and shipping dates are estimates only.
 - e. Seller will package Goods as it deems proper for protection against normal handling and extra charges apply to special conditions.
11. **Claims.** Any claim by Buyer against Seller for shortage or damage to the Goods occurring before delivery to the carrier must be presented in writing to Seller within 30 days of receipt of shipment and include the original transportation bill signed by the carrier noting that the carrier received the Goods from Seller in the condition claimed.
12. **Warranties.** (a) Exclusive Warranty. Seller's exclusive warranty is that the Goods will be free from defects in materials and workmanship for a period of twelve months from the date of sale by Seller (or such other period expressed in writing by Seller). Seller disclaims all other warranties, express or implied. (b) Limitations. SELLER MAKES NO WARRANTY OR REPRESENTATION, EXPRESS OR IMPLIED, ABOUT NON-INFRINGEMENT, MERCHANTABILITY OR FITNESS FOR A PARTICULAR PURPOSE OF THE GOODS. BUYER ACKNOWLEDGES THAT IT ALONE HAS DETERMINED THAT THE GOODS WILL SUITABLY MEET THE REQUIREMENTS OF THEIR INTENDED USE. Seller further disclaims all warranties and responsibility of any type for claims or expenses based on infringement by the Goods or otherwise of any intellectual property right. (c) Buyer Remedy. Seller's sole obligation hereunder shall be to replace (in the form originally shipped with Buyer responsible for labor charges for removal or replacement thereof) the non-complying Good or, at Seller's election, to repay or credit Buyer an amount equal to the purchase price of the Good; provided that in no event shall Seller be responsible for warranty, repair, indemnity or any other claims or expenses regarding the Goods unless Seller's analysis confirms that the Goods were properly handled, stored, installed and maintained and not subject to contamination, abuse, misuse or inappropriate modification. Return of any goods by Buyer must be approved in writing by Seller before shipment. Seller shall not be liable for the suitability or unsuitability or the results from the use of Goods in combination with any electrical or electronic components, circuits, system assemblies or any other materials or substances or environments. Any advice, recommendations or information given orally or in writing, are not to be construed as an amendment or addition to the above warranty.
13. **Damage Limits: Etc.** SELLER SHALL NOT BE LIABLE FOR SPECIAL, INDIRECT OR CONSEQUENTIAL DAMAGES, LOSS OF PROFITS OR PRODUCTION OR COMMERCIAL LOSS IN ANY WAY CONNECTED WITH THE GOODS, WHETHER SUCH CLAIM IS BASED IN CONTRACT, WARRANTY, NEGLIGENCE OR STRICT LIABILITY. Further, in no event shall liability of Seller exceed the individual price of the Good on which liability is asserted.
14. **Indemnities.** Buyer shall indemnify and hold harmless Seller, its affiliates and its employees from and against all liabilities, losses, claims, costs and expenses (including attorney's fees and expenses) related to any claim, investigation, litigation or proceeding (whether or not Seller is a party) which arises or is alleged to arise from Buyer's acts or omissions under these Terms or in any way with respect to the Goods. Without limiting the foregoing, Buyer (at its own expense) shall indemnify and hold harmless Seller and defend or settle any action brought against Seller to the extent that it is based on a claim that any Good made to Buyer specifications infringed intellectual property rights of another party.
15. **Property: Confidentiality.** The intellectual property embodied in the Goods is the exclusive property of Seller and its affiliates and Buyer shall not attempt to duplicate it in any way without the written permission of Seller. Notwithstanding any charges to Buyer for engineering or tooling, all engineering and tooling shall remain the exclusive property of Seller. All information and materials supplied by Seller to Buyer relating to the Goods are confidential and proprietary, and Buyer shall limit distribution thereof to its trusted employees and strictly prevent disclosure to any third party.
16. **Miscellaneous.** (a) Waiver. No failure or delay by Seller in exercising any right and no course of dealing between Buyer and Seller shall operate as a waiver of rights by Seller. (b) Assignment. Buyer may not assign its rights hereunder without Seller's written consent. (c) Amendment. These Terms constitute the entire agreement between Buyer and Seller relating to the Goods, and no provision may be changed or waived unless in writing signed by the parties. (d) Severability. If any provision hereof is rendered ineffective or invalid, such provision shall not invalidate any other provision. (e) Setoff. Buyer shall have no right to set off any amounts against the amount owing in respect of this invoice. (f) As used herein, "including" means "including without limitation".

Certain Precautions on Specifications and Use

1. **Suitability of Use.** Seller shall not be responsible for conformity with any standards, codes or regulations which apply to the combination of the Good in the Buyer's application or use of the Good. At Buyer's request, Seller will provide applicable third party certification documents identifying ratings and limitations of use which apply to the Good. This information by itself is not sufficient for a complete determination of the suitability of the Good in combination with the end product, machine, system, or other application or use. The following are some examples of applications for which particular attention must be given. This is not intended to be an exhaustive list of all possible uses of this Good, nor is it intended to imply that the uses listed may be suitable for this Good:
 - (i) Outdoor use, uses involving potential chemical contamination or electrical interference, or conditions or uses not described in this document.
 - (ii) Energy control systems, combustion systems, railroad systems, aviation systems, medical equipment, amusement machines, vehicles, safety equipment, and installations subject to separate industry or government regulations.
 - (iii) Systems, machines and equipment that could present a risk to life or property. Please know and observe all prohibitions of use applicable to this Good.

NEVER USE THE PRODUCT FOR AN APPLICATION INVOLVING SERIOUS RISK TO LIFE OR PROPERTY WITHOUT ENSURING THAT THE SYSTEM AS A WHOLE HAS BEEN DESIGNED TO ADDRESS THE RISKS, AND THAT THE SELLER'S PRODUCT IS PROPERLY RATED AND INSTALLED FOR THE INTENDED USE WITHIN THE OVERALL EQUIPMENT OR SYSTEM.
2. **Programmable Products.** Seller shall not be responsible for the user's programming of a programmable Good, or any consequence thereof.
3. **Performance Data.** Performance data given in this catalog is provided as a guide for the user in determining suitability and does not constitute a warranty. It may represent the result of Seller's test conditions, and the user must correlate it to actual application requirements. Actual performance is subject to the Seller's Warranty and Limitations of Liability.
4. **Change in Specifications.** Product specifications and accessories may be changed at any time based on improvements and other reasons. It is our practice to change part numbers when published ratings or features are changed, or when significant construction changes are made. However, some specifications of the Good may be changed without any notice. When in doubt, special part numbers may be assigned to fix or establish key specifications for your application. Please consult with your Seller's representative at any time to confirm actual specifications of purchased Good.
5. **Errors and Omissions.** The information in this catalog has been carefully checked and is believed to be accurate; however, no responsibility is assumed for clerical, typographical or proofreading errors, or omissions.

Complete "Terms and Conditions of Sale" for product purchase and use are on Omron's website at www.omron.com/oei – under the "About Us" tab, in the Legal Matters section.

ALL DIMENSIONS SHOWN ARE IN MILLIMETERS.

To convert millimeters into inches, multiply by 0.03937. To convert grams into ounces, multiply by 0.03527.



OMRON ELECTRONICS LLC

One Commerce Drive
Schaumburg, IL 60173

847-843-7900

For US technical support or other inquiries:

800-556-6766

OMRON CANADA, INC.

885 Milner Avenue
Toronto, Ontario M1B 5V8

416-286-6465

OMRON ON-LINE

Global - <http://www.omron.com>
USA - <http://www.omron.com/oei>
Canada - <http://www.omron.ca>