

LOC		DIST		REVISIONS			
GP	00	F	LTR	DESCRIPTION	DATE	DMN	APVD
AA2	REVISED PER	ECO-11-004835			11MAR11	RK	HMR

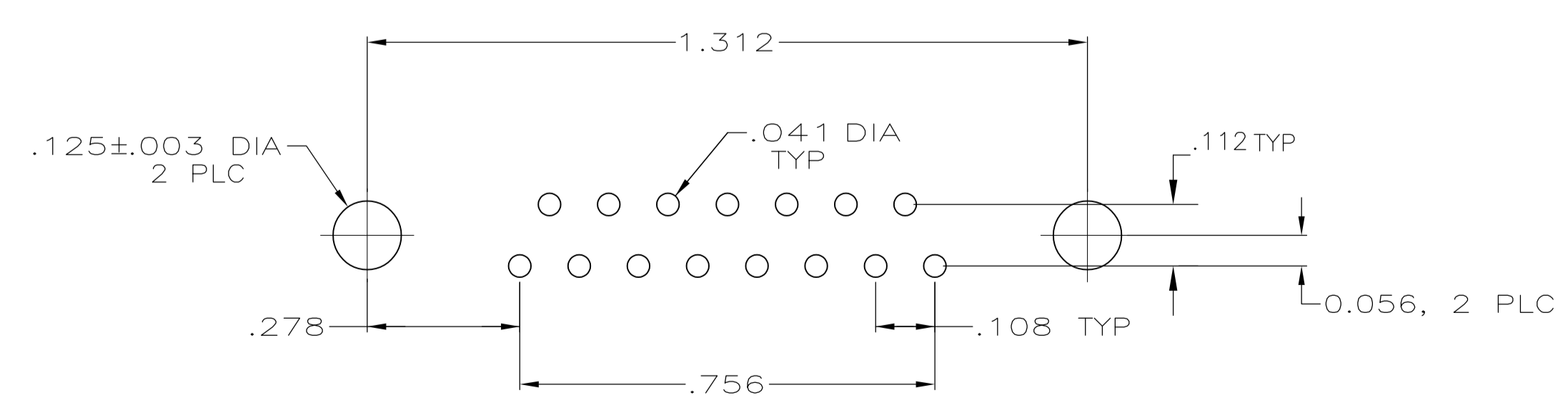
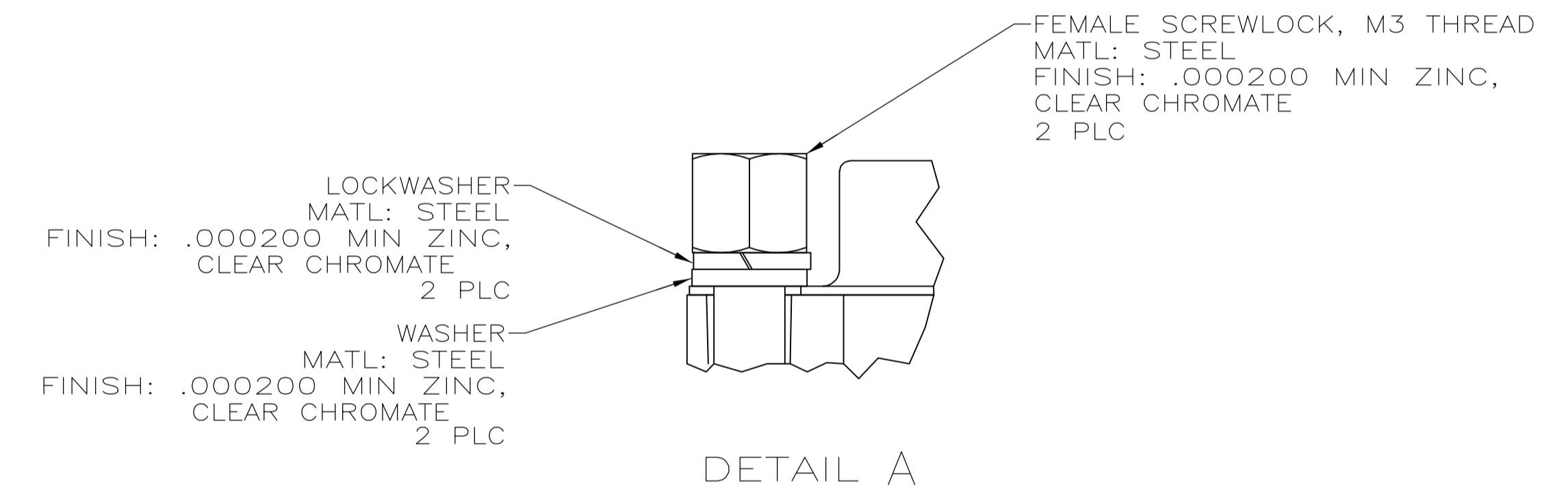
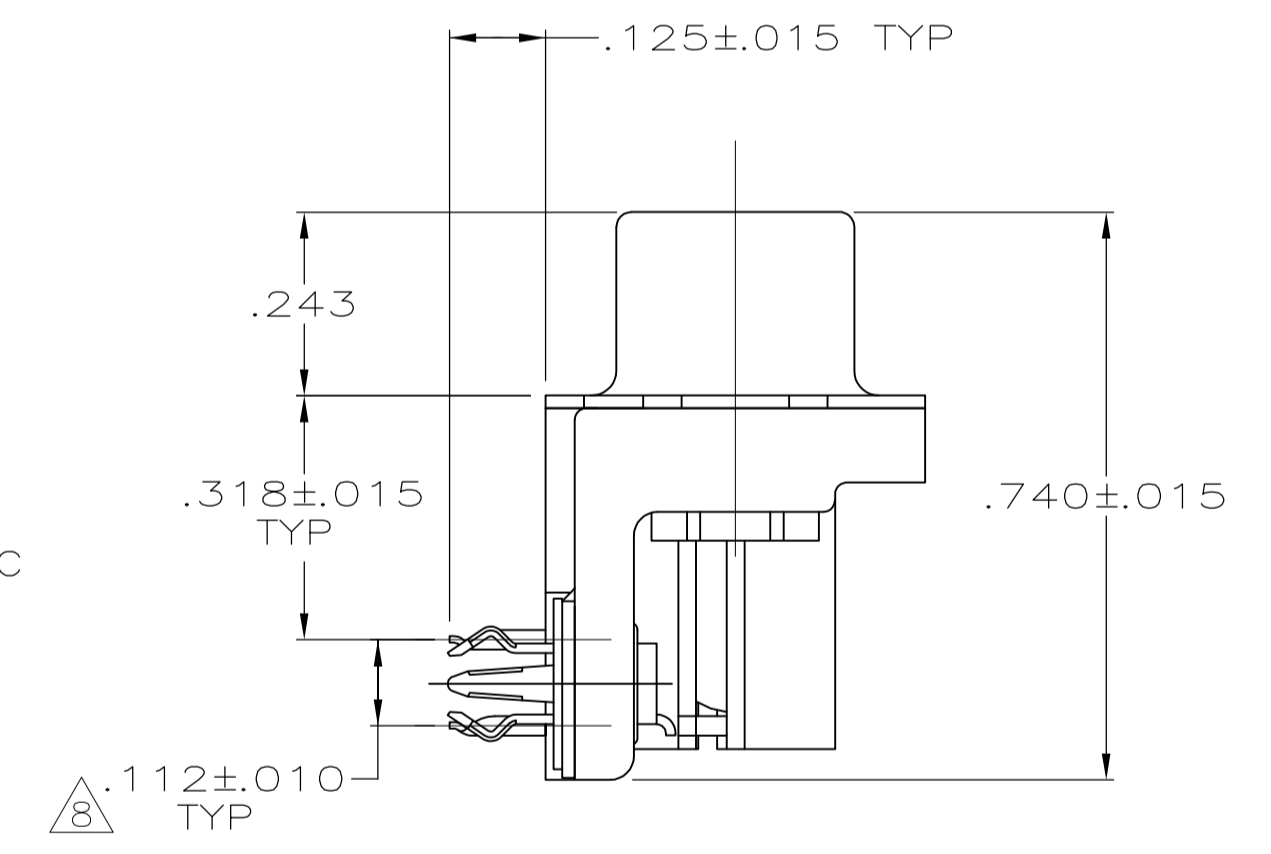
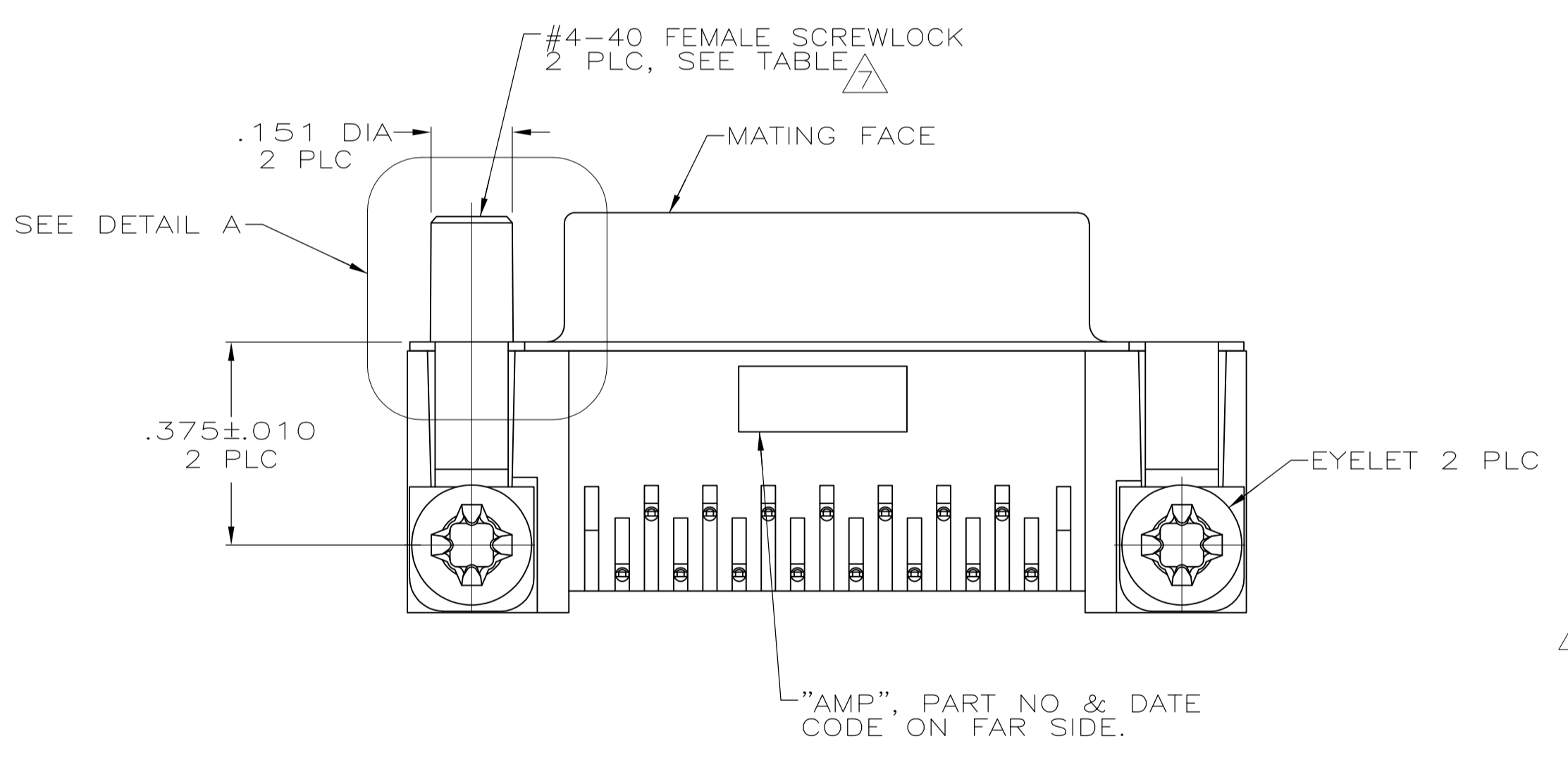
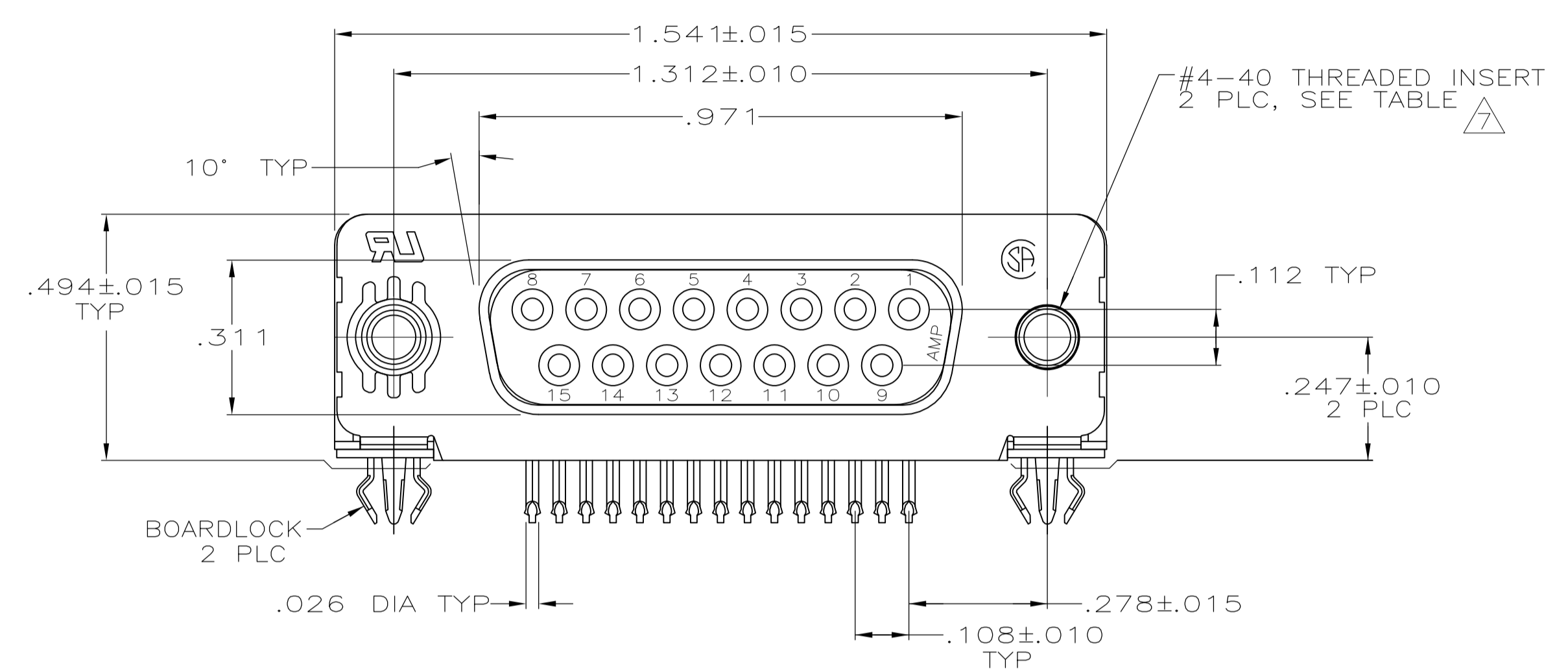

1. CONNECTOR MATES WITH ANY 25 POSN PLUG IN AMPLIMITE™ SERIES.
2. MOLDED PARTS: FLAME RETARDANT 94V-0 RATED THERMOPLASTIC, BLACK.
SHELL: STEEL PER ASTM A109
CONTACTS: PHOSPHOR BRONZE PER QQ-B-750
EYELETS: BRASS
SCREWLOCKS: ZINC
INSERTS: ZINC
BOARDLOCKS: COPPER ALLOY
3. SHELL: .000100 MIN TIN OR TIN-LEAD
CONTACTS: SEE TABLE
EYELETS: TIN
BOARDLOCKS: SEE TABLE
INSERTS AND SCREWLOCKS: CLEAR CHROMATE
4. GOLD PLATING PER MIL-G-45204, NICKEL PLATING PER QQ-N-290, TIN PLATING PER MIL-T-10727.
5. GOLD FLASH FOR A DISTANCE OF .100 MIN FROM MATING END, .000100-.000200 BRIGHT TIN OR BRIGHT TIN-LEAD ON TERMINATION END, ALL OVER .000050 NICKEL ON ENTIRE CONTACT.
6. .000030 GOLD FOR A DISTANCE OF .100 MIN FROM MATING END, .000100-.000200 BRIGHT TIN OR BRIGHT TIN-LEAD ON TERMINATION END, ALL OVER .000050 NICKEL ON ENTIRE CONTACT.
7. SCREWLOCKS & INSERTS WILL WITHSTAND 6 IN-LBS TORQUE & 50 LBS PULL OUT FORCE FROM MATING FACE SIDE.
8. DIMENSION APPLIES FROM CENTER OF CONTACTS.
9. .000030 GOLD FOR A DISTANCE OF .055 MIN FROM MATING END, .000100-.000200 BRIGHT TIN OR BRIGHT TIN-LEAD ON TERMINATION END, ALL OVER .000030 NICKEL ON ENTIRE CONTACT.
10. SPECIAL PACKAGING REQUIRED.
11. OBSOLETE PARTS: OBSOLETE CIS STREAMLINING PER D.RENAUD/D.SINISI

OBSELETE	-	ZINC	FEMALE SCREWLOCKS	TIN	6	6-747845-9
OBSELETE	-	ZINC	FEMALE SCREWLOCKS	TIN	5	6-747845-8
	TRAY	ZINC	THREADED INSERTS	TIN	6	6-747845-7
OBSELETE	TRAY SPECIAL	ZINC	THREADED INSERTS	TIN-LEAD	5	1-747845-2
OBSELETE	TRAY	ZINC	THREADED INSERTS	TIN-LEAD	6	1-747845-4
SUPSD BY 747845-4	TUBE	ZINC	THREADED INSERTS	TIN-LEAD	6	1-747845-0
SUPSD BY 747845-4	-	ZINC	FEMALE SCREWLOCKS,SEE DETAIL A	TIN-LEAD	9	747845-9
OBSELETE	-	ZINC	THREADED INSERTS	TIN-LEAD	6	747845-8
OBSELETE	-	BRASS	ULTRASONIC THREADED INSERTS	TIN-LEAD	5	747845-7
	-	ZINC	FEMALE SCREWLOCKS	TIN-LEAD	6	747845-6
	-	ZINC	FEMALE SCREWLOCKS	TIN-LEAD	5	747845-5
	TRAY	ZINC	THREADED INSERTS	TIN-LEAD	6	747845-4
	-	ZINC	THREADED INSERTS	TIN-LEAD	5	747845-3
OBSELETE	-	-	.125 DIA HOLES	TIN-LEAD	6	747845-2
OBSELETE	-	-	.125 DIA HOLES	TIN-LEAD	5	747845-1

PACKAGING	INSERT MATERIAL	MOUNTING HARDWARE	BOARDLOCK FINISH	CONTACT FINISH	PART NUMBER
				4	

THIS DRAWING IS A CONTROLLED DOCUMENT. DIN 28-JAN-91

J. GALLUCCI/BG 15-APR-91

W.G. LENKER 15-APR-91

J. YOUNG 15-APR-91

RECEPTACLE ASSEMBLY, SIZE 2, 15 POSITION, RIGHT ANGLE, FRONT METAL SHELL, .318 SERIES, .026 DIA POSTS, BOARDLOCKS, AMPLIMITE™ HD-20

108-40025

114-40010

00779C=747845

CUSTOMER DRAWING SCALE 4:1 SHEET 1 OF 1 REV AA2